

# PREDATOR CX3

## IMPORTANT SAFETY INSTRUCTIONS

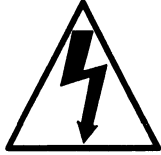

**READ AND UNDERSTAND ALL INSTRUCTIONS  
BEFORE OPERATING OR SERVICING MACHINE**

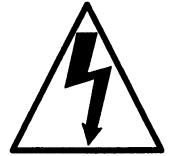

# DANGER!

**Failure to Observe These Instructions Can Cause Personal Injury  
to Machine Operator, By-standers or Possible Machine Damage.**

- **NEVER** attempt to service or perform maintenance functions while machine is plugged into an electrical outlet.
- **ALWAYS** unplug machine before attempting to service the motorized brush attachment.
- **NEVER** operate in standing water. **NEVER** expose to rain. **ALWAYS** store indoors.
- **NEVER** overfill recovery tank or allow water to enter vacuum standpipe. This will cause damage to the vacuum motor and possible electrocution.
- **NEVER** operate machine with a cut, abraded or taped cord.
- **NEVER** operate machine with a broken grounding blade on the plug.
- **ALWAYS** replace the entire cord when the cord or plug is damaged in any manner.
- **NEVER** handle the machine, cord or plug with wet hands.
- **NEVER** drop or insert any object into any machine opening.
- **ALWAYS** keep face, fingers, hair or any other body part, or loose clothing away from any machine opening or any moving part, particularly the revolving brush.
- **NEVER** leave the machine unattended when plugged in. Unplug the machine from the electrical outlet when not in use.
- **ALWAYS** turn the machine off before unplugging it from the electrical outlet.
- **NEVER** operate this machine in the presence of flammable or combustible liquids or fumes.
- When any electrical motor, switch, cord or plug service is required, maintenance should only be done by an authorized service station, an electrician or other qualified persons.
- **NEVER** operate this machine if it is not working properly, if it has been dropped, damaged, exposed to weather, or dropped into water. Return the machine to a service center for examination and repair.
- **NEVER** operate this machine with any air opening blocked. Keep all air openings free of dust, lint, hair, ect.
- **NEVER** operate this machine without solution tank filter screens or vacuum standpipe filter screen in place or if they are clogged. Clean all filter screens after every use.
- **ALWAYS** store this machine indoors. Protect it from rain or snow.
- **NEVER** spray the top of the machine with liquids.
- **DO NOT** pull or carry this machine by the electrical supply cord, use the cord as a handle, close a door on the cord, pull the cord around sharp edges or corners, or expose to heated surfaces.
- **NEVER** disconnect the plug by pulling on the cord. To disconnect the cord from the outlet grasp the plug, not the cord.
- **ALWAYS** unplug this machine before attempting to service.
- **ALWAYS** use a defoamer which will prevent a buildup of foam in the recovery tank. If a defoamer is not used, the motor can be damaged from shampoo being pulled into the vacuum motor.

## SAVE THESE INSTRUCTIONS



# INFORMATION & OPERATING INSTRUCTIONS

**DO NOT OPERATE MACHINE UNTIL YOU HAVE READ THIS SECTION  
IMPROPER USE OF THE PREDATOR CX3 SPOTTER WILL VOID THE WARRANTY**

1. Keep all filters clean. Do not operate machine if filters are clogged.
2. All extension cords must be three wire, and no longer than 50 feet.
3. Do NOT let the pump run dry.
4. Always use defoamer in the recovery tank when foaming occurs to prevent damage to vacuum motor.
5. Always empty the recovery tank when refilling the water tank(s).
6. Keep the machine, tools, and hoses from extremes in temperature. Do not allow the machine, tools or hoses to freeze.

## **INSPECTION:**

Carefully unpack and inspect the PREDATOR CX3 SPOTTER for shipping damage. Each unit is tested and inspected before shipment. Any damage incurred during shipping is the responsibility of the carrier, who must be notified immediately.

## **CLEANING SOLUTIONS:**

We recommend the use of liquid cleaning detergents.-Powdered chemicals may be used, but unless mixed very thoroughly, they could cause a build-up in the pump, the lines, quick couplers, etc. A pH of between 7 and 9 is recommended to avoid premature pump wear. Damage caused by powdered chemicals or by the use of harsh chemicals (very high or very low pH) would void the warranty.

## **MAINTENANCE:**

Prior to each job, inspect the filters in the water tanks. Clean as necessary. Pump damage may occur if filters become clogged or unable to filter debris. Lubricate wheels and latches, as needed. The pump and vacuum motors do not require any maintenance.

The body can be cleaned with a general purpose cleaner and protected with a silicone-based product like Armor All®.

## FEATURES:

### Solution Tanks:

The PREDATOR CX3 SPOTTER has the unique design feature of having two 1-gallon solution tanks. This allows you to have cleaning solution in one tank and clean water for rinsing in the other tank. Simply turn the valve on the machine to switch from one tank to the other. There is no need to empty your detergent tank, clean it, and refill it with water for the rinse cycle.

### Vacuum Tank:

The vacuum tank holds more liquid than the total of both the holding tanks, so you can easily clean an area and rinse it without the need to empty your recovery tank. When you refill your holding tanks, simply remove the vacuum hose from the recovery tank and dump the water out through the vacuum inlet spout.

**Caution:** To prevent damage to the vacuum motor, do not let the water level in the recovery tank exceed 3/4 full. Water temperature must not exceed 60°C (140°F).

**Caution:** When moving the machine with water in any of the tanks, do not tip the machine past a 30 degree angle to avoid spilling water into the vacuum chamber and to avoid damaging the motor.

## SET-UP:

1. Open the latches and remove the recovery tank from the machine.
2. Fill the solution tanks -- one tank will hold your diluted cleaning chemical and the second tank will hold clean water. **NOTE:** Water temperature must not exceed 60°C (140°F).
3. Place the recovery tank back onto the base, and secure the latches. Make sure the screw-in access lid is in place and tight.
4. Attach the vacuum hose to the vacuum inlet on the recovery tank.
5. Connect the solution line to the quick coupling on the rear of the PREDATOR CX3 SPOTTER base.
6. Attach the cleaning tool to the 10' Vacuum Hose/Solution Hose assembly.
7. Turn the knob on the 3-way switch to the desired tank.
8. Turn the rocker switch on. This will start the pump and the vacuum.
9. Press the lever on the tool to begin spraying.

**NOTE:** It may take a few seconds for the solution to reach the spray tip. The tool will automatically suck up the sprayed solution as the tool passes over the wet area.

**NOTE:** When switching from one tank to the other tank, it may take a few seconds of spraying for the solution in the selected tank to reach the spray tip.

10. When finished with the job, disconnect the hoses from the Spotter, remove and empty the recovery tank, then dump the water out of the tanks and clean them.

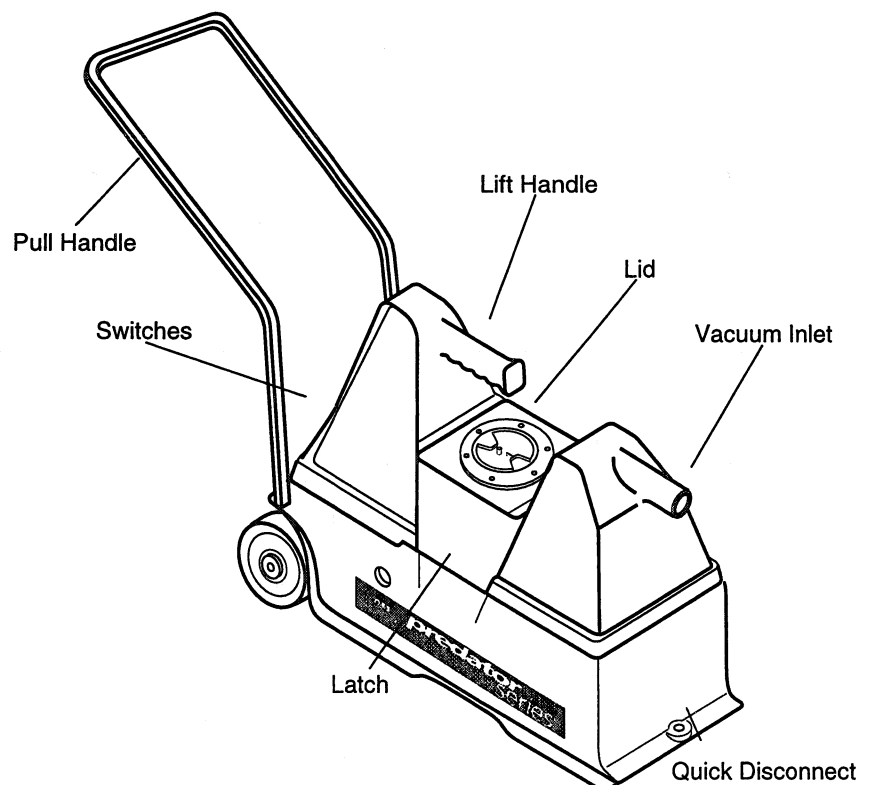

# PREDATOR CX3 SPOTTER PARTS LIST

<u>ITEM #</u>	<u>PART #</u>	<u>DESCRIPTION</u>	<u>ITEM #</u>	<u>PART #</u>	<u>DESCRIPTION</u>
#1	4096261	Base, Holding Tanks	#32	4096061	Hose Clamp
#2	4096131	Plate, Bottom Cover	#33	4091211	Vacuum, 2-Stage, 120V
#3	4090521	#6 X 1/2" Screw, Panhead, S/S		4092101	Vacuum, 2-Stage, 240V
#4	4091251	Latch	#34	4091431	Gasket, Vacuum
#5	4090571	10-32 X 3/8" Screw, Panhead, S/S	#35	4096211	Plate, Vacuum Mount
#6	4096091	Exhaust Flange, Polypropylene	#36	4090591	10-32 X 4", Flathead, S/S
#7	9120671	10-32 X 5/8" Screw, Flathead	#37	9120660	10-32 X 5/8" Screw, Flathead
#8	9120660	10-32 Hex Nut, w/Ny-Lok	#38	4090580	10-32 Hex Nut, w/Ny-Lok
#9	4096141	Axle, 1/2" X 11-1/4"	#39	4096081	Spacer, Nylon, 1"
#10	4096251	Wheel, 5", nonmarking	#40	4090711	10-32 Hex Nut
#11	4091021	Axle Cap	#41	9120660	10-32 Hex Nut, w/Ny-Lok
#12	0291411	10-24 Acorn Nut, Nickel Plated	#42	4090581	10-32 X 5/8", Button Head
#13	9120671	10-32 X 5/8" Screw, Flathead	#43	4096161	Pump, 55 PSI, 120V
#14	4096231	Cap, Plastic		4096301	Pump, 55 PSI, 240V
#15	4096201	Handle Bracket Set, Left Side	#43A	4096171	Bracket, Pump
#15A	4096191	Handle Bracket Set, Right Side	#44	4096281	Filter, 40 Mesh, 1/4 p.t., S/S
#16	4096201	Handle Bracket Set, Left Side	#45	4095011	Bushing, Brass, 1/4 pt X 1/8 pt
#16A	4096191	Handle Bracket Set, Right Side	#46	4091261	Latch Strike
#17	N/A	Perm Nut, (part of bracket)	#47	4090581	10/32 X 5/8 Screw, Socket Button Head
#18	9120880	1/4 Split Lock Washer	#48	9120660	10-32 Hex Nut, w/Ny-Lok
#19	4090641	1-1/4-20 X 3-1/2" Hex Shoulder Bolt	#49	4096271	Vacuum/Recovery Tank
#20	4096071	Plug, 3/4" square, Heavy Duty	#50	4096121	Lid, Access, Vacuum Tank
#21	4096181	Handle, Black Powder Coated	#51	4090561	8-32 X 7/8 Screw, Flathead, S/S
#22	4090041	Switch Plate (empty), CX3	#52	4080551	8-32 Hex Nut, w/Ny-Lok, S/S
#23	N/A	Nut, Brass, Part of Valve	#53	4096121	Lid, Access
#24	4091041	Switch, SPST, Covered w/Light	#54	4096101	Gasket
#25	4090501	#4 x 1/4 Screw, Panhead, S/S	#55	4096031	Quick Disconnect, Male, 1/8 p.t.
#26	4096021	Cord Retainer, Water Tight	#57	4096041	Nipple, Brass, 1/8 p.t.
#27	4090681	1/2" Hex Nut, Plastic, .75ID X 1" OD	#58	4096011	Elbow, Brass, 1/4 p.t., 90 degree
#28	4096151	Valve, Three - Way	#59	4096111	Gasket
#29	4091091	Elbow, Brass, 1/8 p.t., 90 degree			
#29A	4096241	Elbow & Hose Barb, 1/8 pt - 1/4 hose			<b><u>NOT SHOWN</u></b>
#30	4096051	Hose Barb, Brass, 1/4 hose x 1/8 p.t.	4096321		Power Cord, 120V
#30A	4090661	Washer, Rubber, 60 D Buna N	4096331		Power Cord, 240V
#31	4096221	Hose, 1/4 ID, Braided			

# PREDATOR CX3 SPOTTER

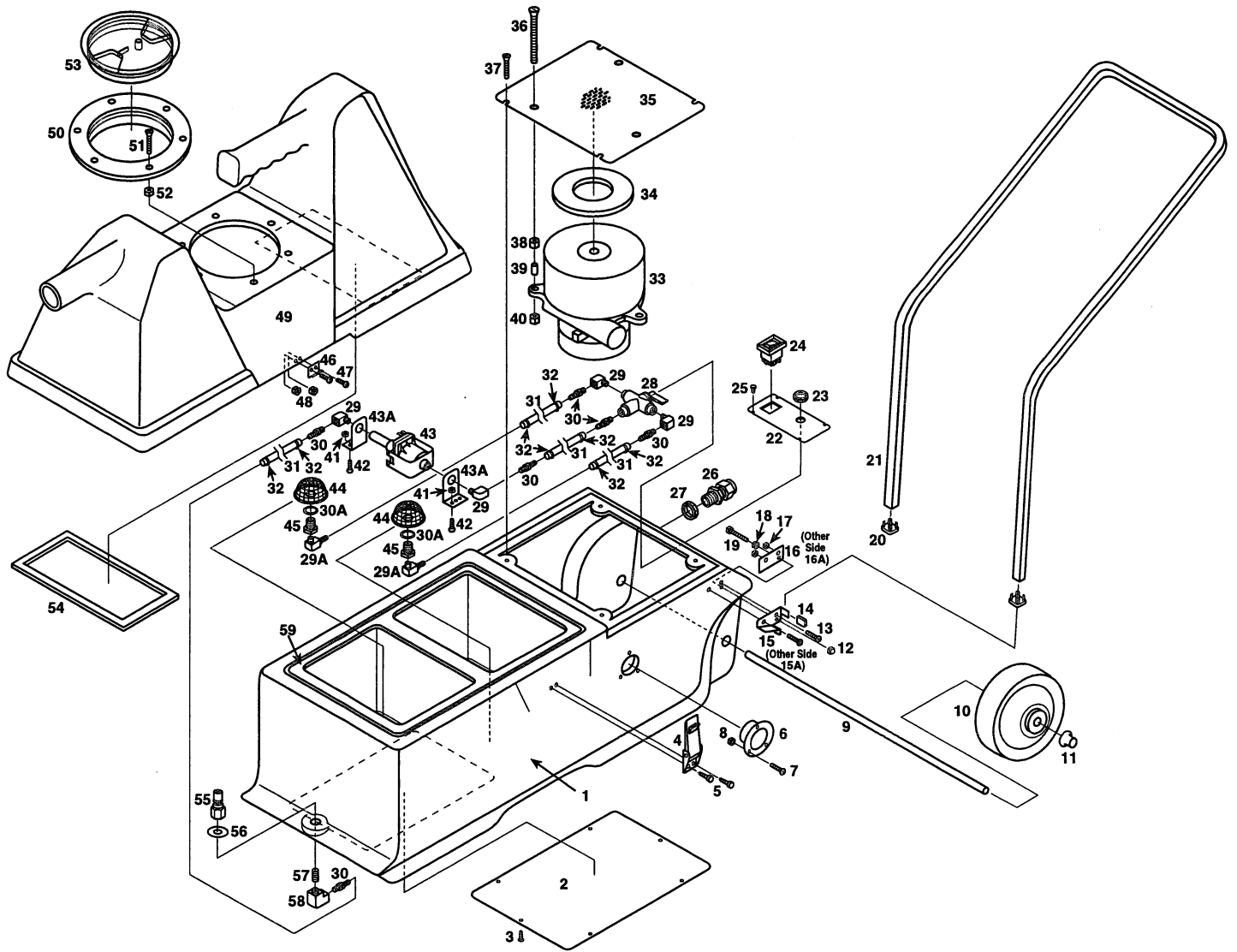

# COMMON STAINS AND CLEANING TREATMENTS

## TREATMENT METHODS

- First:** Remove excess material by blotting to absorb liquids, or by scraping with a dull edge (butter knife) if a solid.
- Second:** Clean the remaining stain as directed by the chart below. Always follow the direction on the container. Apply the cleaning material directly to the stain (avoid over wetting the carpet or upholstery), then remove the loosened stain material with a white absorbent cloth or tissue.
- Third:** When the carpet is dry, gently brush the carpet pile to restore its appearance.
- Note:** Treat unknown stains with a volatile solvent first and follow with other agents as required. If you are uncertain of the effect of the cleaning agent on the carpet fiber or dye, test on an inconspicuous area first.

<u>STAIN TYPE</u>	<u>TREATMENT MATERIAL</u>
Asphalt	Volatile solvent/detergent
Beer	Liquid detergent, White vinegar
Berry stain	Liquid detergent, Ammonia 3-6%, Water
Bleach	Liquid detergent, Water
Blood (dried)	Warm detergent, Ammonia 3-6%, Water
Blood (wet)	Liquid detergent, Water
Butter	Volatile solvent
Catsup or Mustard	Liquid detergent
Chewing gum	Volatile solvent
Chocolate	Liquid detergent, Ammonia water
Coffee	Detergent, White vinegar, Volatile solvent
Cola drink	Liquid detergent
Creme de Menthe (green)	Liquid detergent
Egg (raw)	Liquid detergent
Food dye	Liquid detergent, Water
Furniture dye or polish	Paint/Oil/Grease remover, Detergent
Gravy	Liquid detergent
Lipstick	Paint/Oil/Grease remover
Mascara	Paint remover, Volatile solvent, Detergent, Water
Milk	Liquid detergent
Orange drink	Liquid detergent, Water
Shoe polish	Heated iron into clean towel, Volatile solvent
Tea	Liquid detergent
Tomato Juice	Liquid detergent
Urine	Liquid detergent, Water
Vomit	Warm detergent, Water, White vinegar
Wine	Liquid detergent, Ammonia 3-6%, Water, Vinegar

# PREDATOR CX3 SPOTTER WIRING DIAGRAM All Voltages

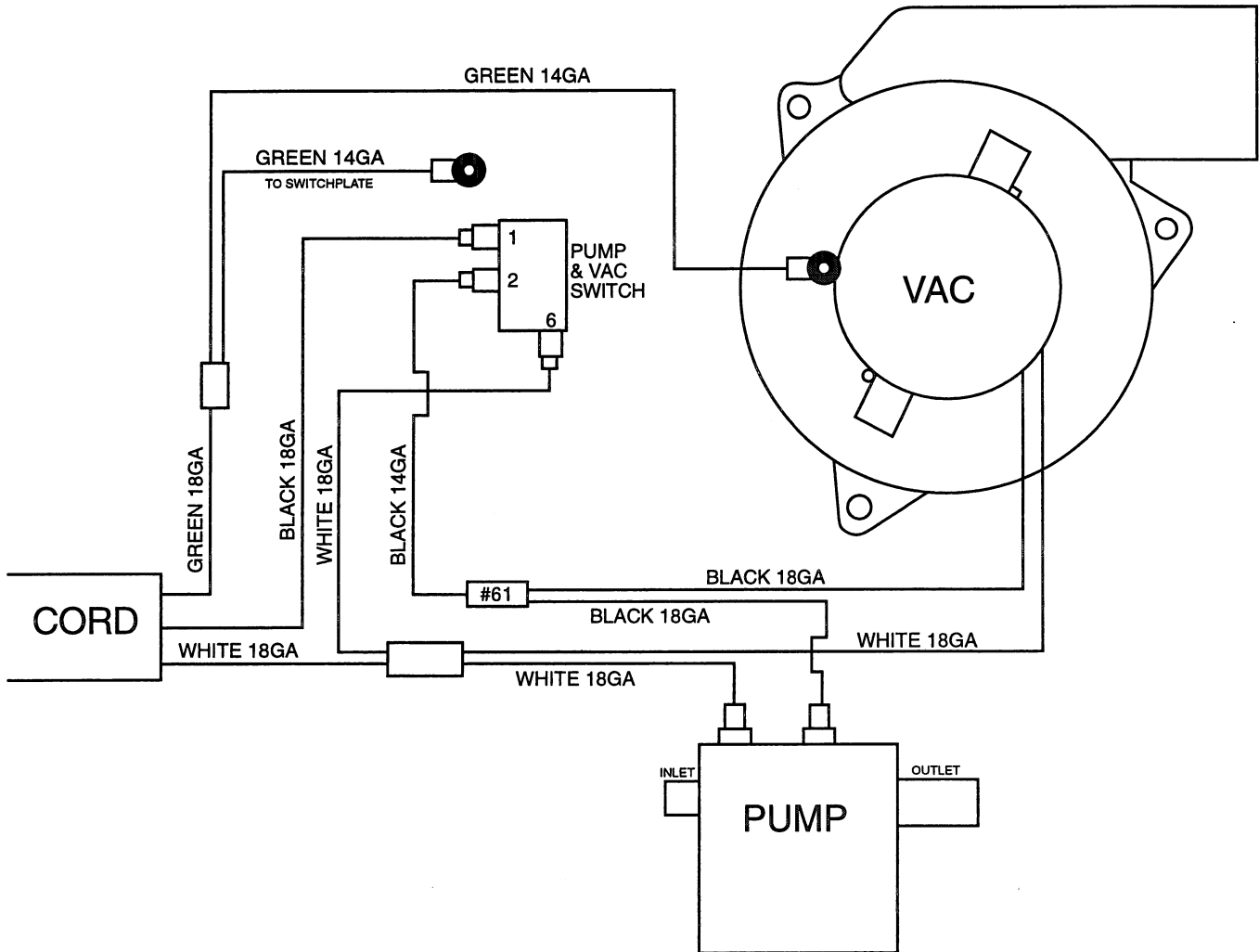



## **NSS Enterprises, Inc.**

3115 Frenchmens Road, Toledo, Ohio 43607  
PHONE (419) 531-3761 • FAX (419) 531-3761

### **NSS® Enterprises, Inc. European Distribution Centre**

™ Unit II, Pinfold Trading Estate 55 Nottingham Road  
STAPLEFORD, NOTTINGHAM NG9 8AD ENGLAND U.K.  
PHONE: (44) 0115 939 1568 FAX: (44) 0115 949 0615