

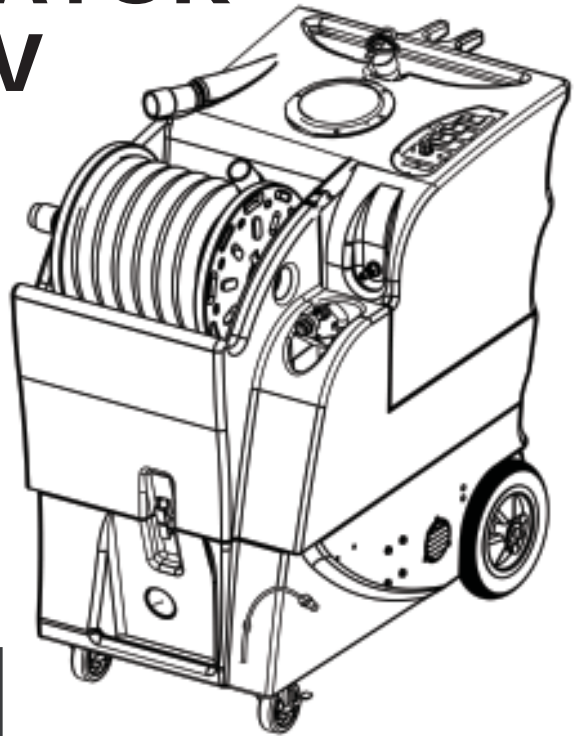

TERMINATOR 120V

INFORMATION & OPERATING INSTRUCTIONS



CAUTION: DO NOT OPERATE MACHINE UNTIL YOU HAVE READ ALL SECTIONS OF THIS INSTRUCTION MANUAL

IMPROPER USE OF THE MACHINE WILL VOID THE WARRANTY

1. Always use a defoamer when foaming occurs to prevent vacuum motor damage.
2. Before each use, remove the spray tool from the hose, and check to make sure the spray nozzles are securely tightened to the spray tool. A loose nozzle could fly off during use.
3. Keep machine from rain and snow, extremes in temperatures, and store in a heated location. Use the machine indoors. Do not use outdoors.
4. Never allow the spray to remain fixed in one spot.
5. Use approved chemicals only. NO SOLVENTS.
6. Never use this machine to strip finish from floors.
7. Never use water above 130° F/54° C in the solution tank.
8. Always use your pre-filter bag and keep both it and all other filters clean.

IMPORTANT SAFETY INSTRUCTIONS

This machine is only suitable for commercial use, for example in hotels, schools, hospitals, factories, shops and offices other than normal residential housekeeping purposes.

When using any electrical appliance, basic precautions should always be followed, including the following:

NOTE: Read all instructions before using this machine.



WARNING!

To reduce the risk of fire, electric shock, or injury:

- Do not leave the machine unattended when it is plugged in. Unplug the unit from the outlet when not in use and before servicing.
- To avoid electric shock, do not expose to rain or snow. Store, and use, indoors.
- Do not allow to be used as a toy. Close attention is necessary when used near children.
- Use only as described in this manual. Use only the manufacturer's recommended attachments.
- Never add water over 130° F/54° C to the solution tank.
- Do not use with damaged cord or plug. If the machine is not working as it should, has been dropped, damaged, left outdoors or dropped into water, return it to a service center.
- Protect the cord. Do not: use the cord as a handle, close a door on the cord, or pull the cord around sharp edges or corners. Do not run the machine over the cord. Keep the cord away from heated surfaces. To unplug, grasp the plug, not the cord.
- Do not handle the plug, the cord or the machine with wet hands.
- Extension cords must be 12/3 and no longer than 50 feet. Replace the cord or unplug immediately if the ground prong becomes damaged.
- Do not put any object into openings. Do not use with any opening blocked; keep free of dust, lint, hair, and anything that may reduce air flow.
- Keep loose clothing, hair, fingers, and all parts of body away from openings and moving parts.
- Do not pick up anything that is burning or smoking, such as cigarettes, matches, or hot ashes, or any health endangering dusts. Do not use to pick up flammable or combustible liquids such as gasoline or use in areas where they may be present.
- Turn off all controls before unplugging.
- Use extra care when cleaning on stairs.
- Connect to a properly grounded outlet only.
- Liquid ejected at the spray nozzle could be dangerous as a result of its temperature, pressure, or chemical content.

SAVE THESE INSTRUCTIONS

INSPECTION:

Carefully unpack and inspect your TERMINATOR for shipping damage. Each machine is tested and inspected before shipping. Any shipping damage incurred is the responsibility of the carrier. You should notify the carrier immediately if you notice damage to the box or to the machine or parts.

CLEANING SOLUTIONS:

Select a proper pre-spray for the surface to be cleaned, and apply the pre-spray. Use a neutral pH rinse or detergent (6 to 10 pH) in the King Cobra to prevent premature wear of the pumps, seals, and other components. Damage caused by the use of improper or harsh chemicals is not covered by warranty. Powders are not recommended.

MAINTENANCE:

For optimum performance, flush the machine with clear water at the end of each working day. Always use the pre-filter bag and keep it and both pump inlet filters clean. Once a month, minimum, run a flushing compound through the machine to break up any mineral or chemical build-up that may have formed. The vacuum motor, pump motors, and the pumps do not require any scheduled maintenance; however, the motors may require replacement brushes after 1000 - 1500 hours, and the high pressure pump and unloader valve may require rebuild kits after 500 -1000 hours (refer to machine part list for numbers). Clean the body with an all purpose detergent, and protect it with an automobile interior polish. Lubricate the wheels, castors, and quick disconnects with an all purpose silicone spray.

Record the serial number and model of your new extractor here:

(and be sure to register your purchase to activate your warranty)

Serial Number: _____ **Model:** TERMINATOR

Purchase Date: _____

Write the name and phone number of your distributor:

SAVE THESE INSTRUCTIONS

KNOW YOUR MACHINE

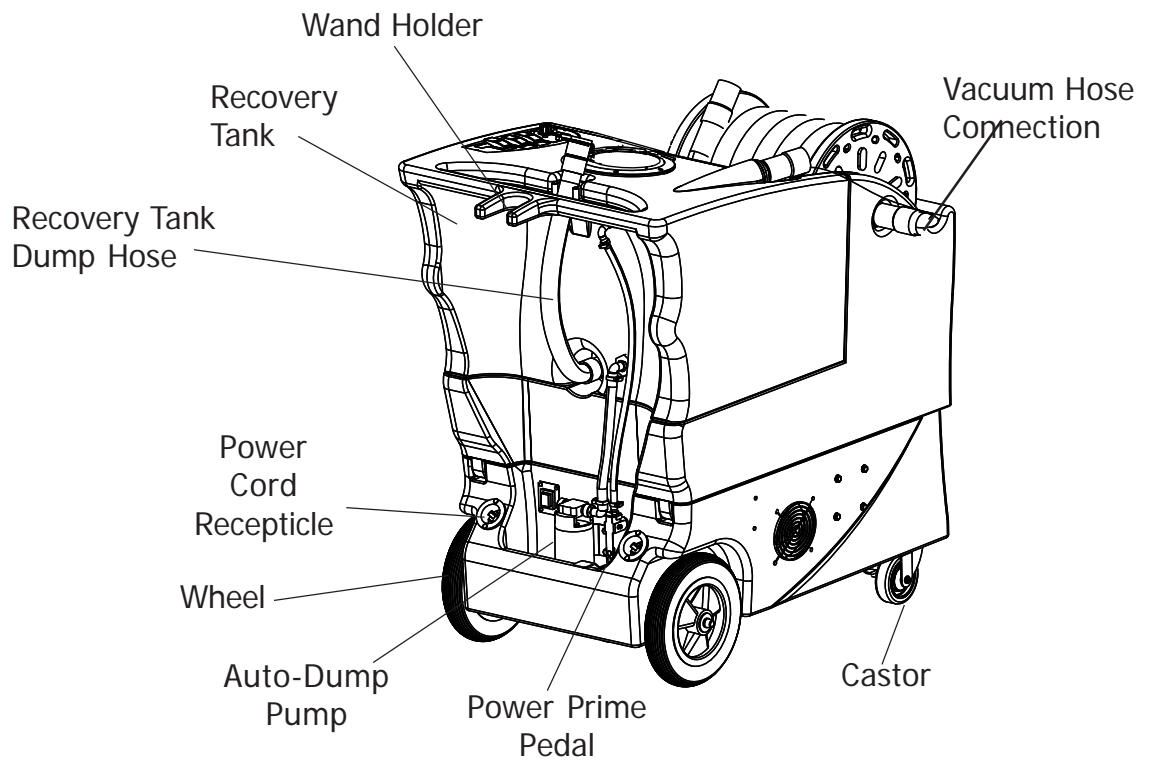
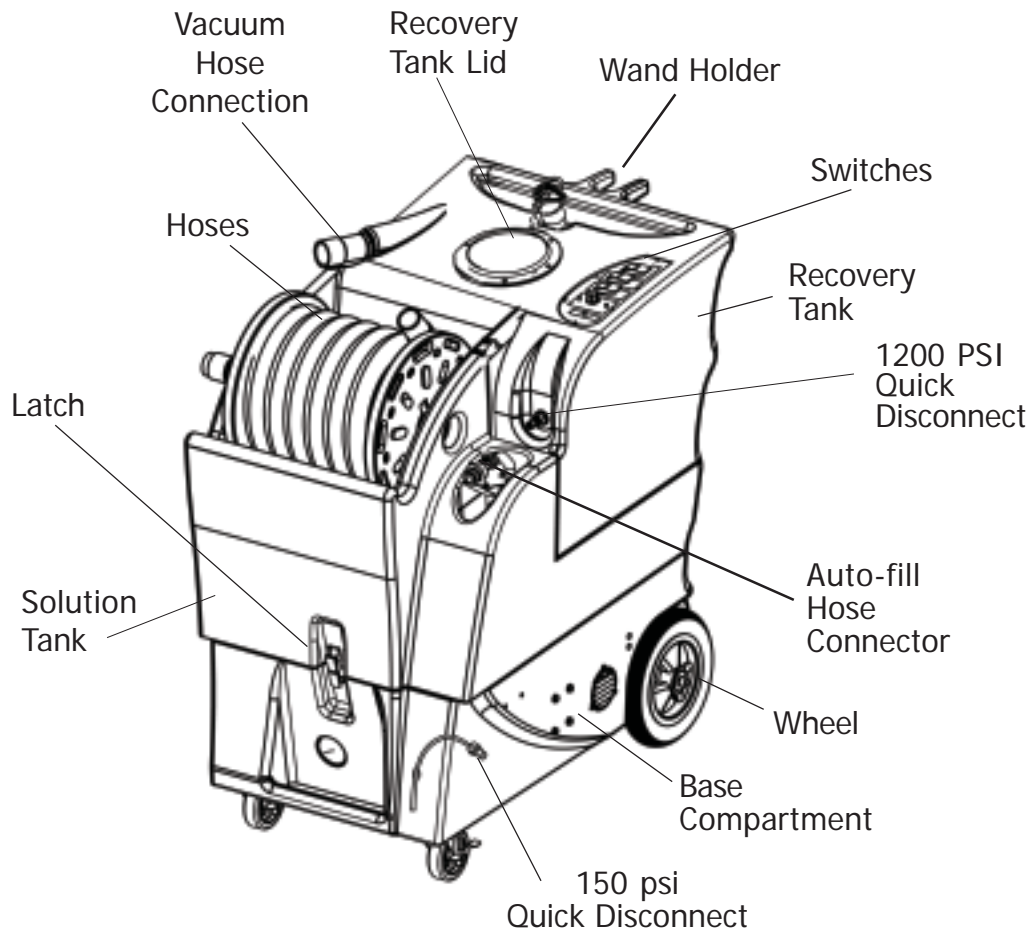

SWITCH PLATE

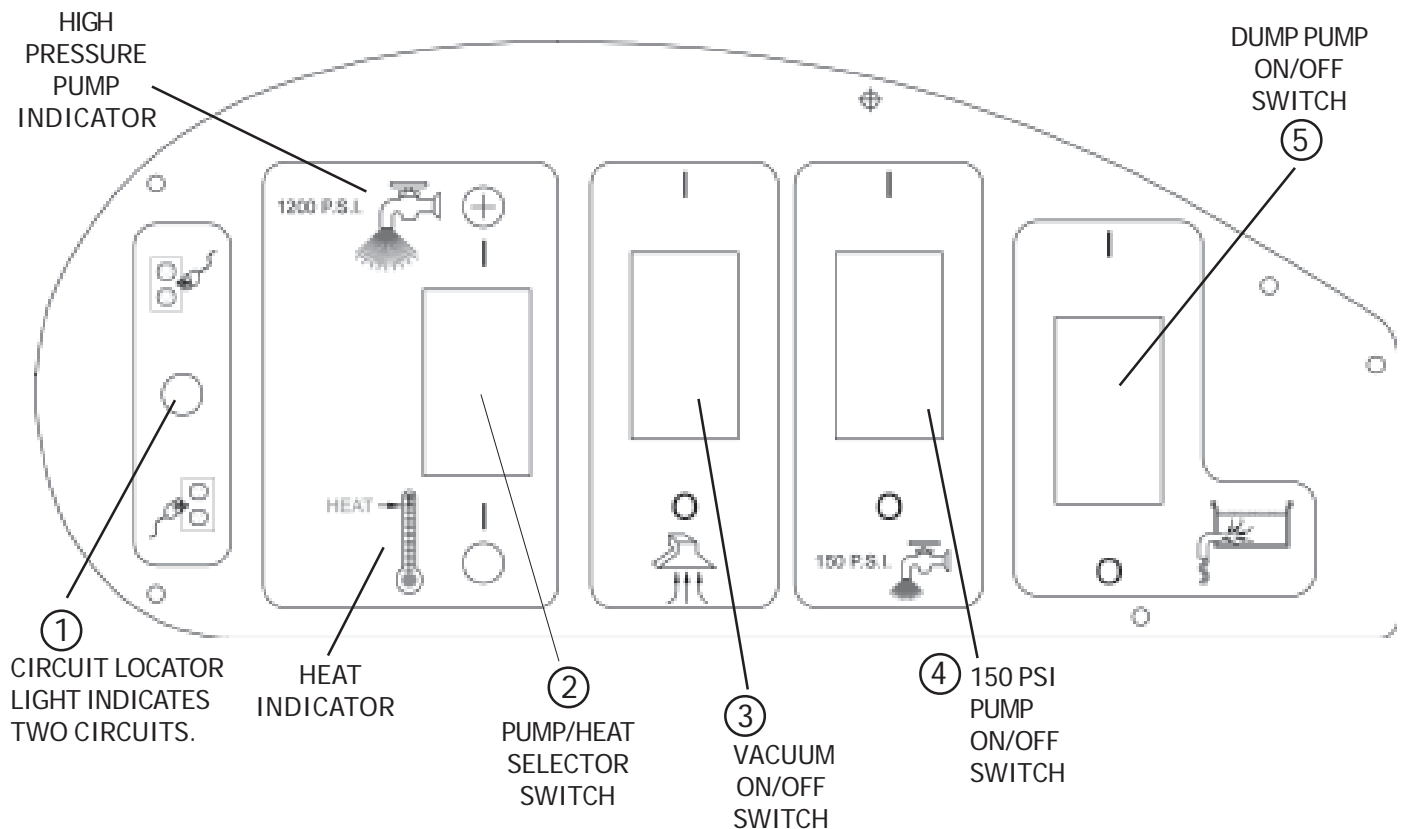

- 1) This light will turn on to indicate the your two power cords are plugged into two circuits. If this light does not turn on, keep trying outlets with one of the cords until you get the green light to turn on. Running the machine with out a green light may cause a circuit breaker in the wall to trip.
- 2) This selector switch determines whether you will use the 1200 psi pump or the heater. You can select either, but not both. The heater will only work with the 150 psi pump. The center positon is OFF, and neither the high pressure pump or the heater is turned on.
- 3) This switch turns the vacuum motor ON and OFF.
- 4) This switch turns on the low pressure pump for cleaning upholstery or carpet. Turn the selector switch (#2) to heat if you want to clean with hot water.
- 5) This switch turns on the automatic pump-out.

SET-UP AND OPERATION

LOW PRESSURE

1. Before each use, inspect the machine, hoses, and cleaning tools for cleanliness and completeness. Make sure filters and the pre-filter bag are installed and are clean.
Make sure hoses are in good condition and the spray nozzle(s) is tight.

REFER TO THE AUTO-FILL AND AUTO-DUMP INSTRUCTIONS ON THE FOLLOWING PAGES

2. If you choose to use the auto-dump, connect the dump hose to brass hose fitting on the back of the machine, and place the open end of the hose in a drain. Otherwise, just make sure the brass cap is on thehose connector. Make sure the recovery tank drain hose is closed, and the lid is tight on the recovery tank.
3. If you choose to use the auto-fill feature, connect the fill hose to the auto-fill connector (located over the

LOW PRESSURE continued

solution tank fill hole). Turn on the water source, and allow the tank to fill with water. When using the auto-fill system, the auto-fill float will automatically turn on and turn off as the tank empties and then fills.

NOTE: If you are not going to use the auto-fill system, just **fill** the tank with water and cleaning chemical. Follow chemical directions regarding dilution and mixing. Do not use harsh chemicals; they may damage seals in pumps and valves, and cause the pump to wear prematurely.

NOTE: Never use water with a temperature exceeding 130 °F / 54 °C.

4. Use a pump-up sprayer to pre-spray the area to be cleaned while the tank is filling. Follow chemical directions.
5. Connect the solution hose (from the reel) to the low PSI quick disconnect on the front of the base of the machine. Connect the vacuum hose from the center of the reel to the hose barb on the recovery tank. Connect the vacuum hose on the reel to your cleaning tool.
6. Plug in the two power cords on separate circuits. Do not connect both cords to the same outlet. The green, 'separate circuit' locator light (1) on the switch plate should light up. If the locator light does not come on, check the circuit breaker box in the wall, and/or try different outlets until it does turn on. Although all systems in the machine may work correctly if you are not on two circuits, a circuit breaker in a wall panel may trip. If you make sure the green light is turned on, you will prevent tripped circuit breakers.
7. Turn on the heat by placing the HIGH PRESSURE/HEAT selection switch (2) in the DOWN position.
NOTE: The high pressure pump and the heat can not operate at the same time. **NOTE:** this switch is off when it is set to the middle position and neither the heat or the high pressure pump is selected.
8. Turn on the 150 PSI "demand" pump (4). **NOTE:** the 'demand' pump will not run until pressure is released.
9. Spray for a few seconds to fill the lines with solution. Wait two minutes to allow the heater to reach temperature.
10. Begin cleaning. It may take several cycles to heat the lines and the cleaning tool.
11. If you are not using the autofill and autodump features, turn off the pump and vacuum when the solution tank gets low, fill the solution tank, and empty and clean the recovery tank.
12. When finished with the job, turn off the water source. Vacuum the remaining solution from the holding tank into the recovery tank. Run a few gallons of clean water through the system. Drain the recovery tank by placing the drain hose over a drain or into a bucket and removing the cap. When the tank is empty, cap the drain hose and place it back in the velcro holder.
13. Use defoamer to prevent foam, which could result in damage to your vacuum motor.

HIGH PRESSURE WASHER

1. Before each use, inspect the machine, hoses, and cleaning tools for cleanliness and completeness. Make sure filters and the pre-filter bag are installed and are clean.

Make sure hoses are in good condition and the spray nozzle(s) is tight.

REFER TO THE AUTO-FILL AND AUTO-DUMP INSTRUCTIONS ON THE FOLLOWING PAGES

2. If you choose to use the auto-dump, connect the dump hose to brass hose fitting on the back of the machine, and place the open end of the hose in a drain. Make sure the recovery tank drain hose is closed, and the lid is tight on the recovery tank. Otherwise, just make sure the brass cap is on the hose connector.
3. If you choose to use the auto-fill feature, connect the fill hose to the auto-fill connector (located over the solution tank fill hole). Turn on the water source, and allow the tank to fill with water. When using the auto-fill system, the auto-fill float will automatically turn on and turn off as the tank empties and then fills.
NOTE: If you are not going to use the auto-fill system, just **fill** the tank with water and cleaning chemical. Follow chemical directions regarding dilution and mixing. Do not use harsh chemicals; they may

HIGH PRESSURE continued

damage seals in pumps and valves, and cause the pump to wear prematurely.

NOTE: Never use water with a temperature exceeding 130 ° F / 54 °C.

4. Pre-spray the area to be cleaned, with a pump-up sprayer, while the tank is filling. Follow chemical directions.
5. Connect the solution hose (from the reel) to the 1200 PSI Quick Disconnect on the front of the tank, below the switch plate.
6. Plug in the two power cords. Do not connect both cords to the same outlet. The green, 'separate circuit locator light (1) on the switch plate should light up. If the locator light does not come on, check the circuit breaker box in the wall, and/or try different outlets until it does turn on. Although all systems in the machine may work correctly if you are not on two circuits, a circuit breaker in a wall panel may trip. If you make sure the green light is turned on, you will prevent tripped circuit breakers. Turn on the high pressure pump by placing the HIGH PRESSURE/HEAT selection switch (2) in the UP position, to select the High Pressure Pump. **NOTE:** The high pressure pump and the heat can not operate at the same time. **NOTE:** this switch is off when it is set to the middle position and neither the high pressure pump or the heater is selected.
8. Prime the 1200 psi pump using the '**power prime**' system: turn on both the pump and the vacuum, cover the hole in the hose barb with your hand, then depress the Power Prime Pedal. This will pull trapped air through the pump and into the recovery tank, priming the pump. You will notice a 'tone' change from the pump (smoother, with less of a rattle), and the water being pulled into the recovery tank will change to a clear, solid stream. Priming may take 20 - 60 seconds and will require a full solution tank. When the pump is primed, release the Power Prime Pedal, and turn off the pump and the vacuum. Depress the Power Prime Pedal once again, for a moment, to release the line pressure. Proceed to the next step.
9. Use defoamer to prevent foam, which could result in damage to your vacuum motor.

NOTE: Always use the pre-filter bag and keep all filters clean.
Never use the Terminator to strip finish from floors.



CAUTION: Use care when handling hazardous chemicals.

CAUTION: Never leave the 1200 psi pump running when you are not actively using it.

DANGER: Do NOT use solvents, or any chemicals that may be flammable, explosive

SPECIFICATIONS:

Rotomolded Body:	Lifetime Warranty
Vacuum:	7.2" 3-stage
VAC Shutoff:	Ball & Float
Pump:	Positive displacement 1200 psi carpet
Waterlift:	140"
Heat:	Instant to 212 °F
Heater:	2000 Watts
Wand:	Stainless steel, single bend, twin tip
Weight:	170 lbs.
Dimensions:	39"H x 21"W x 36" L

AUTO-FILL

Operation:

- Attach a 3/4" garden hose to the autofill valve, and connect the other end of the hose to your water source.
- Make sure the float that hangs from the autofill valve into the tank is free of obstruction and can move freely.
- Turn the water supply on.
- The autofill float will automatically shut-off the flow of incoming water when the solution tank is nearly full, and it will allow the valve to open again once the water level has dropped to a predetermined level.

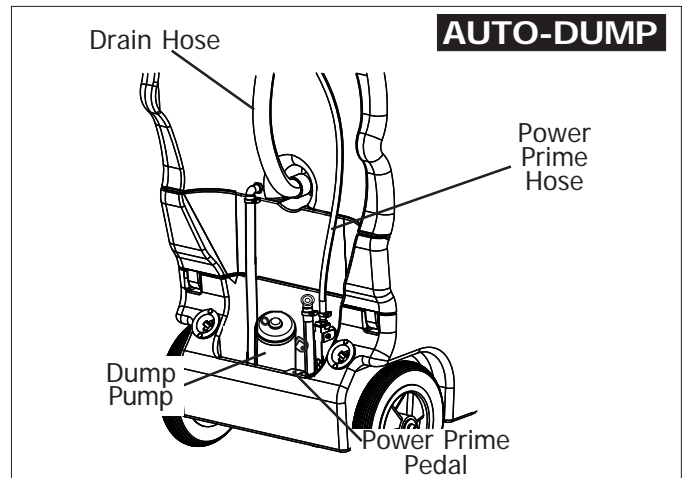
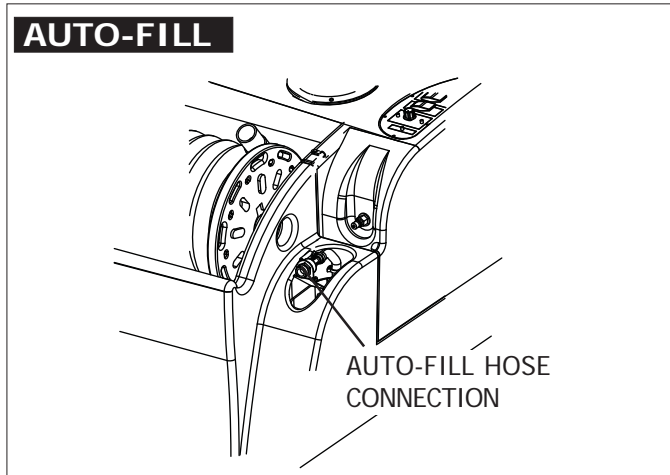

AUTO-DUMP

Operation:

- **Before each use:** if necessary, unscrew the stainless steel filter at the bottom of the recovery tank and clean it. Also make sure the float in the recovery tank is clean.
- Attach a 3/4" garden hose to the dump pump outlet fitting on the back of the base of the machine.
- Refer to illustration below
- Run the other end of the hose into a drain.
- Turn ON the dump pump switch (switch is located on the switch panel on the top of the machine).
- **NOTE:** the dump pump is 'self-priming.' You should see water start to flow within 30 seconds of the pump turning on. If the water level in the tank is high enough to activate the float switch. If water does not begin to flow, check the filter to see if it is plugged with debris.
- **After each job:** run clear water through the dump pump to wash out any chemical residue. Remove and clean the stainless steel filter in the back of the tank. Reinstall the filter once it is clean. Clean and empty the recovery tank.



DANGER: DO NOT USE SOLVENTS, OR ANY CHEMICALS THAT MAY BE FLAMMABLE, EXPLOSIVE OR COMBUSTIBLE.

CAUTION: always use a defoamer in the recovery tank to prevent water or foam from entering the vacuum motor.



DANGER: always unplug the machine from the electrical outlet(s) before cleaning or maintaining. Certain internal components are electrically live, even with switches in their OFF position.

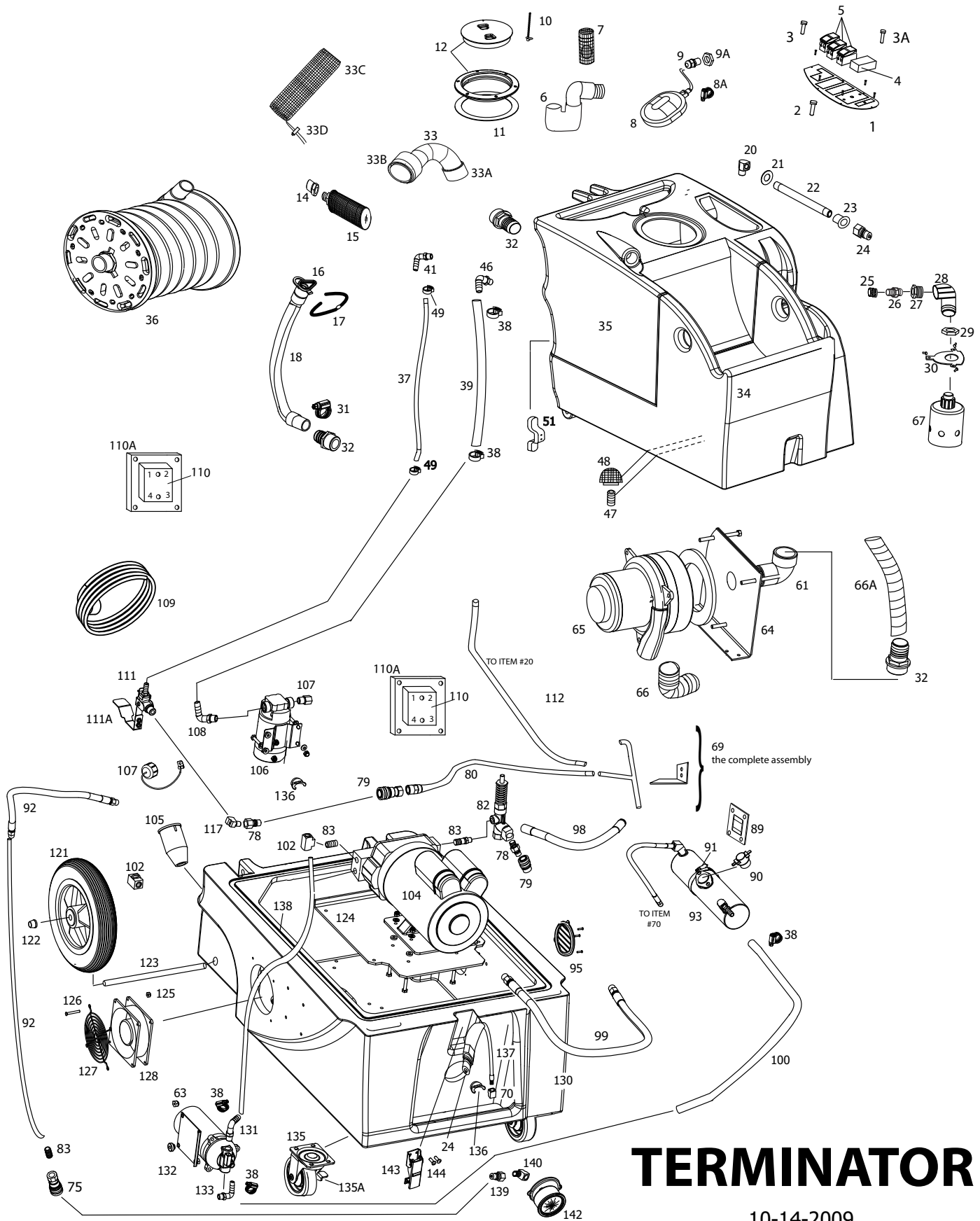

TERMINATOR

10-14-2009

TERMINATOR

PART LIST 120V

<u>ITEM</u>	<u>PART No.</u>	<u>DESCRIPTION</u>	<u>ITEM</u>	<u>PART No.</u>	<u>DESCRIPTION</u>
1	1303	Switch Plate	67	1310A	Float, Auto-fill, high temp.
2	78	Light, green, 120V	69	1530	"T" hose assembly, complete
3	78B	Light, red, 120V	75	220	Quick disconnect, female
3A	227	Light, green, 230V	78	219	Quick Disconnect, male, open
4	56220001	Switch, selector, ON/OFF/ON	79	220	Quick Disconnect, female, open
5	FP345	Switch, ON/OFF, with actuator	80	1530	Hose, power prime inlet, 30"
6	FP364	Ball float & manifold assembly	82	1163	Valve, pressure regulator
7	929B	Ball float	83	92A	Nipple, S/S, 1/4 mpt
8	2068	Float, Auto-Dump	89	455	Bracket, heater mount
8A	1518	Hose clamp	90	FP256	Heat repair kit
9	230	Cord retainer, water tight	91	76A	Hose Clamp, 2-3/4"
10	805	Chain, lid retaining	92	FP420	Hose, Pump to Gauge, complete
11	1074	Gasket, recovery lid	93	FP371	Heat Exchanger, complete
12	2086A	Lid, and ring, 6"	95	928	Louver, 3", includes screws
14	937	Bushing, PCV	98	1530A	Hose, from unloader, 33"
15	2069B	Filter, Auto-dump	99	1162	Hose Assembly, 32", bypass
16	1060C	Cap, drain hose	100	925	Hose, 3/8" X 45" pump to heater
17	1130	Strap, velcro	102	152	"T", brass/ 1/4 npt
18	1060B	Hose, drain	104	FP373	Pump & motor, complete
20	91	Elbow, 90 degree, brass, 1/4 mpt	105	1062	Recepticle, power cord
21	1141	Washer, S/S	106	957	Pump, auto-dump
22	1146	Pipe, S/S, 1/4 mpt both ends	106A	1324	Hose Connector, k dump pump out
23	1143	Spacer	107	237	Cap, with chain
24	45	Quick Disconnect male, 1/4 pt	108	1325	Elbow, auto-dump
25	1184	Hose connector	109	1057B	Power Cord, 25 ft, yellow
26	1533	Connector, male garden hose	110	4405A	Relay, 20 Amp
27	1571	Bushing, 1" x 1/2"	110A	2025	Heat sink plate
28	1534	Elbow, 1" 90°	111	1164	Valve, power prime
29	2170	Locknut, 1"	111A	1299	Pedal, power prime
30	1320A	Bracket, Auto-fill valve mounting	112	1530C	Hose, to high press. outlet, 30"
31	1518	Hose Clamp	117	1280	Elbow, 90 degree, brass
32	907	Hose Barb, 1-1/2" hose	121	2084A	Wheel, 10"
33	1137	Adaptor, ABS, 1-1/2"	122	27A	Axle cap
33A	1140	Elbow, 90°, ABS	123	910-20.75	Axle, 1/2" X 21-3/4"
33B	1494	Bushing, ABS	124	1158	Plate, pump mounting
33C	1428	Strainer bag	125	16	Locknut, 6-32
33D	1465A	Cord lock	126	2B1	Screw, 6-32 X 2"
34	HKCR-1	Holding Tank, white	127	2015	Guard, fan
35	VKCR-1	Recovery Tank, white	128	2014	Fan, cooling, 100CFM
36	FP414	Reel, with hoses, complete	130	BKCR BLK	Base compartment, black
37	1309	Hose, power prime, 3/8" X 21.25"	131	108A	Elbow, 90 degree, pump outlet
38	166	Hose clamp	132	2066	Pump, 150 psi
39	946A	Hose, 1/2" 500 PSI, 17"	133	1081	Elbow, 90 degree, pump inlet
41	1115	Elbow, 90 deg, 3/8" hose X 1/4 mpt	135	905	Castor, 4"
46	1113	Hose Barb, elbow	135A	905A	Brake, for castor
47	92B	Nipple, PVC, 1/2 npt	136	1413	Clip Holder, for hose
48	207A	Filter, Pump inlet	137	FP416	Hose assy, low press. outlet
49	1401	Clamp, quick disconnect, small	138	1043A	Gasket
51	CWKC-BLK	Cord Wrap, black	139	219	Quick disconnect, male
61	1131	Elbow, PVC	140	91	Elbow, 90 degree
64	926	Manifold, vacuum	142	2166	Gauge, 1200 psi pressure
65	FP323	Vacuum motor, w/gasket, complete	143	908A	Latch
66	430	Vacuum hose, 1-1/2" X 7.75"	144	21C	Screw, 8-32 X 5/8"
66A	1136	Vacuum hose, 1-1/2" X 25 , clear	145	946A	Hose, 1/2" 500 PSI, 6-3/4"



TERMINATOR 120V

NOTES:

7905 N. 71st Avenue
Glendale, AZ 85303
PH: 623-414-4356