

BELFOR

KING COBRA[®] 500 120V

INFORMATION & OPERATING INSTRUCTIONS

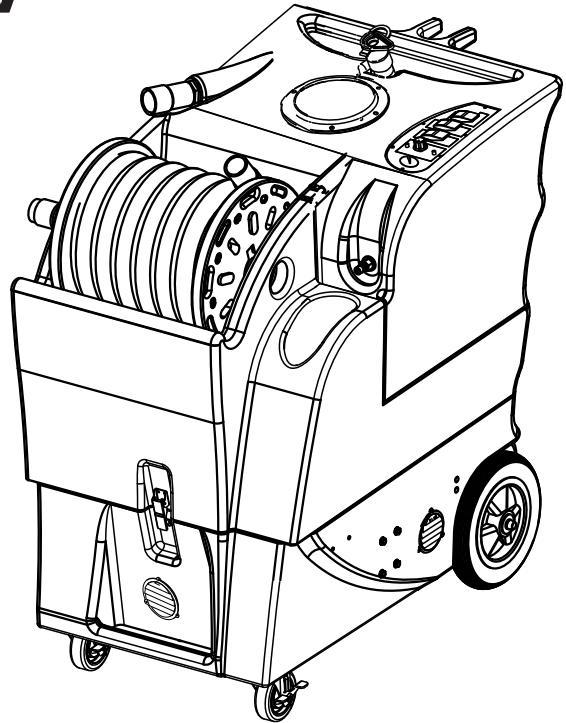

CAUTION: DO NOT OPERATE MACHINE UNTIL YOU HAVE READ ALL SECTIONS OF THIS INSTRUCTION MANUAL

IMPROPER USE OF THE MACHINE WILL VOID THE WARRANTY

1. Always use a defoamer when foaming occurs to prevent vacuum motor damage.
2. Keep machine from rain and snow, extremes in temperatures, and store in a heated location. Use the machine indoors. Do not use outdoors.
3. Do not let the pump run dry.
4. Use approved chemicals only. NO SOLVENTS.
5. Wear gloves or use rags when removing quick disconnects to prevent burns.
6. Never use water above 130° F/54° C in the solution tank.

IMPORTANT SAFETY INSTRUCTIONS

This machine is only suitable for commercial use, for example in hotels, schools, hospitals, factories, shops and offices other than normal residential housekeeping purposes. When using any electrical appliance, basic precautions should always be followed, including the following:

NOTE: Read all instructions before using this machine.



WARNING!

To reduce the risk of fire, electric shock, or injury:

- Do not leave the machine unattended when it is plugged in. Unplug the unit from the outlet when not in use and before servicing.
- To avoid electric shock, do not expose to rain or snow. Store, and use, indoors.
- Do not allow to be used as a toy. Close attention is necessary when used near children.
- Use only as described in this manual. Use only the manufacturer's recommended attachments.
- Never add water over 130° F/54° C to the solution tank.
- Do not use with damaged cord or plug. If the machine is not working as it should, has been dropped, damaged, left outdoors or dropped into water, return it to a service center.
- Do not pull by the cord, use the cord as a handle, close a door on the cord, or pull the cord around sharp edges or corners. Do not run the machine over the cord. Keep the cord away from heated surfaces. To unplug, grasp the plug, not the cord.
- Do not handle the plug, the cord or the machine with wet hands.
- Extension cords must be 12/3 and no longer than 50 feet. Replace the cord or unplug immediately if the ground prong becomes damaged.
- Do not put any object into openings. Do not use with any opening blocked; keep free of dust, lint, hair, and anything that may reduce air flow.
- Keep loose clothing, hair, fingers, and all parts of body away from openings and moving parts.
- Do not pick up anything that is burning or smoking, such as cigarettes, matches, or hot ashes, or any health endangering dusts. Do not use to pick up flammable or combustible liquids such as gasoline or use in areas where they may be present.
- Turn off all controls before unplugging.
- Use extra care when cleaning on stairs.
- Connect to a properly grounded outlet only.
- Liquid ejected at the spray nozzle could be dangerous as a result of its temperature, pressure, or chemical content.
- Always read chemical MSDS sheets before use.

INSPECTION:

Carefully unpack and inspect your KING COBRA-500 for shipping damage. Each machine is tested and inspected before shipping. Any shipping damage incurred is the responsibility of the carrier. You should notify the carrier immediately if you notice damage to the box or to the machine or parts.

CLEANING SOLUTIONS:

We recommend liquid cleaning chemicals. Powder chemicals may be used, but unless mixed very thoroughly they could cause a build-up in the pump, lines, heat exchanger and/or quick disconnects. Any problem caused by a chemical build-up is not covered by warranty. Use a neutral cleaner with a pH between 5 and 10 to avoid premature wear of the pump, seals, and/or other components. Damage caused by the use of strong chemicals (either acidic or alkaline) is not covered by the warranty.

MAINTENANCE:

For optimum performance flush the machine with clear water at the end of each working day. Once a month, minimum, run a flushing compound through the machine to break up any mineral or chemical build-up that may have formed. The vacuum motor, pump motor, and the pump do not require any scheduled maintenance; however, the motors may require replacement brushes after 1000 - 1500 hours. The pump may require rebuild kits after 1000 - 1500 hours, typically, and the pump unloader valve may need to be replaced after approximately 1000 - 1500 hours of use (refer to machine part list for numbers). Clean the body with an all purpose detergent, and protect it with an automobile interior polish. Lubricate the wheels, castors, and quick-disconnects with an all purpose silicone spray.

KC-500

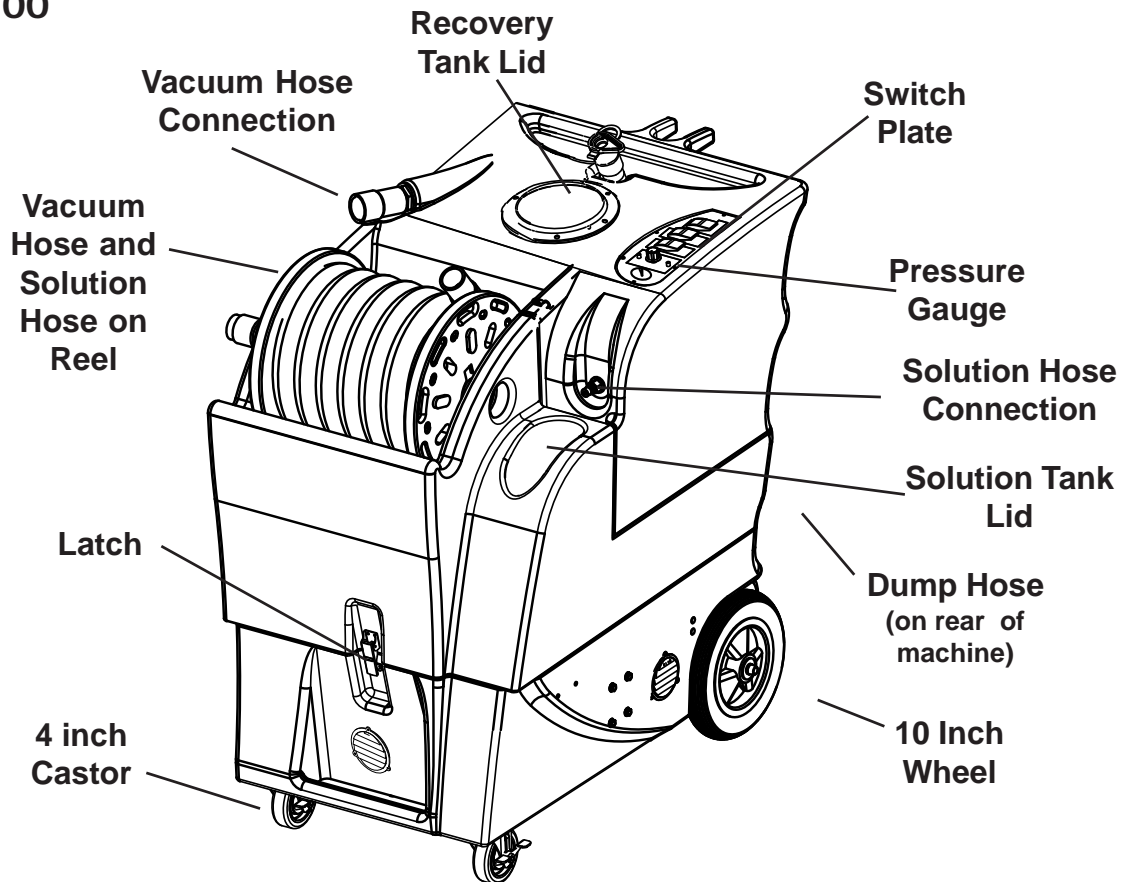

IMPORTANT INFORMATION

Record the serial number and model of your new extractor here:

(and be sure to mail your warranty card)

Serial Number: _____ Model: **KING COBRA-500-B**

Purchase Date: _____

Write the name and phone number of your distributor: _____

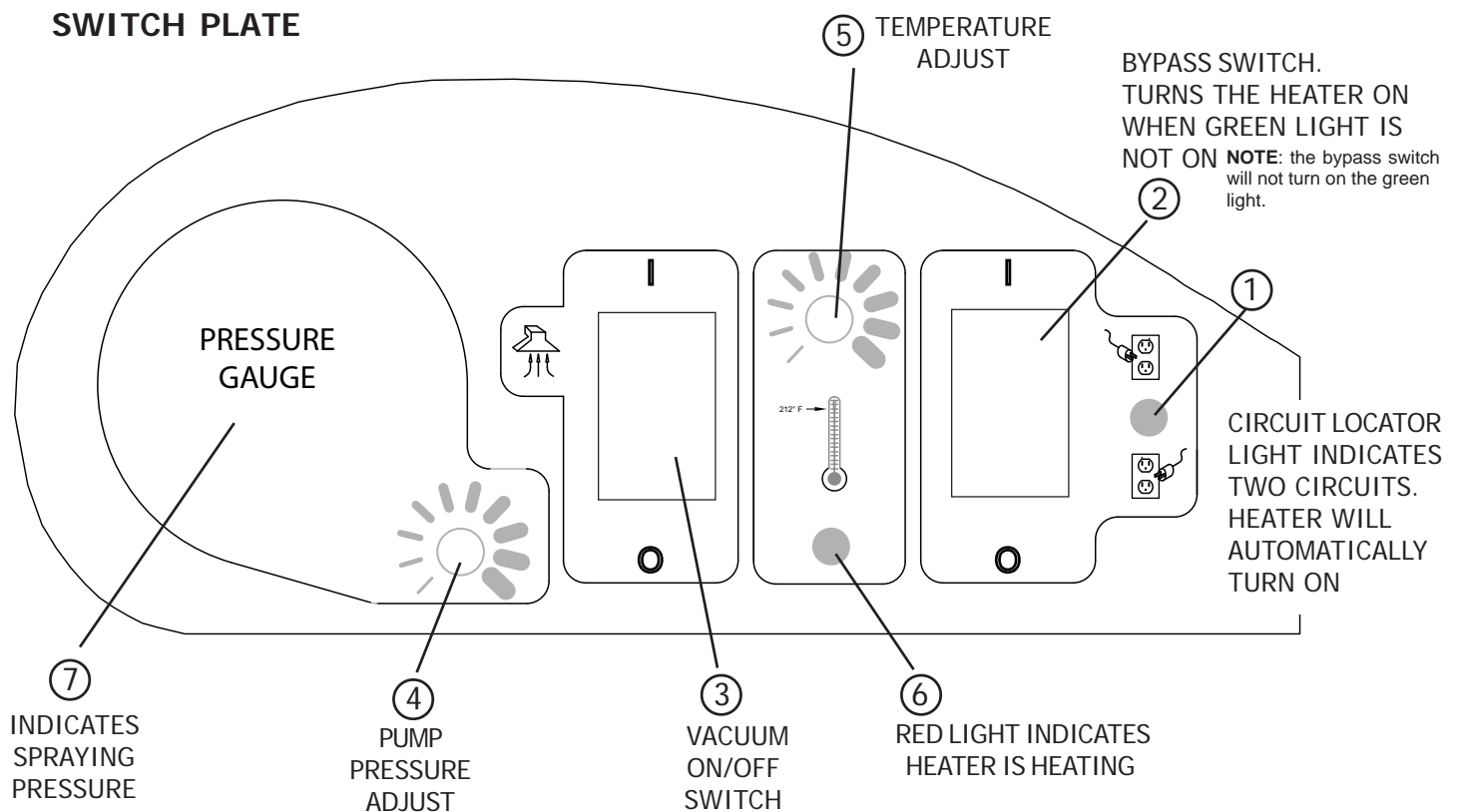

SET-UP and OPERATION

- 1 Inspect the machine, hoses, and cleaning tools for cleanliness and completeness.
- 2 Fill the solution tank with water. Using warm water may be a benefit in cleaning effectiveness, but do not use hot water (above 130° F / 54°C) in the tank.
- 3 Screw the lid on the recovery tank. Close the dump hose.
- 4 Plug in the power cords. Do not connect both cords to the same outlet; the green, circuit locator light (1) on the switch plate should light up. If the locator light does not come on, try different outlets until it does. If you are certain the cords are on separate circuits, turn on the Bypass switch (2) to engage the heat exchanger.

CAUTION: using the Bypass switch (2) when the cords are on the same circuit may cause the breaker in the wall to trip. **NOTE:** the receptacle on the left (viewed from behind the machine) powers the heater.

The red light (6) will turn on only when the heat exchanger is actively heating. It will turn off when the Heater reaches its maximum temperature. It will be on most of the time while you clean.

- 5 Connect the priming/siphon hose to the machine, turn the pump ON by turning the pump pressure knob (4) up to increase pump speed, and turn the vacuum switch (3) on. Hold the rubber 'cork' against the vacuum inlet hose barb on the recovery tank. The pump should prime between 20 - 60 seconds. Watch the water flow into the recovery tank through the clear lid. When the water is clear (no air in it) and flowing strongly, turn both the pump and the vacuum off, and remove the priming hose. Priming may take 20 - 60 seconds, and the solution tank should be full.
- 6 Add liquid cleaning chemical, with a pH between 6 and 9, to the solution tank.
- 7 Attach the spray hose (from the reel) to the solution quick disconnect and the vacuum hose to the hose barb on the recovery tank. Pull the hoses out from the reel. Attach the other ends of the hoses to the cleaning tool.
- 8 Set the temperature knob (5) to the desired heat setting. Allow the heat exchanger two minutes to reach operating temperature. The red light (6) will go out when the heater has reached operating temperature. **NOTE:** the red light will be on nearly all the time as you clean.
- 9 Turn the pump on by setting the pressure adjust knob to the desired spraying pressure (0 - 500 PSI). Read the spraying pressure at the pressure gauge (7) while spraying. **NOTE:** when you let off the trigger on the wand, the pressure gauge reading will drop to 0 psi; however, the spraying pressure will remain at the level to which you have set it. Turn the vacuum on (3). **NOTE:** the vacuum motor will start up slowly to prevent a large current surge.
- 10 Begin cleaning.
- 11 Use defoamer any time foaming occurs in the recovery tank.
- 12 Monitor the water level in the solution tank. Do not let the pump run dry.
- 13 When the solution tank gets low, turn off the pump and the vacuum, fill the solution tank, empty and clean the recovery tank.
- 14 When finished with the job, remove any unused solution from the solution tank, and run a few gallons of clean water through the system. Drain the recovery tank by placing the dump hose over a drain, or a bucket, and removing the cap. Disconnect the hoses from the cleaning tool, and reel them up onto the hose spool.

NOTE: To remove the reel, with hoses, from the machine, pull the vacuum hose loose from the hose barb on the front of the tank. Disconnect the solution hose quick coupling. Push Vacuum hose into the center of the hose spool. Grasp the spool from either side, and lift it off the machine. **NOTE:** before servicing any component in the base cabinet, the hoses and spool must be removed from the machine before the tanks can be lifted open.

ELECTRIC CIRCUIT LOCATOR

This unique, patented system is operated by a solid state circuit. It will inform the operator when the two cords are plugged into separate circuits by turning on the green, circuit locator light. This helps to prevent tripping circuit breakers. **NOTE:** if the green, circuit locator light does not illuminate when the cords are plugged in, then both cords are on the same circuit. Try other outlets with one of the cords until you get the locator light to come on. **NOTE:** if the bypass switch is turned on when both cords are on the same circuit, the breaker in the wall may trip.

ELECTRONIC FLOAT SHUT-OFF

When the recovery tank is full, the electronic float switch will turn the vacuum motor off. This will prevent water from entering the vacuum motor. The float may not work properly if the float filter rod is dirty or if there is heavy foam in the tank. To reset, turn the Vacuum switch off, and empty the tank.

 **CAUTION:** to avoid vacuum motor damage, always make sure the float filter is clean and that it can travel freely before you operate the machine. Use a defoamer any time foam is present.

KC-500

120V-240V

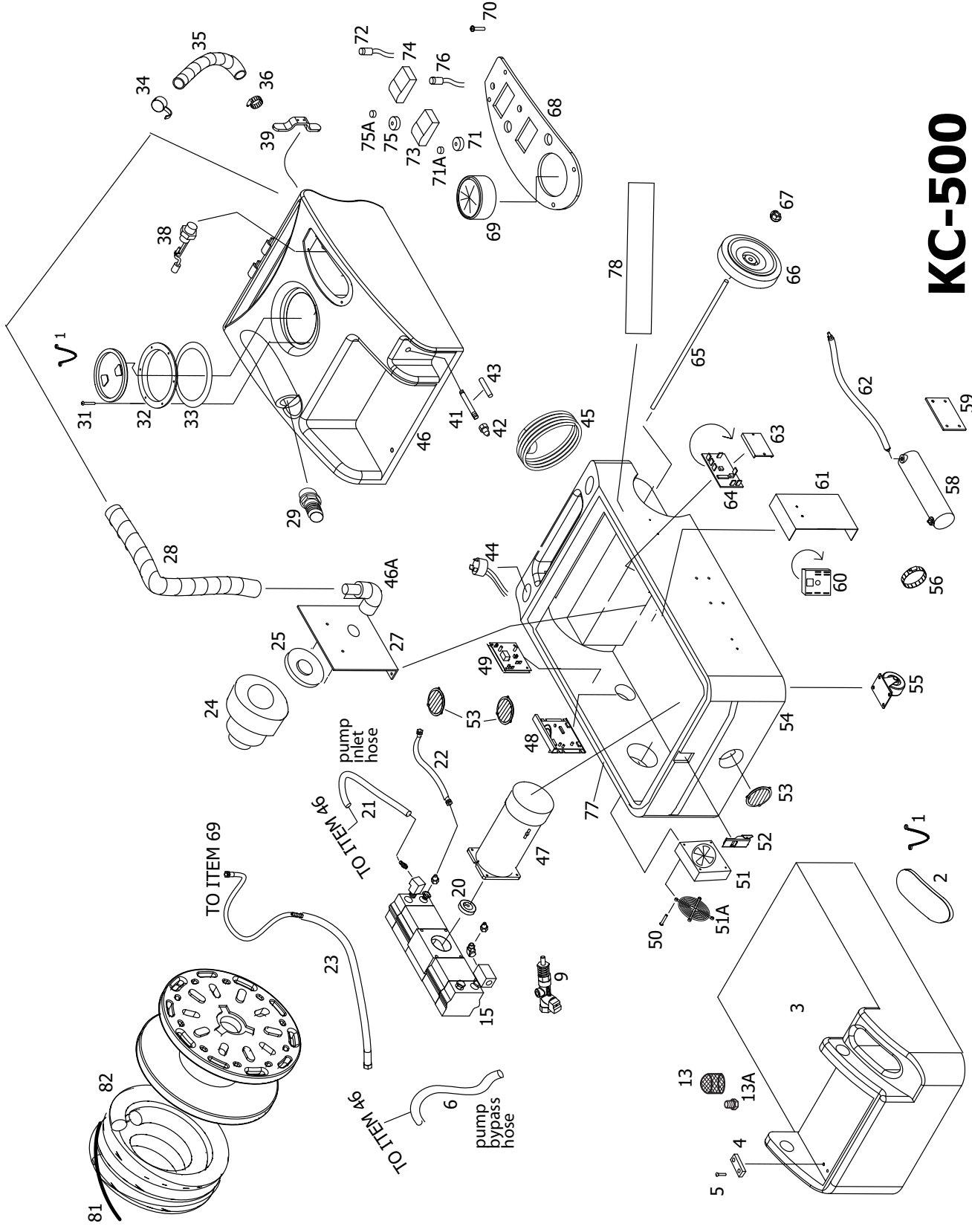

KING COBRA-500 EXTRACTOR

120V PART LIST 240V

<u>ITEM</u>	<u>PART No</u>	<u>DESCRIPTION</u>	<u>ITEM</u>	<u>PART No.</u>	<u>DESCRIPTION</u>
1	805	Chain, lid, 8"	51A	2015	Guard, fan
2	901B	Lid, solution tank	52	908A	Latch, draw, rubber
3	HKCR-RED	Holding Tank, red	53	928	Louver, 3", includes 3 screws
4	1088	Glide, teflon	54	BKCR-BLK	Base, black
5	331	Screw, 6-32 X 1/4"	55	905	Castor, 4"
6	925	Hose, 3/8" X 24" pump bypass	56	198	Hose clamp
7	164	Hose barb, brass, 3/8" hose	58	FP348	Heat exchanger, 120V
8	91	Elbow, 90 degree	59	455	Bracket, mounting, heater
9	945D	Valve, pump unloader	60	----	See miscellaneous Parts and Kits
10	92A	Nipple, S/S	61	918	Plate, heat sink
11	216	Elbow, brass	62	FP348A	Hose, heater to outlet
12	168	"T", brass, 1/4 p.t.	63	FP336	Snap track, PCB mounting, 4", 120V only
13	207A	Filter, pump inlet, 40 mesh	64	923B	PCB, circuit sensor, 120V only
13A	92B	Nipple, plastic	65	910-21.00	Axle, 21"
14	211	Plug, brass, 1/4 p.t.	66	2084	Wheel, 10"
15	FP410	Pump complete, no motor	67	27A	Axle cap
16	97	Reducer, brass	68	943B	Switch plate
17	223	Quick connect, male, 1/8 p.t.	69	951B	Pressure gauge
18	165	Hose barb, brass, 1/2" hose	70	28	Screw, #4 X 3/8"
19	1147	Cap screw, pump to motor	71	FP399	Potentiometer, with cable, pump
20	950D	Cam/bearing assembly	71A	248	Knob, blue top, for pump speed
21	946	Hose, 1/2" X 22-1/2" pump inlet	72	78	Light, green, neon 120V
22	FP348B	Hose, pump to heater, 12"	73	FP345	Switch & actuator, vacuum
23	FP411	Hose assembly, pump to gauge	74	FP346	Switch & actuator, bypass
24	913	Vacuum motor, 3-stage, 120V	75	FP347	Potentiometer, with wires, heat
25	959	Gasket, vacuum motor	75A	248	Knob, red top, for heat adjustment
27	926	Manifold, vacuum motor mount	76	78B	Light, red, neon, 120V
28	1136	Hose, vacuum inlet, 1-1/2" X 24 "	77	FP351	Gasket, (#1043A X 84")
29	907	Hose barb, for vacuum hose	78	2172	Label, Belfor
31	1156	Screw, 8-32 X 1-1/8"	81	FP350B	Pressure line complete, 25' with swivel
32	2086A	Lid, vacuum, with ring	82	FP350A	Vacuum hose complete, 25' with swivel cuff
33	1074	Gasket, lid			
34	1060C	Plug, drain hose			
35	1060B	Hose, drain, 1-1/2" X 24"			
36	1518	Hose clamp			
37	207A	Filter, pump inlet			
38	2026	Float switch			
39	CWKC-BLK	Cord wrap, Black			
41	1146	Pipe, 6.85", S/S			
42	45	Quick connect, male, 1/4 p.t.			
43	1144	Rubber sleeve, 1/2" ID X 5"			
44	1062	Receptacle, power cord			
45	1057B	Power cord, 25 ft, 3/12, yellow			
46	VKCR-RED	Vacuum tank, red			
46A	1131	Elbow, PVC			
47	948B	Motor, pump, DC out, 120V			
48	FP361	PCB, pump motor speed, 120V			
49	FP225	PCB, vacuum control, 120V			
50	2B1	Screw, 6-32 X 2-1/4"			
51	2014	Fan, cooling, 120V			

MISCELLANEOUS PARTS AND KITS

FP194E	Heat repair kit includes probe, thermistor control, and thermal cutout. 120V
FP409	Pump & motor complete, w/unloader 500 psi, 120V
FP422	Pump & motor complete, 500 psi, 240V
950CP	Pump rebuild kit, valves and O-rings, 500 psi
250	Pump rebuild kit, piston and seals, 300/500
948C	Brushes, carbon, for pump motor (order 2)
FP350C	Vacuum hose & pressure line, complete, no reel
FP350	Vacuum hose & pressure line with reel, complete
FP469	16.5" Hose assembly with swivel, for reel 1130

(NOTE: Items in kits not sold separately.)

KING COBRA® 500

120V

SPECIFICATIONS:

Rotomolded Body: Lifetime Warranty

Vacuum: 7.2" 3-stage

VAC Shutoff: Electronic

Pump: Positive displacement, fully adjustable 0-500 psi

Waterlift: 135"

Heat: Fully adjustable 145° to 212° F

Heater: 2000 Watts

Weight: 122 lbs.

NOTES:

