

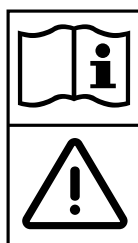

ADVANTAGE 1200 EXTRACTOR 120V

INFORMATION & OPERATING INSTRUCTIONS

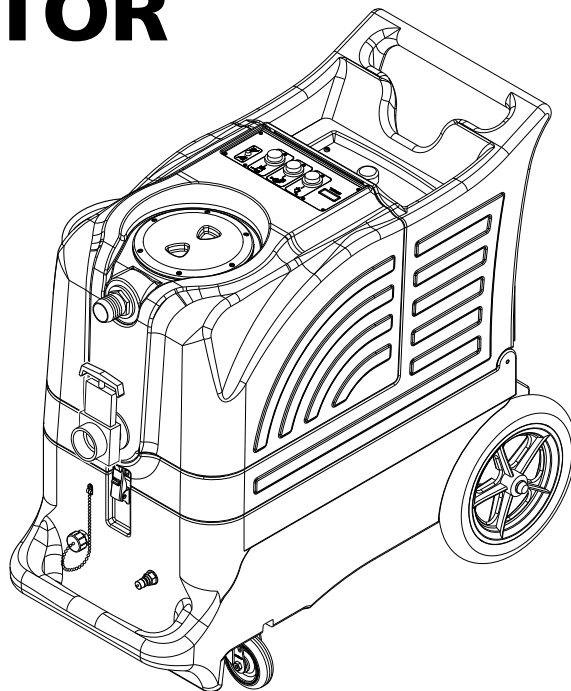

CAUTION: DO NOT OPERATE MACHINE UNTIL YOU HAVE READ ALL SECTIONS OF THIS INSTRUCTION MANUAL



IMPROPER USE OF THE MACHINE WILL VOID THE WARRANTY

1. Always use a defoamer when foaming occurs to prevent vacuum motor damage.
2. Connect the machine to a properly grounded outlet.
3. Keep machine from rain, snow, and extremes in temperatures. Store the machine in a heated location. Use the machine indoors. Do not use outdoors.
4. Use approved chemicals only. NO SOLVENTS.
5. Wear gloves or use rags when removing quick disconnects to prevent burns.
6. Never use water above 130° F/54° C in the solution tank.
7. Never turn on the solution pump without your solution line connected to the machine and the tool.

IMPORTANT SAFETY INSTRUCTIONS

The Advantage 1200 is only suitable for commercial use, for example in hotels, schools, hospitals, factories, shops, and offices. The Advantage 1200 is not intended for normal residential housekeeping purposes.

NOTE: Read all instructions before using this machine.

When using any electrical appliance, basic precautions should always be followed, including the following warnings:

WARNING!

To reduce the risk of fire, electric shock, or injury:

- Do not leave the machine unattended when it is plugged in. Unplug the unit from the outlet when not in use and before servicing.
- To avoid electric shock, do not expose to rain or snow. Use and store indoors.
- Do not allow to be used as a toy. Close attention is necessary when used near children.
- Use only as described in this manual. Use only the manufacturer's recommended attachments.
- Never add water over 130° F/54° C to the solution tank.
- Do not use with damaged cord or plug. If the machine is not working as it should, has been dropped, damaged, left outdoors or dropped into water, return it to a service center.
- Do not pull by the cord, use the cord as a handle, close a door on the cord, or pull the cord around sharp edges or corners. Do not run the machine over the cord. Keep the cord away from heated surfaces. To unplug, grasp the plug, not the cord.
- Do not handle the plug, the cord, or the machine with wet hands.
- Extension cords must be 12/3 and no longer than 50 feet. Replace the cord or unplug immediately if the ground prong becomes damaged.
- Do not put any object into openings. Do not use with any opening blocked; keep free of dust, lint, hair, and anything that may reduce air flow.
- Keep loose clothing, hair, fingers, and all parts of body away from openings and moving parts.
- Do not pick up anything that is burning or smoking, such as cigarettes, matches, hot ashes, or any health endangering dusts. Do not use to pick up flammable or combustible liquids such as gasoline or use in areas where these liquids may be present.
- Turn off all controls before unplugging.
- Use extra care when cleaning on stairs.
- Connect to a properly grounded outlet only.
- Liquid ejected at the spray nozzle could be dangerous as a result of its temperature, pressure, or chemical content.
- Never turn on the solution pump without first connecting your solution hose to your machine and to your tool.

INSPECTION:

Carefully unpack and inspect your ADVANTAGE 1200 for shipping damage. Each machine is tested and inspected before shipping. Any shipping damage incurred is the responsibility of the carrier. You should notify the carrier immediately if you notice damage to the box, the machine, or its parts.

CLEANING SOLUTIONS:

We recommend liquid cleaning chemicals. Powder chemicals may be used, but unless mixed very thoroughly they could cause a build-up in the pump, lines, and quick disconnects. Any problem caused by a chemical build-up is not covered by warranty. Use a neutral cleaner with a pH between 5 and 10 to avoid premature wear of the pump, seals, and/or other components. It is a good idea to test an inconspicuous area of the floor.

MAINTENANCE:

For optimum performance flush the machine with clear water at the end of each working day. Once a month, minimum, run a flushing compound through the machine to break up any mineral or chemical build-up that may have formed. The vacuum motor and the pump do not require any scheduled maintenance; however, the motor may require replacement brushes after 1000 - 1500 hours. Clean the body with an all-purpose detergent, and protect it with an automobile interior polish. Lubricate the wheels, castors, and quick disconnects with an all purpose silicone spray.

PARTS AND SERVICE:

Repairs, when required, should be performed by your authorized distributor who maintains an inventory of original replacement parts and accessories. Call the distributor from whom you purchased this machine if you need parts and service. Be sure to specify the machine model. Have your serial number handy.

Serial Number: _____

Model: ADVANTAGE 1200

Purchase Date: _____

Write the name and phone number of your distributor:

(and be sure to register your warranty: go on-line to www.usproducts.com)

SWITCH PLATE

MODEL (1):
This identifies the model of your machine.

VACUUM SWITCH (2):
This push-button switch turns on the vacuum. The switch will illuminate when it is on.

AUTO DUMP SWITCH (3):

This pump switch will illuminate when it is activated, and it will turn on the automatic pump-out pump.

SOLUTION PUMP SWITCH (4):

The solution pump switch will illuminate when it is activated, and it will turn on the solution pump. The output pressure of this pump is adjustable through the unloader valve. Refer to the drawing below, and to the Operation instructions

GREEN, TWO CIRCUIT INDICATOR (5):

This light will automatically turn on when you have plugged the two power cords into separate circuits. If this light does not turn on, try other outlets with one of the cords until the light does turn on.

NOTE: All systems in the machine will operate if this light does not turn on, but you may trip a circuit breaker in the wall.

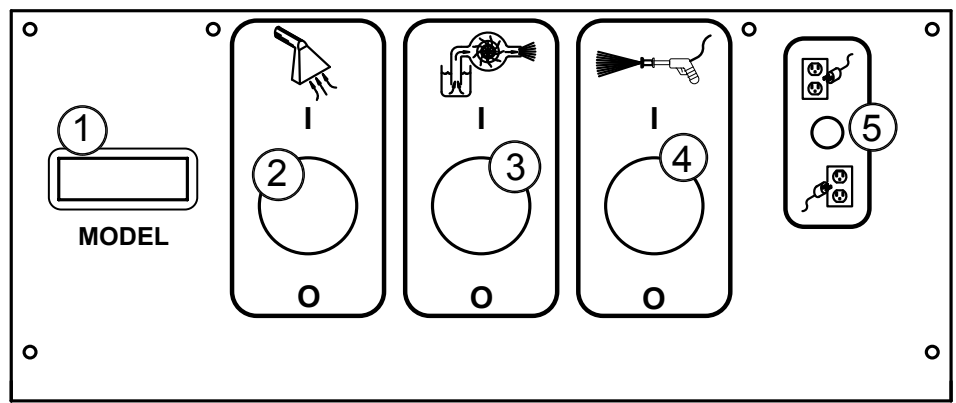

YOUR MACHINE

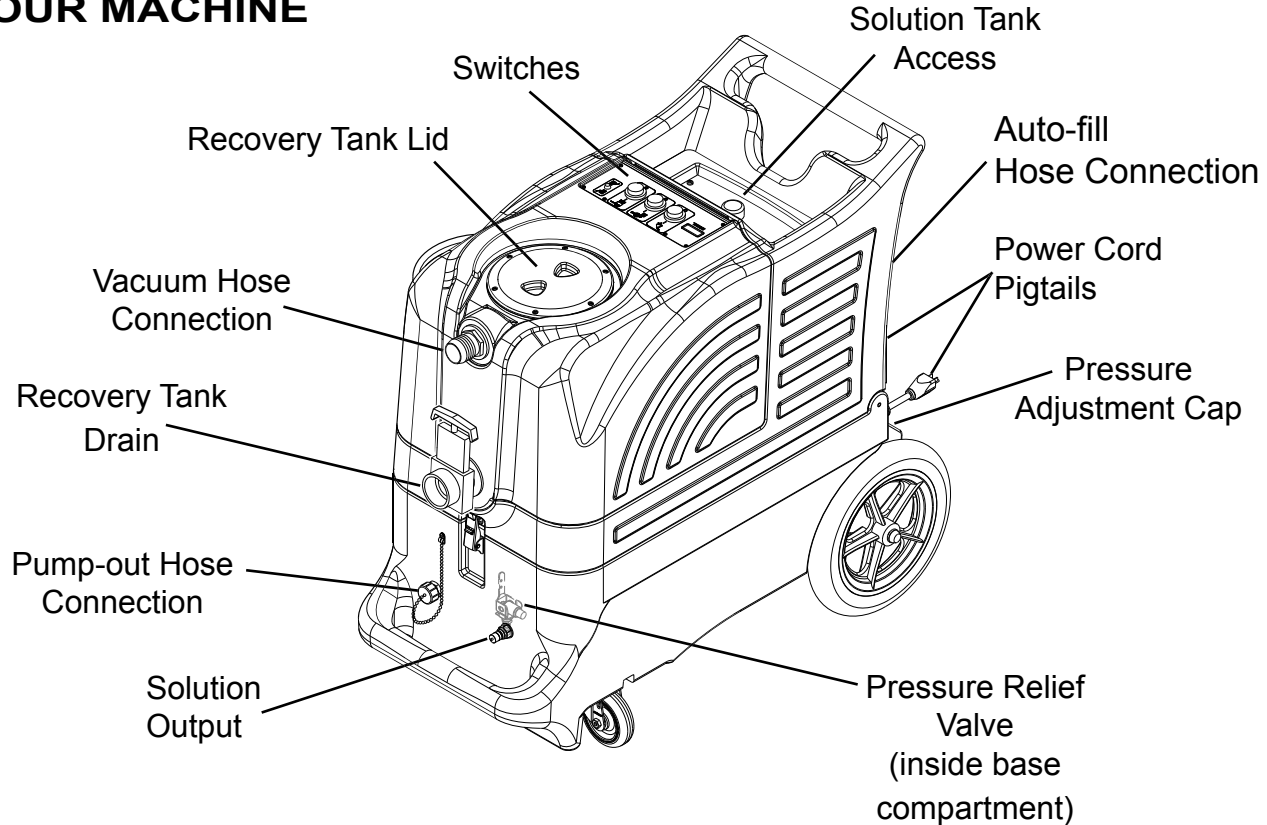

SET-UP & OPERATION

1. Before each use, inspect the machine, hoses, and cleaning tools for cleanliness and completeness. Make sure hoses are in good condition and the spray nozzle(s) is tight.
2. If not using the auto-dump feature, just make sure the brass cap is on the drain hose connector on the front of the base of the machine.

If you choose to use the auto-dump feature, remove the brass cover on the hose connector on the front of base of the machine, attach a hose, and place the open end of the hose in a drain. Make sure the recovery tank drain gate is closed, and the lid is tight on the recovery tank.

3. If you choose not to use the auto-fill feature, just **fill** the tank with water and cleaning chemical. Follow chemical directions regarding dilution and mixing. Do not use harsh chemicals; they may damage seals in pumps and valves, and cause the pump to wear prematurely.

If you choose to use the auto-fill feature, connect the fill hose to the auto-fill connector (located over the solution tank fill hole). Turn on the water source -- HIGH PRESSURE IS NOT NECESSARY -- and allow the tank to fill with water. When using the auto-fill system, the auto-fill float will automatically turn on and turn off as the tank empties and then fills.

NOTE: Never put water with a temperature exceeding 130 °F / 54 °C in the solution tank

4. Pre-spray the area to be cleaned, with a pump-up sprayer, while the tank is filling. Follow chemical directions.
5. Plug in the two power cords. Do not connect both cords to the same outlet. The green, 'separate circuit' locator light (1) on the switch plate should light up. If the locator light does not come on, check the circuit breaker box in the wall, and/or try different outlets until it does turn on. Although all systems in the machine may work correctly if you are not on two circuits, a circuit breaker in a wall panel may trip. If you make sure the green light is turned on, you will prevent tripped circuit breakers.
6. Prime the 1200 psi pump: fill the solution tank with water, if not already done, and turn on the pump. You may notice a 'tone' change in the sound of the pump (smoother, with less of a rattle).

CAUTION -- NEVER TURN ON THE SOLUTION PUMP BEFORE CONNECTING YOUR SOLUTION LINE TO YOUR MACHINE AND TO YOUR TOOL. If the pump builds pressure before you connect the hose and tool, you will not be able to connect them. If this occurs press the lever on the pressure relief valve.

7. **Use defoamer to prevent foam.**
8. Attach the solution spray hose to the solution quick disconnect. Attach the vacuum hose to the hose barb on the front of the recovery tank. Connect the other ends of the hoses to the tool.
9. Turn on the vacuum (2) and turn on the dump pump (3). Begin spraying.
10. When the job is finished, turn off the water source. Vacuum the remaining solution from the solution tank into the recovery tank.
11. Run a few gallons of clean water through the system. Drain the recovery tank by opening the drain gate over a bucket or drain. Disconnect the hoses from the cleaning tool.
12. Unplug the power cords. Clean the machine and the tool.

NOTE: if the green, circuit locator light does not illuminate when the cords are plugged in, then both cords are on the same circuit. Try other outlets with one of the cords until you get the locator light to come on.

AUTO VACUUM SHUTOFF:

When the recovery tank is full, the ball float will shut-off the suction to prevent the machine from overflowing.

NOTE: the float may not work if there is foam in the tank. **Always use defoamer to prevent overflow.**

AUTO-FILL

1 Operation:

- Attach a 3/4" garden hose to the auto-fill valve, and connect the other end of the hose to your water source.
- Make sure the float that hangs from the auto-fill valve into the tank is free of obstruction and can move freely.
- Turn the water supply on.
- The auto-fill float will automatically shut-off the flow of incoming water when the solution tank is nearly full, and it will allow the valve to open again once the water level has dropped to a predetermined level.

AUTO-DUMP

1 Operation:

- **Before each use:** if necessary, unscrew the stainless steel filter at the bottom of the recovery tank and clean it. Also make sure the float in the recovery tank is clean.
- Attach a 3/4" garden hose to the dump pump outlet fitting on the back of the base of the machine.
- Run the other end of the hose into a drain.
- Turn ON the dump pump switch (switch is located on the switch panel on the top of the machine).
- **NOTE:** the dump pump is 'self-priming.' You should see water start to flow within 30 seconds of the pump turning on. If water does not begin to flow, check the filter to see if it is plugged with debris.
- **After each job:** run clear water through the dump pump to wash out any chemical residue. Remove and clean the filters in the back of the recovery tank. Reinstall the filter once it is clean. Clean and empty the recovery tank.



DANGER: DO NOT USE SOLVENTS, OR ANY CHEMICALS THAT MAY BE FLAMMABLE, EXPLOSIVE, OR COMBUSTIBLE.

CAUTION: always use a defoamer in the recovery tank to prevent water or foam from entering the vacuum motor.

CAUTION: Use care when handling hazardous chemicals.

CAUTION: Never put water hotter than 130 °F / 54 °C in the holding tank.

CAUTION: Never leave the 1200 psi pump running when you are not actively using it.

ADVANTAGE 1200 120V

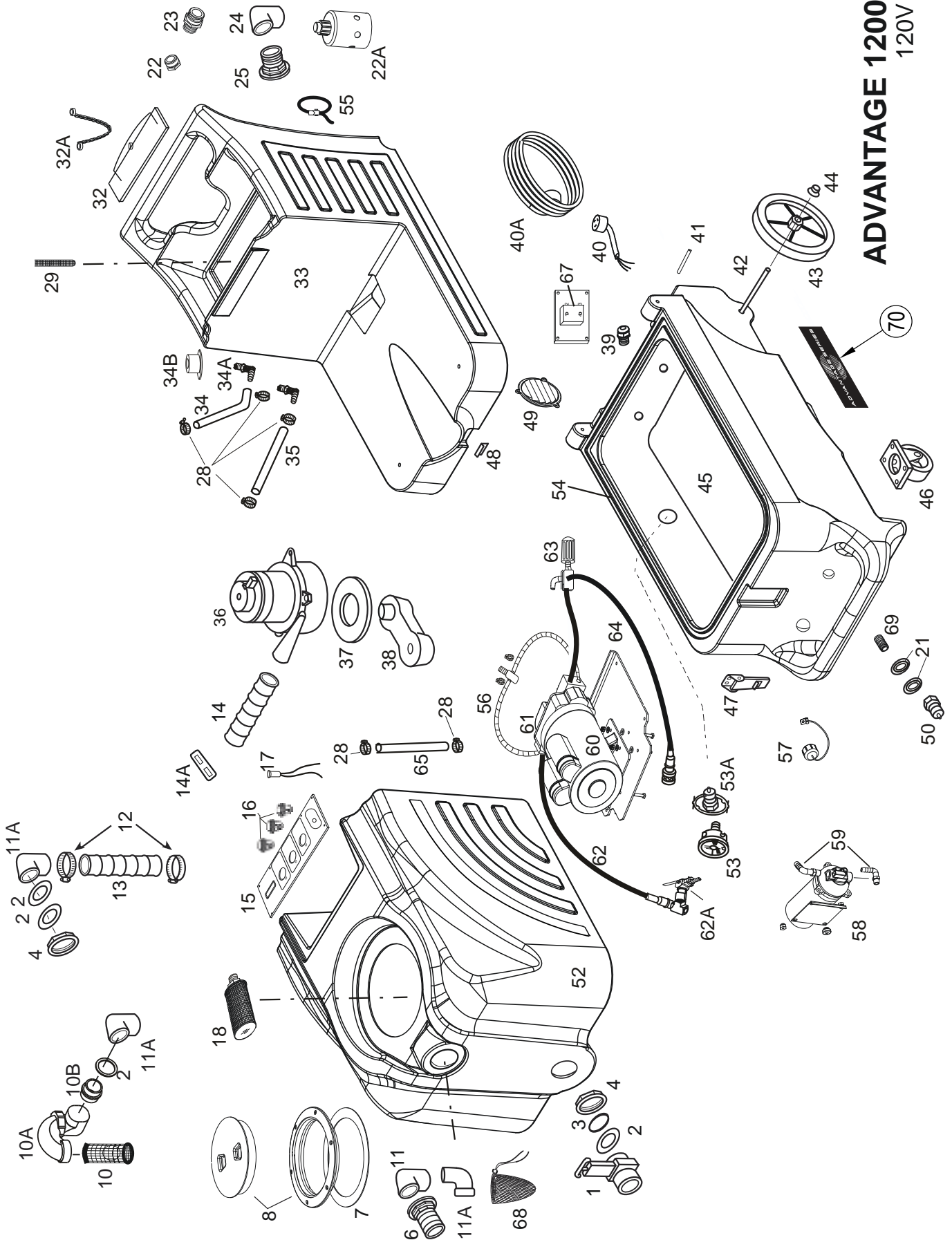

ADVANTAGE 1200 120V

Item	Ref. No.	Qty	Description	Item	Ref. No.	Qty	Description
1#	903USP	1	Drain Gate	36	408G	1	Vacuum, 3-stage
2	187B	2	Washer, rubber	37	2013	1	Gasket, vacuum
3#	187USP	1	O-Ring	38	MA-6	1	Manifold, vacuum
4#	185USP	1	Nut, 1-1/2"	39#	230USP	2	Retainer, cord pigtail
6	907	1	Hose Barb, vacuum inlet	40	2155	2	Pigtail, power cord
7	1074	1	Gasket	40A	2154	2	Power cord, 25 ft
8	2086A	1	Lid with Ring, 6"	41	801	2	Hinge pin
	56380968	1	O-Ring for 2086A Lid	42#	910-1863	1	Axle rod, 18.63"
10	929B	1	Ball Float, vac shut-off	43	2092	2	Wheel, 12 inch
10A	1154A	1	Adapter, ABS trap	44#	27AUSP	2	Axle cap
10B	1154	1	Adapter, ABS	45	FP627D	1	Base, complete
11#	922USP	2	Elbow, PVC, FPT	46#	905USP	2	Castor
11A	1140	1	Elbow, 90°, ABS	47#	56471194	1	Latch
12#	156USP	2	Hose Clamp	48	909A	1	Catch, for latch
13	430	25.5"	Hose, vacuum, 2"ID X 25.5"	49#	459USP	1	Louver, 2-1/2"
14	430A	1	Hose, vacuum, 2"ID X 13.5"	50#	45USP	1	Quick disconnect
14A	4404C	1	Bar, vacuum hose hold-down	52	FP629	1	Recovery tank
15	FP617	1	Switchplate, Advantage	53	2166	1	Pressure gauge
16	1623R	3	Switch, push-button, ON/OFF	53A#	219USP	1	Quick disconnect
17	227	1	Green light	54	2050	1	Gasket, 78.5"
18	2069B	1	Filter, inlet 30 mesh	55	1603	2	Strap, cord wrap
21	31	1	Washer, brass	56	FP630	1	Hose assy, pump intake
22	1184	1	Adaptor, garden hose	57	237	1	Cap with chain, drain hose
22A	1310A	1	Valve, water inlet	58	2067	1	Pump, dump
23	1533	1	Connector, hose adaptor	59	1546	2	Hose barb, two per bag
24	1534	1	Elbow, 1" 90°	60	FP636	1	Motor, no pump
25	1571	1	Bushing, 1" x 1/2" PVC	61	FP657	1	Pump, complete, no motor
28#	166USP	4	Hose Clamp	62	FP632	1	Hose, unloader to outlet
29	1557A	1	Screen, filter	62A	FP656	1	Valve, pressure relief
32	2175	1	Lid, Solution tank	63	FP633	1	Unloader valve assembly
32A#	805USP	1	Chain, 8"	64	FP631	1	Hose, pump to gauge
33	TKC-6	1	Solution tank	65	946	1	Hose, dump pump inlet, 32"
34	946	1	Hose, pump inlet, 1/2" ID X 15"	67	4405A	1	Relay, 25 AMP
34A	2176	1	Elbow, 1/2" ID, 90°	68	FP619	1	Pre-filter bag
34B	2177	1	Grommet, rubber	69#	92AUSP	1	Nipple, s/s
35	925	1	Hose, pump bypass, 3/8" ID X 13"	70#	2162	2	Label Advantage Series
				*	FP618		Pump and motor, complete
				*	1160K		Pump rebuild kit, valves & O-rings
				*	1160A		Pump rebuild kit, plunger and seals
				*	FP655		Solution hose assembly, 25 ft.

* = Optional, Not Included

[] = Not Shown

= Revised or new since last update

MAINTENANCE SCHEDULE

	DAILY	WEEKLY	MONTHLY	YEARLY	OTHER
CLEAN ALL FILTERS	X				
CHECK POWER CORD	X				
FLUSH OUT with DESCALER			X		
REPLACE VAC MOTOR BRUSHES					Around 1500 hours
REPLACE PRESSURE REGULATOR				X	Or as needed
REBUILD PUMP					Around 1500 hours

TROUBLE SHOOTING:

<u>IF THIS OCCURS</u>	<u>CHECK THIS</u>
NO SPRAY	Solution tank is empty. Clogged spray tip. Pump not running or not primed. Valve on wand not operating.
LOW SUCTION	Debris is plugging cleaning tool or vacuum hose. Drain hose is not completely closed. Vacuum tank lid is not closed or seal is damaged.
NO SUCTION	No power to motor. Test the switch. Test the vacuum motor.



425-322-0133 / 800-257-7982 / FAX: 425-322-0136
11015 - 47th Ave. W. / Mukilteo, WA 98275
VISIT US AT: <http://www.usproducts.com>