

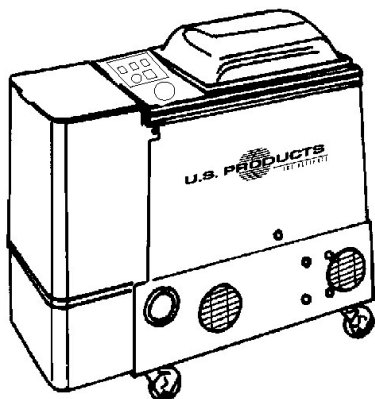

THE ULTIMATE[®]: PB111 EXTRACTOR 120V

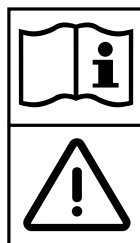

INFORMATION & OPERATING INSTRUCTIONS



**DO NOT OPERATE MACHINE UNTIL YOU HAVE READ ALL SECTIONS OF THE INSTRUCTIONS
IMPROPER USE OF THE MACHINE WILL VOID THE WARRANTY**

1. Never use the Booster Heat when solvent is in the machine.
2. Never attempt to heat solvent above 130 °F.
3. Always use a nonflammable solvent with a flash point of 140 °F or higher.



DO NOT SMOKE WHEN USING HYDROCARBON-BASED SOLVENTS

Even solvents with a flash point above 140 °F can be ignited, especially as an aerosol from the wand.



4. The recovery bucket should be emptied each time the holding tank is filled.
5. Always make sure the float travels freely up and down the rod after emptying the recovery bucket.
6. Always vacuum out the stainless steel tank and solution lines when switching from a solvent to a water based detergent, and vice versa (see Operating Instructions).
7. Always use a drop cloth under the machine during operation.
8. Vacuum any unused solution out of the solution tank and empty the recovery bucket after each job.
9. Keep machine from rain and snow, extremes in temperatures, and store in a heated location. Use the machine indoors. Do not use outdoors.
10. Do not run the pump dry.
11. Never operate a machine that is leaking or in need of a repair.
12. Always use a defoamer. The vacuum shut-off will not activate properly if foam is in the recovery bucket. Water damage to the vacuum motor or other components will void the warranty.

If you have any questions before you operate the machine, call your supplier for instruction.

IMPORTANT SAFETY INSTRUCTIONS

This machine is only suitable for commercial use, for example in hotels, schools, hospitals, factories, shops and offices other than normal residential housekeeping purposes.

When using any electrical appliance, basic precautions should always be followed, including the following:

NOTE: Read all instructions before using this machine.

WARNING!

To reduce the risk of fire, electric shock, or injury:

- Do not leave the machine unattended when it is plugged in. Unplug the unit from the outlet when not in use and before servicing.
- To avoid electric shock, do not expose to rain or snow. Store, and use, indoors.
- Do not allow to be used as a toy. Close attention is necessary when used near children.
- Use only as described in this manual. Use only the manufacturer's recommended attachments.
- Never add water over 130° F/54° C to the solution tank.
- Do not use with damaged cord or plug. If the machine is not working as it should, has been dropped, damaged, left outdoors or dropped into water, return it to a service center.
- Do not pull by the cord, use the cord as a handle, close a door on the cord, or pull the cord around sharp edges or corners. Do not run the machine over the cord. Keep the cord away from heated surfaces. To unplug, grasp the plug, not the cord.
- Do not handle the plug, the cord or the machine with wet hands.
- Extension cords must be 12/3 and no longer than 50 feet. Replace the cord or unplug immediately if the ground prong becomes damaged.
- Do not put any object into openings. Do not use with any opening blocked; keep free of dust, lint, hair, and anything that may reduce air flow.
- Keep loose clothing, hair, fingers, and all parts of body away from openings and moving parts.
- Do not pick up anything that is burning or smoking, such as cigarettes, matches, or hot ashes, or any health endangering dusts. Do not use to pick up flammable or combustible liquids such as gasoline or use in areas where they may be present.
- Turn off all controls before unplugging.
- Use extra care when cleaning on stairs.
- Connect to a properly grounded outlet only.
- Liquid ejected at the spray nozzle could be dangerous as a result of its temperature, pressure, or chemical content.
- Use a respirator and gloves when using dry cleaning solvents. In addition, a fan or blower is helpful to blow fumes away from the operator.
- Always work in a well ventilated area.
- Always work with the exhaust hose attached to the machine when using solvents.

INSPECTION:

Carefully unpack and inspect your #770 Ultimate for shipping damage. Each machine is tested and inspected before shipping. Any shipping damage incurred is the responsibility of the carrier. You should notify the carrier immediately if you notice damage to the box or to the machine or parts.

CLEANING SOLUTIONS:

The #770 Ultimate is capable of either wet or dry cleaning. Only liquid cleaners are recommended (no powders). Solvents with a flash point of 140° F or higher are required for safety. Solvents are normally used full strength. Water based cleaners are normally diluted. Follow label directions. The stainless steel holding tank can be filled with up to 3 gal. of cleaning solution.

MAINTENANCE:

For optimum performance, flush the machine with clear water at the end of each working day. Once a month, minimum, run a flushing compound through the machine to break up any mineral or chemical build-up that may have formed. Clean the float rod each time the recovery bucket is emptied. Inspect the filters regularly and clean as needed. The vacuum filter is located under the recovery bucket. The solution filter is located at the bottom of the holding tank. The quick disconnects and castors can be lubricated with a penetrating spray lubricant. Fine steel wool will keep the brass quick disconnects shining. An auto interior spray cleaner/protectant will work well to keep the body clean and bright.

Serial Number: _____

Model: Ultimate PBIII 120-B

Purchase Date: _____

Write the name and phone number of your distributor:

(and be sure to register your purchase to activate your warranty)

SPECIFICATIONS:

- Construction: Stainless steel and hexane copolymer for use with solvents and water based detergents
- Vacuum: 80" water lift - 97 CFM
- Heat Exchanger: Stainless steel coil, instant heat transfer
- Circuit Board: Solid-state technology, long life monitoring system controls heating operation (sensing within 1° F)
- Sensing Systems: Solid state circuitry
- Solvent Sensing Probe: Determines whether there is solvent or water-base cleaning in holding tank. (Patented) Unique fail safe system automatically prevents solvent from heating above 125° F regardless of heat setting
- Pump: Centrifugal type 40 psi carbon and ceramic seals and brass head, slide-mount and compression fittings for quick removal and servicing
- Electrical System: 25 ft. 12/3 cord available in 120 & 240V 50/60 cycle
- Weight: 46 lbs.
- Dimensions: 23L x 22H x 10W

Set-Up

- 1 Make sure the recovery bucket is in place under the dome and in the correct position. The dome must be flat or it won't seal properly.
- 2 Fill the stainless steel holding tank with cleaning solution, to the desired level. Solution must be at least 3" above the filter in the bottom of the tank. **NOTE:** Attach the exhaust hose when dry cleaning.
- 3 Position the cleaning tool over the holding tank, and depress the trigger. Turn the pump on (center switch). Allow the solution to spray for several seconds, to fill the lines.
- 4 **SOLVENT HEATING:** turn on the Heater switch only. Make sure the Booster Heat switch is turned completely off. Wait two minutes for the heater to reach operating temperature. Spray over the holding tank again, for about 15 seconds, to preheat the solution line and the tool. **NOTE:** the heat will shut off completely if the Booster Heat is turned on with solvent in the tank. Go to Step 5.

WATER HEATING: turn on the Heater switch, and position the Booster switch to the desired temperature. Wait 2 minutes for the heater to reach operating temperature. Spray over the holding tank for 15 seconds to preheat the solution line and the tool. Wait 30 seconds, then spray again for 15 seconds. Go to Step 5.

- 5 Turn on the Vacuum switch (first switch). All rocker switches should be turned on now. You are now ready to begin cleaning.
- 6 When the recovery bucket is full, the vacuum will automatically shut off. Turn the vacuum switch off. Remove the dome and lift the bucket out. Empty the bucket, and wipe off any spillage from the outside of the bucket. Reinstall the recovery bucket and the dome.
- 7 Make sure the float in the bucket travels freely up and down the rod each time you empty the recovery bucket.

TO SWITCH CHEMICAL BASE

- 8 When switching from a solvent-based product to a water-based detergent, or vice versa, use the following procedure: turn off all the switches, except the vacuum switch. Leave the vacuum hose in the dome, and disconnect the hoses from the tool. Place the open end of the vacuum hose into the solution tank, and vacuum out any remaining solution. Place the hose over the filter in the tank for 10 seconds.
- 9 Connect the end of the solution line to the black suction plug. Take the vacuum hose out of the dome, and place the plug in its place. Let the vacuum run for 20 - 30 seconds to pull all the solution out of the lines and the heater. **NOTE: DO NOT LET THE PUMP RUN DRY.**

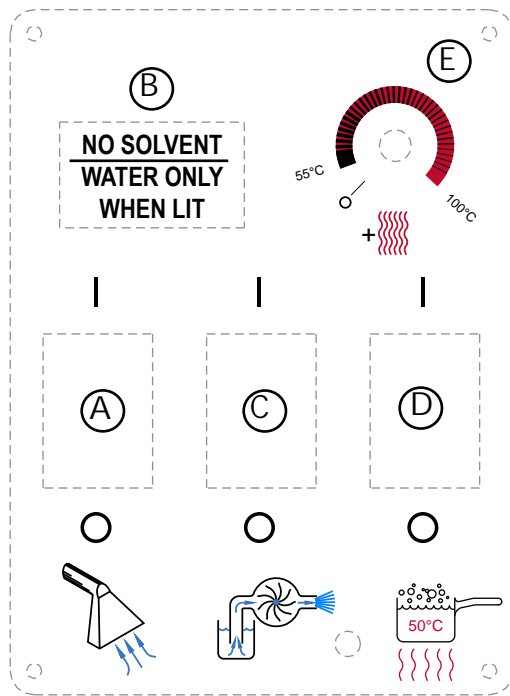

- (A) = VACUUM
- (B) = WARNING INDICATOR
- (C) = PUMP
- (D) = HEAT
- (E) = BOOSTER HEAT

SOLVENT HEATING: Turn on the Heater Switch (D). The Booster Heat switch (E) must be all the way off (turned counterclockwise until it 'clicks' off) or the machine will not heat at all.

WATER HEATING: Turn on the Heater Switch (D). Turn on the Booster Heat Switch (E) to the desired temperature, 130 - 200 °F.
NOTE: Booster Heat will not work unless the Heat switch is on.

WATER ONLY NO SOLVENT (E): This indicator light (B) illuminates when the Booster Heat switch (E) is turned on. It is a reminder that the Booster Heat will only work with water-based solutions.

⚠ CAUTION: **USE A RAG TO DISCONNECT BRASS FITTINGS AFTER USING THE BOOSTER HEAT. THE FITTINGS CAN GET VERY HOT AND MAY CAUSE MINOR BURNS.**

AUTO VAC SHUT-OFF: When the recovery bucket is full, the vacuum motor will automatically shut off. The float in the bucket may not be raised by foam. Defoamer must always be used to avoid water damage to the vacuum motor.

SOLVENT SENSING SYSTEM: This unique, patented system determines whether there is solvent or water-based solution in the tank. If solvent is used, the sensor will automatically prevent heating above 140 °F. To prevent accidental over-heating of solvent, the use of the Booster heat switch - with solvent in the tank - will cause the entire heat system to shut off.

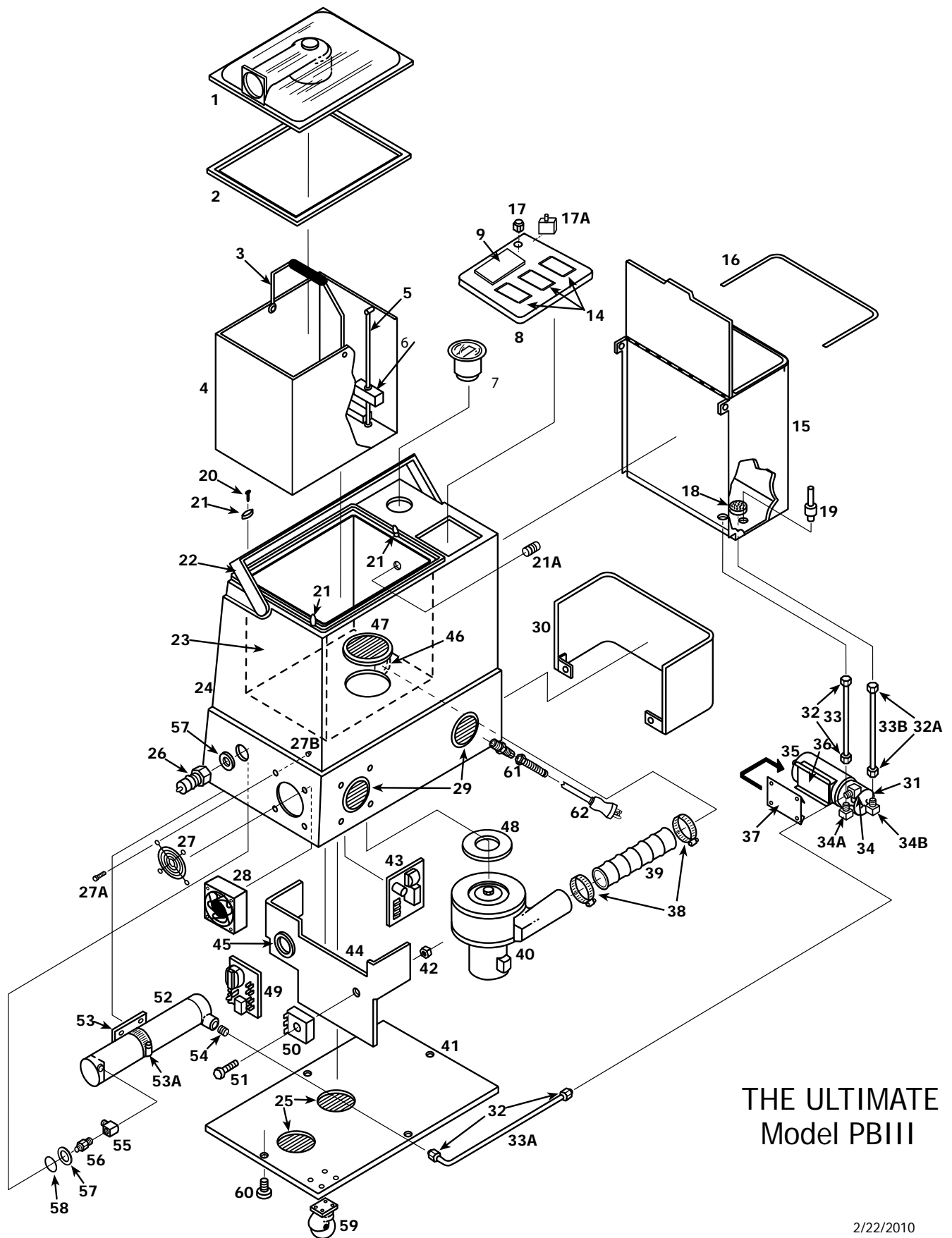

THE ULTIMATE
Model PBIII

2/22/2010

ULTIMATE PB111

PARTS LIST

ITEM PART # DESCRIPTION

1	FP368	Vacuum Dome, no Gasket
2	439	Gasket, for dome
3	420	Handle, recovery Bucket
4	FP147	Recovery Bucket, complete
5	421	Float Rod
6	FP184	Float Assembly
7	423-120-240	Hour Meter, with bezel
8	1335	Switch Plate (no switches or lights)
9	118A	Warning Indicator
14	FP578	Switch, rocker, with cover
15	FP246	Tank, S/S solution, complete
16	425	Gasket for Stainless Steel Tank, 15-1/2"
17	122	Knob, potentiometer
17A	FP200B	Potentiometer with Cable
18	80	Filter, pump inlet, S/S, 50 mesh
19	FP143	Probe, solvent sensor
20	19	Screw, twist-lock
21	450	Twist-lock
21A	123	Switch, reed, vacuum float
22	424	Handle, lift, black
23	431	Vacuum Chamber
24	ULT-RED	Body, red
25	928	Louver (includes screws)
26	45	Quick Disconnect, 1/4 m.p.t.
27	410	Guard, fan
27A	1496	Screws (Fan) 6/32" X 2"-1/4"
27B	16	Nut, nylon
28	412	Fan, cooling
29	459	Louver, 2-1/2" (includes screws)
30	426	Pump Cover, S/S
31	FP197A	Pump Head w/fittings
32	107	Compression Nut, 1/4"
32A	106	Compression Nut, 5/16"
33	FP151	Tubing, pump to tank with fittings (1/4" I.D.)
33A	FP149	Tubing, pump to heater with fittings (1/4" I.D.)
33B	FP150	Tubing, pump to tank with fittings (5/16" I.D.)
34	104	Elbow, 1/8" X 5/16", hose, f.p.t.
34A	100	Elbow, 1/8" X 1/4", hose, m.p.t.
34B	104	Elbow, 1/8" X 5/16", hose, f.p.t.
35	FP148	Pump, complete (120V)
36	435B	Slide Bracket, male
37	435	Slide Bracket, female
38	156	Hose Clamp, 2-1/4"
39	FP163	Exhaust Hose, 2" X 13.5", rubber
40	408	Vacuum Motor, 2-Stage
41	FP137	Castor Plate, complete
42	8	Nut, 1/4-20

ITEM PART # DESCRIPTION

43	413	Circuit Board, heat control
44	429	Heat Sink Plate
45	86	Grommet
46	440	Flange, exhaust
47	FP487	Filter, exhaust, 4"
48	419	Gasket, vacuum motor
49	447	Circuit Board, solvent sensor
50	409A	Relay, vacuum
51	138	Bolt, Hex, 1/4" X 1-1/4"
52	FP138	Heat Exchanger, complete
53	455	Heat Exchanger Mount
53A	76A	Hose Clamp, 2 3/4"
54	101	Coupling, 1/8 m.p.t.
55	103	Elbow, 1/8 m.p.t.
56	105	Nipple, reducer 1/4" X 1/8 p.t.
57	115	Washer, fiber
58	116A	Washer, fiber
59	418	Castor
60	29	Screw, 1/4-20 x 1/2"
61	184	Cord Retainer
62	495A	Power Cord, 25', yellow

MISCELLANEOUS PARTS/KITS

FP144	Syphon plug
FP156	Exhaust hose, 10 ft
FP247	Heat repair kit

**THE ULTIMATE®: PB111
EXTRACTOR
120V**

NOTES:

