



Owner's Manual 19400
Title: Oasis Ozone Generator
Serial Number: _____



The ServiceMaster Company
860 Ridge Lake Blvd.
Memphis, TN 38120
800-765-5656 (Tech Support)

ServiceMaster® Manual
Copyright 2004 by
ServiceMaster Clean
All rights reserved

OASIS OZONE GENERATOR

INFORMATION & OPERATING INSTRUCTIONS

READ ALL INSTRUCTIONS BEFORE OPERATING

OZONE IS A POWERFUL OXIDIZER AND MUST BE USED WITH CARE

WARNING: USE IN UNINHABITED AREAS ONLY. CONSULT MSDS SHEET BEFORE USE. Ozone attacks mucous membranes. Limited exposure can cause irritation to eyes, throat, and nose and may cause nausea. **Do not re-inhabit a treated area until it has been ventilated.** Prolonged exposure can also affect certain organic materials such as rubber, plastic, wire insulation.
Do not get the machine wet.

INSPECTION:

Carefully unpack and inspect the OASIS PLUS for shipping damage. Each unit is tested and inspected before shipment. Any damage incurred is the responsibility of the carrier, who should be notified immediately.

All cleaning and maintenance work should be completed before using the Ozone machine. Ozone treatment should be the final step in room maintenance.

NOTE: the air flowing into the machine must be clean and dry.

NOTE: if the air intake filter is dirty or missing, warranty is voided (see Figure 1).

OPERATION:

NOTE: Ozone is a toxic gas. Follow all safety precautions.

1. Make certain all people, pets, and plants are out of area.
Close all windows and doors.
2. Make sure the filter is installed and is clean.

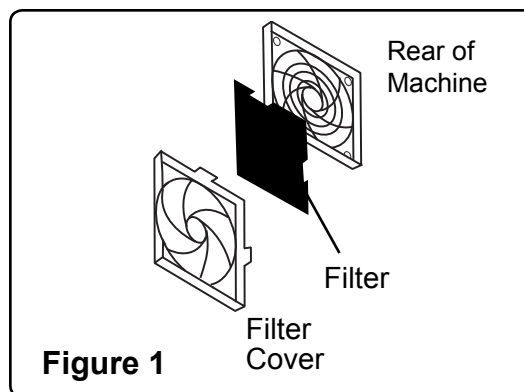

3. Place the Ozone generator on a shelf or tabletop, as high as possible in the area to be treated.
4. Plug the power cord into a grounded, 3-prong outlet.

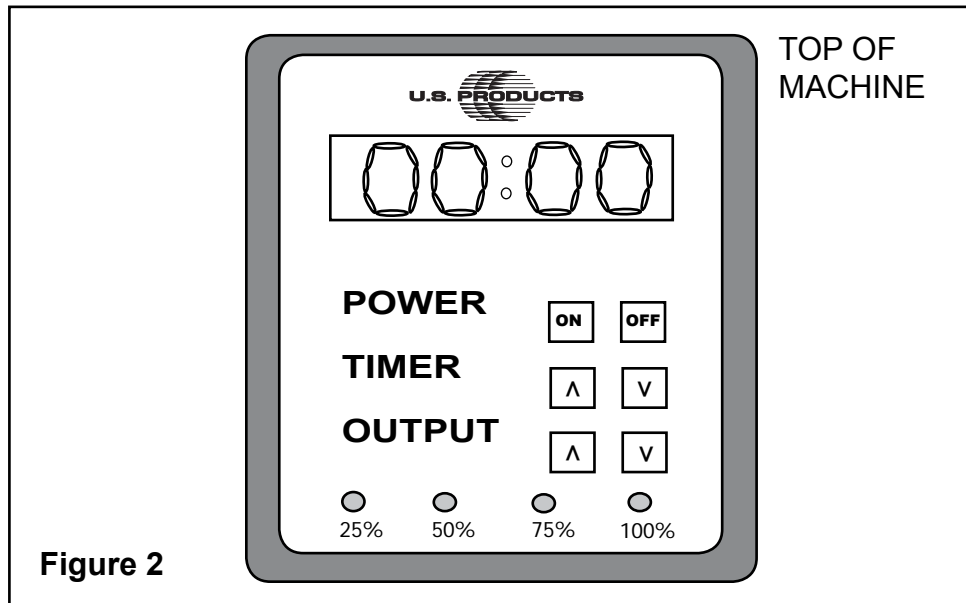

5. Refer to Figure 2, above.

Set the timer to the desired length of time: momentarily pressing the ^ (UP) timer button for one second will increase the time setting by one minute.. Hold the button for 1 -3 seconds to change the time value by two minutes per second. Hold the button for longer than 3 seconds and the time setting will change the time in 20 minute increments.

The maximum time setting is 29:59 hours. After reaching the maximum time, the timer will wrap back to 00:00 and then continue increasing. When the time is being decreased and reaches 00:00, it will wrap to 29:59 and continue decreasing.

6. Select the desired power level by pushing the ^ or v buttons, located to the right of the word "OUTPUT", until the red light is on above 25%; 50%; 75% or 100%. **NOTE:** the machine always defaults to 100% when you plug it in.

When the output level is set to 100%, the machine makes ozone continuously until the timer runs out or the OFF button is pressed. At other power level settings, the machine will produce ozone for the fraction of a minute of the set output level. For example, if the output level is set to 75%, the machine will produce ozone for 75% (45 seconds) of each minute. At 50%, ozone is generated for half of (30 seconds) of each minute, and at 25%, the ozone generation lasts for 15 seconds of each minute. On any setting other than 100%, the ozone generator will be cycling the ozone ON and OFF.

7. Turn the unit on by pressing the ON button, after you have set the time and the output level. Leave the area.
8. When treatment is complete, unplug the ozone machine and ventilate the area completely until all smell of ozone is gone. Do NOT allow people, pets or plants back into the area until the area has been ventilated and all smell of ozone is dissipated.

TIME GUIDELINES:

This Oasis Plus unit will control biological contamination and odor in areas up to 40,000 FT³. Use the following times as a guideline.

Hotel/Motel Room:	20 -- 60 Minutes
Automobiles:	20 -- 30 Minutes
Fire & Flood Restoration:	12 -- 72 Hours

For Automobiles:

See Figure 3 and Figure 4 below.

1. Install the hose over the electrode chamber. Secure the hose with the hose clamp.
2. Set the ozone unit on top of the car, on a cart, or on a table next to the car.
3. Install the foam block into a partially open car window, and insert the hose into the hole in the foam.
4. Set the desired time and output level.
5. Turn the ozone machine ON.

When treatment is complete, ventilate the car completely. Repeat treatment if necessary.

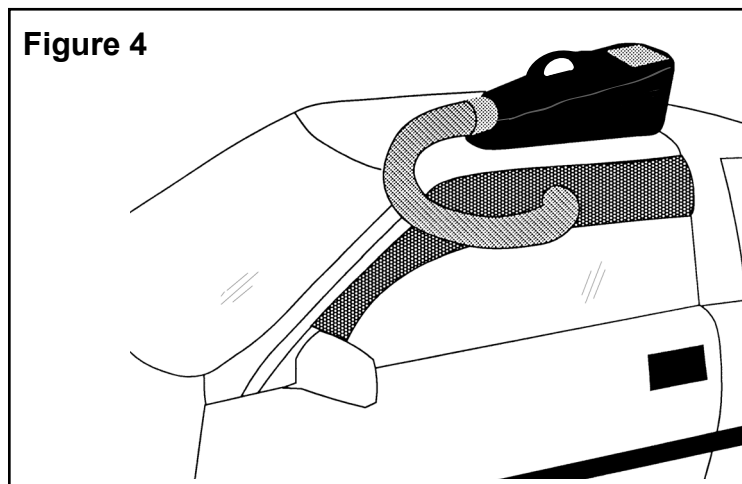
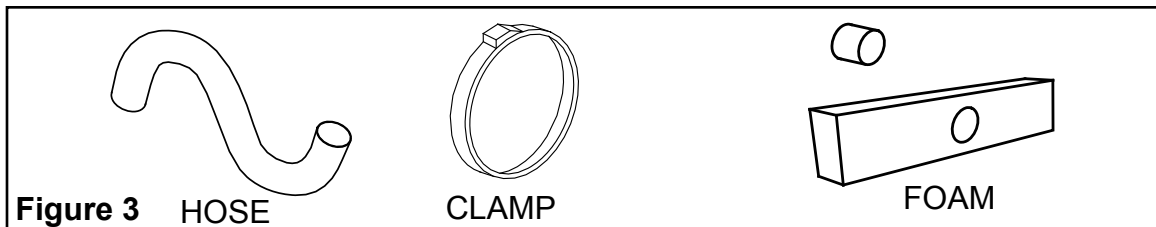

NOTE: Ozone destroys odor causing molecules, thus eliminating the source of the odor. The length of time this process takes will vary depending on the amount of contaminants the ozone has to work on, the amount of area being treated, temperature and humidity, the amount and type of furniture in the area, etc.

NOTE: the process can produce a haze in the treatment area.

OZONE ACTUALLY SEEKS OUT AND DESTROYS THE BACTERIA AND MOLECULES THAT CAUSE ODORS

Not a simple coverup or ionizer, the OASIS Ozone generator is an economical environmental odor neutralizer that actually destroys the source of the odor and leaves pure, fresh oxygen in its place.

This large capacity ozone generator is ideal for commercial use. It is excellent for removing odors from smoke damage, mold, mildew, pet and other sources commonly encountered in building maintenance and refurbishing.

The OASIS ozone generator will eliminate odor in any indoor location, including basements, kitchens, bathrooms, and more. It also provides rapid deodorizing of hotel/motel rooms, meeting rooms, and used cars, boats and RVs.

NOTE:

Ozone treatment is not a substitute for cleaning and source removal.

Ozone treatment should be the final step in cleaning or restoration.

FEATURES AND SPECIFICATIONS

- DESTROYS THE SOURCE OF THE ODOR: not just a cover-up or ionizer
- REMOVES ODORS caused by smoke, pets, mold, mildew, etc.
- 30 HOUR DIGITAL TIMER/PROGRAMMER
- VARIABLE OZONE OUTPUT SETTINGS
- HIGH DENSITY ceramic and stainless steel electrodes (patented)
- POWER SUPPLY OVERLOAD PROTECTION
- OUTPUT: 6.6 ppm or 2.2 gr/hr
- RUGGED CONSTRUCTION: Rotational molded hexane co-polymer body (lifetime warranty)
- DIMENSIONS: 8"H X 8"W X 22"L
- WEIGHT: 12-1/2 lb
- No plates or UV tubes to maintain
- WARRANTY: 3 year with LIFETIME WARRANTY on the ozone electrodes (patented)

Ozone Generator 120V

TROUBLESHOOTING COMMON PROBLEMS



CAUTION: always unplug the machine when removing/adding wiring connections.

<i>IF THIS</i>	<i>CHECK THIS</i>
Timer Resets to 00:00	<p>Make sure the ozone machine is not plugged into an outlet on the same circuit as a machine on which a generator, refrigerator, or heater is also connected. The start-up of a power drawing component can cause a momentary loss of power to all else on the circuit, and that can reset the timer on the ozone machine.</p> <p>Try connecting the power cord to another outlet in another part of the room or the building.</p>
The smell of ozone remains long after the machine has stopped running.	<p>When Ozone has organic molecules to work on, it is destroyed along with the molecule it destroys. If there are a lot of malodorous organic molecules in the treatment area, most of the ozone atoms will be 'used' in the deodorizing process; however, if many more ozone atoms are introduced into the area than can be used to destroy the smell producing molecules, they will be left to revert back to oxygen, and this can take hours.</p> <p>Always try the shortest treatment time that you believe will take care of the job. You will very quickly become adept at estimating the time needed to remove odors in different situations.</p>
No Ozone output	<p>Is the fan running? If the fan is not running, the ozone will not be pushed out in a stream of air.</p> <p>Has the 0.5 amp circuit breaker on the bottom of the machine tripped? Reset the breaker and try the machine again.</p> <p>If the circuit breaker keeps tripping, stop using the machine and call your distributor to make arrangements to have your machine repaired.</p> <p>Do you notice any unusual noises coming from the machine? An arcing sound -- louder than the sound of ozone production -- indicates an internal short in the wiring or an electrode. Call the distributor from whom you purchased the machine to make arrangements to get your machine repaired.</p>



If you are unable to make a diagnosis using this chart, contact the distributor from whom you purchased your machine.

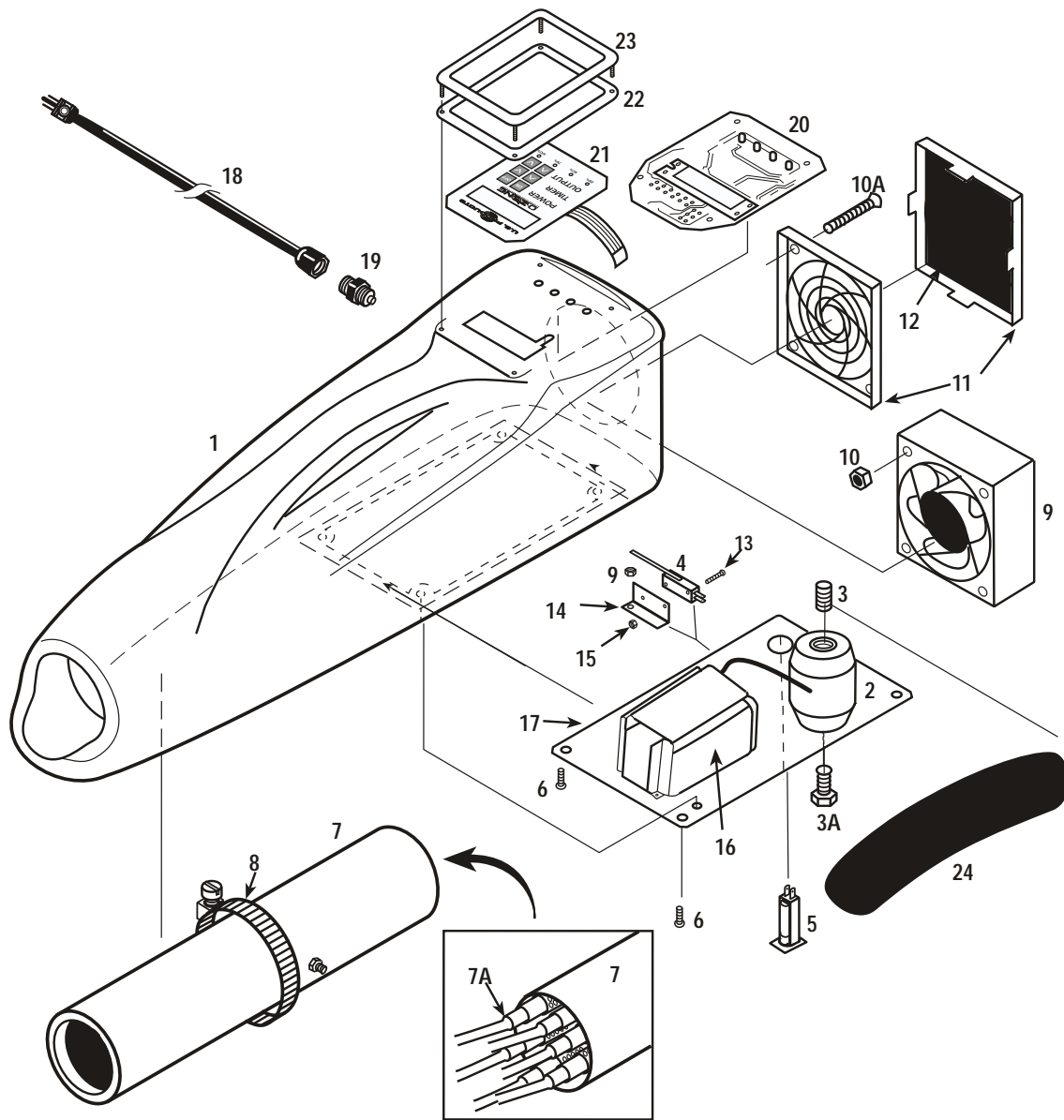

Item	Ref. No.	Qty	Description	Item	Ref. No.	Qty	Description
1#	SUBOZ-TEAL	1	Body Ozone Black	13#	328	2	Screw 4-40 X 5/8 M.S. S/S Pa
2#	OZ-10	1	Terminal Block High Voltage	14#	OZ-22	1	Bracket For Ozone Safety Switch
3A#	326	1	Bolt 3/8 X 1/2 Hex S/S Full	15#	18	6	Nut Nylon Lock 4-40 Stainless
3#	327	1	Stud 3/8 X 1-1/4 S/S	16#	SUBOZ-4PTI-1	1	Transformer 120v. High Voltage
4#	OZ-8	1	Switch Safety For Ozone	17#	OZ-18AC	1	Mounting Plate Bottom Panel Oz
5#	OZ-5	1	Circuit Breaker .5a For Eon-	18#	OZ-11	1	Power Cord 16/3 SjtW 8 Bl
6#	364	5	Bolt 10-32 X 1/2 Ph Phl S/S M	19#	230	1	Retainer Power Cord Water Tight
7#	FP242	1	Ozone Electrode Chamber	[]#	230A	1	Lock Nut Nylon For Cord Retainer
7A#	FP241	6	Ozone Electrode 1 Ea. Long	20#	56381735	1	Pcb Assy-Ozone Gen 120v
8#	198	1	Hose Clamp 48 3-1/2dia 9	21#	OZ-20A	1	Membrane For Ozone Blank
9#	2014	1	Fan 4 100cfm 120 Volt Equip	22#	OZ-16A	1	Gasket Ozone Bezel11/16 Epdm
10#	324	4	Nut Keps 8-32 S/S	23#	OZ-16	1	Bezel For Control Panel Display
10A#	323	4	Screw 8/32 X 2 1/2s/S Flat	24#	OZ-23E	2	Label-ServiceMaster Oasis
11#	2015A	1	Fan Cover & Filter Assy	[]#	56380998	1	Decal-Oasis Ozone Warning
12#	2015B	1	Filter S/S Screen 100 Mesh				

[] = Not Shown

= Revised or new since last update

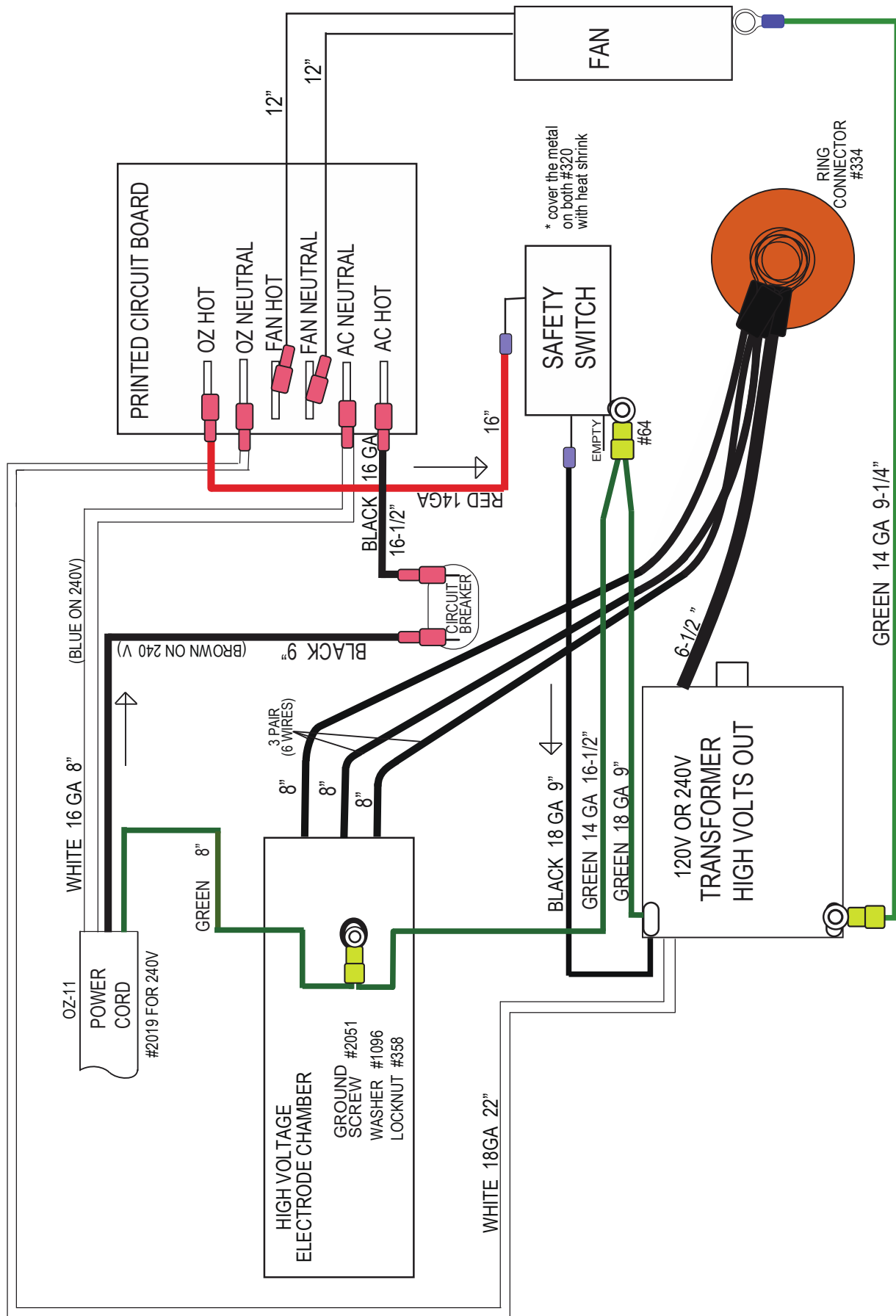



#19400
Oasis Ozone Generator

NOTES:

**The ServiceMaster Company
860 Ridge Lake Blvd.
Memphis, TN 38120
800-756-5656 (Tech Support)**