

HYDRO-ZONE PLUS 120V OASIS-BP-PLUS

INFORMATION & OPERATING INSTRUCTIONS

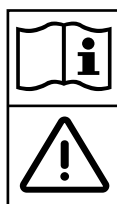
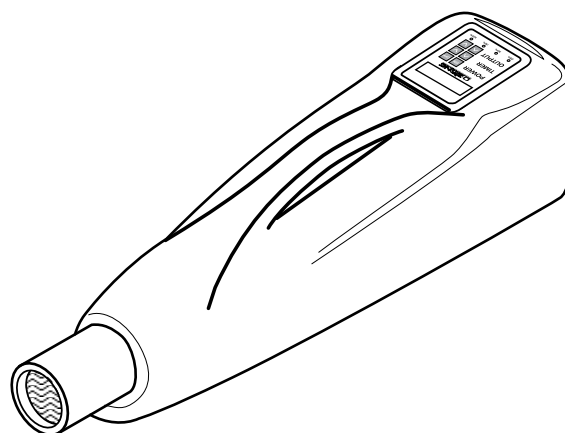

READ ALL INSTRUCTIONS BEFORE OPERATING

OZONE IS A POWERFUL OXIDIZER AND MUST BE USED WITH CARE

WARNING: USE IN UNINHABITED AREAS ONLY.

CONSULT MSDS SHEET BEFORE USE.

Ozone attacks organic matter. Limited exposure can cause irritation to eyes, throat, and nose, and it may cause nausea. **Do not re-inhabit a treated area until it has been well ventilated.** Prolonged exposure can also affect certain organic materials such as rubber, plastic, wire insulation. Do not get the machine wet.

Record the serial number and model of your new Hydro-Zone here: (and be sure to mail your warranty card)

Serial Number: _____ Model: HYDRO-ZONE

Purchase Date: _____

Write the name and phone number of your distributor: _____

IMPORTANT SAFETY INSTRUCTIONS

This machine is only suitable for commercial use, for example in hotels, schools, hospitals, factories, shops and offices other than normal residential housekeeping purposes.

When using any electrical appliance, basic precautions should always be followed, including the following:

NOTE: Read all instructions before using this machine.

WARNING!

To reduce the risk of fire, electric shock, or injury:

- **USE IN UNINHABITED AREAS ONLY.**
- To avoid electric shock, do not expose to rain or snow. Store, and use, indoors.
- Use only as described in this manual. Use only the manufacturer's recommended attachments.
- Do not use with damaged cord or plug. If the machine is not working as it should, has been dropped, damaged, left outdoors or dropped into water, return it to a service center.
- Do not pull by the cord, use the cord as a handle, close a door on the cord, or pull the cord around sharp edges or corners. Keep the cord away from heated surfaces. To unplug, grasp the plug, not the cord.
- Do not handle the plug, the cord or the machine with wet hands.
- Extension cords must be 12/3 and no longer than 50 feet. Replace the cord or unplug immediately if the ground prong becomes damaged.
- Do not put any object into openings. Do not use with any opening blocked; keep free of dust, lint, hair, and anything that may reduce air flow.
- Connect to a properly grounded outlet only.

WARNING!

The Products sold with this Manual contain or may contain chemicals that are known to certain governments (such as the State of California, as identified in its Proposition 65 Regulatory Warning Law) to cause cancer, birth defects or other reproductive harm. In certain locations (including the State of California) purchasers of these Products that place them in service at an employment job site or a publicly accessible space are required by regulation to make certain notices, warnings or disclosures regarding the chemicals that are or may be contained in the Products at or about such work sites. It is the purchaser's responsibility to know the content of, and to comply with, any laws and regulations relating to the use of these Products in such environments. The Manufacturer disclaims any responsibility to advise purchasers of any specific requirements that may be applicable to the use of the Products in such environments.

INSPECTION:

Carefully unpack and inspect the Hydro-Zone for shipping damage. Each unit is tested and inspected before shipment. Any damage incurred is the responsibility of the carrier, who should be notified immediately.

All cleaning and maintenance work should be completed before using the Ozone machine.

Ozone treatment should be the final step in room maintenance.

NOTE: the air flowing into the machine must be clean and dry.

NOTE: if the air intake filter is dirty or missing warranty is voided.

OPERATION:

NOTE: OZONE IS A TOXIC GAS. FOLLOW ALL SAFETY PRECAUTIONS.

1. Make certain all people, pets, and plants are out of area. Close all windows and doors.
2. Make sure the filter in front of the cooling fan is installed and is clean.
3. Place the Oasis Plus unit on a shelf or tabletop as high as possible in the area to be treated.
4. Plug the power cord into a grounded, 3-prong outlet.
5. Set the timer to the desired length of time. Momentarily pressing the UP timer button for one second will increase the time setting by one minute at a time. Hold the button for 1 -3 seconds to change the time value by two minutes per second. Hold the button for longer than 3 seconds and the time setting will change in 20 minutes increments. The maximum time setting is 29:59 hours. After reaching the maximum time, the timer will wrap back to 00:00 and then continue increasing. When the time is being decreased and reaches 00:00, it will wrap to 29:59 and continue decreasing.
6. Select the desired power level: 25%; 50%; 75% 100%. The Oasis Plus always defaults to 100% when you plug it in. When the output level is set to 100%, the machine makes ozone continuously until the timer runs out or the OFF button is pressed. At other power level settings, the machine will produce ozone for the fraction of a minute the level is set at. For example, if the output level is set to 75%, the machine will produce ozone for 75% (45 seconds) of each minute. At 50%, ozone is generated for 30 seconds of each minute, and at 25%, the ozone generation lasts for 15 seconds of each minute. On any setting other than 100%, the ozone generator will be cycling the ozone ON and OFF.
7. Turn the unit on by pressing the ON button. Leave the area immediately.
8. When treatment is complete, unplug the ozone machine and ventilate the area completely until all smell of ozone is gone. Do NOT allow people, pets, or plants back into the area until all smell of ozone has dissipated.

TIME GUIDELINES:

This Oasis Plus unit will control biological contamination and odor in areas up to 40,000 FT³.

Use the following times as a guideline.

Hotel/Motel Room:	20 -- 60 Minutes
Automobiles:	20 -- 30 Minutes
Fire & Flood Restoration:	12 -- 72 Hours.

For Automobiles:

Refer to Figure 1 and Figure 2 below

1. Install the hose onto the electrode chamber. Secure the hose with the hose clamp.
2. Set the Ozone Plus on top of the car or on a cart or table next to the car.
3. Install the foam block into a partially closed car window, and insert the hose through the hole in the foam.
4. Set the time and the output level.
5. Turn the ozone machine ON.

When treatment is complete, ventilate the car completely. Repeat treatment if necessary.

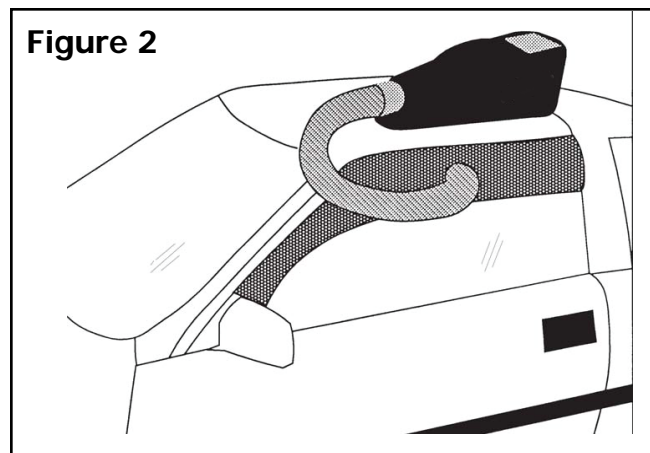
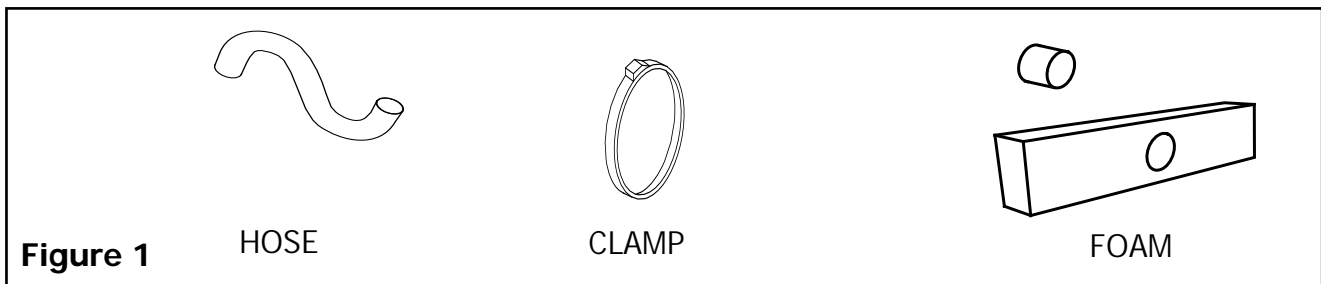

NOTE: Ozone destroys odor causing molecules, thus eliminating the source of the odor. The length of time this process takes will vary depending on the amount of contaminants the ozone has to work on, the amount of area being treated, temperature and humidity, the amount and type of furniture in the area, etc.

NOTE: the process can produce a haze in the treatment area.

TROUBLE SHOOTING:

CAUTION:  **ALWAYS UNPLUG THE MACHINE BEFORE YOU DO ANY INTERNAL TROUBLESHOOTING**

IF THIS OCCURS

CHECK THIS

NO POWER	Look at the power cord, to make sure it is plugged in. Check the outlet, to make sure it has power in it. Look at the circuit breaker on the bottom of the machine, to make sure it has not tripped. Check the internal safety switch to make sure it is 'activated' when the bottom cover is on.
TIMER DOES NOT WORK	The digital display has segments missing from some numbers. The timer \wedge or \vee buttons do not change the time display. The time display does not change as time passes.
THE % of OZONE DOES	The % button does not work. The amount of ozone output does not change. The % button does work, but one (or more) of the red LEDs is not lighting.

NOTE: if the air intake filter is dirty or missing warranty is voided.

SPECIFICATIONS and FEATURES:

Output volume: Variable

Maximum Output: 2.2 gm/HR; 6.6 ppm

Timer: Digital, 00:00 to 29:59 hours

Production Method: Patented, high-density and stainless steel electrodes

Air Flow: 100 CFM

Deminsions: 8"H X 8"W X 22"L

Weight: 12-1/2 lbs

Warranty: 3 year; lifetime on electrodes *

- **Rugged construction means reliability**
- **No maintenance of plates or UV tubes**
- **Over-load protection**

* A dirty or missing filter at the air intake voids the warranty

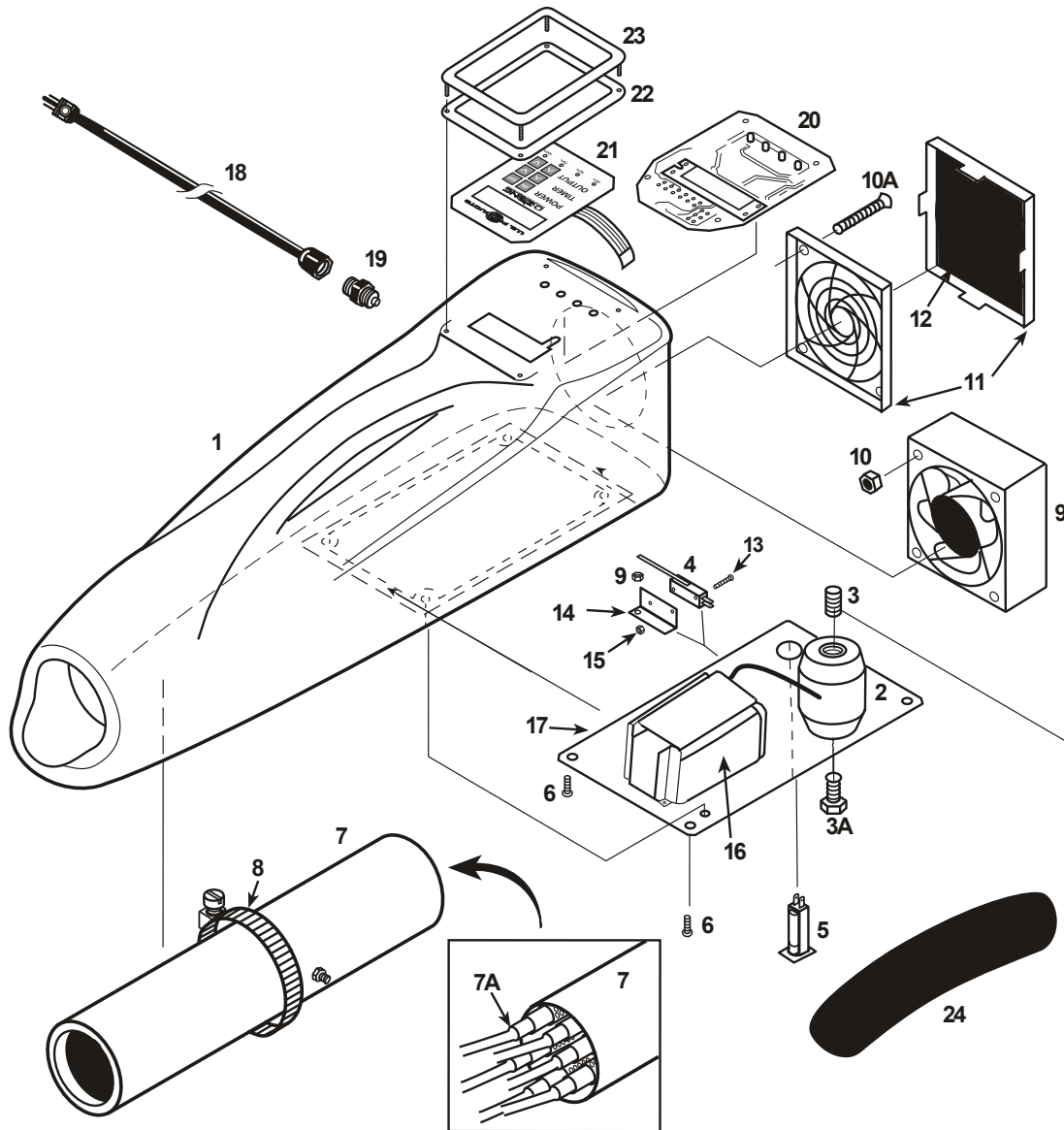

Item	Ref. No.	Qty	Description	Item	Ref. No.	Qty	Description
1#	SUBOZ-BLK	1	Body Ozone Black	13#	328	2	Screw 4-40 X 5/8 M.S. S/S Pa
2#	OZ-10	1	Terminal Block High Voltage	14#	OZ-22	1	Bracket For Ozone Safety Switch
3A#	326	1	Bolt 3/8 X 1/2 Hex S/S Full	15#	18	6	Nut Nylon Lock 4-40 Stainless
3#	327	1	Stud 3/8 X 1-1/4 S/S	16#	SUBOZ-4PTI-1	1	Transformer 120v. High Voltage
4#	OZ-8	1	Switch Safety For Ozone	17#	OZ-18AC	1	Mounting Plate Bottom Panel Oz
5#	OZ-5	1	Circuit Breaker .5a For Eon-	18#	OZ-11	1	Power Cord 16/3 SjtW 8 Bl
6#	364	5	Bolt 10-32 X 1/2 Ph Phi S/S M	19#	230	1	Retainer Power Cord Water Tight
7#	FP242	1	Ozone Electrode Chamber	[]#	230A	1	Lock Nut Nylon For Cord Retainer
7A#	FP241	6	Ozone Electrode 1 Ea. Long	20#	56381735	1	Pcb Assy-Ozone Gen 120v
8#	198	1	Hose Clamp 48 3-1/2dia 9	21#	OZ-20A	1	Membrane For Ozone Blank
9#	2014	1	Fan 4 100cfm 120 Volt Equip	22#	OZ-16A	1	Gasket Ozone Bezel1/16 Epdm
10#	324	4	Nut Keps 8-32 S/S	23#	OZ-16	1	Bezel For Control Panel Display
10A#	323	4	Screw 8/32 X 2 1/2s/S Flat	24#	OZ-23A	2	Label Ozone Hydroforce Curve
11#	2015A	1	Fan Cover & Filter Assy	[]#	56380998	1	Decal-Oasis Ozone Warning
12#	2015B	1	Filter S/S Screen 100 Mesh				

[] = Not Shown
 # = Revised or new since last update

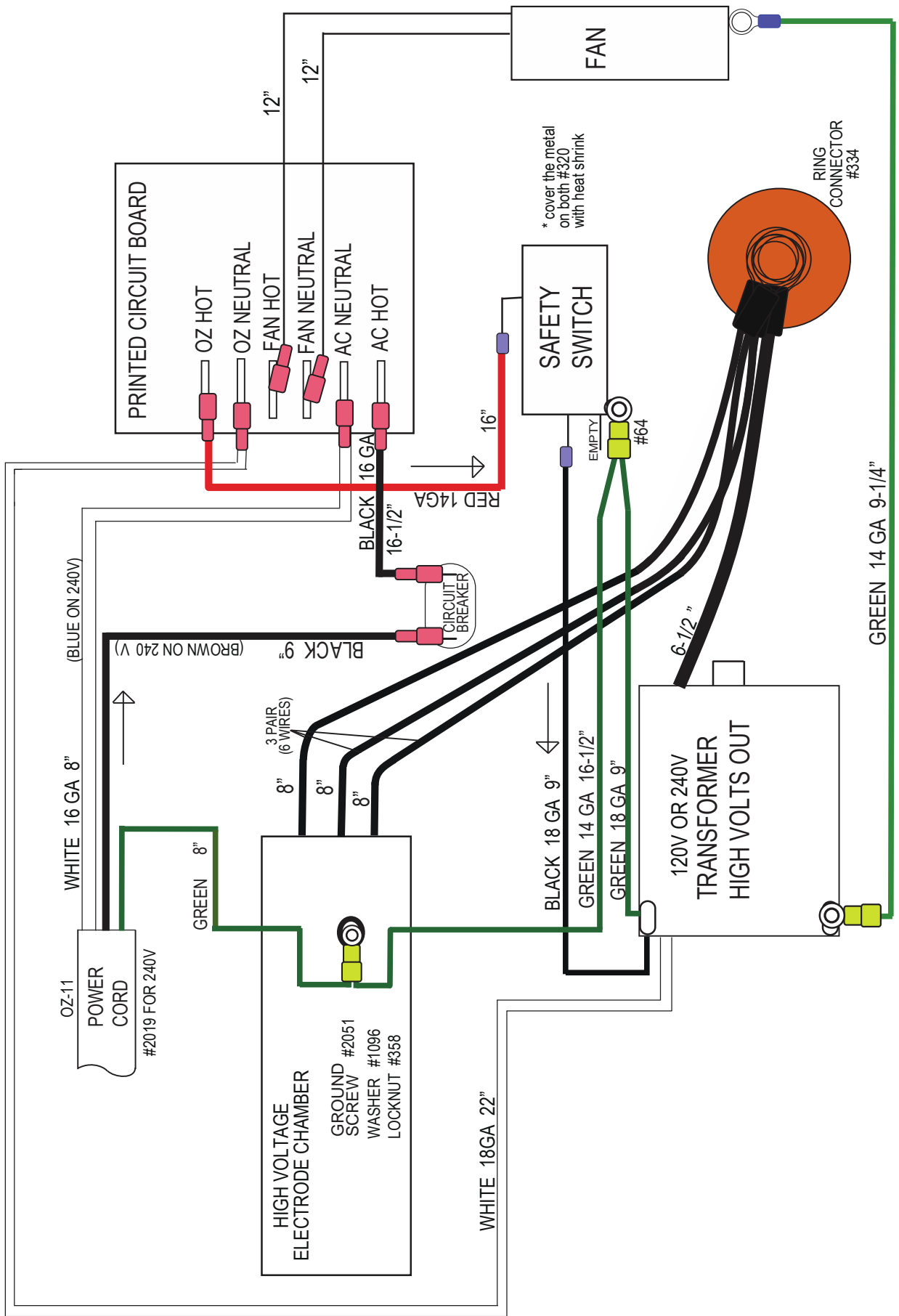

HYDRO-FORCE™

4282 South 590 West
Salt Lake City, Utah 84123

Phone: 800-948-1779
Local: 801-207-1382