

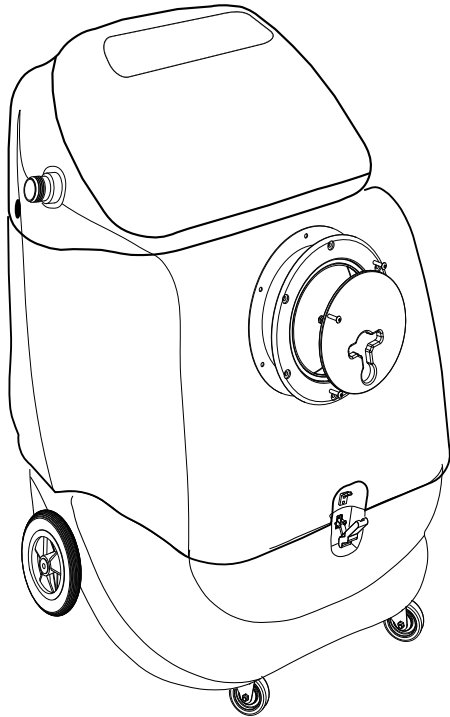

# FLOOD KING<sup>®</sup>

## 240V



### INFORMATION & OPERATING INSTRUCTIONS



**CAUTION: DO NOT OPERATE MACHINE UNTIL YOU HAVE READ ALL SECTIONS OF THIS INSTRUCTION MANUAL**



#### IMPROPER USE OF THE MACHINE WILL VOID THE WARRANTY

1. Always use a defoamer when foaming occurs to prevent vacuum motor damage.
2. Keep machine from rain and snow, extremes in temperatures, and store in a heated location. Use the machine indoors. Do not use outdoors.
3. Never use the machine without the pre-filter bag installed.

## IMPORTANT SAFETY INSTRUCTIONS

This machine is only suitable for commercial use, for example in hotels, schools, hospitals, factories, shops and offices other than normal residential housekeeping purposes.

When using any electrical appliance, basic precautions should always be followed, including the following:

**NOTE:** Read all instructions before using this machine.

### **WARNING!**

To reduce the risk of fire, electric shock, or injury:

- Do not leave the machine unattended when it is plugged in. Unplug the unit from the outlet when not in use and before servicing.
- To avoid electric shock, do not expose to rain or snow. Store, and use, indoors.
- Do not allow to be used as a toy. Close attention is necessary when used near children.
- Use only as described in this manual. Use only the manufacturer's recommended attachments.
- Do not use with damaged cord or plug. If the machine is not working as it should, has been dropped, damaged, left outdoors or dropped into water, return it to a service center.
- Protect the cord. Do not: use the cord as a handle, close a door on the cord, or pull the cord around sharp edges or corners. Do not run the machine over the cord. Keep the cord away from heated surfaces. To unplug, grasp the plug, not the cord.
- Do not handle the plug, the cord or the machine with wet hands.
- Extension cords must be 12/3 and no longer than 50 feet. Replace the cord or unplug immediately if the ground prong becomes damaged.
- Do not put any object into openings. Do not use with any opening blocked; keep free of dust, lint, hair, and anything that may reduce air flow.
- Keep loose clothing, hair, fingers, and all parts of body away from openings and moving parts.
- Do not pick up anything that is burning or smoking, such as cigarettes, matches, or hot ashes, or any health endangering dusts. Do not use to pick up flammable or combustible liquids such as gasoline or use in areas where they may be present.
- Turn off all controls before unplugging.
- Connect to a properly grounded outlet only.

## **INSPECTION:**

Carefully unpack and inspect your FLOOD KING for shipping damage. Each machine is tested and inspected before shipping. Any damage incurred during shipping is the responsibility of the carrier. You should notify the carrier immediately if you notice damage to the box or to the machine or parts.

## **MAINTENANCE:**

Prior to each job, inspect the recovery tank pre-filters, the stainless steel in-line filters, the float, and the drain hose to make sure every thing is clean and able to function properly. After each job, remove and clean both the nylon mesh pre-strainer at the vacuum inlet and the stainless steel filters in the bottom of the recovery tank. Unscrew the clear caps off the in-line filters (located under the recovery tank) and clean the screens often. Pump damage may occur if the filters become clogged.

**⚠** Check hose clamps regularly to make sure they are tight. The pump discharges water at high pressure. If a hose clamp becomes loose, the hose could also come loose, or fall off of the hose barb, and leak water into the base compartment.

Lubricate the wheels, castors, latches, and quick disconnects with an all purpose silicone spray. The vacuums and the pumps do not require any scheduled maintenance; however the vacuum motors may require new brushes after 1000 - 1500 hours. Clean the body with an all purpose detergent, and protect it with an automobile interior spray protectant.

**Record the serial number and model of your new flood extractor here:**

**Serial Number:** \_\_\_\_\_ **Model:** FLOOD KING-240

**Purchase Date:** \_\_\_\_\_

**Write the name and phone number of your distributor:**

---

---

**be sure to register your purchase to activate your warranty**

**SAVE THESE INSTRUCTIONS**

## SET-UP:

Connect the vacuum/recovery hose to the vacuum inlet hose barb on the recovery tank. Connect the dump hose to the hose fitting on the rear of the machine. Check filters. Put the lid on the recovery tank. Plug the machine into a grounded outlet.

## VACUUM OPERATION:

A switch is provided for each vacuum motor. The machine can operate with either one, or both, vacuum motors running.

## VACUUM SHUT-OFF:

When the recovery tank is full, the float system will shut off power to the vacuum motor(s) to prevent water from entering the motor(s). The float may not work properly if it is extremely dirty or if there is foam in the tank. Use a defoamer any time foam is present. Once the tank has emptied sufficiently, the vacuums will come back on automatically.

## PUMP OPERATION:

Always be sure to uncap the pump-out fitting and connect the dump hose before turning the pumps on. Failure to do so may result in blown hoses or loose fittings; water will damage motors and switches. The two diaphragm pumps on your Flood King work together. When you turn the pump switch on, both pumps will run, and they will continue to run until you turn them off. Do not let the pumps run dry for extended periods of time.

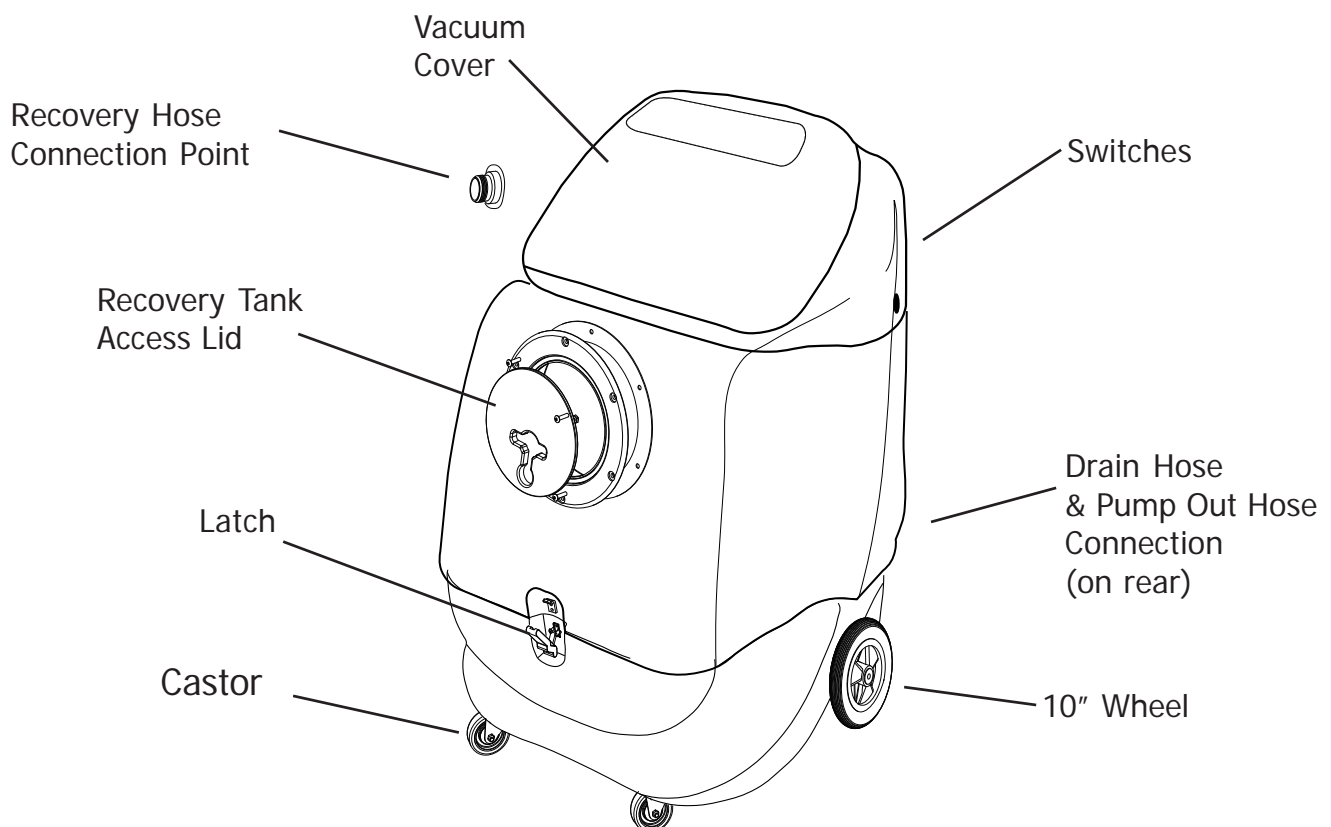

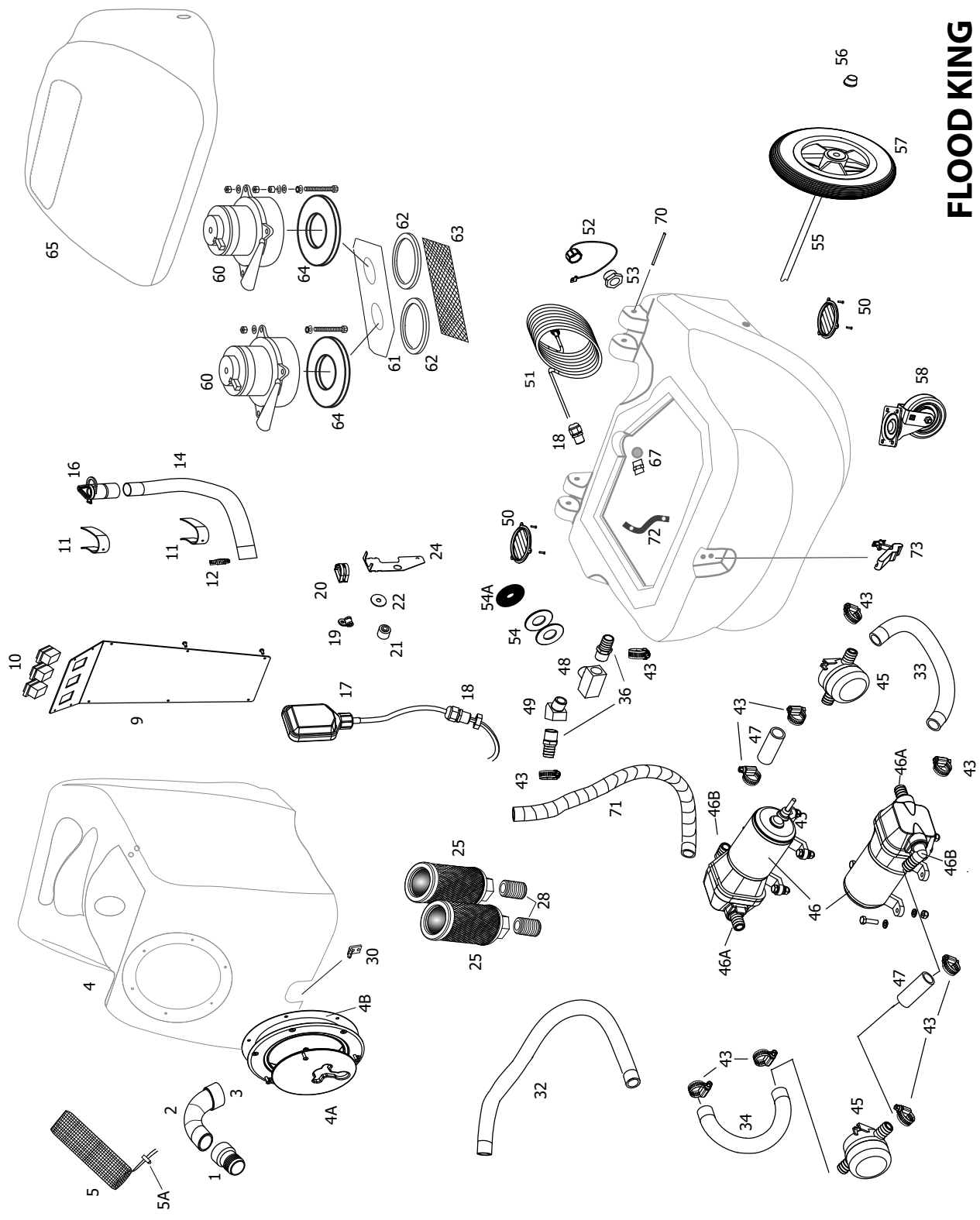

# FLOOD KING 240V

# FLOOD KING

## PART LIST

240V

<u>Item</u>	<u>Part No</u>	<u>Description</u>	<u>Item</u>	<u>Part No</u>	<u>Description</u>
1	2077	Hose Barb, 3.8	46B	1466	Hose barb/elbow
2	1463	Eblow, ABS, 45 degrees (3)	47	1468	Hose, 1.9 cm X 7.6 cm
3	1464	Bushing, 5 cm slip	48	152	"T" brass
4	SUBVT-25	Tank, recovery	49	372	Elbow, brass, 45 degree
4A	2070B	Lid, and ring, 15.25 cm	50	928	Louver, 3", includes screws
4B	1129	Gasket, for vacuum lid	51	2019	Power cord, 7.5 m
5	FP521	Strainer bag, vac inlet	52	237	Cap, with chain
9	1434	Switch plate	53	379	Hose fitting
10	FP578	Switch, SPST	54	152A	Washer, flat, S/S
11	1130	Strap, velcro	54A	237A	Washer, rubber
12	1518	Hose Clamp	55	910-24-50	Axle, 62.23 cm long
14	1060B	Hose, drain	56	27A	Axle cap
16	1060C	Plug, drain hose	57	2084	Wheel, 25.4cm
17	2068	Float, switch	58	905	Castor. 10 cm
18	230	Retainer, cord	59	SUBBS-13	Base, black
19	196	Clamp, cable	60	408D	Vacuum motor, 3-stage
20	1518	Tie wraps, 12.7 cm	61	MA-9	Manifold, vacuum
21	1349	Spacer, float	62	1056	Screen, wire filter, vac inlet
22	290	Washer, flat, rubber	64	1477	Gasket, under vac manifold
24	1350	Bracket, float mounting	65	FP	Cover, over vacuums
25	2069	Filter, inlet, 60 mesh	67	937	Coupling, PVC
28	1168	Nipple, PVC, 1.9 cm X 3.5 cm	70	801	Hinge Pin
32	1468	Hose, 1.9 cm ID X 55.88 cm	71	2079	Hose, reinforced, 25.4 cm
33	1468	Hose, 1.9 cm ID X 35.5 cm	72	1476	Strap, stop, 43 cm
34	1468	Hose, 1.9 cm ID X 33 cm	73	908B	Latch and strike
36	378	Hose barb, brass			
43	380	Hose clamp			
45	2074	Filter, in line, 50 mesh			
46	2067B	Pump, dump			
46A	N/A	Hose barb. from pump			
			<b><u>MISCELLANEOUS PARTS</u></b>		
			919C		Vacuum Inlet Hose
			717		Hose Cuff, for Vac Hose
			956A		Drain Hose, 15 m
			971		Mesh bag, for hoses

## **SPECIFICATIONS:**

<b>POWER CORD:</b>	One, 7.5 m, 12 gauge, 3-wire with hospital grade plug
<b>POWER CONSUMPTION:</b>	13 Amps, total
<b>RECOVERY CAPACITY:</b>	343 liter
<b>VACUUM INTAKE HOSE:</b>	2' X 25'
<b>VACUUM MOTOR(S):</b>	Two 3-stage vacuum motors
<b>WATER LIFT/CFM:</b>	100 inches/170 cfm
<b>AIR WATTS:</b>	520 AW (in operational range)
<b>OVERFLOW PROTECTION:</b>	Electronic Float / Auto ON/OFF
<b>DISCHARGE PUMPS:</b>	Two diaphragm bilge pumps
<b>DISCHARGE HOSE:</b>	One 3/4" X 50'
<b>DISCHARGE RATE:</b>	10.5 GPM
<b>FILTER SYSTEM:</b>	One 80 micron polyester mesh strainer at the water inlet to the recovery tank  Two 60 mesh S/S filters in recovery tank  Two 50 mesh S/S screens in-line
<b>WEIGHT:</b>	38.5 Kg



425-322-0133 / 800-257-7982 / FAX: 425-322-0136  
11015 - 47th Ave. W. / Mukilteo, WA 98275  
VISIT US AT: <http://www.usproducts.com>