



# Diamond Products GTXR Owner's Guide and Maintenance Logs

---

**HydraMaster**  
11015 47<sup>th</sup> Avenue West  
Mukilteo, Washington 98275

MAN-47151 Rev. B, OCTOBER 2018  
(000-182-739D)

No part of this manual may be reproduced or used in any form or by any means (i.e. graphic, electronic, photocopying or electronic retrieval systems) without the express written permission of HydraMaster. Specifications and information in this document are subject to change without prior notice. All rights reserved. © 2018 HydraMaster

# Introduction

This Owner's Guide provides you with important Contact Information, Warnings and Precautions, a System Operation Overview and Maintenance Logs. In the back inside cover of this guide you will also find a CD that contains the digital Owner's Manual.

## **▲ WARNING**

Read the entire digital Owner's Manual and this Owner's Guide before using this product. Failure to do so can result in serious injury or death.

### **HOW TO USE THESE RESOURCES**

**The Owner's Guide** is to be used for quick reference only and is not intended to be a comprehensive source of information. Refer to the Owner's Manual when more detailed information is needed.

**The Machine Maintenance Log** is located within the Owner's Guide. It is wise to keep the Owner's Guide in a visible location near the truckmount so that the log stays up to date. **Please note that records of maintenance must be kept and copies may be required to be furnished to HydraMaster before any warranty is honored.**

**The digital Owner's Manual** contains information on everything from cleaning and chemicals to truckmount operation and maintenance. It also contains detailed machine assemblies and parts lists as well as a troubleshooting guide. You should become familiar with the material in the Owner's Manual as it contains information that is essential for safe operation and increased truckmount reliability.

This Owner's Guide contains the following sections:

- Contact Information
- Warnings, Cautions and Notices
- Responsibilities
- System Concept
- Machine Specifications
- High Altitude Operation
- Local Water Precautions
- **Operating Instructions**
- **Maintenance Logs**



### CONTACT INFORMATION

If you have any questions regarding the operation, maintenance or repair of this machine, please contact your local distributor.

To find a local distributor, please visit our website at <http://hydramaster.com/HowToBuy/DealerLocator.aspx>

If your question cannot be resolved by your distributor or by the information within this manual, you may contact HydraMaster direct using the following phone numbers.

HOURS	TELEPHONE NUMBERS	E-MAIL ADDRESSES
Monday-Friday 7:00 a.m. to 5:00 p.m. Pacific Time	<b>Technical Support</b> (800) 426-1301 FAX : (800) 426-4225	<b>Technical Support</b> techsupport@hydramaster.com
	<b>Customer Service/Parts</b> (800) 426-1301 FAX : (800) 426-4225	<b>Customer Service/Parts</b> parts@hydramaster.com

When calling your distributor, be sure to reference the serial number and date of purchase.

#### FOR YOUR REFERENCE:

Serial No. \_\_\_\_\_

Date of Purchase: \_\_\_\_\_

Purchased From (Distributor): \_\_\_\_\_

## WARNINGS, CAUTIONS AND NOTICES

### **⚠ WARNING**

HydraMaster uses this WARNING symbol throughout the guide to warn of possible injury or death.

### **CAUTION**

This CAUTION symbol is used to warn of possible equipment damage.

### **NOTICE**

This NOTICE symbol indicates that federal or state regulatory laws may apply, and also emphasizes supplemental information.

# GTXR

## **⚠ WARNING**

During the operation of the truckmount many components are in motion. Never touch any part of the truckmount that is in motion. Serious injury may result.

## **⚠ WARNING**

During the operation of the truckmount many surfaces will become extremely hot. Never touch hot surfaces. Serious injury may result.

## **⚠ WARNING**

The operation of this truckmount can produce noise levels exceeding 85 decibels to a distance of 10 feet. The Occupational Safety and Health Administration (OSHA) recommends the use of hearing protective equipment if a person is exposed to an average of 85 decibels over an eight hour period. Check with local and state agencies concerning hearing conservation rules.

## **⚠ WARNING**

During the operation of the truckmount carbon monoxide and other toxic fumes are produced. Position the vehicle so that any fumes produced will be directed away from inhabited areas and any points of building entry (doors, windows, air conditioning units, fans, etc.). Do not occupy the vehicle while the truckmount is in operation. Serious injury may result.

## **⚠ WARNING**

During the operation of the truckmount chemicals known to the State of California to cause cancer, birth defects and other reproductive harm are produced by the engine exhaust.

## **⚠ WARNING**

Never operate the truckmount with a portable gas container inside the vehicle. Doing so will increase the risk of fire and explosion. Serious injury or death may result.

## **⚠ WARNING**

Transporting a vented fuel container that presently contains, or has ever contained in the past, a flammable liquid is strictly forbidden by HydraMaster and by federal and state regulations. Doing so will increase the risk of fire and explosion. Serious injury or death may result.

## **⚠ WARNING**

Never smoke in or around the truckmount. Doing so will increase the risk of fire and explosion. Serious injury or death may result.

## **CAUTION**

During the operation of the truckmount the exhaust system will become extremely hot. Keep all flammable materials away from the truckmount exhaust system. Failure to do so will increase the risk of fire and explosion. Serious property damage may result.

## **CAUTION**

Never operate the truckmount when the vehicle is tilted more than 10 degrees in any direction. Doing so will result in improper lubrication of the internal components, and will increase the risk serious component or engine damage.

## **CAUTION**

Never perform cleaning operations when the truckmount engine is running at the IDLE throttle position. Failure to do so will increase the risk of serious component or engine damage.

## **CAUTION**

Never operate the truckmount with the vehicle doors closed. Doing so results in extremely high temperatures inside the vehicle and will lead to serious component or engine damage.

## **CAUTION**

Never use concentrated acids or solvents (including d-limonene) in the truckmount water system or chemical system. Use of these products will cause serious component damage.

## **CAUTION**

Never operate the truckmount with a water hardness reading measuring 3.0 grains per gallon or higher. Using reading than 3.0 grains per gallon will cause scale to build up inside the truckmount water system. Scale build up causes serious component damage. Test all water prior to use and use water softening equipment if necessary.

# GTXR

## **CAUTION**

Never allow water to freeze inside the truckmount. Serious component damage will occur. Perform all freeze guarding procedures outlined in the digital Owner's Manual.

## **CAUTION**

Many vehicles have critical components mounted directly below the floor that can easily be damaged. Before drilling holes in the floor of the vehicle, inspect the underside of the vehicle for critical components. Failure to do so may result in damage to the vehicle.

## **CAUTION**

During the operation of this equipment, surfaces will become hot. Do not allow components such as hoses to touch hot surfaces. Failure to heed this warning can result in equipment damage which is not covered by warranty.

## RESPONSIBILITIES

### **The Purchaser's Responsibilities**

Prior to purchasing a van, ensure that the payload is suitable for all of the equipment that will be installed and transported. This includes and is not limited to: the truckmount, recovery tanks, fresh water tanks and on-board water, hose reels, hoses, cleaning tools, chemicals, drying equipment, etc. Payload capacity information is available through the auto dealer, the manufacturer's web site, and is also located on the door pillar of the driver's side door.

Purchase a heavy duty Group 24 (550 CCA or better) battery for this truckmount. This is normally available from the installation dealer.

Prior to dropping your van off at the distributor for the truckmount to be installed, have a spray-on bed liner applied to the floor such as Rhino Lining® or Line-X®.

Prior to operating the truckmount read this manual in its entirety and familiarize yourself with the information contained here. Special attention should be paid to all cautions and warnings.

The distributor is responsible for the correct installation of the truckmount. The distributor is also responsible to train you in the correct and proper operation and maintenance of the truckmount.

### **NOTICE**

Any modification of the truckmount may void the warranty.

### **The Distributor's Responsibility**

#### **Acceptance of Shipment**

Before accepting the truckmount, check the following:

- The truckmount should be free from any damage during shipping. Do not sign the delivery receipt until you have closely inspected the truckmount and noted any damage on the delivery receipt. Hidden damage may be present even if the box looks okay. It is recommended that the box be opened before signing for the shipment.
- Check the packing list and verify that all items are accounted for.





### **Installation Responsibilities**

- Ensure proper payload capacity. It is the distributor's responsibility to verify that the equipment package does not exceed the vehicle capacity.
- Ensure installation of a safe fuel tap system and through-floor fittings as provided by HydraMaster.
- Proper placement of the truckmount, recovery tank, fresh water tank, and accessories in the vehicle and securing them with bolts and back up plates. The distributor should verify that the owner is in agreement with the layout.
- Ensure proper connection of the fuel lines.
- Ensure proper connection and installation of the battery. Verify that the battery is in accordance with HydraMaster's recommendation.
- Check the pump, vacuum blower and engine oil levels prior to starting the truckmount.
- Start and run the truckmount and check that all systems function properly.
- Test all hoses, wands, etc. for correct operation.
- Ensure timely return of the document package.

### **Training**

The distributor should provide a thorough review of the operation manual with the purchaser along with instruction and familiarization in:

- How all the truckmount's systems function.
- All safety precautions and their importance.
- How to correctly start and shut down the truckmount.
- How to correctly clean with the truckmount.
- Where and how often to check and change component oil levels.
- Freezing damage and how to avoid it. This includes explaining proper freeze guarding procedures.
- How to do basic troubleshooting of the truckmount.
- Hard water damage and how to avoid it. This includes how to determine if hard water exists in your area and the installation and use of water softening systems.
- The truckmount's warranty and warranty procedures.

# GTXR

## SYSTEM CONCEPT

The system utilizes an internal combustion engine to provide the power necessary to turn both a vacuum pump and a high pressure water pump.

The heat of the engine and blower exhausts is transferred to the high pressure water in the finned tube heat exchanger of the system.

Finally, the chemical is injected into the pressurized water stream and the heated solution is delivered to the cleaning tool. The solution is recovered by the vacuum generated by the vacuum pump. This solution is collected in the recovery tank for proper disposal.

## MACHINE SPECIFICATIONS

Frame Dimensions	24.0" W x 31" H x 36" D	
Weight	570 lbs.	
Engine- Briggs and Stratton Vanguard 18 HP	Oil Type	Synthetic 5W-30
	Capacity	Approx. 1 1/2 quarts (48 oz.) when changing oil and filter
	Engine rpm	3,150 rpm
	Fuel Consumption	1.0 gph
Ignition	Electric Key Start	
Vacuum Blower- Tuthill 3006 Competitor Plus SL (Dual Splash Lubrication)	Max. Vac.	12" Hg
	Oil Type	PneuLube or other ISO 100 rating
	Gear End Capacity	Approx. 7.0 oz.
	Drive End Capacity	Approx. 5.0 oz.
	Blower rpm	3,150 rpm
Water Pump	Oil Type	30W non-detergent
Electric Clutch	Capacity	Approx. 8.0 oz.
	Pump Rate	3.5 gallons per minute
	Pump rpm	1,750 rpm
Operating Pressure	0 - 1,000 psi	
Chemical System	Stainless Steel Last Step Chemical Injection	
Heating System	Finned Tube Heat Exchanger	

# GTXR

Standard Equipment	High Pressure Hose	1/4" High Temperature Lined/ Vinyl Cover - 100 ft.
	Vacuum Hose	2" Vacuum Hose- 100 ft.
		1-1/2" Wand Whip Line- 10 ft.
	Recovery Tank	70 gallon MaxAir Universal Tank
	Cleaning Wand	Stainless Steel S-bend
		Replaceable Grip
		Rebuildable Solution Valve
	Chemical Jug	5 gallon
	Battery Box	
	Van Decal	
	Van Installation Kit	
	Owner's Manual (on CD)	
	Owner's Guide (paper copy)	
Optional Equipment	Recovery Tank	100 Gallon MaxAir Universal Tank - Single Port
	Fresh Water Tank	70 Gallon Rotomolded Tank
		85 Gallon Rotomolded Tank
	Automatic Wastewater Disposal System	Comet AWDS

## HIGH ALTITUDE OPERATION

Elevation plays a key role in how the truckmount will operate. Operation at high altitude (above 5,000 ft.) may require a high-altitude carburetor jet. Use of this jet at high altitude will improve power, reduce fuel consumption and help reduce excessive carbon build-up in the exhaust and heat exchanger systems.

Contact the local Briggs and Stratton dealer or HydraMaster to obtain the proper jet size. Your local Briggs and Stratton dealer can be located at <http://www.briggsandstratton.com/us/en/support/dealerlocator> .

## LOCAL WATER PRECAUTIONS

The quality of water varies greatly. Many areas have an excess of minerals in the water which results in what is commonly called “hard water.” These minerals tend to adhere to the insides of heater coils and other parts of the machines causing damage and a loss of cleaning effectiveness. This influences the reliability and efficiency of equipment in direct proportion to the level of hardness.

### Hard Water Advisory

HydraMaster recognizes that any hard water deposits which might occur within the water system of our truckmounts is a serious problem. The precision technology of truckmount heat exchanger systems is intolerant of any foreign material. Hard water deposits will ultimately decrease the performance of the system and are expected to seriously lower the reliability of the machine.

To validate a machine’s warranty, HydraMaster requires that all machines operating in designated “Hard Water Areas” (3.0 grains or more per gallon) be fitted with a water softening system, or a properly installed magnetic-type descaler must be used and maintained. Periodic descaling or acid-rinsing alone is not adequate in these areas. HydraMaster does not recommend any particular type or brand; however, the relative effectiveness of some types of magnetic descalers or softeners may require additional periodic use of descaling agents.

HydraMaster also recommends, in the strongest possible terms, that machines in all areas be fitted with a water softening system for improved operation and reliability.

## **CAUTION**

Failure to take appropriate measures to prevent scale build up can result in system failure and loss of warranty on affected parts.

## Hard Water Area Map

The hard water map, shown in Figure 1, defines hard water areas in the continental United States which compromise fluid related components such as hoses, fittings, heaters, pumps, valves and water-cooled engines. For other countries, hard water area maps can be obtained from geological societies.

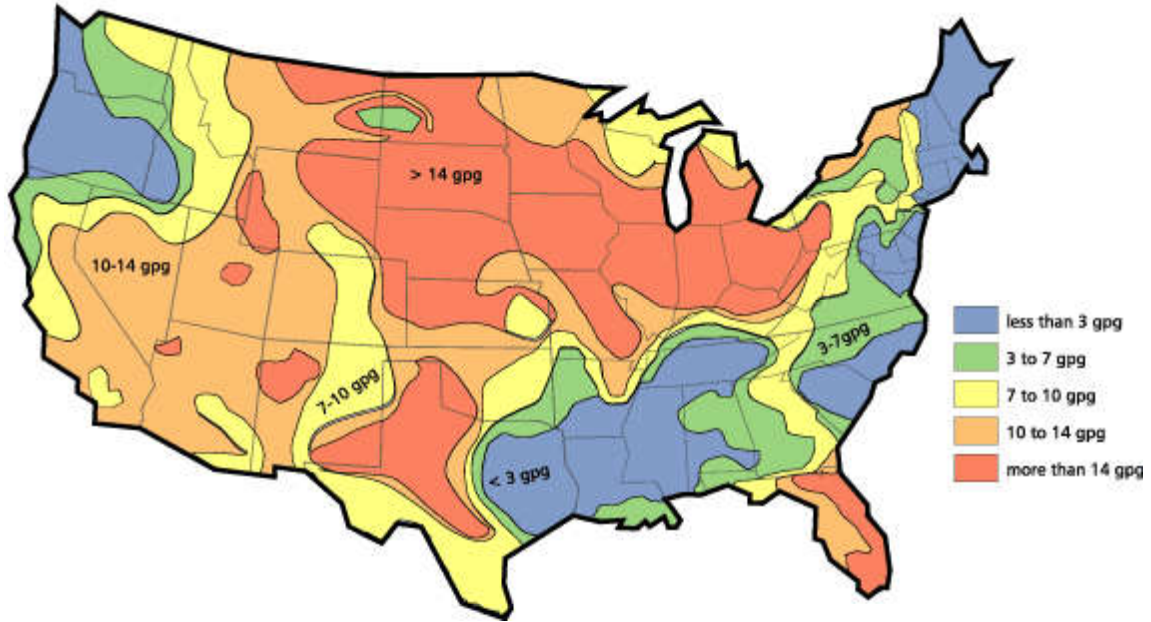

**Figure 1. Hard Water Map of Mainland United States**

## **NOTICE**

The map shown in Figure 1 is provided for general reference only. Water hardness in your geographical location should be confirmed by testing.

## **Water Softener**

Cleaning efficiency and equipment life is increased, chemical use decreased, and the appearance of cleaned carpets enhanced when water softeners are incorporated in hard water areas. HydraMaster strongly urges the use of water softener units with the Boxxer 318 in areas exceeding 3.0 grains per gallon.

Failure to use a water softener in these areas will invalidate the machine's warranty. Referring to the hard water area map shown Figure 1, determine the quality of water in your area and take immediate action if the water hardness exceeds 3.0 grains per gallon.

The relatively low cost of a water softener service is more than made up for by an increased life of machine parts, reduced chemical costs and continued cleaning efficiency. The water softener will also increase the effectiveness of the cleaning chemicals, therefore less chemical will be needed.

Contact a water softener distributor in your area for information on the rental of a simple water treatment unit to carry in your truck. Be sure to charge the water softener in accordance with the capability of the softener.

For example: If the softener will treat 900 gallons of water and the machine uses an average of 30 gallons/hour, for an average of 5 hours a day, this equals 150 gallons per day). In 6 days the machine would use 900 gallons of water. Therefore, the softener would need to be charged every 6 working days for maximum softening.





### **Waste Water Disposal Advisory**

There are laws in most communities prohibiting the dumping of recovered “gray” water from carpet cleaning in any place but a sanitary treatment system.

The cleaning rinse water, recovered into your unit’s vacuum tank, contains materials such as detergents, and must be safely processed before entering streams, rivers and reservoirs.

In most cases, an acceptable method of waste water disposal is to discharge into a municipal sewage treatment system after first filtering out solid material such as carpet fiber. Access to the sanitary system can be obtained through a toilet, laundry drain, RV dump, etc. Permission should first be obtained from any concerned party or agency.

One disposal method which usually complies with the law is to accumulate the waste water and haul it to an appropriate dump site. Another solution to the disposal problem is to equip your Boxxer 318 with an Automatic Wastewater Disposal System (AWDS). These systems are designed to remove waste water from the extractor’s recovery system and actively pump the water through hoses to a suitable disposal drain.

HydraMaster makes an AWDS aSystem which can be ordered with new equipment or installed later.

When properly configured, the systems will continuously monitor the level of waste water and pump it out simultaneously with the cleaning operation. The hidden benefit of this process is that the technician does not have to stop his/her cleaning to empty the recovery tank.

## **NOTICE**

**IN ACCORDANCE WITH EPA, STATE AND LOCAL LAWS, DO NOT DISPOSE OF WASTE WATER INTO GUTTERS, STORM DRAINS, STREAMS, RESERVOIRS, ETC.**

The penalties for non-compliance can be serious. Always check local laws and regulations to be sure you are in compliance.

# Operating Instructions

## START-UP PROCEDURE

1. Perform all daily and periodic maintenance as specified in Section 4 of the Owner's Manual.
2. Connect a garden hose to supply water to the truckmount. If used, turn the "PUMP-IN" switch to the "ON" position (see Figure 2).

## NOTICE

The water box must be full prior to starting the truckmount.

3. Connect the cleaning tool to the length of hose required to perform the cleaning job.
4. Turn the key to "ON". Pull the choke and start the truckmount with the throttle cable fully depressed ("IDLE" position - see Figure 2)
5. After the engine starts, push the choke in and allow the truckmount to run in "IDLE" for 2 - 3 minutes to warm up.
6. Pull the throttle cable to full extension and twist the handle clockwise to lock.

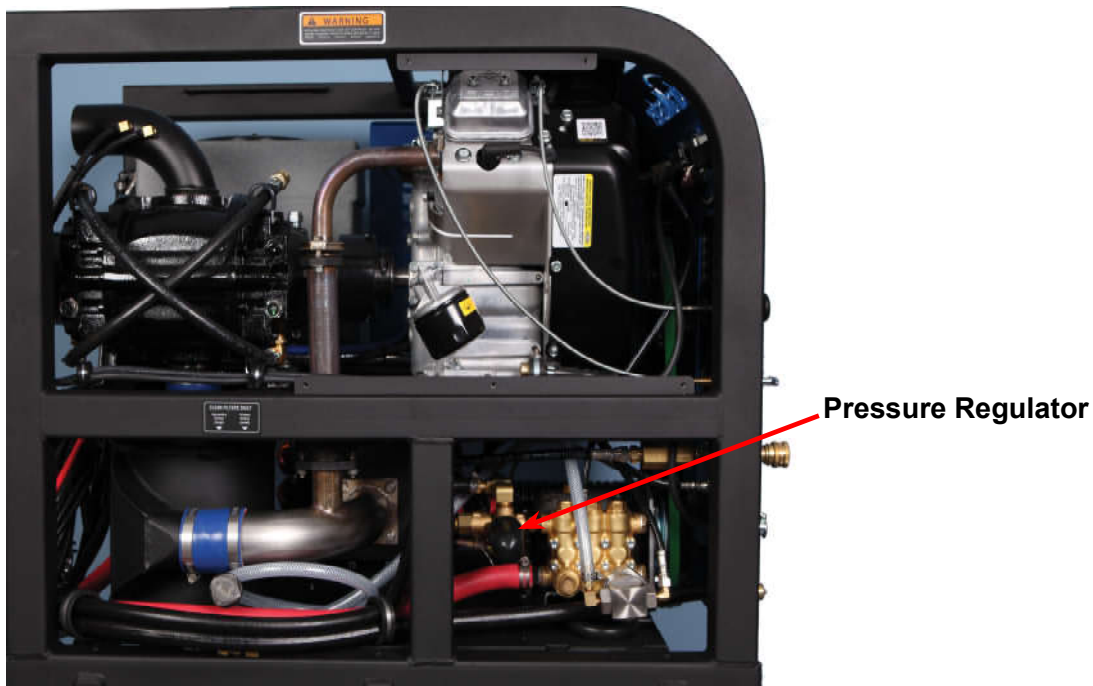

Figure 2. Location of Throttle, Choke and Pump-In/Pump Clutch Switch



Figure 3. Front View of the GTXR Console

7. Press the “PUMP CONTROL” switch to engage the pump clutch for carpet cleaning or upholstery cleaning as follows:
  - a. Switch to the “HP Only” if connected to a fresh water supply from a building.
  - b. Switch to the “HP ON & Pump-In ON” if connected to a fresh water tank.
8. Set the temperature to the desired level on the “TEMPERATURE” knob.
9. If used, turn the “AUTO PUMP-OUT” switch to the “ON” position.
10. Adjust the “PRESSURE REGULATOR”, located on the left hand side of the machine, to the desired cleaning pressure level.
  - a. Suggested Settings:
    - Carpet Cleaning: 300 - 400 psi
    - Hard Surface Cleaning: 1,000 psi or as indicated on the tool
11. Turn the “CHEMICAL SELECTION VALVE” to the “PRIME” position to purge any air from the system.



**Figure 4. Side View of the GTXR Console**

- a. With the truckmount running at full throttle, block off the vacuum intake to the recovery tank. The vacuum gauge should read 12”-14” Hg. This will assist in priming the chemical system.
  - b. Allow the chemical to flow through the chemical meter at full flow for 30 seconds.
  - c. Turn the “CHEMICAL SELECTION VALVE” to “ON.” The restriction can now be removed from the vacuum inlet.
  - d. While spraying solution from the cleaning tool adjust the chemical flow by turning the “CHEMICAL METERING CONTROL KNOB”.
12. Begin cleaning.

## CAUTION

Never perform cleaning operations when the truckmount engine is running at the IDLE throttle position. Failure to follow this caution will increase the risk of serious component or engine damage.

### WATER EXTRACTION PROCEDURE

To perform water extraction, set the “PUMP CONTROL” switch to the flood extraction position. This will disengage the pump clutch, allowing for the machine to run without fresh water connected to the machine.

### SHUT DOWN PROCEDURE

1. Flush clean water through the chemical system for 10 seconds. Turn the “CHEMICAL SELECTION VALVE” to “OFF.”
2. Cool the truckmount down by turning the “TEMPERATURE CONTROL” dial to the lowest position (counter-clockwise). Spray the cleaning wand into the vacuum hose for 3 - 5 minutes. The chemical is now flushed from the truckmount, hoses and cleaning tool.
3. Remove the vacuum hose.
4. Lubricate the blower to prevent it from rusting internally.
  - a. Allow the unit to run for a few minutes with the vacuum hose disconnected in order to remove moisture from the blower.
  - b. Cap off the inlet(s) to the vacuum tank.
  - c. Spray a HydraMaster-recommended spray lubricant into the “BLOWER LUBE PORT” for about 5 to 7 seconds while the unit is running (see Figure 3).
  - d. Allow machine to run additional 2 to 5 minutes under load to flush off lubricant.
  - e. Uncap the inlet(s) and run the unit for another minute to allow the blower to cool down.
5. If freeze guarding is necessary perform the procedure at this time. See Section 4 of the Freeze Guarding section in the Owner’s Manual.
6. Return the engine throttle to the “IDLE” position.
7. Turn the key to “OFF.”
8. Drain the water box using the valve.
9. Drain the vacuum tank in an appropriate location.

## NOTICE

In accordance with the EPA, state and local laws, do not dispose of water into gutters, storm drains, streams, reservoirs, etc.

10. Perform daily maintenance as specified in the Owner’s Manual.

# Maintenance and Logs

To avoid costly repairs and downtime, it is imperative to develop and practice good maintenance procedures. All maintenance must be performed by qualified service personnel.

This section covers:

- Operational Maintenance
- Overall Machine Maintenance
- High Pressure Pump Maintenance
- Vacuum System Maintenance
- Descaling Procedure (Required)
- Freeze Guarding
- Tensioning the Pump Drive Belt
- Maintenance Chart

This section also includes a maintenance schedule and maintenance logs which must be correctly and completely filled out. An Interval Hours Maintenance Chart is on page 43 and page 44.

The manufacturer may request to inspect the logs before a warranty claim is honored.

## NOTICE

Record the date and machine hours on the maintenance log provided for your convenience in the Owner's Guide. Records of maintenance must be kept and copies may be required to be furnished to HydraMaster before the warranty is honored. It is recommended that you affix a copy of the log on the vehicle door near your unit for convenience and to serve as a maintenance reminder.

## NOTICE

Please feel free to photocopy any of the logs on the following pages should you need more copies.



## **OPERATIONAL MAINTENANCE**

### **Daily Maintenance**

- Check the engine oil level. Add oil if needed.
- Check the high pressure pump oil. Add oil if needed.
- Inspect and clean the recovery tank filters.
- Inspect and clean the orifices and filters.
- Inspect and clean the garden hose screen.
- Inspect the truckmount for water and oil leaks, loose electrical connections, etc. and repair as needed.
- Lubricate the blower lube port with HydraMaster-recommended spray lubricant.

### **Weekly Maintenance**

- Inspect the recovery tank filters for tears, holes, etc. Repair or replace as needed.
- Inspect the vacuum relief valve. Clean and lubricate as necessary.
- Clean the recovery tank thoroughly with pressure washer.
- Check the oil level in the blower. Add oil if needed.
- Check the pump drive belt for wear and proper tension. Tighten as needed.
- Check all the hoses and wiring for wear and chafing. Secure as needed.
- Flush the water and chemical systems with solution of equal parts white vinegar and water.
- Check all the nuts and bolts. Tighten as needed.
- One time change of the high pressure pump oil after 50 hours of operation. (Every 500 hours thereafter.)
- One time change of the engine oil after 8 hours of operation.
- Change the engine oil every 50 hours. (Every 25 hours if operating in high ambient temperatures or heavy use conditions.) Change oil filter every oil change.

### **Monthly Maintenance**

- Check the engine air filter. Clean or replace as necessary.
- Check the water level in battery. Fill as needed.
- Clean the battery terminals as needed.
- Change the blower oil after first 100 hours of use.

### **Quarterly Maintenance**

- Check the fuel lines. Repair or replace as needed.
- Clean and gap the spark plugs to 0.030". Replace if excessive carbon buildup is visible.
- Change the fuel filter.
- Change pump drive belt.

### **100 Hours**

- Replace spark plugs



## **250 Hours**

- Check coupler element (rubber insert) for cracks or wear. Replace as necessary.

## **500 Hours**

- Change the blower oil.
- Change the high pressure pump oil.
- Check the engine valve clearance (intake and exhaust 0.004" - 0.006")
- Change the fuel filter.
- Check coupler element (rubber insert) for cracks or wear. Replace as necessary.

## **1000 Hours**

- Change air filters.
- Check plug wires. Replace as necessary.
- Check carburetor. Clean or replace as necessary.
- Clean the heat exchanger core.
- Replace coupler element (rubber insert) for cracks or wear.

## **NOTICE**

Refer to the Interval Hours Maintenance chart on page 43 and page 44.



# GTXR

## HIGH PRESSURE PUMP MAINTENANCE

### Daily

Check the oil level and the condition of the oil. The oil level should be up to the center of the sight glass on the rear of the pump or between the “MIN” and “MAX” lines on the dipstick. The dipstick may be found by removing the oil cap.

### Periodically

Change the oil after the initial 50 hours of operation and every 500 hours after that. It may be necessary to replace the pump seals and check valves at 500 hours if the truckmount has been running in high ambient temperatures.

### **CAUTION**

If the oil becomes discolored or contaminated one of the oil seals may be damaged. Do not operate the pump if the crankcase oil has become contaminated. Do not rotate the drive shaft without oil in the crankcase reservoir.

### **CAUTION**

The pump should never be run dry. Running the pump dry will cause premature wear on the seals, packing and plungers. Running the pump dry for a prolonged period of time may cause damage that cannot be repaired and voids warranty.

### **CAUTION**

Do not run the pump with frozen water in the manifold. If there is a risk of freezing, freeze guard the truckmount. See page 30 of this section for freeze guarding information.

### Service

The next few pages explain how to disassemble and inspect all user serviceable parts of the pump.

### **CAUTION**

Do not disassemble the pump unless you are a skilled mechanic. For assistance, contact your distributor.

## Valve Maintenance (See Figure 5)

1. Using a 22-mm wrench or socket, remove all six valve caps on the manifold of the pump.
2. Examine each valve cap O-ring for cuts or distortions and replace if worn.
3. Using needle nose pliers, remove the suction and delivery check valves. The valve assembly usually stays together when removing. If the valve comes apart, use the needle nose pliers or reverse pliers to remove the remaining parts.
4. Inspect each suction and delivery check valve assembly for wear and pitting, and replace if necessary. The valve assembly consists of the plastic cage, spring, valve seat, poppet and O-ring. One valve kit is needed for complete valve change of one pump.

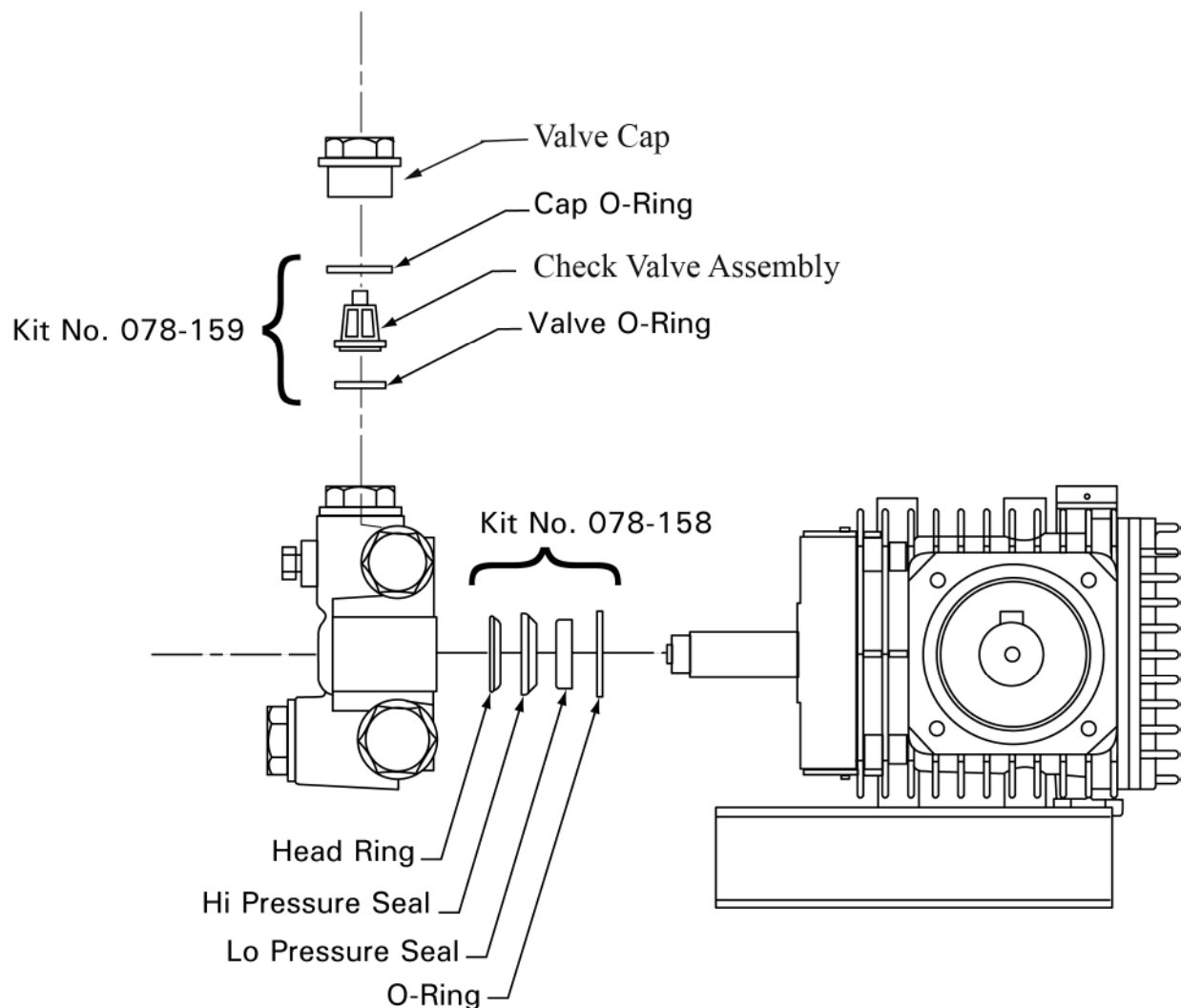

**Figure 5. Servicing the Valves**

# GTXR

5. Replace old valves with new valves by placing the assembly in the valve chamber. Press down firmly on the top of the valve assembly.
6. Replace valve caps by applying LOCTITE® 243 to valve cap and torque to 33 ft-lbs.

## Removing and Replacing Pump Manifold

1. Remove the manifold of the pump by taking a 5-mm Allen head wrench and removing the eight head bolts.
2. With the pump firmly secured, take a medium sized flat head screwdriver and apply pressure to the manifold by prying between the crankcase and manifold. Work around from all sides of the manifold evenly until it comes off of the pistons. Keep the manifold properly aligned with the pistons to prevent damage to the seals and pistons.
3. When replacing the manifold, turn the crankshaft of pump until the top of the pistons are closely aligned. Lubricate the pistons and cylinders with grease and evenly press the manifold toward crankcase until flush.

## Seals and V-Packing Maintenance

1. Remove the manifold as previously described. It is possible that the seal and brass retainer ring assembly will stay on the piston or will remain in the manifold when removing it.
2. Carefully remove the brass retainer ring/seal stack. Remove the low-pressure seal using needle nose pliers. Discard the old seal.
3. Remove the outer O-ring by taking a small flat head screwdriver and working it under the O-ring. Simply roll off the old O-ring and discard.
4. The old V-packing stack can be taken apart by hand and discarded.

## Seals and V-Packing Reassembly

1. Generously lubricate parts with grease when reassembling. Examine all brass components for any damage or water residue build-up. Clean or replace as needed.
2. Insert a new low pressure seal by working it in by hand.
3. Install the new outer O-ring by simply starting on one side and working it into the groove.
4. Stack the new V-packing in the correct order and firmly press the assembly into the manifold.
5. Install a new low pressure oil seal by laying the seal into the opening and evenly pressing it into place.
6. Re-install the manifold onto the pump as previously described.

## Plunger Maintenance

1. Remove the manifold as previously described. Remove the packing retainers if they remain on the pistons after removing the manifold.
2. Remove the nut and washer on the end of the piston using a 13-mm wrench or socket.
3. Slide the ceramic plunger and the remaining washer from the piston guide. Inspect the ceramic piston, O-ring and washers for wear. Replace if necessary.

## Plunger Re-assembly

1. Generously grease the piston guide. Replace the O-ring making sure it does not twist or roll.
2. Slide the lower washer and ceramic bushing onto the piston guide.
3. Place a small amount of LOCTITE 243™ on the piston guide threads. Replace the old washer and thread the nut onto the piston guide. Torque to 4.5 ft-lbs.

## Servicing the Crankcase

1. While the manifold and plungers are removed, rotate the crankshaft by hand. Closely examine the crankcase oil seals for drying, cracking or leaking.
2. Consult the local HydraMaster distributor if crankcase servicing is necessary.

## VACUUM SYSTEM MAINTENANCE

The vacuum pump in this machine is commonly referred to as a “rotary positive displacement blower” or “blower” for short. The performance and life of the truckmount is greatly dependent on the care and proper maintenance it receives. Review the blower’s owner’s manual, which has been included, for a better understanding of this piece of machinery.

To protect the blower from overloading and damaging itself, a vacuum relief system is installed on the recovery tank. When the recovery tank inlet is completely sealed off, a maximum of 12” Hg will be attained.

### CAUTION

Solid objects entering the blower will cause serious damage to the internal components of the blower. Extreme caution should be used when the truckmount is being run for test purposes with the inlet to the blower open to the atmosphere.

### CAUTION

Foam passing through the blower can lead to serious problems with the truckmount. It is important to keep the recovery tank free of foam. The tank is protected from overflowing by a float kill switch; however, this switch is not activated by foam.

### Daily

At the end of each day the internal components of the blower need to be lubricated. This helps to prevent rust deposits and prolongs the life of the truckmount.

Lubricate the blower to prevent it from rusting internally by:

1. Allowing the unit to run for a few minutes with the vacuum hose disconnected in order to remove moisture from the blower.
2. Capping off the inlet(s) to the recovery tank.
3. Spraying a HydraMaster-recommended spray lubricant into the “BLOWER LUBE PORT” for about 5 to 7 seconds while the unit is running.
4. Uncapping the inlet(s) and run the unit for another minute to allow the blower to cool down.

### Periodically

Change the oil in both ends of the blower after the initial 100 hours of use. Change the oil each 500 hours of use thereafter.

## DESCALING PROCEDURE (REQUIRED)

Scale deposits on the interior of the heating system can cause a noticeable loss in heating performance. Deposits of this kind result from hard water deposits. The frequency with which descaling procedures are required will vary. If the area has particularly hard water, you may have to descale often.

To descale the system, add an appropriate descaler chemical to the water box. Circulate it through the system. Let it stand. Flush and repeat as necessary. Clean all screens and strainers, and check them frequently following descaling.

### NOTICE

If using TM DeScaler™ through the flow meter, make sure to run clean water through the flow meter after this procedure.

To descale using the recirculation kit (P/N 000-078-058), start with an empty water box.

1. Fill a third of the water box with TM DeScaler. Follow the recommendations on the TM DeScaler label for proportions. Verify that the float is not lying horizontal, but floats below.
2. Attach the recirculation fitting provided in the kit to the garden hose quick connect (see Figure 6) and this combination to the front of the truckmount.
3. Attach one section of the solution hose to the outgoing solution fitting on the front of the truckmount and the other end to the garden hose and recirculation fitting combination that is attached to the front of the truckmount. Additional hoses may be attached inline if descaling of hoses is needed.
4. Start the truckmount and allow it to run for 3 - 5 minutes. Do not leave the TM DeScaler solution in the system. Flush the system with clean water and turn the truckmount OFF.

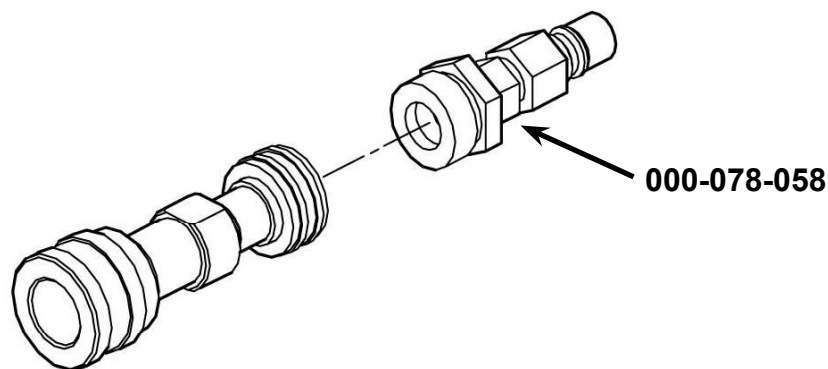

**Figure 6. Recirculation Fitting**

## **FREEZE GUARDING**

To avoid permanent damage to the truckmount, it is imperative to follow the freeze guard procedure whenever the possibility of freezing temperatures exists.

### **CAUTION**

When disposing of antifreeze follow local laws and regulations. Do not discard into storm sewers, septic systems, or onto the ground.

### **⚠ WARNING**

Antifreeze is harmful or fatal if swallowed. Do not store in open or unlabeled containers. Keep out of reach of children and animals.

### **Freeze Guard Procedure**

1. With the truckmount turned off and the incoming water line disconnected, open the water box drain valve on the front of the truckmount. Allow the system to fully drain.
2. Add 2 gallons of 50/50 antifreeze and water mix to the water box.
3. Attach a section of solution hose to the outgoing solution fitting on the front of the machine. Attach the opposite end to the recirculation fitting. (If more sections of hose are to be freeze guarded attach those inline.)
4. Start the truckmount and allow it to run for 2 to 3 minutes. This will distribute antifreeze solution throughout the truckmount.
5. Remove the chemical feed line from the chemical jug. Turn the selector valve to "PRIME." This will vacuum the chemical remaining in the lines to the recovery tank.

### **NOTICE**

If using the recirculation kit, skip ahead to step 7.

6. Remove the quick connect from the truckmount.
7. Spray the antifreeze and water mix out of the truckmount and into a container to reclaim the solution. Run the truckmount until there is no more solution coming from the truckmount..
8. The truckmount is now freeze guarded. Remember to flush antifreeze from the system prior to carpet cleaning. See the following procedure.

## NOTICE

The reclaimed antifreeze solution may be used three times before being discarded.

## NOTICE

To freeze guard the hoses and wand perform step 7 with the items to be freeze guarded attached.

### Recovering Antifreeze for Re-Use

1. Attach all hoses and wands which have been freeze guarded to the truckmount.
2. Attach the incoming water source to the front of the truckmount.
3. Start the truckmount.
4. Spray the solution through the hoses and wands into a sealable container until all signs of antifreeze are gone.

### Freeze Protection of the Pump-In System

1. Drain the fresh water tank.
2. Remove the garden hose adapter from the pump-in pump hose and position the hose so it is pointing outside the van.
3. Turn on the pump-in pump and run for 1-2 minutes until all the water is purged from the hose.

## NOTICE

The next time the truckmount is used it may take a few minutes before the water box begins to fill.



## TENSIONING THE PUMP DRIVE BELT

1. Remove the Boxxer 318 grill to gain access to the idler pulley.
2. Loosen but **do not remove** the 2 ¼" long bolt (P/N 000-143-041) on the idler pulley. See section 9 in the Owner's Manual.
3. Remove the right cover of the machine to gain access to the tensioning screw.
4. Adjust the tension of the belt by turning the 4" long screw (P/N 000-143-376).
5. After the proper belt tension is achieved, tighten the ½" bolt on the idler pulley.

### CAUTION

Ensure there is no contact between idler assembly (including belt) and no other part of the truckmount. Contact between the parts could result in damage to the truckmount.

6. Replace the right cover and grill.

## Weekly Maintenance

	Date							
Hour Meter Reading								
Technician Initials								
Inspect the recovery tank filters for tears, holes, etc. Repair or replace as needed.	<input type="checkbox"/>	<input type="checkbox"/>	<input type="checkbox"/>	<input type="checkbox"/>	<input type="checkbox"/>	<input type="checkbox"/>	<input type="checkbox"/>	<input type="checkbox"/>
Inspect the vacuum relief valve. Clean and lubricate as necessary.	<input type="checkbox"/>	<input type="checkbox"/>	<input type="checkbox"/>	<input type="checkbox"/>	<input type="checkbox"/>	<input type="checkbox"/>	<input type="checkbox"/>	<input type="checkbox"/>
Clean the recovery tank thoroughly with pressure washer.	<input type="checkbox"/>	<input type="checkbox"/>	<input type="checkbox"/>	<input type="checkbox"/>	<input type="checkbox"/>	<input type="checkbox"/>	<input type="checkbox"/>	<input type="checkbox"/>
Check the oil level in the blower. Add oil if needed.	<input type="checkbox"/>	<input type="checkbox"/>	<input type="checkbox"/>	<input type="checkbox"/>	<input type="checkbox"/>	<input type="checkbox"/>	<input type="checkbox"/>	<input type="checkbox"/>
Check the pump drive belt for wear and proper tension. Tighten as needed.	<input type="checkbox"/>	<input type="checkbox"/>	<input type="checkbox"/>	<input type="checkbox"/>	<input type="checkbox"/>	<input type="checkbox"/>	<input type="checkbox"/>	<input type="checkbox"/>
Flush the water and chemical systems with solution of equal parts white vinegar and water.	<input type="checkbox"/>	<input type="checkbox"/>	<input type="checkbox"/>	<input type="checkbox"/>	<input type="checkbox"/>	<input type="checkbox"/>	<input type="checkbox"/>	<input type="checkbox"/>
Check all the nuts and bolts. Tighten as needed.	<input type="checkbox"/>	<input type="checkbox"/>	<input type="checkbox"/>	<input type="checkbox"/>	<input type="checkbox"/>	<input type="checkbox"/>	<input type="checkbox"/>	<input type="checkbox"/>
One time change of the high pressure pump oil after 50 hours of operation. (Every 500 hours thereafter.)	<input type="checkbox"/>	<input type="checkbox"/>	<input type="checkbox"/>	<input type="checkbox"/>	<input type="checkbox"/>	<input type="checkbox"/>	<input type="checkbox"/>	<input type="checkbox"/>
One time change of the engine oil after 8 hours of operation.	<input type="checkbox"/>	<input type="checkbox"/>	<input type="checkbox"/>	<input type="checkbox"/>	<input type="checkbox"/>	<input type="checkbox"/>	<input type="checkbox"/>	<input type="checkbox"/>
Change the engine oil every 50 hours. (Every 25 hours if operating in high ambient temperatures or heavy use conditions.) Change oil filter every oil change.	<input type="checkbox"/>	<input type="checkbox"/>	<input type="checkbox"/>	<input type="checkbox"/>	<input type="checkbox"/>	<input type="checkbox"/>	<input type="checkbox"/>	<input type="checkbox"/>

## ATTENTION Special Maintenance

One time change of the engine oil after 8 hours of operation.	<input type="checkbox"/>							
One time change of the high pressure pump oil after 50 hours of operation. (Every 500 hours thereafter.)	<input type="checkbox"/>							
Change the blower oil after first 100 hours of use.	<input type="checkbox"/>							

## Monthly Maintenance

Check the engine air filter. Clean or replace as necessary.								<input type="checkbox"/>
Check the water level in battery. Fill as needed.								<input type="checkbox"/>
Clean the battery terminals as needed.								<input type="checkbox"/>
Change the blower oil after first 100 hours of use.								<input type="checkbox"/>

---

## Quarterly Maintenance

---

Check the fuel lines. Repair or replace as needed.	<input type="checkbox"/>
Clean and gap the spark plugs to 0.030". Replace if excessive carbon buildup is visible.	<input type="checkbox"/>
Change the fuel filter.	<input type="checkbox"/>
Change pump drive belt.	<input type="checkbox"/>

---

## 100 Hours Maintenance

---

Replace spark plugs	<input type="checkbox"/>	<input type="checkbox"/>
---------------------	--------------------------	--------------------------

---

## 250 Hours Maintenance

---

Check coupler element (rubber insert) for cracks or wear. Replace as necessary.	<input type="checkbox"/>
---	--------------------------

---

## 500 Hours Maintenance

---

Change the blower oil.	<input type="checkbox"/>
Change the high pressure pump oil.	<input type="checkbox"/>
Check the engine valve clearance (intake and exhaust 0.004" - 0.006")	<input type="checkbox"/>
Change the fuel filter.	<input type="checkbox"/>
Check coupler element (rubber insert) for cracks or wear. Replace as necessary.	<input type="checkbox"/>

---

## 1000 Hours Maintenance

---

Change air filters.	<input type="checkbox"/>
Check plug wires. Replace as necessary	<input type="checkbox"/>
Check carburetor. Clean or replace as necessary.	<input type="checkbox"/>
Clean the heat exchanger core.	<input type="checkbox"/>
Replace coupler element (rubber insert) for cracks or wear.	<input type="checkbox"/>

---

## Weekly Maintenance

	Date	Hour Meter Reading	Technician Initials					
Inspect the recovery tank filters for tears, holes, etc. Repair or replace as needed.	<input type="checkbox"/>	<input type="checkbox"/>	<input type="checkbox"/>	<input type="checkbox"/>	<input type="checkbox"/>	<input type="checkbox"/>	<input type="checkbox"/>	<input type="checkbox"/>
Inspect the vacuum relief valve. Clean and lubricate as necessary.	<input type="checkbox"/>	<input type="checkbox"/>	<input type="checkbox"/>	<input type="checkbox"/>	<input type="checkbox"/>	<input type="checkbox"/>	<input type="checkbox"/>	<input type="checkbox"/>
Clean the recovery tank thoroughly with pressure washer.	<input type="checkbox"/>	<input type="checkbox"/>	<input type="checkbox"/>	<input type="checkbox"/>	<input type="checkbox"/>	<input type="checkbox"/>	<input type="checkbox"/>	<input type="checkbox"/>
Check the oil level in the blower. Add oil if needed.	<input type="checkbox"/>	<input type="checkbox"/>	<input type="checkbox"/>	<input type="checkbox"/>	<input type="checkbox"/>	<input type="checkbox"/>	<input type="checkbox"/>	<input type="checkbox"/>
Check the pump drive belt for wear and proper tension. Tighten as needed.	<input type="checkbox"/>	<input type="checkbox"/>	<input type="checkbox"/>	<input type="checkbox"/>	<input type="checkbox"/>	<input type="checkbox"/>	<input type="checkbox"/>	<input type="checkbox"/>
Flush the water and chemical systems with solution of equal parts white vinegar and water.	<input type="checkbox"/>	<input type="checkbox"/>	<input type="checkbox"/>	<input type="checkbox"/>	<input type="checkbox"/>	<input type="checkbox"/>	<input type="checkbox"/>	<input type="checkbox"/>
Check all the nuts and bolts. Tighten as needed.	<input type="checkbox"/>	<input type="checkbox"/>	<input type="checkbox"/>	<input type="checkbox"/>	<input type="checkbox"/>	<input type="checkbox"/>	<input type="checkbox"/>	<input type="checkbox"/>
One time change of the high pressure pump oil after 50 hours of operation. (Every 500 hours thereafter.)	<input type="checkbox"/>	<input type="checkbox"/>	<input type="checkbox"/>	<input type="checkbox"/>	<input type="checkbox"/>	<input type="checkbox"/>	<input type="checkbox"/>	<input type="checkbox"/>
One time change of the engine oil after 8 hours of operation.	<input type="checkbox"/>	<input type="checkbox"/>	<input type="checkbox"/>	<input type="checkbox"/>	<input type="checkbox"/>	<input type="checkbox"/>	<input type="checkbox"/>	<input type="checkbox"/>
Change the engine oil every 50 hours. (Every 25 hours if operating in high ambient temperatures or heavy use conditions.) Change oil filter every oil change.	<input type="checkbox"/>	<input type="checkbox"/>	<input type="checkbox"/>	<input type="checkbox"/>	<input type="checkbox"/>	<input type="checkbox"/>	<input type="checkbox"/>	<input type="checkbox"/>

## ATTENTION Special Maintenance

One time change of the engine oil after 8 hours of operation.	<input type="checkbox"/>
One time change of the high pressure pump oil after 50 hours of operation. (Every 500 hours thereafter.)	<input type="checkbox"/>
Change the blower oil after first 100 hours of use.	<input type="checkbox"/>

## Monthly Maintenance

Check the engine air filter. Clean or replace as necessary.	<input type="checkbox"/>					<input type="checkbox"/>
Check the water level in battery. Fill as needed.	<input type="checkbox"/>					<input type="checkbox"/>
Clean the battery terminals as needed.	<input type="checkbox"/>					<input type="checkbox"/>
Change the blower oil after first 100 hours of use.	<input type="checkbox"/>					<input type="checkbox"/>

---

## Quarterly Maintenance

---

Check the fuel lines. Repair or replace as needed.	<input type="checkbox"/>
Clean and gap the spark plugs to 0.030". Replace if excessive carbon buildup is visible.	<input type="checkbox"/>
Change the fuel filter.	<input type="checkbox"/>
Change pump drive belt.	<input type="checkbox"/>

---

## 100 Hours Maintenance

---

Replace spark plugs	<input type="checkbox"/>	<input type="checkbox"/>
---------------------	--------------------------	--------------------------

---

## 250 Hours Maintenance

---

Check coupler element (rubber insert) for cracks or wear. Replace as necessary.	<input type="checkbox"/>
---	--------------------------

---

## 500 Hours Maintenance

---

Change the blower oil.	<input type="checkbox"/>
Change the high pressure pump oil.	<input type="checkbox"/>
Check the engine valve clearance (intake and exhaust 0.004" - 0.006")	<input type="checkbox"/>
Change the fuel filter.	<input type="checkbox"/>
Check coupler element (rubber insert) for cracks or wear. Replace as necessary.	<input type="checkbox"/>

---

## 1000 Hours Maintenance

---

Change air filters.	<input type="checkbox"/>
Check plug wires. Replace as necessary	<input type="checkbox"/>
Check carburetor. Clean or replace as necessary.	<input type="checkbox"/>
Clean the heat exchanger core.	<input type="checkbox"/>
Replace coupler element (rubber insert) for cracks or wear.	<input type="checkbox"/>

---

## Weekly Maintenance

Date								
Hour Meter Reading								
Technician Initials								
Inspect the recovery tank filters for tears, holes, etc. Repair or replace as needed.	<input type="checkbox"/>	<input type="checkbox"/>	<input type="checkbox"/>	<input type="checkbox"/>	<input type="checkbox"/>	<input type="checkbox"/>	<input type="checkbox"/>	<input type="checkbox"/>
Inspect the vacuum relief valve. Clean and lubricate as necessary.	<input type="checkbox"/>	<input type="checkbox"/>	<input type="checkbox"/>	<input type="checkbox"/>	<input type="checkbox"/>	<input type="checkbox"/>	<input type="checkbox"/>	<input type="checkbox"/>
Clean the recovery tank thoroughly with pressure washer.	<input type="checkbox"/>	<input type="checkbox"/>	<input type="checkbox"/>	<input type="checkbox"/>	<input type="checkbox"/>	<input type="checkbox"/>	<input type="checkbox"/>	<input type="checkbox"/>
Check the oil level in the blower. Add oil if needed.	<input type="checkbox"/>	<input type="checkbox"/>	<input type="checkbox"/>	<input type="checkbox"/>	<input type="checkbox"/>	<input type="checkbox"/>	<input type="checkbox"/>	<input type="checkbox"/>
Check the pump drive belt for wear and proper tension. Tighten as needed.	<input type="checkbox"/>	<input type="checkbox"/>	<input type="checkbox"/>	<input type="checkbox"/>	<input type="checkbox"/>	<input type="checkbox"/>	<input type="checkbox"/>	<input type="checkbox"/>
Flush the water and chemical systems with solution of equal parts white vinegar and water.	<input type="checkbox"/>	<input type="checkbox"/>	<input type="checkbox"/>	<input type="checkbox"/>	<input type="checkbox"/>	<input type="checkbox"/>	<input type="checkbox"/>	<input type="checkbox"/>
Check all the nuts and bolts. Tighten as needed.	<input type="checkbox"/>	<input type="checkbox"/>	<input type="checkbox"/>	<input type="checkbox"/>	<input type="checkbox"/>	<input type="checkbox"/>	<input type="checkbox"/>	<input type="checkbox"/>
One time change of the high pressure pump oil after 50 hours of operation. (Every 500 hours thereafter.)	<input type="checkbox"/>	<input type="checkbox"/>	<input type="checkbox"/>	<input type="checkbox"/>	<input type="checkbox"/>	<input type="checkbox"/>	<input type="checkbox"/>	<input type="checkbox"/>
One time change of the engine oil after 8 hours of operation.	<input type="checkbox"/>	<input type="checkbox"/>	<input type="checkbox"/>	<input type="checkbox"/>	<input type="checkbox"/>	<input type="checkbox"/>	<input type="checkbox"/>	<input type="checkbox"/>
Change the engine oil every 50 hours. (Every 25 hours if operating in high ambient temperatures or heavy use conditions.) Change oil filter every oil change.	<input type="checkbox"/>	<input type="checkbox"/>	<input type="checkbox"/>	<input type="checkbox"/>	<input type="checkbox"/>	<input type="checkbox"/>	<input type="checkbox"/>	<input type="checkbox"/>

## ATTENTION Special Maintenance

One time change of the engine oil after 8 hours of operation.								
	<input type="checkbox"/>							
One time change of the high pressure pump oil after 50 hours of operation. (Every 500 hours thereafter.)								
		<input type="checkbox"/>						
Change the blower oil after first 100 hours of use.								
			<input type="checkbox"/>					

## Monthly Maintenance

Check the engine air filter. Clean or replace as necessary.								
					<input type="checkbox"/>			<input type="checkbox"/>
Check the water level in battery. Fill as needed.					<input type="checkbox"/>			<input type="checkbox"/>
Clean the battery terminals as needed.					<input type="checkbox"/>			<input type="checkbox"/>
Change the blower oil after first 100 hours of use.					<input type="checkbox"/>			<input type="checkbox"/>

---

## Quarterly Maintenance

---

Check the fuel lines. Repair or replace as needed.	<input type="checkbox"/>
Clean and gap the spark plugs to 0.030". Replace if excessive carbon buildup is visible.	<input type="checkbox"/>
Change the fuel filter.	<input type="checkbox"/>
Change pump drive belt.	<input type="checkbox"/>

---

## 100 Hours Maintenance

---

Replace spark plugs	<input type="checkbox"/>	<input type="checkbox"/>
---------------------	--------------------------	--------------------------

---

## 250 Hours Maintenance

---

Check coupler element (rubber insert) for cracks or wear. Replace as necessary.	<input type="checkbox"/>
---	--------------------------

---

## 500 Hours Maintenance

---

Change the blower oil.	<input type="checkbox"/>
Change the high pressure pump oil.	<input type="checkbox"/>
Check the engine valve clearance (intake and exhaust 0.004" - 0.006")	<input type="checkbox"/>
Change the fuel filter.	<input type="checkbox"/>
Check coupler element (rubber insert) for cracks or wear. Replace as necessary.	<input type="checkbox"/>

---

## 1000 Hours Maintenance

---

Change air filters.	<input type="checkbox"/>
Check plug wires. Replace as necessary	<input type="checkbox"/>
Check carburetor. Clean or replace as necessary.	<input type="checkbox"/>
Clean the heat exchanger core.	<input type="checkbox"/>
Replace coupler element (rubber insert) for cracks or wear.	<input type="checkbox"/>

---

### Weekly Maintenance

	Date	Hour Meter Reading	Technician Initials					
Inspect the recovery tank filters for tears, holes, etc. Repair or replace as needed.	<input type="checkbox"/>	<input type="checkbox"/>	<input type="checkbox"/>	<input type="checkbox"/>	<input type="checkbox"/>	<input type="checkbox"/>	<input type="checkbox"/>	<input type="checkbox"/>
Inspect the vacuum relief valve. Clean and lubricate as necessary.	<input type="checkbox"/>	<input type="checkbox"/>	<input type="checkbox"/>	<input type="checkbox"/>	<input type="checkbox"/>	<input type="checkbox"/>	<input type="checkbox"/>	<input type="checkbox"/>
Clean the recovery tank thoroughly with pressure washer.	<input type="checkbox"/>	<input type="checkbox"/>	<input type="checkbox"/>	<input type="checkbox"/>	<input type="checkbox"/>	<input type="checkbox"/>	<input type="checkbox"/>	<input type="checkbox"/>
Check the oil level in the blower. Add oil if needed.	<input type="checkbox"/>	<input type="checkbox"/>	<input type="checkbox"/>	<input type="checkbox"/>	<input type="checkbox"/>	<input type="checkbox"/>	<input type="checkbox"/>	<input type="checkbox"/>
Check the pump drive belt for wear and proper tension. Tighten as needed.	<input type="checkbox"/>	<input type="checkbox"/>	<input type="checkbox"/>	<input type="checkbox"/>	<input type="checkbox"/>	<input type="checkbox"/>	<input type="checkbox"/>	<input type="checkbox"/>
Flush the water and chemical systems with solution of equal parts white vinegar and water.	<input type="checkbox"/>	<input type="checkbox"/>	<input type="checkbox"/>	<input type="checkbox"/>	<input type="checkbox"/>	<input type="checkbox"/>	<input type="checkbox"/>	<input type="checkbox"/>
Check all the nuts and bolts. Tighten as needed.	<input type="checkbox"/>	<input type="checkbox"/>	<input type="checkbox"/>	<input type="checkbox"/>	<input type="checkbox"/>	<input type="checkbox"/>	<input type="checkbox"/>	<input type="checkbox"/>
One time change of the high pressure pump oil after 50 hours of operation. (Every 500 hours thereafter.)	<input type="checkbox"/>	<input type="checkbox"/>	<input type="checkbox"/>	<input type="checkbox"/>	<input type="checkbox"/>	<input type="checkbox"/>	<input type="checkbox"/>	<input type="checkbox"/>
One time change of the engine oil after 8 hours of operation.	<input type="checkbox"/>	<input type="checkbox"/>	<input type="checkbox"/>	<input type="checkbox"/>	<input type="checkbox"/>	<input type="checkbox"/>	<input type="checkbox"/>	<input type="checkbox"/>
Change the engine oil every 50 hours. (Every 25 hours if operating in high ambient temperatures or heavy use conditions.) Change oil filter every oil change.	<input type="checkbox"/>	<input type="checkbox"/>	<input type="checkbox"/>	<input type="checkbox"/>	<input type="checkbox"/>	<input type="checkbox"/>	<input type="checkbox"/>	<input type="checkbox"/>

### ATTENTION Special Maintenance

One time change of the engine oil after 8 hours of operation.	<input type="checkbox"/>						
One time change of the high pressure pump oil after 50 hours of operation. (Every 500 hours thereafter.)	<input type="checkbox"/>						
Change the blower oil after first 100 hours of use.	<input type="checkbox"/>						

### Monthly Maintenance

Check the engine air filter. Clean or replace as necessary.							
Check the water level in battery. Fill as needed.	<input type="checkbox"/>						
Clean the battery terminals as needed.	<input type="checkbox"/>						
Change the blower oil after first 100 hours of use.	<input type="checkbox"/>						



---

## Quarterly Maintenance

---

Check the fuel lines. Repair or replace as needed.	<input type="checkbox"/>
Clean and gap the spark plugs to 0.030". Replace if excessive carbon buildup is visible.	<input type="checkbox"/>
Change the fuel filter.	<input type="checkbox"/>
Change pump drive belt.	<input type="checkbox"/>

---

## 100 Hours Maintenance

---

Replace spark plugs	<input type="checkbox"/>	<input type="checkbox"/>
---------------------	--------------------------	--------------------------

---

## 250 Hours Maintenance

---

Check coupler element (rubber insert) for cracks or wear. Replace as necessary.	<input type="checkbox"/>
---	--------------------------

---

## 500 Hours Maintenance

---

Change the blower oil.	<input type="checkbox"/>
Change the high pressure pump oil.	<input type="checkbox"/>
Check the engine valve clearance (intake and exhaust 0.004" - 0.006")	<input type="checkbox"/>
Change the fuel filter.	<input type="checkbox"/>
Check coupler element (rubber insert) for cracks or wear. Replace as necessary.	<input type="checkbox"/>

---

## 1000 Hours Maintenance

---

Change air filters.	<input type="checkbox"/>
Check plug wires. Replace as necessary	<input type="checkbox"/>
Check carburetor. Clean or replace as necessary.	<input type="checkbox"/>
Clean the heat exchanger core.	<input type="checkbox"/>
Replace coupler element (rubber insert) for cracks or wear.	<input type="checkbox"/>

---

## Weekly Maintenance

	Date							
Hour Meter Reading								
Technician Initials								
Inspect the recovery tank filters for tears, holes, etc. Repair or replace as needed.	<input type="checkbox"/>	<input type="checkbox"/>	<input type="checkbox"/>	<input type="checkbox"/>	<input type="checkbox"/>	<input type="checkbox"/>	<input type="checkbox"/>	<input type="checkbox"/>
Inspect the vacuum relief valve. Clean and lubricate as necessary.	<input type="checkbox"/>	<input type="checkbox"/>	<input type="checkbox"/>	<input type="checkbox"/>	<input type="checkbox"/>	<input type="checkbox"/>	<input type="checkbox"/>	<input type="checkbox"/>
Clean the recovery tank thoroughly with pressure washer.	<input type="checkbox"/>	<input type="checkbox"/>	<input type="checkbox"/>	<input type="checkbox"/>	<input type="checkbox"/>	<input type="checkbox"/>	<input type="checkbox"/>	<input type="checkbox"/>
Check the oil level in the blower. Add oil if needed.	<input type="checkbox"/>	<input type="checkbox"/>	<input type="checkbox"/>	<input type="checkbox"/>	<input type="checkbox"/>	<input type="checkbox"/>	<input type="checkbox"/>	<input type="checkbox"/>
Check the pump drive belt for wear and proper tension. Tighten as needed.	<input type="checkbox"/>	<input type="checkbox"/>	<input type="checkbox"/>	<input type="checkbox"/>	<input type="checkbox"/>	<input type="checkbox"/>	<input type="checkbox"/>	<input type="checkbox"/>
Flush the water and chemical systems with solution of equal parts white vinegar and water.	<input type="checkbox"/>	<input type="checkbox"/>	<input type="checkbox"/>	<input type="checkbox"/>	<input type="checkbox"/>	<input type="checkbox"/>	<input type="checkbox"/>	<input type="checkbox"/>
Check all the nuts and bolts. Tighten as needed.	<input type="checkbox"/>	<input type="checkbox"/>	<input type="checkbox"/>	<input type="checkbox"/>	<input type="checkbox"/>	<input type="checkbox"/>	<input type="checkbox"/>	<input type="checkbox"/>
One time change of the high pressure pump oil after 50 hours of operation. (Every 500 hours thereafter.)	<input type="checkbox"/>	<input type="checkbox"/>	<input type="checkbox"/>	<input type="checkbox"/>	<input type="checkbox"/>	<input type="checkbox"/>	<input type="checkbox"/>	<input type="checkbox"/>
One time change of the engine oil after 8 hours of operation.	<input type="checkbox"/>	<input type="checkbox"/>	<input type="checkbox"/>	<input type="checkbox"/>	<input type="checkbox"/>	<input type="checkbox"/>	<input type="checkbox"/>	<input type="checkbox"/>
Change the engine oil every 50 hours. (Every 25 hours if operating in high ambient temperatures or heavy use conditions.) Change oil filter every oil change.	<input type="checkbox"/>	<input type="checkbox"/>	<input type="checkbox"/>	<input type="checkbox"/>	<input type="checkbox"/>	<input type="checkbox"/>	<input type="checkbox"/>	<input type="checkbox"/>

## ATTENTION Special Maintenance

One time change of the engine oil after 8 hours of operation.	<input type="checkbox"/>							
One time change of the high pressure pump oil after 50 hours of operation. (Every 500 hours thereafter.)	<input type="checkbox"/>							
Change the blower oil after first 100 hours of use.	<input type="checkbox"/>							

## Monthly Maintenance

Check the engine air filter. Clean or replace as necessary.								<input type="checkbox"/>
Check the water level in battery. Fill as needed.								<input type="checkbox"/>
Clean the battery terminals as needed.								<input type="checkbox"/>
Change the blower oil after first 100 hours of use.								<input type="checkbox"/>

---

## Quarterly Maintenance

---

Check the fuel lines. Repair or replace as needed.	<input type="checkbox"/>
Clean and gap the spark plugs to 0.030". Replace if excessive carbon buildup is visible.	<input type="checkbox"/>
Change the fuel filter.	<input type="checkbox"/>
Change pump drive belt.	<input type="checkbox"/>

---

## 100 Hours Maintenance

---

Replace spark plugs	<input type="checkbox"/>	<input type="checkbox"/>
---------------------	--------------------------	--------------------------

---

## 250 Hours Maintenance

---

Check coupler element (rubber insert) for cracks or wear. Replace as necessary.	<input type="checkbox"/>
---	--------------------------

---

## 500 Hours Maintenance

---

Change the blower oil.	<input type="checkbox"/>
Change the high pressure pump oil.	<input type="checkbox"/>
Check the engine valve clearance (intake and exhaust 0.004" - 0.006")	<input type="checkbox"/>
Change the fuel filter.	<input type="checkbox"/>
Check coupler element (rubber insert) for cracks or wear. Replace as necessary.	<input type="checkbox"/>

---

## 1000 Hours Maintenance

---

Change air filters.	<input type="checkbox"/>
Check plug wires. Replace as necessary	<input type="checkbox"/>
Check carburetor. Clean or replace as necessary.	<input type="checkbox"/>
Clean the heat exchanger core.	<input type="checkbox"/>
Replace coupler element (rubber insert) for cracks or wear.	<input type="checkbox"/>

---

## DAILY MAINTENANCE - DIAMOND PRODUCTS GTXR

Check the engine oil level. Add oil if needed.  
 Check the high pressure pump oil. Add oil if needed.  
 Inspect and clean the recovery tank filters.  
 Inspect and clean the orifices and filters.  
 Inspect and clean the garden hose screen.  
 Inspect the truckmount for water and oil leaks, loose electrical connections, etc. and repair as needed.  
 Lubricate the blower lube port with HydraMaster-recommended spray lubricant.

### INTERVAL IN HOURS - DIAMOND PRODUCTS GTXR

	Change engine oil and filter after first 8 hours; afterwards, change the engine oil and filter every 50 hours. (Every 25 hours if operating in high ambient temperatures or heavy use conditions.)																							
	Change the blower oil after first 100 hours of use.																							
	Change high pressure pump oil after first 50 hours of operation. (Every 500 hours thereafter.)																							
	25	50	75	100	125	150	175	200	225	250	275	300	325	350	375	400	425	450	475	500	525	550	575	600
Engine oil and filter																								
Blower oil																								
High pressure pump oil																								
<b>SERVICE</b>																								
Inspect recovery tank filters for tears, holes, etc. Repair or replace as needed.	CH	CH	CH	CH	CH	CH	CH	CH	CH	CH	CH	CH	CH	CH	CH	CH	CH	CH	CH	CH	CH	CH	CH	CH
Inspect the vacuum relief valve. Clean and lubricate as necessary.	CH	CH	CH	CH	CH	CH	CH	CH	CH	CH	CH	CH	CH	CH	CH	CH	CH	CH	CH	CH	CH	CH	CH	CH
Clean the recovery tank thoroughly with pressure washer.	C/I	C/I	C/I	C/I	C/I	C/I	C/I	C/I	C/I	C/I	C/I	C/I	C/I	C/I	C/I	C/I	C/I	C/I	C/I	C/I	C/I	C/I	C/I	C/I
Check the oil level in the blower. Add oil if needed.	CH	CH	CH	CH	CH	CH	CH	CH	CH	CH	CH	CH	CH	CH	CH	CH	CH	CH	CH	CH	CH	CH	CH	CH
Check the pump drive belt for wear and proper tension. Tighten as needed.	CH	CH	CH	CH	CH	CH	CH	CH	CH	CH	CH	CH	CH	CH	CH	CH	CH	CH	CH	CH	CH	CH	CH	CH
Check all the hoses and wiring for wear and chafing. Secure as needed.	CH	CH	CH	CH	CH	CH	CH	CH	CH	CH	CH	CH	CH	CH	CH	CH	CH	CH	CH	CH	CH	CH	CH	CH
Flush the water and chemical systems with solution of equal parts white vinegar and water.	F	F	F	F	F	F	F	F	F	F	F	F	F	F	F	F	F	F	F	F	F	F	F	F
Check all the nuts and bolts. Tighten as needed.*	CH	CH	CH	CH	CH	CH	CH	CH	CH	CH	CH	CH	CH	CH	CH	CH	CH	CH	CH	CH	CH	CH	CH	CH
Change the engine oil and filter every 50 hours. (Every 25 hours if operating in high ambient temperatures or heavy use conditions.)		R		R		R		R		R		R		R		R		R		R		R		R
<b>SERVICE</b>	25	50	75	100	125	150	175	200	225	250	275	300	325	350	375	400	425	450	475	500	525	550	575	600
Check the engine air filter. Clean or replace as necessary.				CH				CH				CH				CH				CH				CH
Check the water level in battery. Fill as needed.				CH				CH				CH				CH				CH				CH
Clean the battery terminals as needed.				C/I				C/I				C/I				C/I				C/I				C/I
Replace spark plugs.				R				R				R				R				R				R
<b>SERVICE</b>	25	50	75	100	125	150	175	200	225	250	275	300	325	350	375	400	425	450	475	500	525	550	575	600
Check the coupler element (rubber insert) for cracks or wear. Replace as necessary.										CH											CH			
Check the fuel lines. Repair or replace as needed.												CH												CH
Clean and gap the spark plugs to 0.030". Replace if excessive carbon buildup is visible.												C/I												C/I
Change the fuel filter.												R												R
Change pump drive belt.												R												R
<b>SERVICE</b>	25	50	75	100	125	150	175	200	225	250	275	300	325	350	375	400	425	450	475	500	525	550	575	600
Change the blower oil.																					R			
Change the high pressure pump oil.																					R			
Check the engine valve clearance (intake and exhaust 0.004" - 0.006")																					CH			
Change the fuel filter.																					R			
Check the coupler element (rubber insert) for cracks or wear. Replace as necessary																					CH			
<b>SERVICE</b>	25	50	75	100	125	150	175	200	225	250	275	300	325	350	375	400	425	450	475	500	525	550	575	600
Change air filters.																								
Check plug wires. Replace as necessary.																								
Check carburetor. Clean or replace as necessary.																								
Replace the coupler element (rubber insert) for cracks or wear. Replace as necessary																								
Clean the heat exchanger core.																								

\* Check engine and blower mounting bolts, coupler retaining bolts, exhaust fasteners, etc.

Adjust	A
Check	CH
Clean and Inspect	C/I
Clean and Lubricate	C/L
Flush	F
Replace	R



DAILY MAINTENANCE - DIAMOND PRODUCTS GTXR																									
Check the engine oil level. Add oil if needed.																									
Check the high pressure pump oil. Add oil if needed.																									
Inspect and clean the recovery tank filters.																									
Inspect and clean the orifices and filters.																									
Inspect and clean the garden hose screen.																									
Inspect the truckmount for water and oil leaks, loose electrical connections, etc. and repair as needed.																									
Lubricate the blower lube port with HydraMaster-recommended spray lubricant.																									
INTERVAL IN HOURS - DIAMOND PRODUCTS GTXR																									
Engine oil and filter	Change engine oil and filter after first 8 hours; afterwards, change the engine oil and filter every 50 hours. (Every 25 hours if operating in high ambient temperatures or heavy use conditions.)																								
Blower oil	Change the blower oil after first 100 hours of use.																								
High pressure pump oil	Change high pressure pump oil after first 50 hours of operation, (Every 500 hours thereafter.)																								
SERVICE	625	650	675	700	725	750	775	800	825	850	875	900	925	950	975	1000	1025	1050	1075	1100	1125	1150	1175	1200	
Inspect recovery tank filters for tears, holes, etc. Repair or replace as needed.	CH	CH	CH	CH	CH	CH	CH	CH	CH	CH	CH	CH	CH	CH	CH	CH	CH	CH	CH	CH	CH	CH	CH	CH	CH
Inspect the vacuum relief valve. Clean and lubricate as necessary.	CH	CH	CH	CH	CH	CH	CH	CH	CH	CH	CH	CH	CH	CH	CH	CH	CH	CH	CH	CH	CH	CH	CH	CH	CH
Clean the recovery tank thoroughly with pressure washer.	C/I	C/I	C/I	C/I	C/I	C/I	C/I	C/I	C/I	C/I	C/I	C/I	C/I	C/I	C/I	C/I	C/I	C/I	C/I	C/I	C/I	C/I	C/I	C/I	C/I
Check the oil level in the blower. Add oil if needed.	CH	CH	CH	CH	CH	CH	CH	CH	CH	CH	CH	CH	CH	CH	CH	CH	CH	CH	CH	CH	CH	CH	CH	CH	CH
Check the pump drive belt for wear and proper tension. Tighten as needed.	CH	CH	CH	CH	CH	CH	CH	CH	CH	CH	CH	CH	CH	CH	CH	CH	CH	CH	CH	CH	CH	CH	CH	CH	CH
Check all the hoses and wiring for wear and chafing. Secure as needed.	CH	CH	CH	CH	CH	CH	CH	CH	CH	CH	CH	CH	CH	CH	CH	CH	CH	CH	CH	CH	CH	CH	CH	CH	CH
Flush the water and chemical systems with solution of equal parts white vinegar and water.	F	F	F	F	F	F	F	F	F	F	F	F	F	F	F	F	F	F	F	F	F	F	F	F	F
Check all the nuts and bolts. Tighten as needed.*	CH	CH	CH	CH	CH	CH	CH	CH	CH	CH	CH	CH	CH	CH	CH	CH	CH	CH	CH	CH	CH	CH	CH	CH	CH
Change the engine oil and filter every 50 hours, (Every 25 hours if operating in high ambient temperatures or heavy use conditions.)		R		R		R		R		R		R		R		R		R		R		R		R	
SERVICE	625	650	675	700	725	750	775	800	825	850	875	900	925	950	975	1000	1025	1050	1075	1100	1125	1150	1175	1200	
Check the engine air filter. Clean or replace as necessary.				CH				CH				CH				CH				CH				CH	
Check the water level in battery. Fill as needed.				CH				CH				CH				CH				CH				CH	
Clean the battery terminals as needed.				C/I				C/I				C/I				C/I				C/I				C/I	
Replace spark plugs.			R					R				R				R				R				R	
SERVICE	625	650	675	700	725	750	775	800	825	850	875	900	925	950	975	1000	1025	1050	1075	1100	1125	1150	1175	1200	
Check the coupler element (rubber insert) for cracks or wear. Replace as necessary.						CH										CH									
Check the fuel lines. Repair or replace as needed.												CH													CH
Clean and gap the spark plugs to 0.030". Replace if excessive carbon buildup is visible.												C/I													C/I
Change the fuel filter.												R													R
Change pump drive belt.												R													R
SERVICE	625	650	675	700	725	750	775	800	825	850	875	900	925	950	975	1000	1025	1050	1075	1100	1125	1150	1175	1200	
Change the blower oil.																R									
Change the high pressure pump oil.																R									
Check the engine valve clearance (intake and exhaust 0.004" - 0.006")																CH									
Change the fuel filter.																R									
Check the coupler element (rubber insert) for cracks or wear. Replace as necessary																CH									
SERVICE	625	650	675	700	725	750	775	800	825	850	875	900	925	950	975	1000	1025	1050	1075	1100	1125	1150	1175	1200	
Change air filters.																R									
Check plug wires. Replace as necessary.																CH									
Check carburetor. Clean or replace as necessary.																CH									
Replace the coupler element (rubber insert) for cracks or wear. Replace as necessary																R									
Clean the heat exchanger core.																C/I									

\* Check engine and blower mounting bolts, coupler retaining bolts, exhaust fasteners, etc.

Adjust	A
Check	CH
Clean and Inspect	C/I
Clean and Lubricate	C/L
Flush	F
Replace	R

MAN-46153 Rev. C





## HYDRAMASTER<sup>®</sup> STANDARD SLIDE-IN LIMITED WARRANTY

HydraMaster warrants to the original end user, each new machine, new accessories and genuine replacement parts against defects in material and workmanship under normal use and service. Our obligation under this warranty is limited to repair or replacement of the defective item at our factory or by an Authorized Service Center. Warranty coverage shall begin on the date of purchase by the original end user (as evidenced by your invoice from the factory or Authorized Dealer) or six (6) months from the date the machine was shipped from the factory, whichever is earlier. The warranty registration card must be completed and returned within 30 days of purchase. The warranty coverage period is specified below.

GROUP	Parts <sup>1,2</sup>	Labor <sup>2</sup>
Frame	3 Years	2 Years
Covers	3 Years	2 Years
Vacuum Recovery Tank (Structural only)	3 Years	2 Years
Vacuum Pump – see Note 3	2 Years	2 Years
Chemical Systems	2 Years	2 Years
Hoses, Internal Machine	2 Years	2 Years
Hoses, External Machine	2 Years	2 Years
Valve, High pressure bypass	2 Years	2 Years
Water Heating System	2 Years	2 Years
Pump, High pressure water	2 Years	2 Years
Belts	2 Years	2 Years
Fittings, internal machine	2 Years	2 Years
Filter Screens	2 Years	2 Years
Gauges	2 Years	2 Years
Electrical Components	2 Years	2 Years
Engine	See Note 3	2 Years
Accessories and Fresh Water Tanks	1 Year	1 Year
Replacement Parts – see Note 4	90 Days	NA

**NOTES:**  
1-Parts repaired or replaced are guaranteed for the remainder of the original machine warranty period.  
2-Coverage only applicable to products sold and used in the United States and Canada.  
3-As provided by the original Manufacturer.  
4-Applies to replacement parts only after machine warranty coverage has expired.

This warranty shall not apply to repairs resulting from accidents or misuse, damage in transit, overloading the capacity of the machine, failure due to lack of proper maintenance or care as described in the operating and maintenance instructions. Freezing of any water or chemical related component will VOID all warranties on water or chemical related components, internal or external. Corrosion, deposits and/or build-up in the water, chemical, recovery or heating systems due to hardness in the water used or chemicals which result in deposits, will VOID all warranties on affected components. The use or application of any chemical, including but not limited to acids or solvents, which results in damage to metal, rubber, plastic, or painted parts will VOID all warranties on those parts. Minor adjustments, such as tightening of screws or bolts not connected with the replacement of parts, are not covered. Replacement of expendable wear items including, but not limited to paint, labels and other cosmetic parts are also not covered. Repairs or alterations by an organization other than the factory or an Authorized Service Center are not covered and will void any HydraMaster warranty as to the parts or systems repaired or altered by a non-authorized organization.

**THERE ARE NO WARRANTIES THAT EXTEND BEYOND THE DESCRIPTION OF THE LIMITED WARRANTIES STATED WITHIN. NO OTHER WARRANTY, EXPRESSED OR IMPLIED, INCLUDING BUT NOT LIMITED TO ANY IMPLIED WARRANTY OF MERCHANTABILITY OR FITNESS FOR A PARTICULAR PURPOSE, IS MADE EXCEPT AS EXPRESSLY STATED HEREIN. ANY STATUTORY IMPLIED WARRANTIES, INCLUDING ANY WARRANTY OF MERCHANTABILITY OR FITNESS FOR A PARTICULAR PURPOSE, THAT ARE IMPOSED BY LAW DESPITE THE EXPRESS LIMITATION OR WARRANTIES ABOVE, ARE EXPRESSLY LIMITED TO THE DURATION OF THE WRITTEN WARRANTY. BUYER UNDERSTANDS, ACKNOWLEDGES AND AGREES THAT THE REMEDIES PROVIDED UNDER THIS LIMITED WARRANTY ARE THE SOLE AND EXCLUSIVE REMEDIES AVAILABLE TO THE BUYER. HYDRAMASTER WILL NOT BE LIABLE FOR ANY OTHER OR ADDITIONAL DAMAGES, INCLUDING BUT NOT LIMITED TO INDIRECT, SPECIAL OR CONSEQUENTIAL DAMAGES ARISING OUT OF OR IN CONNECTION WITH THE FURNISHING, PERFORMANCE, USE OF OR INABILITY TO USE THE MACHINE. ANY EXTENSIONS OF OR MODIFICATIONS MADE TO THIS WARRANTY BY A DEALER/DISTRIBUTOR OF HYDRAMASTER ARE THE SOLE RESPONSIBILITY OF THE DEALER/DISTRIBUTOR.**

HydraMaster will pay all freight and transportation charges within the United States, via normal ground shipping means, for replacement of parts covered under this warranty. All material must be properly authorized by HydraMaster prior to being returned. When returning, please provide an explanation of the problem and include the serial number of the machine as well as the name of the selling organization. All defective material must be returned to HydraMaster within 60 days of authorization. The Technical Service department of the authorized Dealer Service Center or the factory will investigate and then contact you.

Transportation of hazardous waste or contaminated equipment is subject to various laws and regulations. In returning machines, parts, or accessories under this limited warranty, the end user must certify in writing that the machines, parts or accessories being returned have not been used for handling, clean up, or disposal of hazardous waste or hazardous materials including but not limited to such things as asbestos, anthrax etc. or if the machines, parts or accessories being returned have been used for handling, clean up, or disposal of hazardous waste or hazardous materials, then the end user must have the machines, parts or accessories decontaminated by licensed and qualified decontamination professionals and provide written certification of this decontamination signed by the decontamination professionals. These machines, parts or accessories are to be returned only to the local HydraMaster Authorized Service Center for Warranty service along with decontamination certification.

HydraMaster reserves the right to change its warranty policy without notice.

HydraMaster is a Nilfisk, Inc. brand.

Rev 3-23-2015-KGO  
CS-46247 Rev. A