



CTS 403 Flex Owner's Manual

Manufactured Exclusively for 

HydraMaster
11015 47th Avenue West
Mukilteo, Washington 98275

MAN-47809 Rev. A, JAN 2020
(P/N 000-182-749)

No part of this manual may be reproduced or used in any form or by any means (i.e. graphic, electronic, photocopying or electronic retrieval systems) without the express written permission of Harris Research Inc. Specifications and information in this document are subject to change without prior notice. All rights reserved. © 2020 Harris Research Inc.



Table of Contents

GENERAL INFORMATION	SECTION 1
Contact Information	1-3
Warnings, Cautions and Notices	1-4
Responsibilities	1-8
Machine Specifications - Console.....	1-10
Machine Specifications - Flex Assemblies.....	1-12
High Altitude Operation	1-13
Local Water Precautions.....	1-13
OPERATING INSTRUCTIONS.....	SECTION 2
Before Operating the CTS 403 Flex	2-1
Startup Procedure - Carpet/Upholstery	2-2
Startup Procedure - Tile.....	2-4
Shut-Down Procedure	2-6
Flex Tank Operation.....	2-7
FREEZE GUARDING	SECTION 3
Freeze Guarding the Carpet/Upholstery System.....	3-2
Freeze Guarding the Tile System	3-3
MACHINE MAINTENANCE	SECTION 4
Operational Maintenance.....	4-2
High Pressure Pump Maintenance	4-4
Vacuum System Maintenance	4-8
Descaling Procedure - Tile.....	4-10
Descaling Procedure- Carpet/Upholstery	4-11
Tensioning the Pump Drive Belt.....	4-12
Pump Tuning Instructions	4-13
Clean QC Filter and Orifice	4-16
Service Heat Exchanger Indicator - CTS 403	4-17
Cleaning Out The Heat Exchanger Of The CTS 403	4-18
SOLUTION FLOW PATHS	SECTION 5
ELECTRICAL SYSTEM.....	SECTION 6
TROUBLESHOOTING	SECTION 7
Heating System	7-2
Engine.....	7-3
Tile System	7-7
Vacuum System.....	7-10



ASSEMBLIES AND PARTS LIST	SECTION 8
Machine Assembly with 35 Gallon Tank and 15 Gallon Tank Parts List	8-4
Machine Assembly with 50 Gallon Tank Parts List	8-6
Console Assembly Parts List	8-13
Blower Assembly Parts List	8-15
Dash Assembly Parts List	8-18
Engine Assembly Parts List	8-21
Exhaust Assembly Parts List	8-22
Diverter Valve Actuator Assembly Parts List	8-23
Exhaust Diverted Assembly Parts List	8-25
Exhaust Diverter Valve Assembly Parts List	8-26
Exhaust Manifold Assembly Parts List	8-27
Frame Assembly Parts List	8-30
Idler Pulley Assembly Parts List	8-31
Solenoid Valve Assembly Parts List	8-32
Back Pressure Switch Mount - CTS 403 Assembly Parts List	8-33
Heat Exchanger Assembly Parts List	8-35
Orifice Assembly Parts List	8-36
Pump Assembly Parts List	8-38
By-Pass Valve Assembly Parts List	8-39
Silencer Assembly Parts List	8-40
Top Cover - CTS 403 Flex Assembly Parts List	8-41
Water Box Assembly Parts List	8-43
70 Gallon Universal Recovery Tank (URT) Assembly Parts List	8-46
Cover, 70 Gal URT, Single Vac Assembly Parts List	8-47
Vacuum Relief Valve, URT Assembly	8-48
Dump Hose Hook Up Kit	8-49
Sacrificial Anode Assembly	8-50
35 Gallon and 15 Gallon Tank Flex Kit Assembly Parts List	8-51
35 Gallon Tank Flex Chemical Caddy Assembly Parts List	8-52
35 Gallon and 15 Gallon Tank Flex Assembly Parts List	8-54
50 Gallon Tank Flex Kit Assembly Parts List	8-55
50 Gallon Tank Flex Chemical Caddy Assembly Parts List	8-56
50 Gallon Tank Flex Assembly Parts List	8-57
Pump Cover Assembly	8-58
Pump - Passenger Flex Kit	8-59
Flex Pump Assembly	8-60
Flex Pump Replacement Parts Kits	8-61
Console Hose Routings	8-62



HOW TO ORDER PARTS SECTION 9

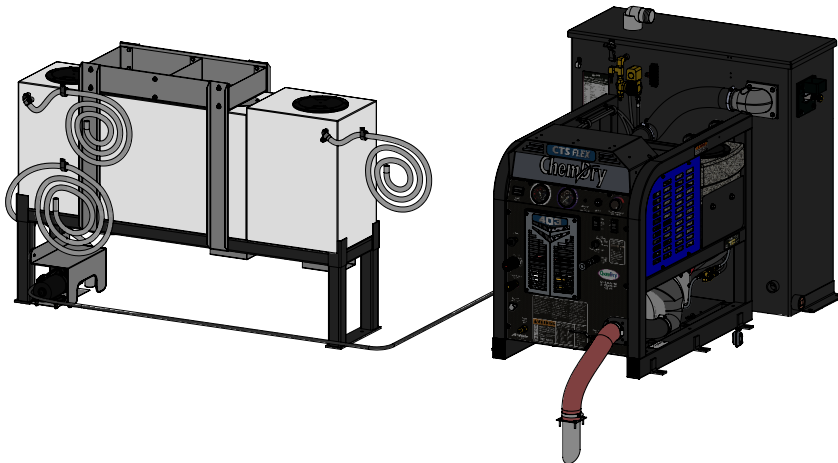
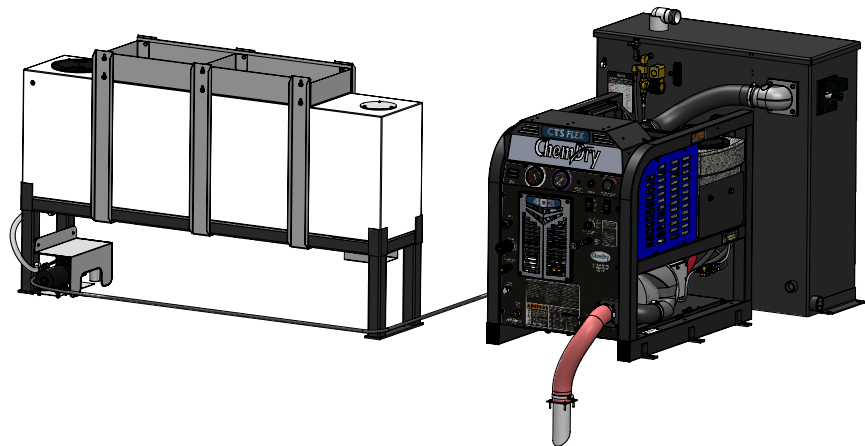
- Warranty Parts Orders 9-1
- Parts Orders 9-1
- Emergencies 9-1

WARRANTY INFORMATION SECTION 10

- Blower 10-1
- High Pressure Water Pump 10-1
- Recovery Tank 10-1
- Chemical System 10-1
- Control Panel 10-1
- Vacuum And Solution Hoses 10-2
- Cleaning Wand And Tool 10-2
- Water Heating System 10-2
- Hard Water Deposits 10-2
- Flex System Warranty 10-4

1- General Information

The CTS 403 Flex is manufactured exclusively for ChemDry by HydraMaster. It integrates HydraMaster's popular and durable truckmounts with the specially designed Flex System which dispenses ChemDry's proprietary solutions for carpet and upholstery cleaning, as well as tile and stone cleaning.



The CTS 403 Flex is available with a 50 gallon tank assembly or a 35 gallon/15 gallon tank assembly.



The truckmount portion of the CTS 403 Flex has been purposely modified to control the Flex System, ensuring that the two systems work seamlessly with each other.

The truckmount system utilizes an internal combustion engine to provide the power necessary to turn both a blower (also referred to as a vacuum pump) and a high pressure water pump.

The heat of the engine and blower exhausts is transferred to the cleaning solution in the heat exchanger of the system.

The solution is recovered by the vacuum generated by the blower and is collected in the recovery tank for proper disposal.

This Owner's Manual provides operating instructions as well as information required for proper maintenance and troubleshooting of the CTS 403 Flex. In addition, assembly illustrations and parts ordering information are included for your convenience.

It is the purpose of this Manual to help you properly understand and maintain your CTS 403 Flex system. Follow the directions and maintenance recommendations carefully, and you will be rewarded with years of profitable, trouble-free operation.

It is imperative that no section be overlooked when preparing for operation of this equipment. Please read this Owner's Manual to familiarize yourself with the operation of the CTS 403 Flex System, paying special attention to all **Warnings and Cautions**.

This section of the manual contains the following helpful information:

- Contact Information
- Warnings, Cautions And Notices
- Machine Specifications - Truckmount
- Machine Specifications - Flex Assemblies
- Responsibilities
- Hard Water Precautions
- Waste Water Disposal Advisory



CONTACT INFORMATION

If you have any questions regarding the operation, maintenance or repair of this machine, please contact your local distributor.

When calling your distributor, be sure to reference the serial number and date of purchase.

FOR YOUR REFERENCE:

Serial No. _____

Date of Purchase: _____

Purchased From (Distributor): _____



WARNINGS, CAUTIONS AND NOTICES

⚠ WARNING

The manufacturer uses this WARNING symbol throughout the guide to warn of possible injury or death.

CAUTION

This CAUTION symbol is used to warn of possible equipment damage.

NOTICE

This NOTICE symbol indicates that federal or state regulatory laws may apply, and also emphasizes supplemental information.

⚠ WARNING

During the operation of the truckmount many components are in motion. Never touch any part of the truckmount that is in motion. Serious injury may result.

⚠ WARNING

During the operation of the truckmount many surfaces will become extremely hot. Never touch hot surfaces. Serious injury may result.

⚠ WARNING

The operation of this truckmount can produce noise levels exceeding 85 decibels to a distance of 10 feet. The Occupational Safety and Health Administration (OSHA) recommends the use of hearing protective equipment if a person is exposed to an average of 85 decibels over an eight hour period. Check with local and state agencies concerning hearing conservation rules.

⚠ WARNING

During the operation of the truckmount carbon monoxide and other toxic fumes are produced. Position the vehicle so that any fumes produced will be directed away from inhabited areas and any points of building entry (doors, windows, air conditioning units, fans, etc.). Do not occupy the vehicle while the truckmount is in operation. Serious injury may result.

⚠ WARNING

During the operation of the truckmount chemicals known to the State of California to cause cancer, birth defects and other reproductive harm are produced by the engine exhaust.

⚠ WARNING

Never operate the truckmount with a portable gas container inside the vehicle. Doing so will increase the risk of fire and explosion. Serious injury or death may result.

⚠ WARNING

Transporting a vented fuel container that presently contains, or has ever contained in the past, a flammable liquid is strictly forbidden by HydraMaster and by federal and state regulations. Doing so will increase the risk of fire and explosion. Serious injury or death may result.



⚠ WARNING

Never smoke in or around the truckmount. Doing so will increase the risk of fire and explosion. Serious injury or death may result.

CAUTION

Be cautious when drilling holes through the van floor. Many vans have critical components mounted directly below the van floor that could be damaged by a misplaced drill bit.

CAUTION

During the operation of the truckmount the exhaust system will become extremely hot. Keep all flammable materials away from the truckmount exhaust system. Failure to do so will increase the risk of fire and explosion. Serious property damage may result.

CAUTION

Never operate the truckmount when the vehicle is tilted more than 10 degrees in any direction. Doing so will result in improper lubrication of the internal components, and will increase the risk serious component or engine damage.

CAUTION

Never perform cleaning operations when the truckmount engine is running at the IDLE throttle position. Failure to do so will increase the risk of serious component or engine damage.

CAUTION

Never operate the truckmount with the vehicle doors closed. Doing so results in extremely high temperatures inside the vehicle and will lead to serious component or engine damage.

CAUTION

Never use concentrated acids or solvents (including d-limonene) in the truckmount water system or chemical system. Use of these products will cause serious component damage.

CAUTION

Never operate the truckmount with a water hardness reading measuring 3.0 grains per gallon or higher. Using reading than 3.0 grains per gallon will cause scale to build up inside the truckmount water system. Scale build up causes serious component damage. Test all water prior to use and use water softening equipment if necessary.

CAUTION

Never allow water to freeze inside the truckmount. Serious component damage will occur. Perform all freeze guarding procedures outlined in the digital Owner's Manual.

CAUTION

Many vehicles have critical components mounted directly below the floor that can easily be damaged. Before drilling holes in the floor of the vehicle, inspect the underside of the vehicle for critical components. Failure to do so may result in damage to the vehicle.

CAUTION

During the operation of this equipment, surfaces will become hot. Do not allow components such as hoses to touch hot surfaces. Failure to heed this warning can result in equipment damage which is not covered by warranty.



RESPONSIBILITIES

The Purchaser's Responsibilities

Prior to purchasing a van, ensure that the payload is suitable for all of the equipment that will be installed and transported. This includes and is not limited to: the truckmount, recovery tanks, fresh water tanks and on-board water, hose reels, hoses, cleaning tools, chemicals, drying equipment, etc. Payload capacity information is available through the auto dealer, the manufacturer's web site, and is also located on the door pillar of the driver's side door.

Purchase a heavy duty Group 24 (550 CCA or better) battery for this truckmount. This is normally available from the installation dealer.

Prior to dropping your van off at the distributor for the truckmount to be installed, have a spray-on bed liner applied to the floor such as Rhino Lining® or Line-X®.

Prior to operating the truckmount read this manual in its entirety and familiarize yourself with the information contained here. Special attention should be paid to all cautions and warnings.

The distributor is responsible for the correct installation of the truckmount. The distributor is also responsible to train you in the correct and proper operation and maintenance of the truckmount.

NOTICE

Any modification of the truckmount may void the warranty.

The Distributor's Responsibility

Acceptance of Shipment

Before accepting the truckmount, check the following:

- The truckmount should be free from any damage during shipping. Do not sign the delivery receipt until you have closely inspected the truckmount and noted any damage on the delivery receipt. Hidden damage may be present even if the box looks okay. It is recommended that the box be opened before signing for the shipment.
- Check the packing list and verify that all items are accounted for.

Installation Responsibilities

- Ensure proper payload capacity. It is the distributor's responsibility to verify that the equipment package does not exceed the vehicle capacity.
- Ensure installation of a safe fuel tap system and through-floor fittings as provided by HydraMaster.
- Proper placement of the truckmount, recovery tank, fresh water tank, and accessories in the vehicle and securing them with bolts and back up plates. The distributor should verify that the owner is in agreement with the layout.
- Ensure proper connection of the fuel lines.
- Ensure proper connection and installation of the battery. Verify that the battery is in accordance with HydraMaster's recommendation.
- Check the pump, vacuum blower and engine oil levels prior to starting the truckmount.
- Start and run the truckmount and check that all systems function properly.
- Test all hoses, wands, etc. for correct operation.
- Ensure timely return of the document package.

Training

The distributor should provide a thorough review of the operation manual with the purchaser along with instruction and familiarization in:

- How all the truckmount's systems function.
- All safety precautions and their importance.
- How to correctly start and shut down the truckmount.
- How to correctly clean with the truckmount.
- Where and how often to check and change component oil levels.
- Freezing damage and how to avoid it. This includes explaining proper freeze guarding procedures.
- How to do basic troubleshooting of the truckmount.
- Hard water damage and how to avoid it. This includes how to determine if hard water exists in your area and the installation and use of water softening systems.
- The truckmount's warranty and warranty procedures.



MACHINE SPECIFICATIONS - CONSOLE

Frame Dimensions	24.0" W x 31" H x 36" D	
Weight	568 lbs	
Engine- Briggs and Stratton Vanguard 23HP	Oil Type	Synthetic 5W-30
	Capacity	Approx. 1 1/2 quarts (48 oz.) when changing oil and filter
	Engine rpm	3,150 rpm
	Fuel Consumption	1.1 gph
Ignition	Electric Key Start	
Vacuum Blower- Tuthill 3006 Competitor Plus SL (Dual Splash Lubrication)	Max. Vac.	12" Hg
	Oil Type	PneuLube or other ISO 100 rating
	Gear End Capacity	Approx. 7.0 oz.
	Drive End Capacity	Approx. 5.0 oz.
	Blower rpm	3,150 rpm
Water Pump	Oil Type	30W non-detergent
Electric Clutch	Capacity - oil	Approx. 8.0 oz.
	Pump Rate	3.5 gallons per minute
	Pump rpm	1,750 rpm
Operating Pressure	0 - 1,000 psi	
Heating System	Stainless Steel and Copper Hybrid	



Standard Equipment	High Pressure Hose	1/4" High Temperature Lined/ Vinyl Cover - 100 ft.
	Vacuum Hose	2" Vacuum Hose- 100 ft.
		1-1/2" Wand Whip Line- 10 ft.
	Recovery Tank	70 gallon MaxAir Universal Tank
	Through Floor Exhaust Kit	
	Battery Box	
	Van Decal	
	Van Installation Kit	
	Owner's Manual (on CD)	
	Owner's Guide (paper copy)	
Optional Equipment	Flex System Tanks	35 gallon/15 gallon
	Flex System Tank	50 gallon
	Automatic Pump Out (APO)	Comet AWDS



MACHINE SPECIFICATIONS - FLEX ASSEMBLIES

50 Gallon Tank with Frame	Dimensions	12" W x 33" H x 60" L
	Weight	113 lbs
35/15 Gallon Tanks with Frame	Dimensions	12" W x 33" H x 53" L
	Weight	108 lbs
Construction	Frames	Steel
	Tanks	Polyethylene

HIGH ALTITUDE OPERATION

Elevation plays a key role in how the truckmount will operate. Operation at high altitude (above 5,000 ft.) may require a high-altitude carburetor jet. Use of this jet at high altitude will improve power, reduce fuel consumption and help reduce excessive carbon build-up in the exhaust and heat exchanger systems.

Contact the local Briggs and Stratton dealer or HydraMaster to obtain the proper jet size. Your local Briggs and Stratton dealer can be located at <http://www.briggsandstratton.com/us/en/support/dealerlocator>.

LOCAL WATER PRECAUTIONS

The quality of water varies greatly. Many areas have an excess of minerals in the water which results in what is commonly called “hard water.” These minerals tend to adhere to the insides of heater coils and other parts of the machines causing damage and a loss of cleaning effectiveness. This influences the reliability and efficiency of equipment in direct proportion to the level of hardness.

Hard Water Advisory

HydraMaster recognizes that any hard water deposits which might occur within the water system of our truckmounts is a serious problem. The precision technology of truckmount heat exchanger systems is intolerant of any foreign material. Hard water deposits will ultimately decrease the performance of the system and are expected to seriously lower the reliability of the machine.

To validate a machine’s warranty, HydraMaster requires that all machines operating in designated “Hard Water Areas” (3.0 grains or more per gallon) be fitted with a water softening system, or a properly installed magnetic-type descaler must be used and maintained. Periodic descaling or acid-rinsing alone is not adequate in these areas. HydraMaster does not recommend any particular type or brand; however, the relative effectiveness of some types of magnetic descalers or softeners may require additional periodic use of descaling agents.

HydraMaster also recommends, in the strongest possible terms, that machines in all areas be fitted with a water softening system for improved operation and reliability.

CAUTION

Failure to take appropriate measures to prevent scale build up can result in system failure and loss of warranty on affected parts.

Hard Water Area Map

The hard water map, shown in Figure 1-1, defines hard water areas in the continental United States which compromise fluid related components such as hoses, fittings, heaters, pumps, valves and water-cooled engines. For other countries, hard water area maps can be obtained from geological societies.

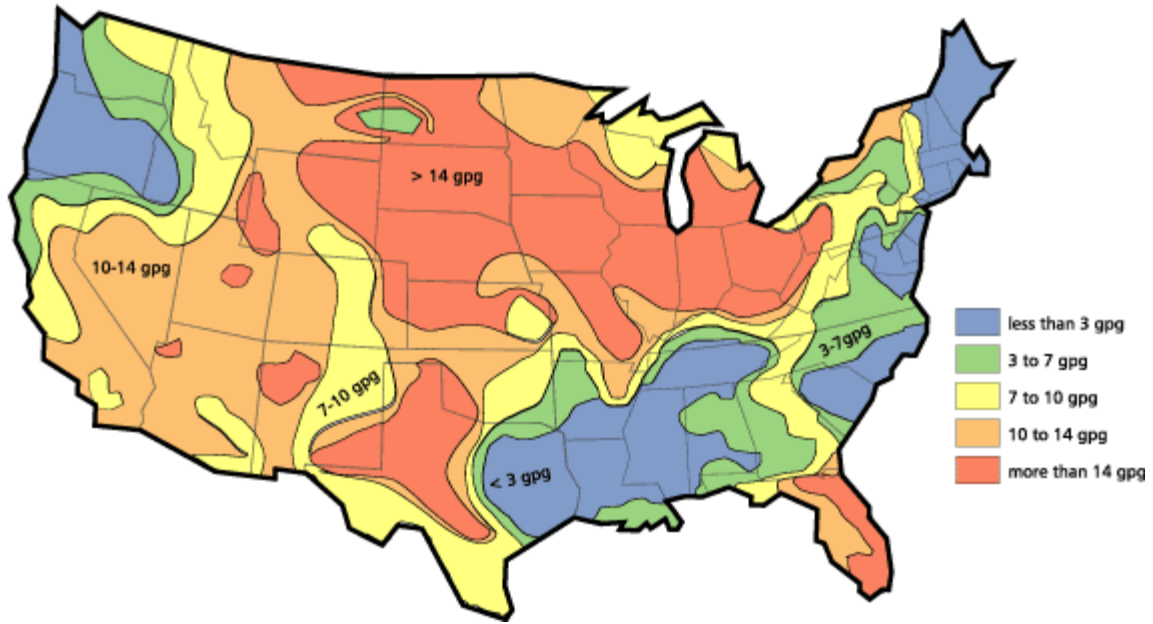


Figure 1-1. Hard Water Map of Mainland United States

NOTICE

The map shown in Figure 1-1 is provided for general reference only. Water hardness in your geographical location should be confirmed by testing.

Water Softener

Cleaning efficiency and equipment life is increased, chemical use decreased, and the appearance of cleaned carpets enhanced when water softeners are incorporated in hard water areas. HydraMaster strongly urges the use of water softener units with the CTS 403 Flex in areas exceeding 3.0 grains per gallon.

Failure to use a water softener in these areas will invalidate the machine's warranty. Referring to the hard water area map shown Figure 1-1, determine the quality of water in your area and take immediate action if the water hardness exceeds 3.0 grains per gallon.

The relatively low cost of a water softener service is more than made up for by an increased life of machine parts, reduced chemical costs and continued cleaning efficiency. The water softener will also increase the effectiveness of the cleaning chemicals, therefore less chemical will be needed.

Contact a water softener distributor in your area for information on the rental of a simple water treatment unit to carry in your truck. Be sure to charge the water softener in accordance with the capability of the softener.

For example: If the softener will treat 900 gallons of water and the machine uses an average of 30 gallons/hour, for an average of 5 hours a day, this equals 150 gallons per day). In 6 days the machine would use 900 gallons of water. Therefore, the softener would need to be charged every 6 working days for maximum softening.



Waste Water Disposal Advisory

There are laws in most communities prohibiting the dumping of recovered "gray" water from carpet cleaning in any place but a sanitary treatment system.

The cleaning rinse water, recovered into your unit's vacuum tank, contains materials such as detergents, and must be safely processed before entering streams, rivers and reservoirs.

In most cases, an acceptable method of waste water disposal is to discharge into a municipal sewage treatment system after first filtering out solid material such as carpet fiber. Access to the sanitary system can be obtained through a toilet, laundry drain, RV dump, etc. Permission should first be obtained from any concerned party or agency.

One disposal method which usually complies with the law is to accumulate the waste water and haul it to an appropriate dump site. Another solution to the disposal problem is to equip your CTS 403 Flex with an Automatic Pump Out (APO). These systems are designed to remove waste water from the extractor's recovery system and actively pump the water through hoses to a suitable disposal drain.

HydraMaster makes an APO System which can be ordered with new equipment or installed later.

When properly configured, the systems will continuously monitor the level of waste water and pump it out simultaneously with the cleaning operation. The hidden benefit of this process is that the technician does not have to stop his/her cleaning to empty the recovery tank.

NOTICE

IN ACCORDANCE WITH EPA, STATE AND LOCAL LAWS, DO NOT DISPOSE OF WASTE WATER INTO GUTTERS, STORM DRAINS, STREAMS, RESERVOIRS, ETC.

The penalties for non-compliance can be serious. Always check local laws and regulations to be sure you are in compliance.

2 - Operating Instructions

BEFORE OPERATING THE CTS 403 FLEX

NOTICE

Perform all daily and periodic maintenance as specified in Section 4 of this Owner's Manual.

1. Locate the van and equipment in a well-ventilated area.

⚠ WARNING

The CTS 403 Flex generates toxic fumes. Position the vehicle so that the fumes will be directed away from the job site. Do not park where exhaust fumes can enter a building through open doors, windows, air conditioning units or kitchen fans. If this warning is not heeded, personal injury and death can result.

2. Check the fuel tank to be certain there is adequate fuel to complete the job.
3. Connect the solution hose to the quick connect Carpet/Uph. Cleaning Solution Outlet (see Figure 2-1).
4. Connect the vacuum hose to the vacuum inlet.

NOTICE

Make sure the recovery tank drain valve is closed when operating the machine.

IN ACCORDANCE WITH EPA, STATE AND LOCAL LAWS, DO NOT DISPOSE OF WASTE WATER INTO GUTTERS, STORM DRAINS, STREAMS, RESERVOIRS, ETC.

The penalties for non-compliance can be serious. Always check local laws and regulations to be sure you are in compliance.



STARTUP PROCEDURE - CARPET/UPHOLSTERY

1. Drain Water Box.
2. Connect solution hose to Carpet/Upholstery Solution outlet and desired cleaning tool.
3. Turn the key to "Start". Pull the choke and start with the throttle in the "IDLE" position. ("IDLE" position – see Figure 2-1).
4. After the engine starts, push the choke in.
5. Adjust the throttle to full throttle.
6. Select Carpet/Upholstery Cleaning mode on the solution control switch.

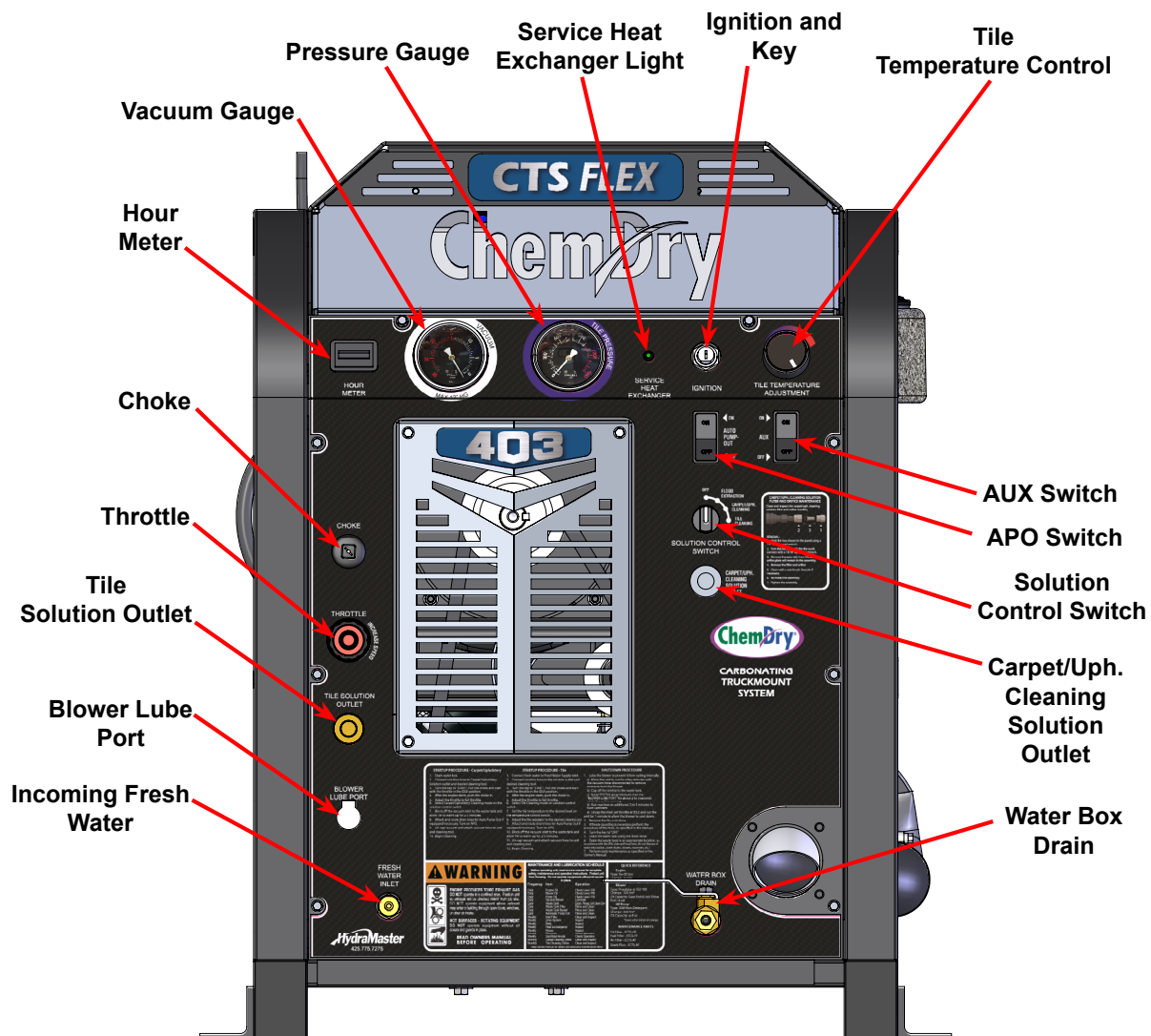


Figure 2-1. CTS 403 Flex Dash Assembly

7. Block off the vacuum inlet to the waste tank and allow TM to warm up for 2-3 minutes.
8. Attach and route drain hose for Auto Pump Out if equipped/necessary. Turn on APO.

NOTICE

The PUMP OUT system will not engage until the water level rises inside the recovery tank.

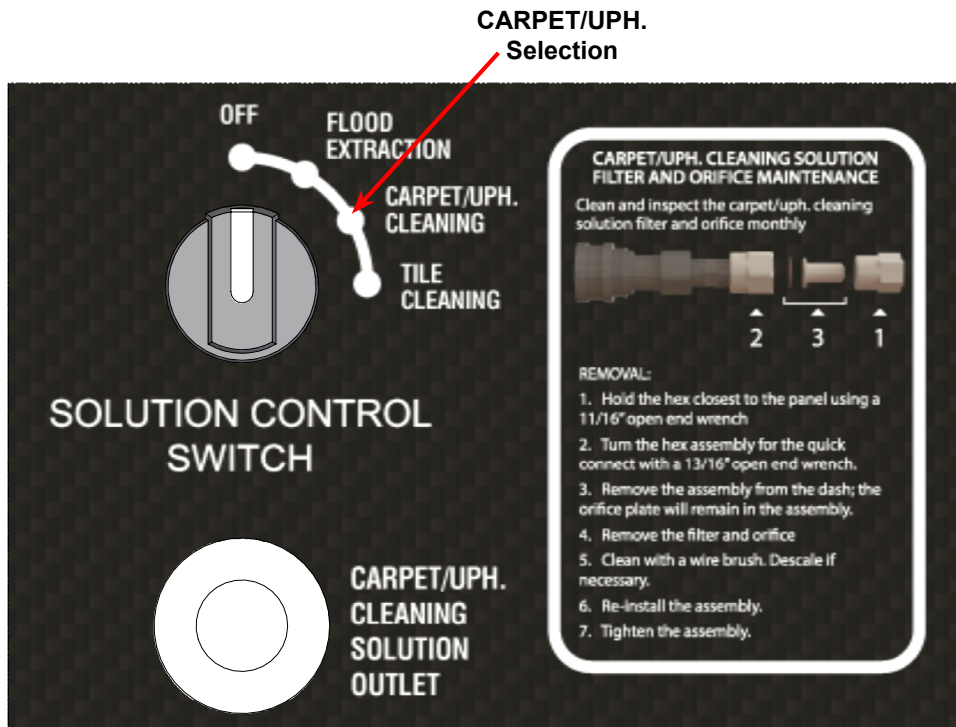


Figure 2-2. Select "CARPET/UPH." on Solution Control Switch

9. Un-cap vacuum and attach vacuum hose to unit and cleaning tool.
10. Begin cleaning.

NOTICE

The machine will automatically shut down when it reaches its full capacity due to the float switch located inside the recovery tank. When this occurs, turn the Solution Control switch to "OFF" and empty the recovery tank. Then, turn the unit back on and continue to clean.



STARTUP PROCEDURE - TILE

1. Connect fresh water to Fresh Water Supply inlet.

NOTICE

The inlet water may require a pressure reducing valve in cases where the water pressure is higher than 85 psi.

2. Connect solution hose to tile solution outlet and desired cleaning tool.

NOTICE

The water box must be full prior to starting the truckmount.

3. Turn the key to "START". Pull the choke and start with the throttle in IDLE position.
4. After the engine starts, push the choke in.
5. Adjust the throttle to full throttle.
6. Select "TILE CLEANING" on the Solution Control switch (see Figure 2-3).

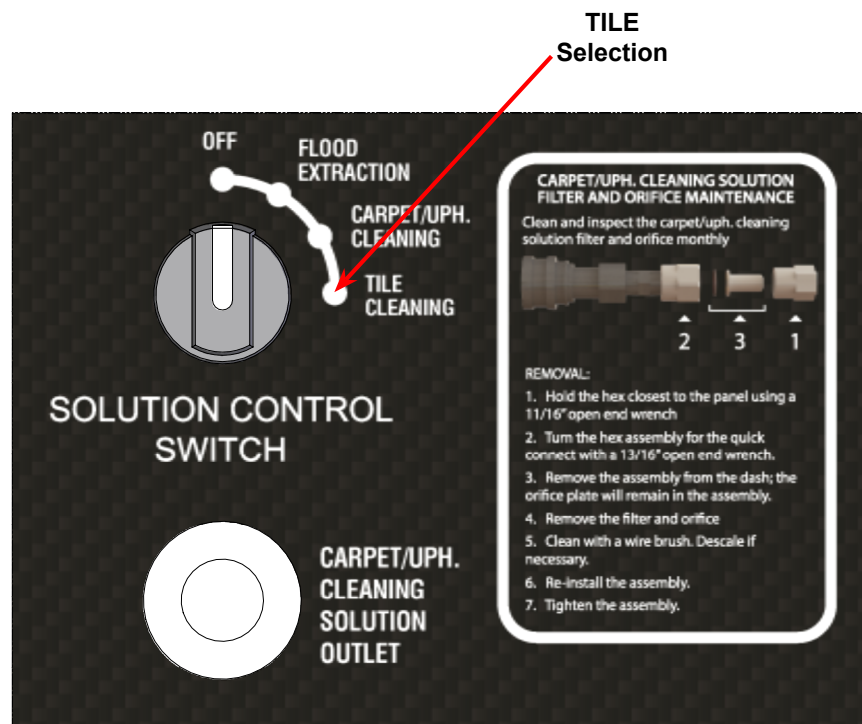


Figure 2-3. Select "TILE" on Solution Control Switch

7. Set the tile temperature to the desired level on the temperature control switch.
8. Adjust the tile regulator to the desired cleaning psi. (see Figure 2-4)
9. Attach and route drain hose for Auto Pump Out if equipped/necessary. Turn on APO.

NOTICE

The PUMP OUT system will not engage until the water level rises inside the recovery tank.



Figure 2-4. Side View of CTS 403 Flex Console

10. Block off the vacuum inlet to the waste tank and allow TM to warm up for 2-3 minutes.
11. Un-cap vacuum and attach vacuum hose to unit and cleaning tool.
12. Begin Cleaning.

CAUTION

Never perform cleaning operations when the truckmount engine is running at IDLE throttle position. Failure to follow this caution will increase the risk of serious component or engine damage.

NOTICE

The machine will automatically shut down when it reaches its full capacity due to the float switch located inside the recovery tank. When this occurs, turn the Solution Control switch to "OFF" and empty the recovery tank. Then, turn the unit back on and continue to clean.



SHUT-DOWN PROCEDURE

1. Lube the blower to prevent it from rusting internally.
 - a. Allow the unit to run for a few minutes with the vacuum hose disconnected in order to remove moisture from the blower.
 - b. Cap off the inlet to the vacuum tank.
 - c. Spray a LPS TKX spray lubricant into the "BLOWER LUBE PORT" for about 2 to 3 seconds while the unit is running (See Figure 2-1).
 - d. Run the machine an additional 2 to 5 minutes to flash off lubricant.
 - e. Uncap the inlet, set throttle at IDLE and run the unit for 1 minute to allow the blower to cool down.
2. Remove the Vacuum Hose.
3. If freeze guarding is necessary perform the procedure at this time. See Section 3, Freeze Guarding, in this Owner's Manual.
4. Turn the key to "OFF"
5. Drain the water box using the valve.
6. Drain the vacuum tank in an appropriate location.

NOTICE

In accordance with the EPA, state and local laws, do not dispose of water into gutters, storm drains, streams, reservoirs, etc.

7. Perform daily maintenance as specified in Section 4 of this Owner's Manual.

FLEX TANK OPERATION

1. Make sure the 3-way ball valve levers are all in the downward or vertical position (see Figure 2-5). The levers on the Flex pumps control the direction of the chemical flow. When the levers are in the vertical position, the flow is turned “OFF”.

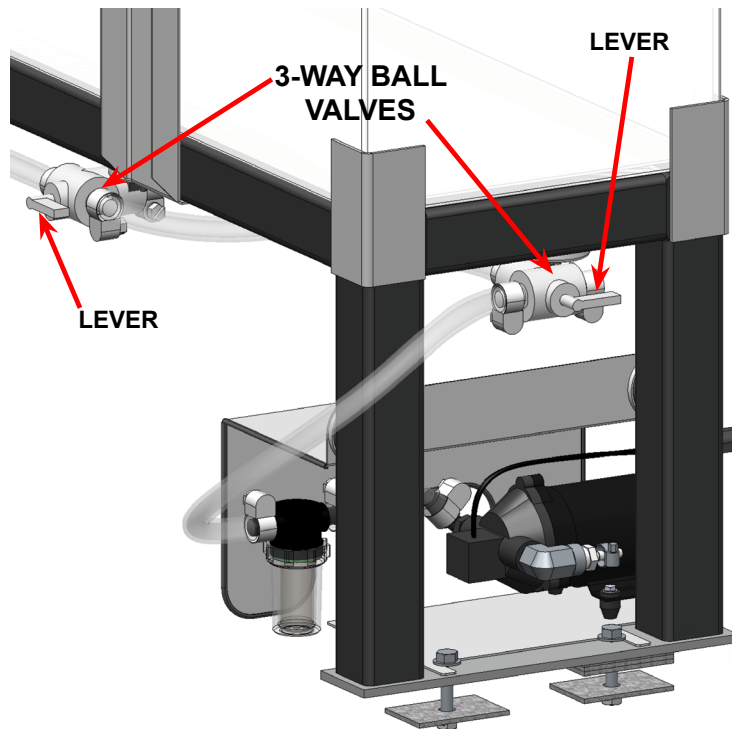


Figure 2-5. Flex Pump Levers

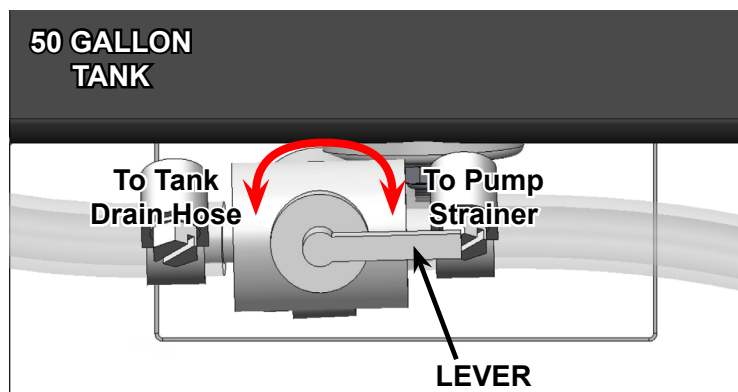


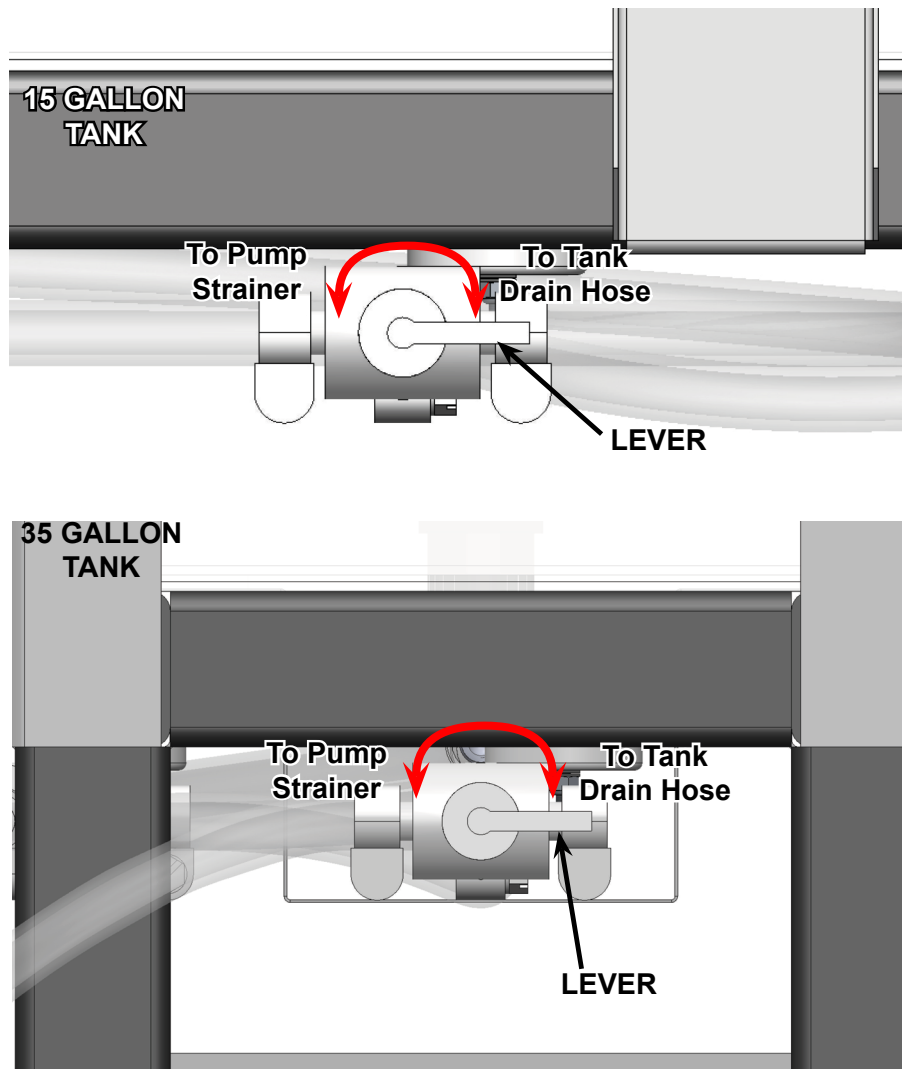
Figure 2-6. For 50 Gallon/Tank Assembly:
Turn Lever to Tank Drain Hose or in Direction of Pump Strainer

2. Open the Flex solution tank lid(s) and fill the solution tank(s) with appropriate ChemDry solution until the solution levels off below the tank vent hose hole.



There are 2 levers on the 35 Gallon/15 Gallon Tank Assembly, one for each tank (see Figure 2-5). There is 1 lever located on the 3-way ball valve on the 50 Gallon Tank Assembly (see Figure 2-6).

Before operating the Flex System, turn the appropriate lever toward the direction of the flow (toward the hose connected to the pump strainer - see Figure 2-6 and Figure 2-7).



**Figure 2-7. For 35 Gallon/15 Gallon Tank Assembly:
Turn Levers in Direction of Pump Strainer or to Tank Drain Hose**

To drain the pumps, turn the lever away from the flow.

To turn the flow off, turn the levers downward or in the vertical position.

3 - Freeze Guarding

When operating the CTS 403 Flex during the colder months of the year, ensure that you properly freeze guard the System. No part of the CTS 403 Flex is covered by warranty if machine damage occurs because of freezing.

CAUTION

BE SURE YOUR MACHINE IS PROTECTED! Freezing will cause component damage.

The following precautions are recommended prior to and during cleaning jobs:

1. Run the machine before leaving for the first job to ensure nothing has frozen the night before, including hoses and tool/wand.
2. Insulate the solution hose from the cold ground by running it through an extra 1½” vacuum hose.

NOTICE

In colder climates, insulating the vehicle walls and floor boards will help protect the unit.

Do not procrastinate during the cleaning operation or the hot water solution line will also freeze on the ground. The solution line should be insulated in extremely cold climates.

Whenever possible, store the van in a heated garage at night or over the weekend. If not possible, place a 1,500 Watt electric heater inside the vehicle, aimed directly at the machine.

⚠ WARNING

Never use a propane heater. It causes excessive moisture on the vehicle ceiling and the possibility of it malfunctioning is therefore higher, which may cause bodily injury. If the CTS 403 Flex and vehicle are left outside with a heater, drain water from the cleaning tools and hoses because they can be freeze damaged also.



FREEZE GUARDING THE CARPET/UPHOLSTERY SYSTEM

1. Connect a solution line to Carpet/Uph. Cleaning Solution Outlet with the tool of your choice attached at the end.
2. Place the tool into a container to collect the solution from the tool.
3. Pour 2 gallons of 50/50 antifreeze and water into each Flex tank.
4. Turn the ignition switch to the "ON" position.
5. Turn switch to Carpet/Upholstery cleaning and squeeze the trigger on the tool until antifreeze starts to come out of the tool.
6. Select "OFF" on the Solution Control switch.

NOTICE

Before filling the Flex tanks with chemical and starting the next cleaning job, drain the antifreeze completely from the Flex tanks and run water through the pumps until clear water drains from the machine.

NOTICE

WHEN DISPOSING OF USED ANTIFREEZE COOLANT: Follow local laws and regulations. If required, dispose at facilities licensed to accept household hazardous waste. If permitted, dispose in sanitary sewer systems. Do not discard into storm sewers, septic systems, or onto the ground.

⚠ WARNING

This warning appears on the label of one brand of antifreeze:
"HARMFUL OR FATAL IF SWALLOWED. Do not drink antifreeze coolant or solution. If swallowed, induce vomiting immediately. Call a physician. Contains Ethylene Glycol which caused birth defects in animal studies. Do not store in open or unlabeled containers. KEEP OUT OF REACH OF CHILDREN AND ANIMALS."

FREEZE GUARDING THE TILE SYSTEM

1. With the truckmount turned off and the incoming water line disconnected, open the water box drain valve on the front of the truckmount. Allow the system to fully drain.
2. Add 2 gallons of 50/50 antifreeze and water mix to the water box.
3. Attach a section of solution hose to the outgoing solution fitting on the front of the machine. Attach the opposite end to the recirculation fitting. (If more sections of hose are to be freeze guarded attach those inline.)
4. Start the truckmount and allow it to run for 2 to 3 minutes. This will distribute antifreeze solution throughout the truckmount.

NOTICE

If using the recirculation kit, skip ahead to step 6.

5. Remove the quick connect from the truckmount.
6. Spray the antifreeze and water mix out of the truckmount and into a container to reclaim the solution. Run the truckmount until there is no more solution coming from the truckmount.
7. The truckmount is now freeze guarded. Remember to flush antifreeze from the system prior to carpet cleaning. See the following procedure.

NOTICE

The reclaimed antifreeze solution may be used three times before being discarded.

NOTICE

To freeze guard the hoses and wand perform step 6 with the items to be freeze guarded attached.

Recovering Antifreeze for Re-Use

1. Attach all hoses and wands which have been freeze guarded to the truckmount.
2. Attach the incoming water source to the front of the truckmount.
3. Start the truckmount.
4. Spray the solution through the hoses and wands into a sealable container until all signs of antifreeze are gone.



Freeze Protection of the Pump-In System

1. Drain the fresh water tank.
2. Remove the garden hose adapter from the pump-in pump hose and position the hose so it is pointing outside the van.
3. Turn on the pump-in pump and run for 1-2 minutes until all the water is purged from the hose.

NOTICE

The next time the truckmount is used it may take a few minutes before the water box begins to fill.

4 - Machine Maintenance

To avoid costly repairs and down-time, it is imperative to develop and practice good maintenance procedures from the beginning. These procedures fall into daily, weekly, monthly and quarterly increments, and are outlined in this section. All recommended maintenance must be performed by competent service personnel.

This section covers:

- Operational Maintenance
- High Pressure Pump Maintenance
- Vacuum System Maintenance
- Descaling Procedure (Required)
- Tensioning the Pump Drive Belt
- Descaling Flex System as Required
- Pump Tuning Instructions
- Clean QC Filter and Orifice

NOTICE

Record the date and machine hours on the maintenance log provided for your convenience in the Owner's Guide. Records of maintenance must be kept and copies may be required to be furnished to HydraMaster before the warranty is honored. It is recommended that you affix a copy of the log on the vehicle door near your unit for convenience and to serve as a maintenance reminder.



OPERATIONAL MAINTENANCE

Daily Maintenance

- Check the engine oil level. Add oil if needed.
- Check the high pressure pump oil. Add oil if needed.
- Inspect and rinse the recovery tank.
- Leave lid open to allow moisture to evaporate.
- Inspect and clean the recovery tank filters.
- Inspect and clean the orifices and filters.
- Inspect and clean the garden hose screen.
- Inspect the truckmount for water and oil leaks, loose electrical connections, etc. and repair as needed.
- Lubricate the blower lube port with HydraMaster-recommended spray lubricant.

Weekly Maintenance

- Inspect the recovery tank filters for tears, holes, etc. Repair or replace as needed.
- Inspect the sacrificial anode assembly in the tank and repair and replace as needed.
- Inspect the vacuum relief valve. Clean and lubricate as necessary.
- Clean the recovery tank thoroughly with pressure washer.
- Check the oil level in the blower. Add oil if needed.
- Check the pump drive belt for wear and proper tension. Tighten as needed.
- Check all the hoses and wiring for wear and chafing. Secure as needed.
- Flush the water and chemical systems with solution of equal parts white vinegar and water.
- Check all the nuts and bolts. Tighten as needed.
- One time change of the high pressure pump oil after 50 hours of operation. (Every 500 hours thereafter.)
- One time change of the engine oil after 8 hours of operation.
- Change the engine oil every 50 hours. (Every 25 hours if operating in high ambient temperatures or heavy use conditions.) Change oil filter every oil change.

Monthly Maintenance

- Check the engine air filter. Clean or replace as necessary.
- Check the water level in battery. Fill as needed.
- Clean the battery terminals as needed.
- Change the blower oil after first 100 hours of use.
- Clean the QC filter and orifice with water.
- Check and lube inlet valve in the water box with Super Lube grease #92003 or equivalent (or every 100 hours).

Quarterly Maintenance

- Check the fuel lines. Repair or replace as needed.
- Gap the spark plugs to 0.030". Replace if excessive carbon buildup is visible.
- Change the fuel filter.
- Change pump drive belt.

250 Hours

- Check coupler (rubber sleeve) for cracks or wear. Replace as necessary.

500 Hours

- Change the blower oil.
- Change the high pressure pump oil.
- Check the engine valve clearance (intake and exhaust 0.004" - 0.006")
- Change the fuel filter.
- Check coupler (rubber sleeve) for cracks or wear. Replace as necessary (Coupler Sleeve Part Number: 000-152-015).

1000 Hours

- Change air filters.
- Check carburetor. Clean or replace as necessary.
- Clean the heat exchanger core.
- Check coupler (rubber sleeve) for cracks or wear. Replace as necessary (Coupler Sleeve Part Number: 000-152-015).

NOTICE

Refer to the Interval Hours Maintenance chart in the Owner's Guide.



HIGH PRESSURE PUMP MAINTENANCE

Daily

Check the oil level and the condition of the oil. The oil level should be up to the center of the sight glass on the rear of the pump or between the "MIN" and "MAX" lines on the dipstick. The dipstick may be found by removing the oil cap.

Periodically

Change the oil after the initial 50 hours of operation and every 500 hours after that. It may be necessary to replace the pump seals and check valves at 500 hours if the truckmount has been running in high ambient temperatures.

CAUTION

If the oil becomes discolored or contaminated one of the oil seals may be damaged. Do not operate the pump if the crankcase oil has become contaminated. Do not rotate the drive shaft without oil in the crankcase reservoir.

CAUTION

The pump should never be run dry. Running the pump dry will cause premature wear on the seals, packing and plungers. Running the pump dry for a prolonged period of time may cause damage that cannot be repaired and voids warranty.

CAUTION

Do not run the pump with frozen water in the manifold. If there is a risk of freezing, freeze guard the truckmount. See section 3 for freeze guarding information.

Service

The next few pages explain how to disassemble and inspect all user serviceable parts of the pump.

CAUTION

Do not disassemble the pump unless you are a skilled mechanic. For assistance, contact your distributor.

Valve Maintenance (See Figure 4-1)

1. Using a 22-mm wrench or socket, remove all six valve caps on the manifold of the pump.
2. Examine each valve cap O-ring for cuts or distortions and replace if worn.
3. Using needle nose pliers, remove the suction and delivery check valves. The valve assembly usually stays together when removing. If the valve comes apart, use the needle nose pliers or reverse pliers to remove the remaining parts.
4. Inspect each suction and delivery check valve assembly for wear and pitting, and replace if necessary. The valve assembly consists of the plastic cage, spring, valve seat, poppet and O-ring. One valve kit is needed for complete valve change of one pump.

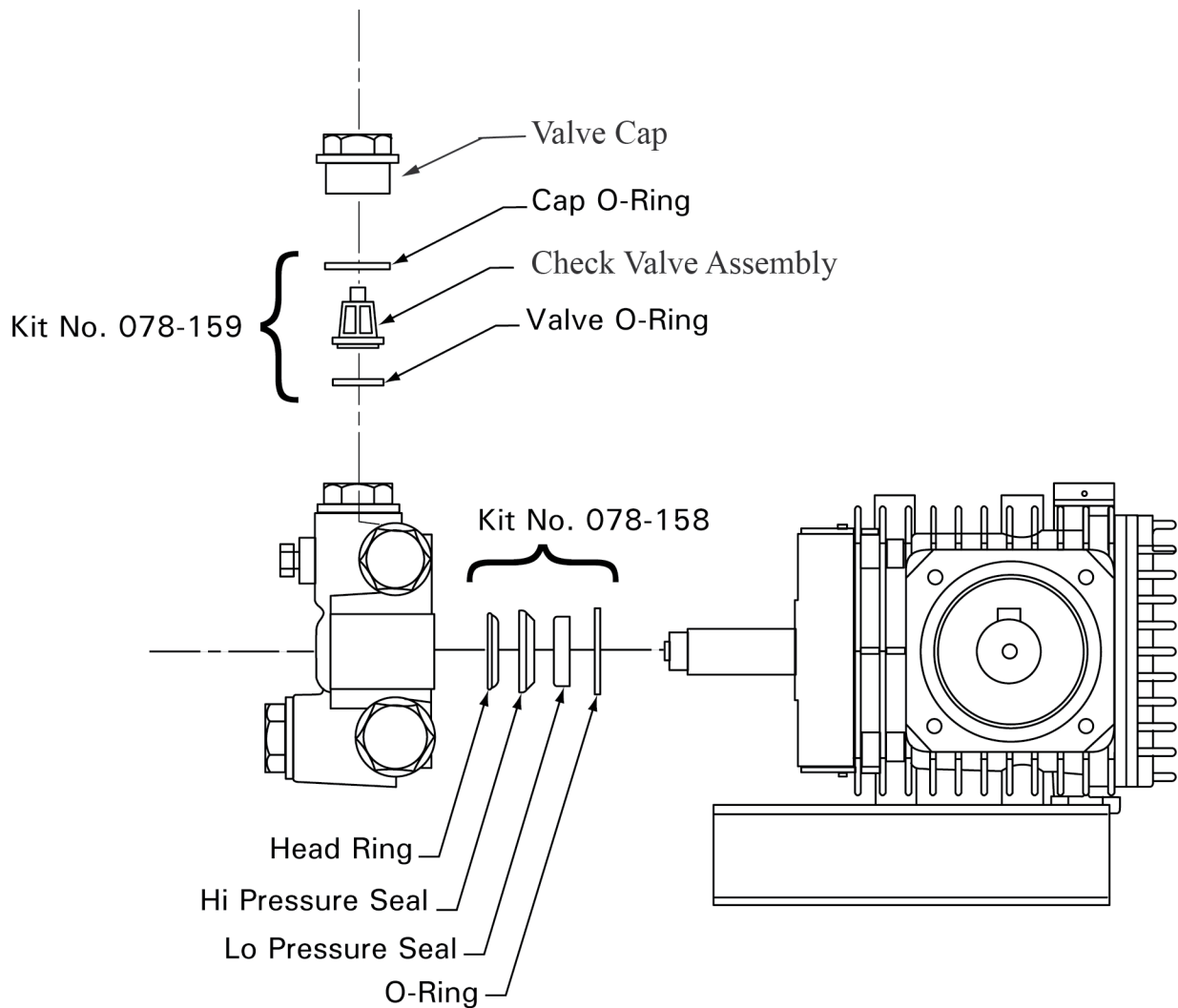


Figure 4-1. Servicing the Valves



5. Replace old valves with new valves by placing the assembly in the valve chamber. Press down firmly on the top of the valve assembly.
6. Replace valve caps by applying LOCTITE® 243 to valve cap and torque to 33 ft-lbs.

Removing and Replacing Pump Manifold

1. Remove the manifold of the pump by taking a 5-mm Allen head wrench and removing the eight head bolts.
2. With the pump firmly secured, take a medium sized flat head screwdriver and apply pressure to the manifold by prying between the crankcase and manifold. Work around from all sides of the manifold evenly until it comes off of the pistons. Keep the manifold properly aligned with the pistons to prevent damage to the seals and pistons.
3. When replacing the manifold, turn the crankshaft of pump until the top of the pistons are closely aligned. Lubricate the pistons and cylinders with grease and evenly press the manifold toward crankcase until flush.

Seals and V-Packing Maintenance

1. Remove the manifold as previously described. It is possible that the seal and brass retainer ring assembly will stay on the piston or will remain in the manifold when removing it.
2. Carefully remove the brass retainer ring/seal stack. Remove the low-pressure seal using needle nose pliers. Discard the old seal.
3. Remove the outer O-ring by taking a small flat head screwdriver and working it under the O-ring. Simply roll off the old O-ring and discard.
4. The old V-packing stack can be taken apart by hand and discarded.

Seals and V-Packing Reassembly

1. Generously lubricate parts with grease when reassembling. Examine all brass components for any damage or water residue build-up. Clean or replace as needed.
2. Insert a new low pressure seal by working it in by hand.
3. Install the new outer O-ring by simply starting on one side and working it into the groove.
4. Stack the new V-packing in the correct order and firmly press the assembly into the manifold.
5. Install a new low pressure oil seal by laying the seal into the opening and evenly pressing it into place.
6. Re-install the manifold onto the pump as previously described.

Plunger Maintenance

1. Remove the manifold as previously described. Remove the packing retainers if they remain on the pistons after removing the manifold.
2. Remove the nut and washer on the end of the piston using a 13-mm wrench or socket.
3. Slide the ceramic plunger and the remaining washer from the piston guide. Inspect the ceramic piston, O-ring and washers for wear. Replace if necessary.

Plunger Re-assembly

1. Generously grease the piston guide. Replace the O-ring making sure it does not twist or roll.
2. Slide the lower washer and ceramic bushing onto the piston guide.
3. Place a small amount of LOCTITE 243™ on the piston guide threads. Replace the old washer and thread the nut onto the piston guide. Torque to 4.5 ft-lbs.

Servicing the Crankcase

1. While the manifold and plungers are removed, rotate the crankshaft by hand. Closely examine the crankcase oil seals for drying, cracking or leaking.
2. Consult the local HydraMaster distributor if crankcase servicing is necessary.

VACUUM SYSTEM MAINTENANCE

The vacuum pump in this machine is commonly referred to as a “rotary positive displacement blower” or “blower” for short. The performance and life of the truckmount is greatly dependent on the care and proper maintenance it receives. Review the blower’s owner’s manual, which has been included, for a better understanding of this piece of machinery.

To protect the blower from overloading and damaging itself, a vacuum relief system is installed on the recovery tank. When the recovery tank inlet is completely sealed off, a maximum of 12” Hg will be attained.

Adjusting the Vacuum Relief Valve

1. Turn the two brass knurled nuts opposite directions so the inside nut turns freely. (Two brass knurled nuts are located on the side of the recovery tank - see Figure 4-2.)
2. Increase the vacuum of the system by turning the nut clockwise (tightening).
3. Decrease the vacuum of the system by turning the nut counter-clockwise (loosening).
4. Once the tank is set to the proper level, turn the two brass nuts toward each other to lock them down.
5. Always verify the final setting before locking adjusting nut.

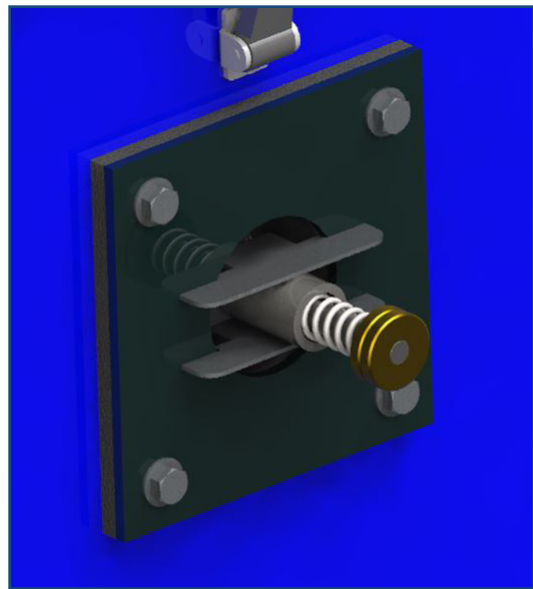


Figure 4-2. Adjusting Vacuum Relief Valve

CAUTION

Solid objects entering the blower will cause serious damage to the internal components of the blower. Extreme caution should be used when the truckmount is being run for test purposes with the inlet to the blower open to the atmosphere.

CAUTION

Foam passing through the blower can lead to serious problems with the truckmount. It is important to keep the recovery tank free of foam. The tank is protected from overflowing by a float kill switch; however, this switch is not activated by foam.



Daily

At the end of each day the internal components of the blower need to be lubricated. This helps to prevent rust deposits and prolongs the life of the truckmount.

Lubricate the blower to prevent it from rusting internally by:

- a. Allow the unit to run for a few minutes with the vacuum hose disconnected in order to remove moisture from the blower.
- b. Cap off the inlet to the vacuum tank.
- c. Spray a LPS TKX spray lubricant into the "BLOWER LUBE PORT" for about 2 to 3 seconds while the unit is running.
- d. Run the machine an additional 2 to 5 minutes to flash off lubricant.
- e. Uncap the inlet, set throttle at IDLE and run the unit for 1 minute to allow the blower to cool down.

Periodically

Change the oil in both ends of the blower after the initial 100 hours of use. Change the oil each 500 hours of use thereafter.



DESCALING PROCEDURE -TILE

Scale deposits on the interior of the heating system can cause a noticeable loss in heating performance. Deposits of this kind result from hard water deposits. The frequency with which descaling procedures are required will vary. If the area has particularly hard water, you may have to descale often.

To descale the system, add an appropriate descaler chemical to the water box. Circulate it through the system. Let it stand. Flush and repeat as necessary. Clean all screens and strainers, and check them frequently following descaling.

NOTICE

If using TM DeScaler™ through the flow meter, make sure to run clean water through the flow meter after this procedure.

To descale using the recirculation kit (P/N 000-078-058), start with an empty water box.

1. Fill a third of the water box with TM DeScaler. Follow the recommendations on the TM DeScaler label for proportions. Verify that the float is not lying horizontal, but floats below.
2. Attach the recirculation fitting provided in the kit to the garden hose quick connect (see Figure 4-3) and this combination to the front of the truckmount.
3. Attach one section of the solution hose to the outgoing solution fitting on the front of the truckmount and the other end to the garden hose and recirculation fitting combination that is attached to the front of the truckmount. Additional hoses may be attached inline if descaling of hoses is needed.
4. Start the truckmount and allow it to run for 3 - 5 minutes. Do not leave the TM DeScaler solution in the system. Flush the system with clean water and turn the truckmount OFF.

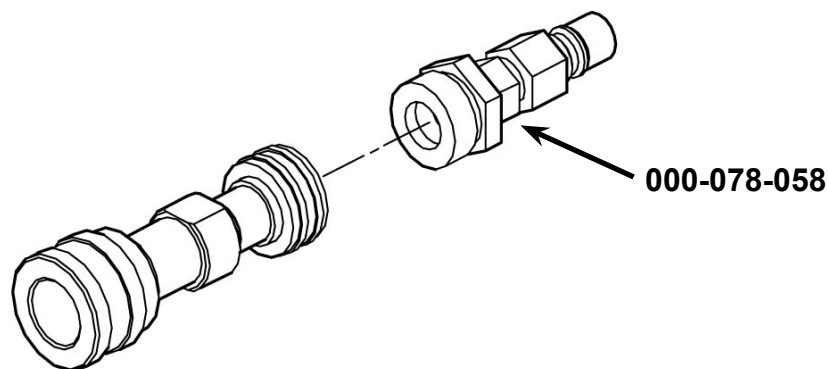


Figure 4-3. Recirculation Fitting

DESCALING PROCEDURE - CARPET/UPHOLSTERY

1. Connect a solution hose to the Carpet/Uph. Cleaning Solution Outlet.
2. Route the other end of the solution hose to the Flex tank.
3. Attach an open quick connect to the other end of the hose.

NOTICE

The descaler will drain from the female QC fitting assembly/hose quickly. Have extra buckets ready to swap out because each bucket should fill quickly.

4. Pour 5 gallons of descaler solution into each of the Flex tanks.
5. Turn the ignition switch to the "ON" position.
6. Select "CARPET/UPH." on the Solution Control switch.
7. Add water to the Flex tank to flush all descaler out of the solution line.
8. Select "OFF" on the Solution Control switch.



TENSIONING THE PUMP DRIVE BELT

1. Remove the CTS 403 Flex grill to gain access to the idler pulley.
2. Loosen but **do not remove** the 2 ½" long bolt (P/N 000-143-716) on the idler pulley. See Section Owner's Manual.
3. Remove the right cover of the machine to gain access to the tensioning screw.
4. Adjust the tension of the belt by turning the 4" long screw (P/N 000-143-376).
5. After the proper belt tension is achieved, tighten the ½" bolt on the idler pulley.

CAUTION

Ensure there is no contact between idler assembly (including belt) and no other part of the truckmount. Contact between the parts could result in damage to the truckmount.

6. Replace the right cover and grill.

PUMP TUNING INSTRUCTIONS

Pump tuning for the CTS 403 Flex allows the pump pressure switch to turn off when there is no flow out of the tool. This reduces the pump operating temperatures and increases the pump durability.

NOTICE

Pump tuning should be performed every 60 days.

The pump pressure setting adjustment is performed by turning the hex screw, which is close to the center of the pump head, with a hex L-key, provided in the Flex Installation Kit - (see Figure 4-4).

- Clockwise increases the pressure
- Counterclockwise decreases the pressure.

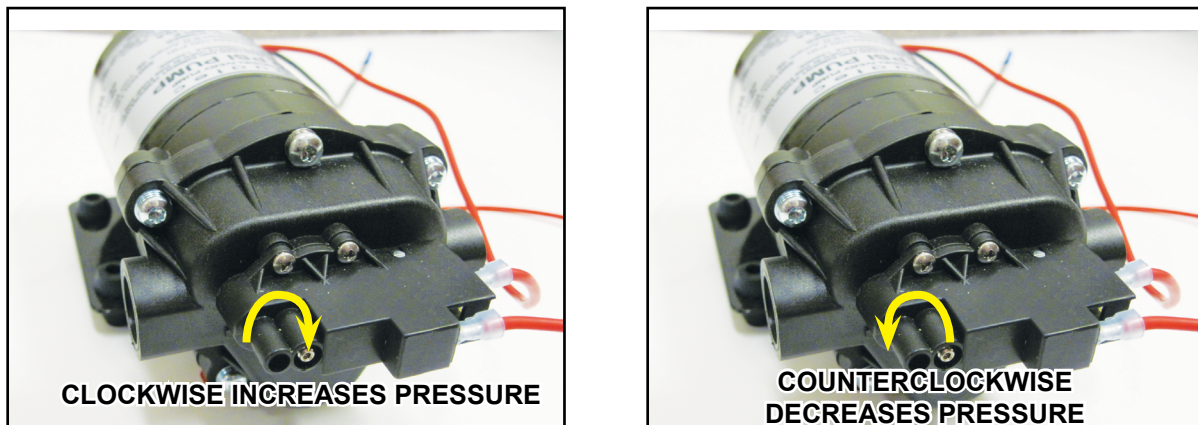


Figure 4-4. Location of Pump's Hex Screw

Tools required include:

- 1/16" hex L-key (one is provided with each pump for your convenience in Installation Kit, P/N 000-078-934).
- Solution hose
- Cleaning tool (upholstery tool/ wand/ rotary cleaning tool) to allow solution to flow out
- Container to collect solution flowing out of the tool.



Start-up Pump Tuning Procedure

1. Connect the tool's solution hose to the quick disconnect.
2. Turn the ignition switch to the "ON" position.

NOTICE

You do not need to start the unit since vacuum is not needed for this procedure.

3. Select "CARPET/UPH." on the Solution Control switch.
4. With the pump still on, disconnect the solution hose from the Flex unit.

The pump should run for about 3 to 5 seconds and then switch off.

5. Leave the hose disconnected.

Continue on to the Adjustment procedure (page 4-17).

Adjustment

1. If the pump continues to run for longer than 3 to 5 seconds, turn the screw counterclockwise until the pump switches off (see Figure 4-5).
2. If the pump switches off as soon as the hose is disconnected (less than 3 to 5 seconds), turn the pump screw clockwise one complete turn.
3. With the pump still on, reconnect the solution hose onto the Flex unit (see Figure 4-4).

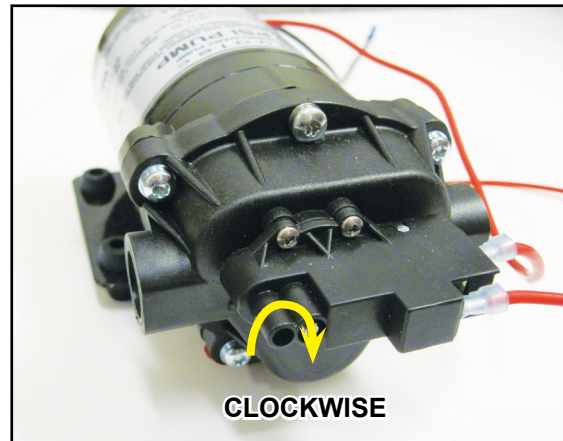
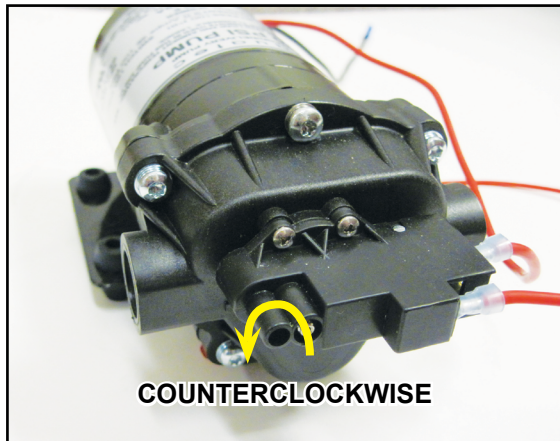


Figure 4-5. Insert Hex L-Key and Turn It Counterclockwise/Clockwise

The pump should switch on.

4. Repeat steps 1 through 3 on this page until the pump switches off within 3 to 5 seconds after the hose is disconnected.



CLEAN QC FILTER AND ORIFICE

Clean and inspect the in-line quick connect filter and orifice every 100 hours.

1. Remove the quick connect assembly on the Carpet/Uph. Cleaning Solution Outlet (see Figure 4-6).
2. Hold the hex closest to the panel using a 11/16" open end wrench and turn the hex assembly for the quick connect with a 13/16" open end wrench.
3. Remove the assembly from the dash; the orifice plate will remain in the assembly.



Figure 4-6. Remove Quick Connect Assembly

4. Remove the filter and orifice (see Figure 4-7).
5. Clean with a wire brush. Descale if necessary.
6. Re-install the assembly.
7. Tighten the assembly.

NOTICE

The amount of torque may vary. Run the pump to verify there are no leaks. Re-tighten as required.

NOTICE

The assembly may move in the dash during removal and installation. This is normal; using the 11/16" wrench will minimize the movement.

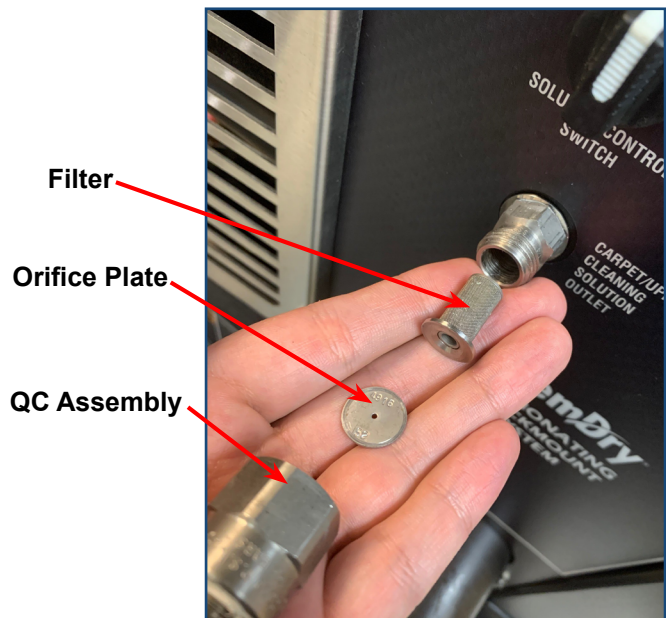


Figure 4-7. Remove Filter and Orifice

SERVICE HEAT EXCHANGER INDICATOR - CTS 403

The engine backpressure is measured at a small port on the inlet plenum of the heat exchanger assembly. The exhaust of the blower and engine combine at the plenum and represents the most accurate pressure reading for the engine exhaust.

It is the combination of these two systems that is being monitored by the pressure switch, located on the right-hand side of the machine with the other relays and fuses. The pressure switch and light are designed to measure the backpressure of the heat exchanger as an indicator of potential clogging due to chemical build up, carbon, and other debris. When the level of backpressure reaches the maximum safe upper limit, a continuous red SERVICE HEAT EXCHANGER light on the dash will indicate a need to inspect and possibly clean out the heat exchanger assembly. This can be easily accessed through the removable plate on the left-hand side of the unit. Removing the access plate on the right side and shining a flashlight through from this side to the left side will show if there is blockage and the level of cleaning required.

The pressure switch is calibrated at a level that will register at the correct backpressure range, with a recovery tank connected to the machine. Due to the nature of backpressure switch and measuring it from the location, a flickering of the SERVICE HEAT EXCHANGER light might occur at very low levels of pressure, and approximately 4" Hg is required at a minimum. Sudden changes in pressure during the use of the machine might also cause a flickering of the indicator light. Though it is never a bad idea to check the condition of the heat exchanger core, a continuously lit red SERVICE HEAT EXCHANGER light will indicate a necessary investigation.

It is recommended to clean the heat exchanger core using an air conditioning coil fin comb and an aerosol foam no rinse coil cleaner, warm and soapy water, isopropyl alcohol, or other method using the access ports on the sides of the assembly. After cleaning out the heat exchanger, verify the backpressure system is working properly before returning the unit to work duty.

During the cleaning process, be aware of the debris flooded through the heat exchanger might be blown out of the assembly and into the surroundings. To minimize the potential for spraying water, cleaning solution etc. reinstall port plate on the right side prior to cleaning. Collect dirty water and chemical residue that comes out of the heat exchanger, exhaust, or silencer. If water was used, run the unit after cleaning long enough for any water that collected in the silencer to be heated to vapor and passed through the system. Water in the silencer might rust and prematurely degrade the component, leading to failure.

It might be necessary to remove the entire heat exchanger assembly and disassemble the cores for a more thorough tank soak. It is recommended to do this every 1000 hour of the machine operation and might be required more frequently depending on how clean the core can be kept using the access ports, machine use, type of cleaning, and other factors.



CLEANING OUT THE HEAT EXCHANGER OF THE CTS 403

During routine maintenance, and when the SERVICE HEAT EXCHANGER light is a continuous red during operation, access to the heat exchanger assembly can be made by removing the cover plates of the plenum. With the unit off, use a 5/16" nut driver or socket to remove the left side panel of the inlet plenum. Remove the gasket underneath the plate to expose the heat exchanger core.

The inlet side will collect debris like hair and carpet fiber, as well as engine carbon and chemical residue. Using a radiator comb or similar brush, remove loose debris and clear it from the heat exchanger.

Remove the second heat exchanger access plate from the right side of the unit and check the condition of the core. With both plates and gaskets removed, a bright light can be used to shine on one end and should be visible through the core's veins. If not, or if chemical and other debris is visible in the outlet side of the plenum, the heat exchanger should be cleaned out with warm, soapy water, isopropyl alcohol, or other method.

Protect the van and the rest of the machine from debris by replacing one side cover of the plenum access port and using low pressure to clean the core. Remove as much fluid and residue as possible before replacing both cover plates and testing the unit's backpressure. Run the machine long enough to vaporize any water or other cleaner that might have collected in the silencer, as any residual water in the silencer can result in rusting and component failure.

It is highly suggested that a routine deep cleaning be performed every 1000 hours of use. Very carefully remove the entire heat exchanger assembly from the machine, remove all components and covers, and use a high-quality degreaser. It is recommended to check the status of the soaking cores every few hours to ensure that there is no danger of premature structural degradation or long-term damage. This method of deep cleaning might take as long as overnight to get the best results.

Some recommended types of cleaning products are:

- Coli Safe Professional Grade Neutral pH Evaporator and Condenser Cleaner
- Air Conditioner Coil Foam Cleaner
- Evap Foam No Rinse Evaporator Coil Cleaner

5 - Solution Flow Paths

This section shows the high and low pressure flow diagrams.

Figure 5-1. Flow Diagram - View 1 of 2
000-179-856 Rev. A

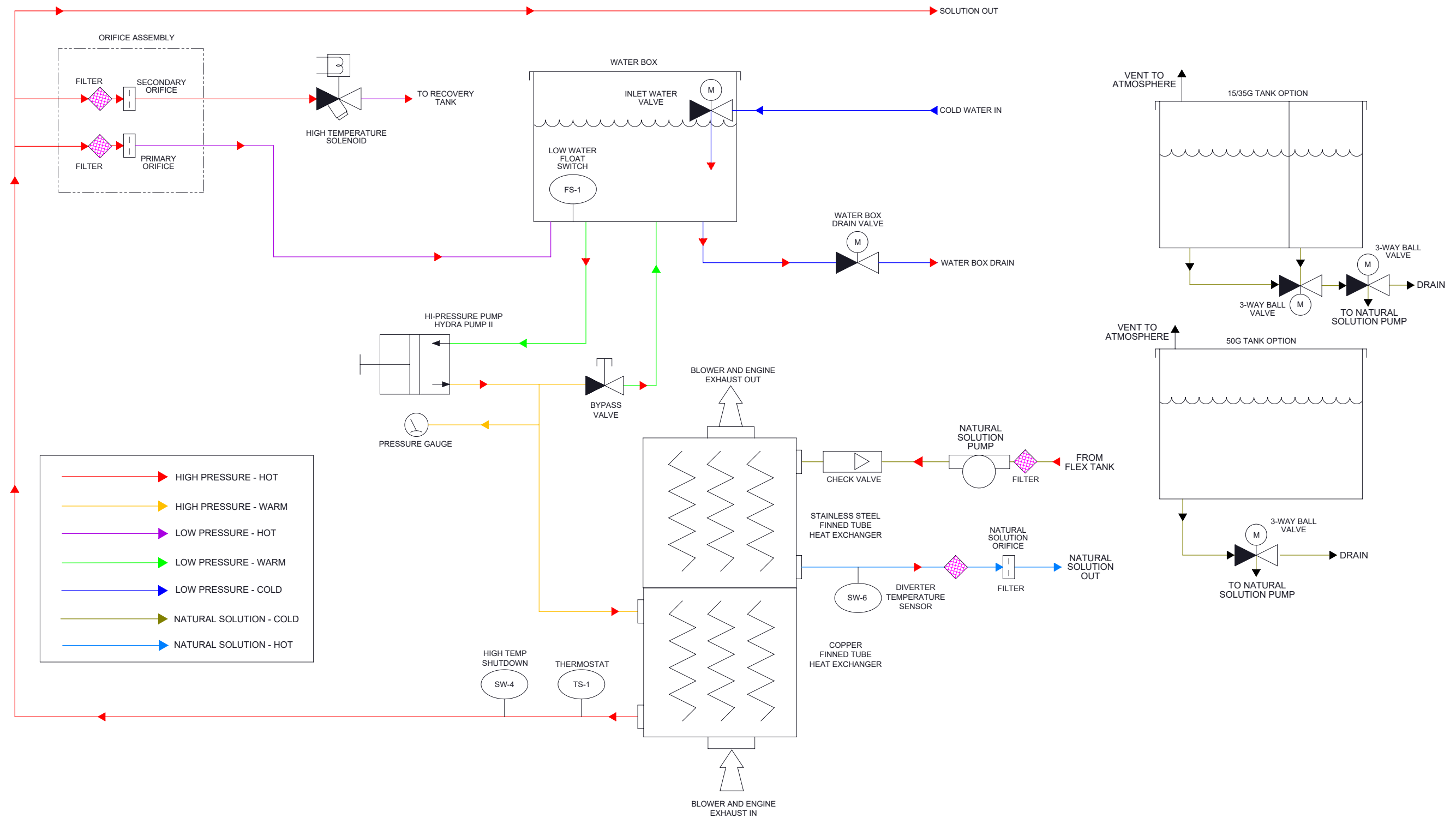
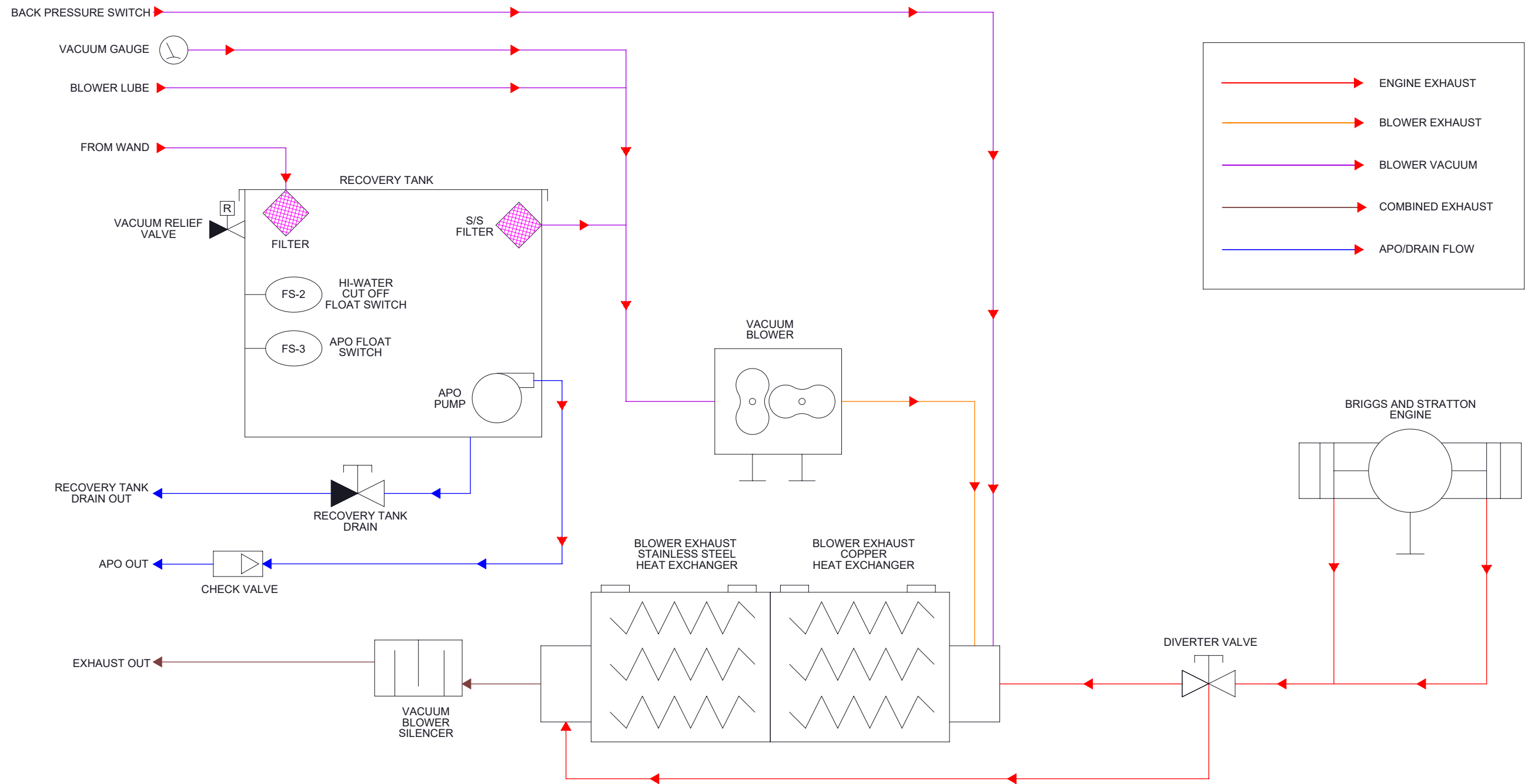




Figure 5-2. Flow Diagram - View 2 of 2
000-179-856 Rev. A



6 - Electrical System

This section describes how the electrical system functions in the following manner:

- Electrical System Information
- Electrical Schematic
- Wiring Diagram

The CTS 403 Flex electrical system operates on 12 V DC which is provided by the battery. Battery levels are maintained by a 20 Amp alternator that is built into the engine.

NOTICE

When a new battery is installed, check that it is properly charged before installation or damage to the charging system may occur.



Figure 6-1. Electrical Schematic
000-179-855 Rev. A

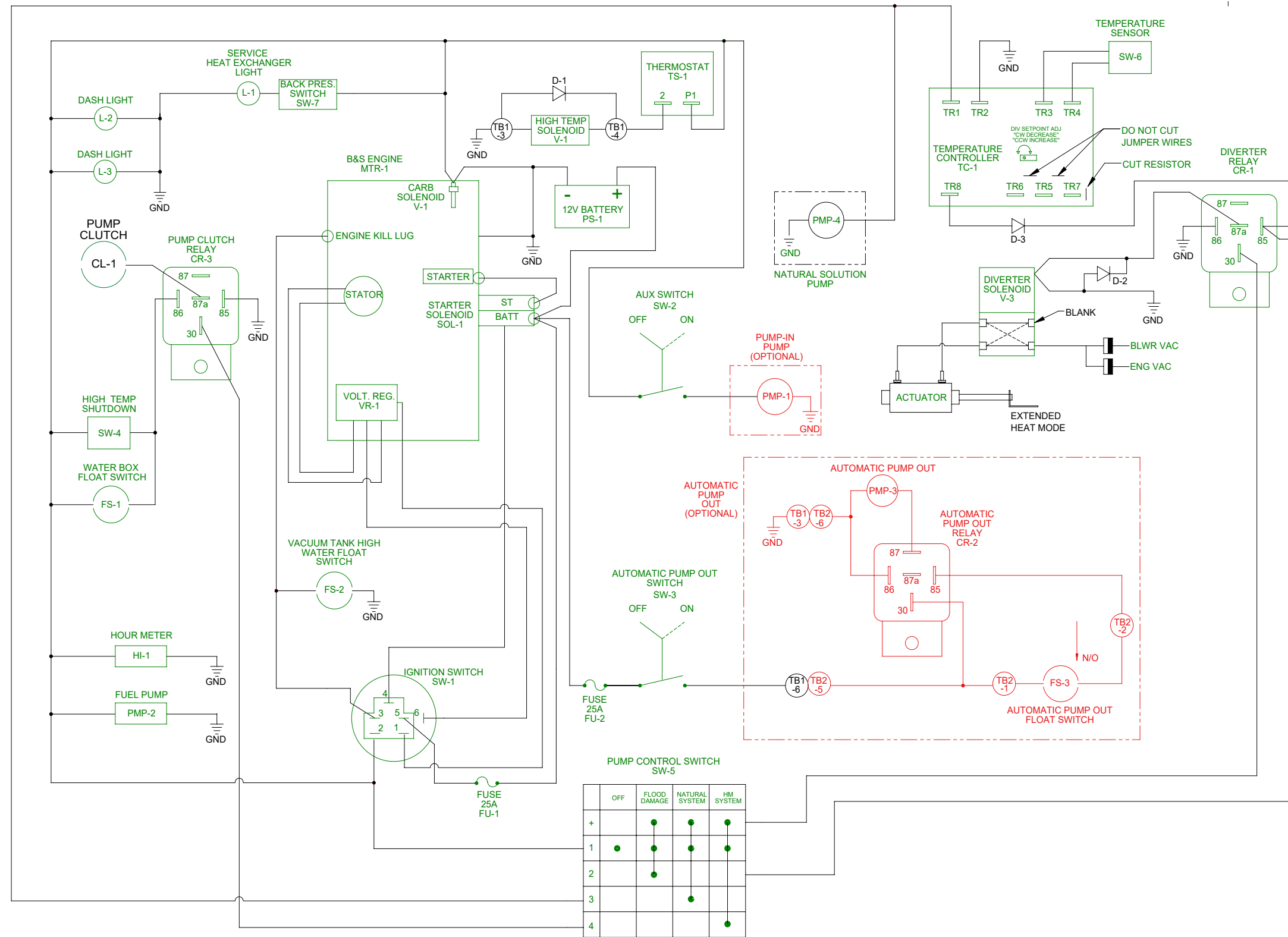


Figure 6-2. Wiring Diagram - View 1 of 2
000-179-854 Rev. B

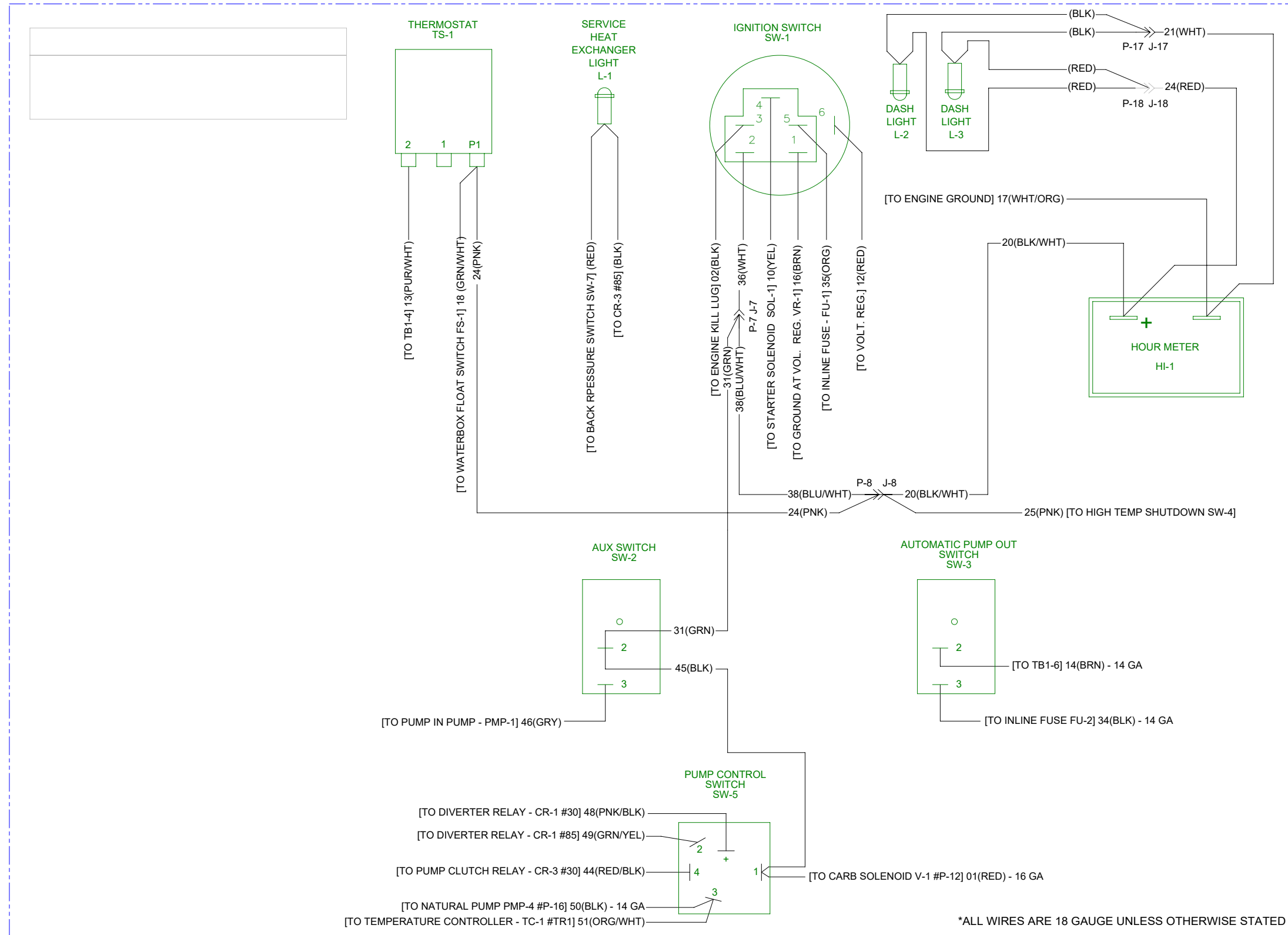
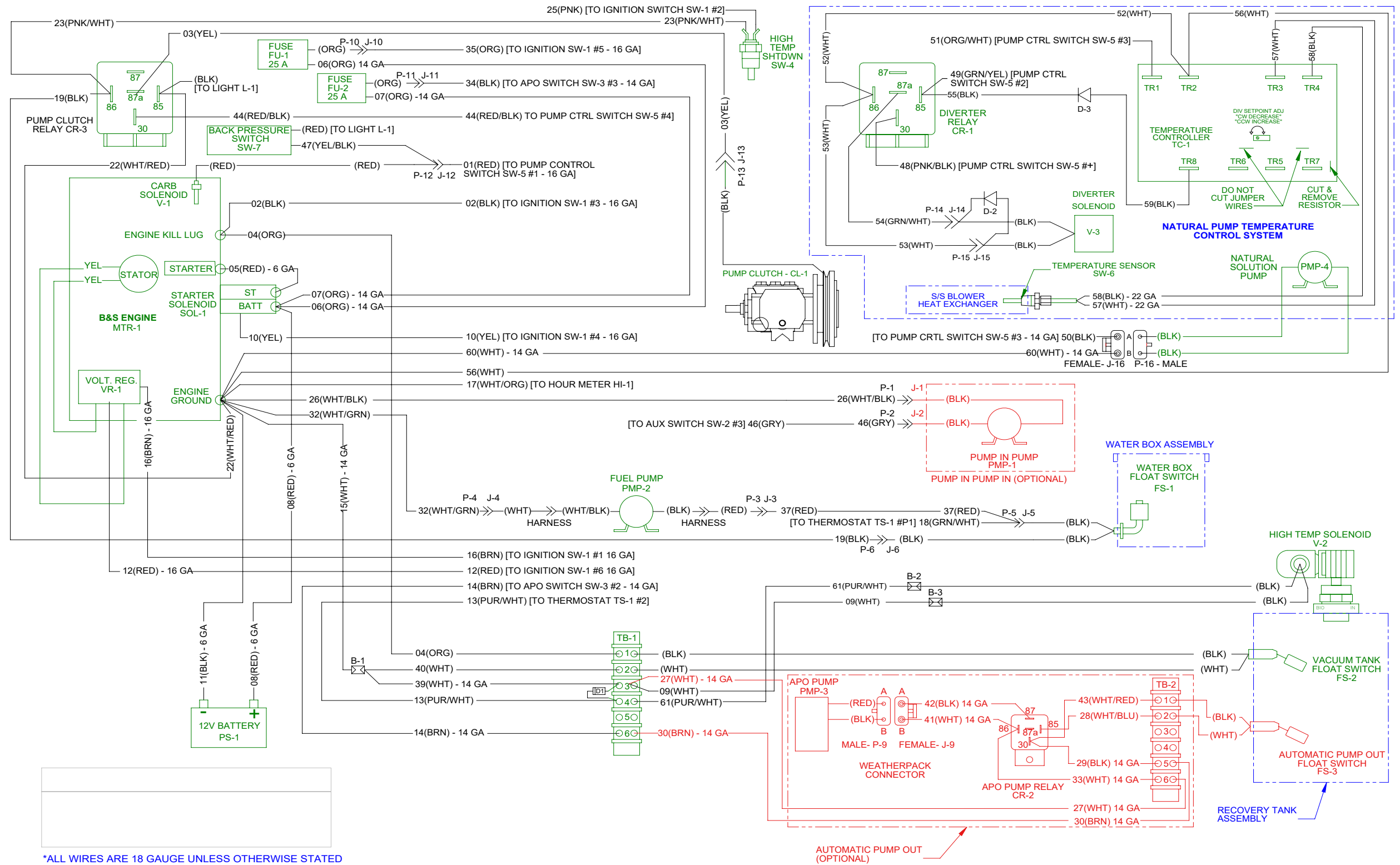




Figure 6-3. Wiring Diagram - View 2 of 2
000-179-854 Rev. B



7 - Troubleshooting

This section describes the standard troubleshooting procedures in the following areas:

- Heating System
- Engine
- Tile System
- Carpet/UPH System
- Vacuum System



HEATING SYSTEM

1.0 Truckmount overheats and shuts down

	Possible Cause	Solution
1.1	The tile orifice or filter screen are restricted.	Remove and inspect. Clean as necessary.
1.2	The tile dump solenoid is restricted.	Inspect the solenoid and the hose that delivers water to it. Clean or replace as necessary.
1.3	The tile dump solenoid is faulty.	Check the main fuse. If the fuse is blown, inspect electrical system for worn or shorted wires. Repair or replace as necessary.
		Inspect the solenoid and test for functionality. If the solenoid is operable, refer to a qualified service technician to test the temperature controller and sensor.

2.0 Unable to achieve normal cleaning solution temperature

	Possible Cause	Solution
2.1	Tile temperature control knob is turned down.	Inspect the knob. Adjust if necessary.
2.2	The tile dump solenoid is faulty.	Inspect the solenoid and test for functionality. If the solenoid is operable, refer to a qualified service technician to test the temperature controller and sensor.
2.3	Excessive solution flow at tool.	The cleaning tool jet is too large or worn. Inspect the jet. Replace if necessary.
2.4	The heat exchanger has hard water scale buildup.	Descale the system.
2.5	The heat exchanger has blockage on the exhaust side.	Inspect the interior of heat exchanger. Remove the debris and clean as necessary.

ENGINE

1.0 Will not turn over

	Possible Cause	Solution
1.1	A loose or corroded battery terminal.	Clean and tighten the battery terminal connections.
1.2	The battery is dead.	Recharge or replace the battery. Test the charging system. Repair if necessary. <div style="background-color: yellow; text-align: center; padding: 5px;">CAUTION</div> <p>Do not attempt to jump start the truckmount from a running vehicle. The amperage output from an automobile will damage the charging system of the truckmount.</p>
1.3	The main fuse is blown.	Check the main fuse.
		If the fuse is blown, inspect the electrical system for worn or shorted wires. Repair or replace as necessary.
1.4	The vacuum blower has seized.	Attempt to turn the coupler by hand. If it will not turn refer to the Vacuum System Troubleshooting Section.
1.5	The ignition switch is faulty.	Test to see if there is power both to and from the switch. Refer to the Electrical Section.
1.6	The starter solenoid is faulty.	Test to see if there is power to solenoid with ignition in "Start" position. Refer to Electrical Section.
1.7	The starter motor is faulty.	Test to see if there is power to the motor with the ignition in "Start" position. Refer to the Electrical Section.
1.8	None of the above.	Refer to a qualified service technician for further troubleshooting.

2.0 Turns over but will not start. there is no spark. (To check for spark, refer to engine manual.)

	Possible Cause	Solution
2.1	The recovery tank is full.	Drain the tank.
2.2	The recovery tank float is faulty.	Inspect the float. Repair or replace as necessary.
2.3	The engine ignition system in faulty.	Refer to a qualified service technician for further troubleshooting.



3.0 Turns over but will not start; there is spark. (To check for spark, refer to engine manual.)

	Possible Cause	Solution
3.1	Fuel is not reaching the carburetor.	Test for power to the fuel pump. Refer to Electrical Section.
		If power is present, inspect the fuel pump. Replace if necessary.
		Inspect the fuel lines between the source and the carburetor. Repair or replace as necessary.
3.2	The carburetor solenoid is faulty.	Test for power to the solenoid. Refer to Electrical Section.
		If power is present, inspect the solenoid. Replace if necessary.
3.3	The engine is flooded.	Pull the throttle cable completely and crank until the engine starts.
3.4	The spark plugs are worn or dirty.	Inspect and replace as necessary.
3.5	None of the above.	Refer to a qualified service technician for further troubleshooting.

4.0 Will not come up to normal operating rpm (Engine should be adjusted to run at 3,150 rpm under a vacuum load of 0" Hg.)

	Possible Cause	Solution
4.1	The throttle linkage is out of adjustment.	Inspect for broken or loose linkage. Repair or replace as necessary.
4.2	Excessive load on the engine.	Inspect and clean the recovery tank filters.
		Inspect the recovery tank to the blower hose. Repair or replace as necessary.
4.3	Excessive back pressure on the engine exhaust.	Inspect for blockage in the heat exchanger. Clean or replace as necessary.

5.0 Runs rough at high speed

	Possible Cause	Solution
5.1	The spark plug(s) are faulty.	Remove and inspect the plugs. Clean or replace as necessary.
5.2	The spark plug wire(s) are faulty.	Inspect the wires and connectors for damage or loose connections. Repair or replace as necessary.
5.3	Inadequate fuel supply to the carburetor.	Check if the fuel pump is mounted in a vertical position near the fuel source. Correct if necessary.
		Check for blockage in the filter. Repair or replace as necessary.
		If operating altitudes have changed, contact your distributor to have the engine carburetor jets checked.

6.0 Runs rich.(Black smoke)

	Possible Cause	Solution
6.1	The air filter is dirty.	Inspect and replace as necessary.
6.2	The choke is partially closed.	Inspect and adjust or repair as necessary.
6.3	Excessive fuel to the carburetor.	Check to see if the proper fuel pump is installed.
		If operating altitudes have changed, contact your distributor to have the engine carburetor jets checked.



7.0 Engine overheats

	Possible Cause	Solution
7.1	Poor ventilation in the van.	Open all the van doors.
		Install a roof vent in the van.
		Remove any dividers or other objects impeding airflow around the truckmount.
7.2	Low oil level.	Check the level and fill as necessary. CAUTION Running the engine with a low oil level can cause severe damage to the engine. If this situation occurs, the engine should be inspected by a qualified service technician.
7.3	The engine rpm is too high.	Check the engine rpm. Adjust as necessary to run at 3,150 rpm under a vacuum load of 0" Hg.
7.4	Excessive back pressure on the engine exhaust.	Inspect for blockage in the heat exchanger. Clean or replace as necessary.

TILE SYSTEM

1.0 The pump will not come up to normal cleaning pressure

	Possible Cause	Solution
1.1	The tile pressure adjusting valve is faulty.	Inspect the valve. Repair or replace if necessary.
1.2	Worn seals or valves in the tile pump.	Test the pump output volume directly from the pump at normal running rpm. If the volume is below the manufacturer's specifications, replace the seals and inspect for defective valves.
1.3	The pump rpm is too low.	Check for a loose pump belt. Adjust or replace as necessary.
		Check the engine rpm and adjust as necessary to 3,150 rpm under a 0" Hg vacuum load.
1.4	The tile primary orifice is missing or loose.	Remove and inspect. Tighten or replace as necessary.
1.5	The tile primary and secondary orifices have been installed incorrectly.	Inspect and reverse if necessary. Refer to the Machine Assemblies & Parts List Section.
1.6	The tile primary orifice is worn.	Measure the orifice size and replace as necessary. Correct size is 0.039".

2.0 No pressure reading on gauge

	Possible Cause	Solution
2.1	The pump belt is broken.	Inspect and replace if necessary.
2.2	The gauge is faulty.	Replace the gauge.
2.3	Water box is empty.	Fill the water box.
2.4	Water box switch is faulty.	Replace water box switch.



3.0 The psi gauge reads normal: low pressure from wand

	Possible Cause	Solution
3.1	Restriction in the cleaning tool.	Inspect the tool jet(s) and clean or replace as necessary.
		Inspect any filters in the cleaning tool and clean or replace as necessary.
3.2	Faulty quick connect in the system.	Inspect each quick connect and replace as necessary.
3.3	Restriction in one of the solution hoses.	Remove the quick connects and inspect hoses. Clean or replace as necessary.
3.4	Hard water deposits restricting the system.	Descale the truckmount.

4.0 Pressure pulsation

	Possible Cause	Solution
4.1	Air leak between the water box and pump.	Check all the hoses and fittings for cuts, breaks, cracks, etc. Repair as necessary.
4.2	The check valve(s) in the pump are faulty.	Remove each valve and inspect for correct operation. See the Machine Maintenance Section.

5.0 Water box empty or fills slowly

	Possible Cause	Solution
5.1	Restriction in the water supply system.	Inspect the supply system from the source through the incoming quick connect.
5.2	The float valve in the water box is faulty.	Disassemble and inspect the valve. Repair or replace as necessary.

6.0 The water box overflows

	Possible Cause	Solution
6.1	The float valve in the water box is faulty.	Disassemble and inspect the valve. Repair or replace as necessary.
6.2	The float has absorbed water and lost buoyancy.	Detach the float and check to see if it will float to the surface. Replace the valve as necessary.
6.3	The float has come out of adjustment.	Adjust the float as necessary.



CARPET/UPHOLSTERY SYSTEM

1.0 Unit does not spray solution in carpet/uphostry mode

	Possible Cause	Solution
1.1	Solution tank(s) are empty.	Fill as necessary.
1.2	Hose is not fully connected.	Make sure hose quick connects are all fully engaged and attached to machine.
1.3	Solution hose valve is shut-off	Check hoses from the dash to the carpet/uphostry tool valves are open (if equiped).
1.4	Orifice is cloged.	If solidified chemical is found in orifice drain natural tank and pour 3 gallons of vinegar into it. Run pump without orifice until you get vinegar out the natural QC. Shut pump off let sit 60+ minutes . Run pump until all vinegar is flushed out of tank, then add water to tank and flush any additional debris or chemical solution out of system. Clean orifice and screen and install. "
1.5	Air is trapped in pump.	Remove the pump outlet hose and run pump until solution comes out.
1.6	Lines are restricted from pump	Verify hose is not crimped, pinched, or otherwise restriced.
1.7	Pump inlet is restricted	Open solution tank to check for debis is not blocking pump inlet.
1.8	Pump is not working - electrical	Check wiring to pump; pump should have 12 volts with switch on.
1.9	Pump is not working - mechanical	1) Remove hose from pump outlet - verify pump is running. 2) Remove hose from pump inlet - check for obstructions. 3) Check pressure switch is working and not shutting off the pump. 4) Check pressure switch is not set too low."

VACUUM SYSTEM

1.0 A weak vacuum at wand. The gauge reads normal.

	Possible Cause	Solution
1.1	Blockage in the hoses or wand tube	Disconnect the hoses and check for an obstruction.
1.2	Excessive length of hose connected to the truckmount	Do not attach excessive lengths of hose.

2.0 A weak vacuum

	Possible Cause	Solution
2.1	Air leak somewhere in the vacuum system.	Check the vacuum relief valve for proper adjustment.
		Carefully check all the vacuum hoses for a cut or break.
		Check the recovery tank lid gasket.
		Make sure the recovery tank drain valve is fully closed.
2.2	The vacuum blower is turning too slowly.	Check the rpm of the engine. Adjust as necessary to 3,150 rpm under a 0" Hg vacuum load.
2.3	The vacuum gauge is defective.	Test the gauge and replace if necessary.

3.0 The vacuum gauge reads too high with no hoses attached

	Possible Cause	Solution
3.1	The filter in recovery tank is clogged.	Remove and clean or replace as necessary.
3.2	The hose from recovery tank to the vacuum blower is collapsed internally.	Inspect and replace as necessary.

4.0 Excessive noise produced by the blower

	Possible Cause	Solution
4.1	The blower is low on oil.	Inspect the oil levels and replenish as necessary. Note: Running the blower with low oil levels can cause severe damage. If this situation occurs the blower should be inspected by a qualified service technician.
4.2	The vacuum blower has internal damage.	Refer to a qualified service technician.



5.0 The vacuum blower is locked and will not turn

	Possible Cause	Solution
5.1	Truckmount has been inactive for a period of time and the blower was not properly lubricated prior to final shutdown. Rust has possibly built up on the internal surfaces.	Spray penetrating oil into the blower and let sit for at least 1 hour. Then very carefully use pipe wrench on the outer diameter of the pulley on the coupler to attempt to free lobes of the blower. Do not use a wrench directly on the blower shaft.
		If unable to free up the blower in this manner, refer to a qualified service technician.
5.2	There is internal damage to the blower.	Refer to a qualified service technician.

6.0 Water in truckmount exhaust

	Possible Cause	Solution
6.1	The recovery tank has been filled with foam or overfilled with water.	Inspect the recovery tank. If full, drain the tank.
		Inspect the high level shutoff switch for proper operation. Clean or replace the switch as necessary.
		If foam is in recovery tank, use de-foamer on the carpet being cleaned.
6.2	Condensation in system.	This will be more common in cool weather and humid climates. If this is the cause, it should dissipate after a few minutes of running.
6.3	The heat exchanger is leaking water.	Inspect and repair or replace as necessary.

8 - Assemblies and Parts List

This section of the manual provides detailed illustrations and parts lists for the following assemblies.

NOTICE

When ordering parts for assemblies, first refer to the appropriate assembly listed here and then find the part number listed on that specific page. In most cases, you do not have to order the entire assembly to get a part.

If you have an electronic copy (a .pdf) of this manual, you can search for the part number by pressing the **CTRL** key and the **F** key at the same time. This will “pop up” the Find window on your monitor. Type the part number, including dashes, into the Find window and press the **Enter** key.

■ Machine Assembly with 35 Gallon Tank and 15 Gallon Tank Parts List.....	8-4	■ Silencer Assembly Parts List.....	8-40
■ Machine Assembly with 50 Gallon Tank Parts List.....	8-6	■ Top Cover - CTS 403 Flex Assembly Parts List.....	8-41
■ Console Assembly Parts List.....	8-13	■ Water Box Assembly Parts List.....	8-43
■ Blower Assembly Parts List.....	8-15	■ 70 Gallon Universal Recovery Tank (URT) Assembly Parts List.....	8-46
■ Dash Assembly Parts List.....	8-18	■ Cover, 70 Gal URT, Single Vac Assembly Parts List.....	8-47
■ Engine Assembly Parts List.....	8-21	■ Vacuum Relief Valve, URT Assembly.....	8-48
■ Exhaust Assembly Parts List.....	8-22	■ Dump Hose Hook Up Kit.....	8-49
■ Diverter Valve Actuator Assembly Parts List.....	8-23	■ Sacrificial Anode Assembly.....	8-50
■ Exhaust Diverted Assembly Parts List.....	8-25	■ 35 Gallon and 15 Gallon Tank Flex Kit Assembly Parts List.....	8-51
■ Exhaust Diverter Valve Assembly Parts List.....	8-26	■ 35 Gallon Tank Flex Chemical Caddy Assembly Parts List.....	8-52
■ Exhaust Manifold Assembly Parts List.....	8-27	■ 35 Gallon and 15 Gallon Tank Flex Assembly Parts List.....	8-54
■ Frame Assembly Parts List.....	8-30	■ 50 Gallon Tank Flex Kit Assembly Parts List.....	8-55
■ Idler Pulley Assembly Parts List.....	8-31	■ 50 Gallon Tank Flex Chemical Caddy Assembly Parts List.....	8-56
■ Solenoid Valve Assembly Parts List.....	8-32	■ 50 Gallon Tank Flex Assembly Parts List.....	8-57
■ Back Pressure Switch Mount Assembly Parts List.....	8-33	■ Pump Cover Assembly.....	8-58
■ Heat Exchanger Assembly Parts List.....	8-35	■ Pump - Passenger Flex Kit.....	8-59
■ Orifice Assembly Parts List.....	8-36	■ Flex Pump Assembly.....	8-60
■ Pump Assembly Parts List.....	8-38	■ Flex Pump Replacement Parts Kits.....	8-61
■ By-Pass Valve Assembly Parts List.....	8-39		

Some of the illustrations in this section reference sealants, thread lockers, adhesive, primer, anti-seize and lubricant specifications that are used in the construction of HydraMaster equipment.

Refer to Figure 8-1 to identify those substances such as A1, A2 and so forth. Equivalent products are acceptable if they meet or exceed current specifications and are approved by HydraMaster.





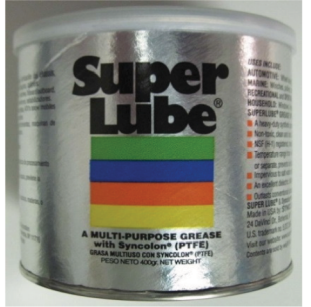
Adhesive Material Production Line Reference Card from ENG-45975 Rev. 0					
<p>A1 Silicone RTV</p> 	<p>A2 Loctite 567</p> 	<p>A3 Loctite 545</p> 	<p>A4 Teflon Tape</p> 	<p>E1 Loctite 51252 Grease</p> 	
<p>B1 Loctite 242</p> 	<p>B2 Loctite 262</p> 	<p>B3 Loctite 266</p> 	<p>C1 Gapper</p> 	<p>D1 Loctite 7649</p> 	<p>E2 Molykote Anti-Seize</p> 
<p>B4 Loctite 222MS</p> 	<p>B5 Loctite 425</p> 	<p>E4 Super Lube</p> 	<p>E5 SKF Anti-Fret</p> 		

Figure 8-1. Adhesive/Sealant Material Reference

Figure 8-2. Machine Assembly with 35 Gallon Tank and 15 Gallon Tank - View 1 of 2
750-010-758-10 Rev. C

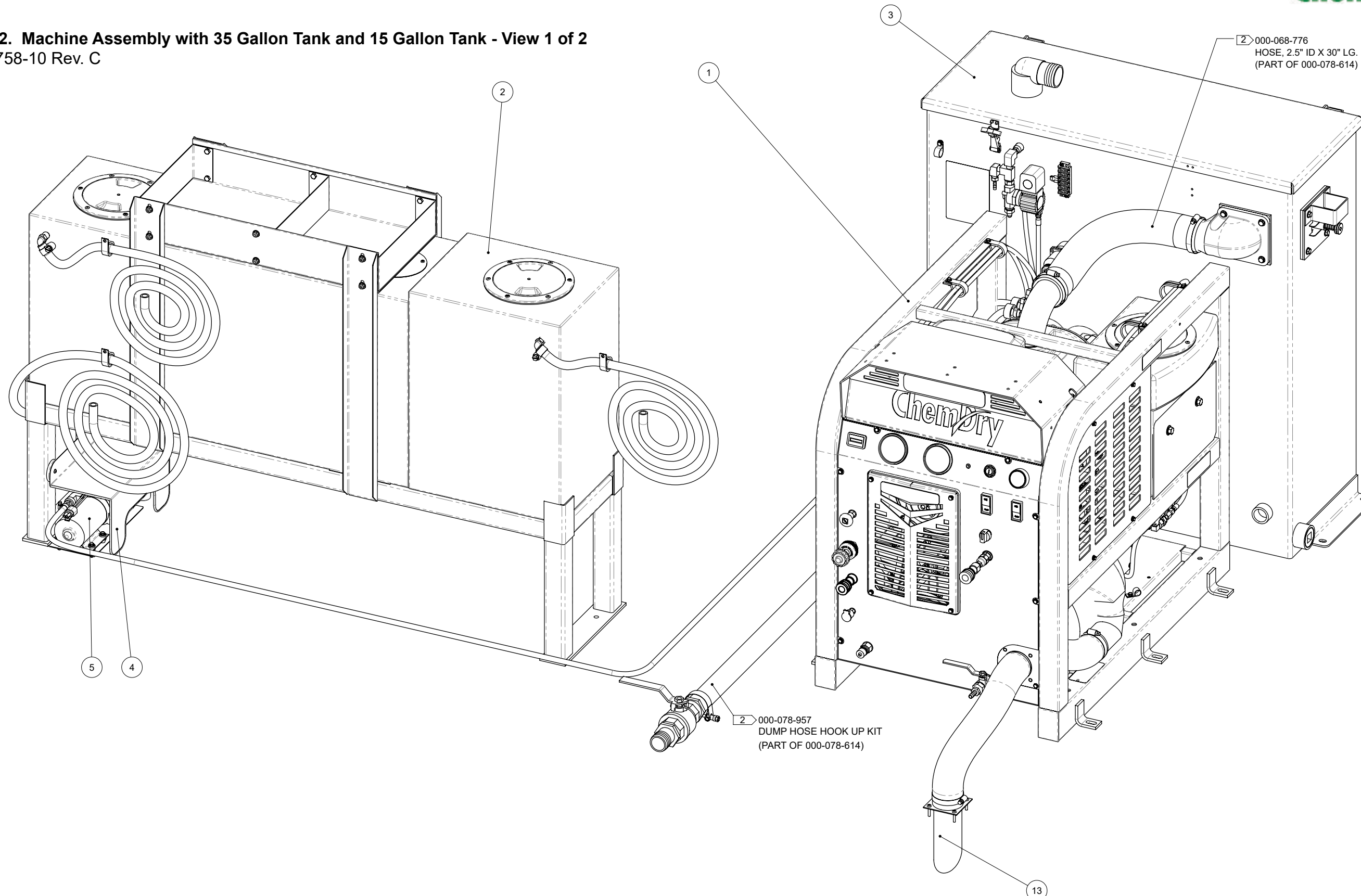




Figure 8-3. Machine Assembly with 35 Gallon Tank and 15 Gallon Tank - View 2 of 2
750-010-758-10 Rev. C

Machine Assembly with 35 Gallon Tank and 15 Gallon Tank Parts List

Item	Part Number	Description	Qty
1	610-050-749	ASSEMBLY, CONSOLE - CTS 403 FLEX	1
2	000-163-751	ASSEMBLY, TANK - 35/15 GAL - HRI FLEX KIT	1
3	610-003-749	ASSEMBLY, 70 GALLON URT - CTS 403	1
4	000-041-707	ASSEMBLY, COVER - PUMP - HRI FLEX	1
5	601-021-752	ASSEMBLY, PUMP - PASSENGER - HRI FLEX KIT	1
6	000-063-078	HARNESS, WIRE - CTS 403 FLEX	1
7	000-068-598	HOSE, 1-1/2" DUMP - BLUE	1
8	000-068-317	HOSE, 1-1/2" X 10' WHIP BLUE	1
9	000-068-990	HOSE, 1/4" X 125' SOLUTION	1
10	000-068-065	HOSE, 2" X 50' VACUUM BLUE	1
11	000-078-934	KIT, INSTALLATION VER 3 - HRI FLEX	1
12	000-078-614	KIT, PARTS PACKAGE CTS 403	1
13	000-078-515	KIT, THRU FLOOR EXHAUST 2.5"	1

NOTICE

Items 6 - 12 not shown on illustration.

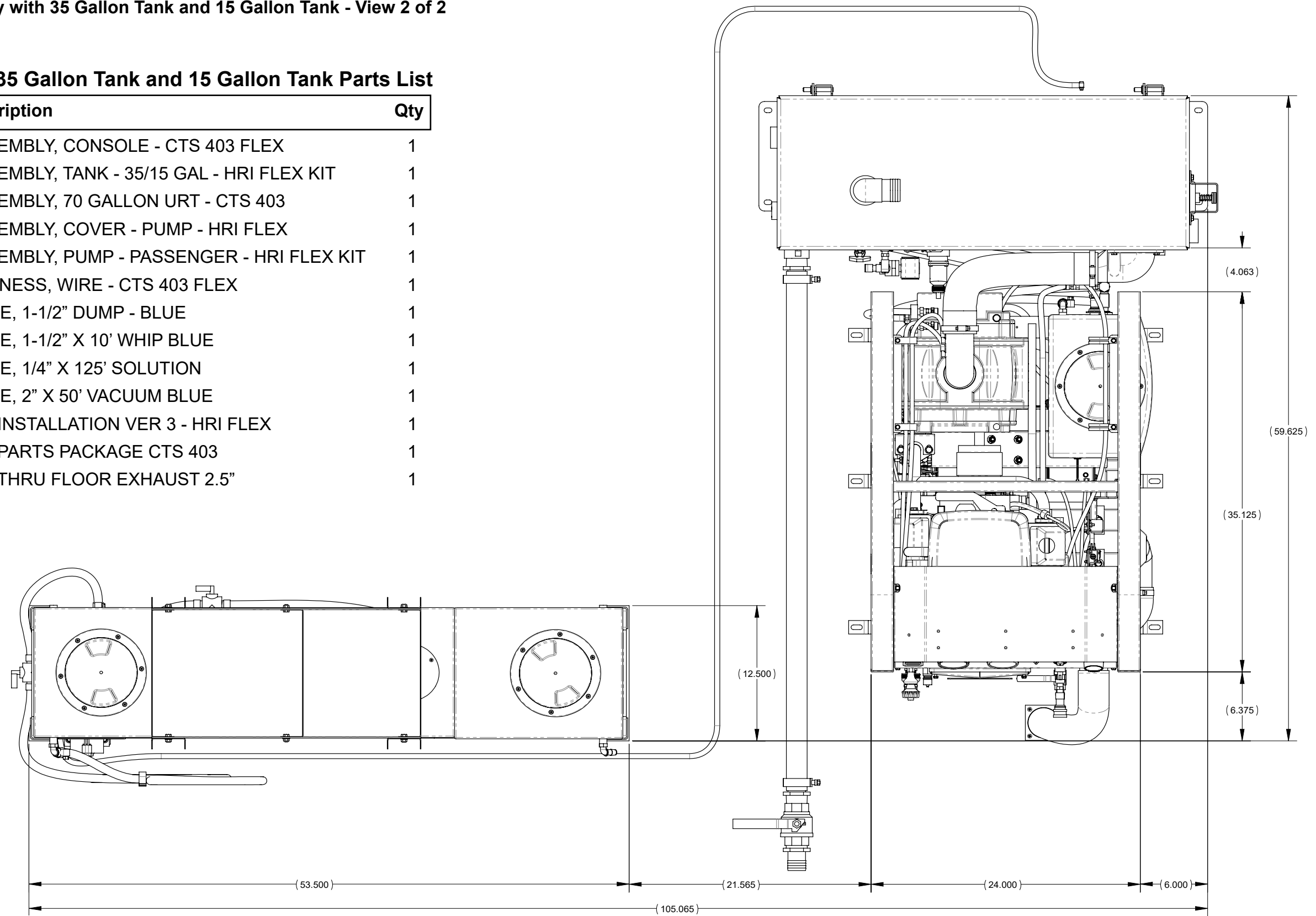


Figure 8-4. Machine Assembly with 50 Gallon Tank - View 1 of 2
750-010-749-10 Rev. B

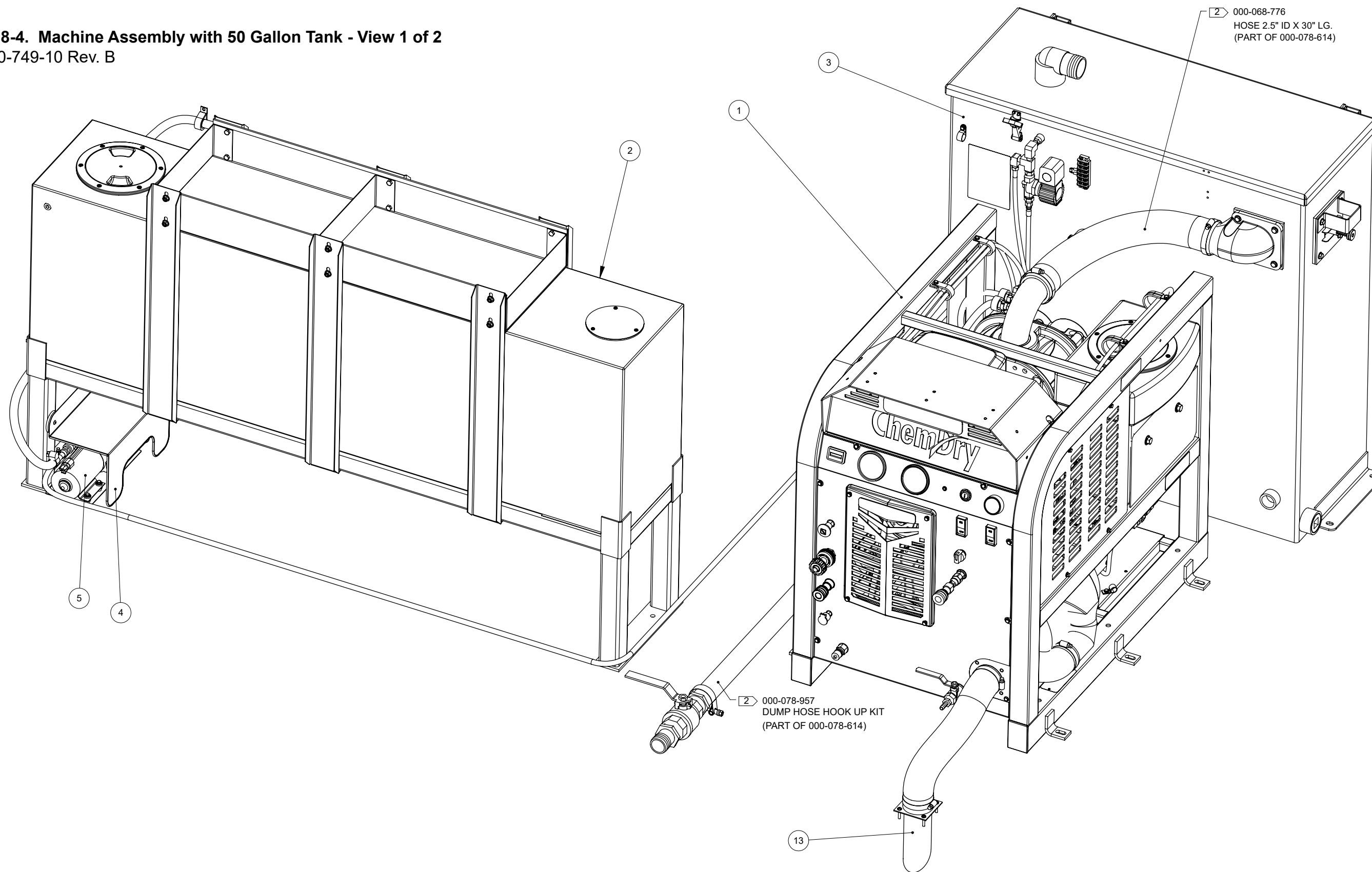




Figure 8-5. Machine Assembly with 50 Gallon Tank - View 2 of 2
750-010-749-10 Rev. B

Machine Assembly with 50 Gallon Tank Parts List

Item	Part Number	Description	Qty
1	610-050-749	ASSEMBLY, CONSOLE - CTS 403 FLEX	1
2	000-163-751	ASSEMBLY, TANK - 50 GAL - HRI FLEX KIT	1
3	610-003-749	ASSEMBLY, 70 GALLON URT - CTS 403	1
4	000-041-707	ASSEMBLY, COVER - PUMP - HRI FLEX	1
5	601-021-752	ASSEMBLY, PUMP - PASSENGER - HRI FLEX KIT	1
6	000-063-078	HARNESS, WIRE - CTS 403 FLEX	1
7	000-068-598	HOSE, 1-1/2" DUMP - BLUE	1
8	000-068-317	HOSE, 1-1/2" X 10' WHIP BLUE	1
9	000-068-990	HOSE, 1/4" X 125' SOLUTION	1
10	000-068-065	HOSE, 2" X 50' VACUUM BLUE	1
11	000-078-934	KIT, INSTALLATION VER 3 - HRI FLEX	1
12	000-078-614	KIT, PARTS PACKAGE CTS 403	1
13	000-078-515	KIT, THRU FLOOR EXHAUST 2.5"	1

NOTICE

Items 6 - 12 not shown on illustration.

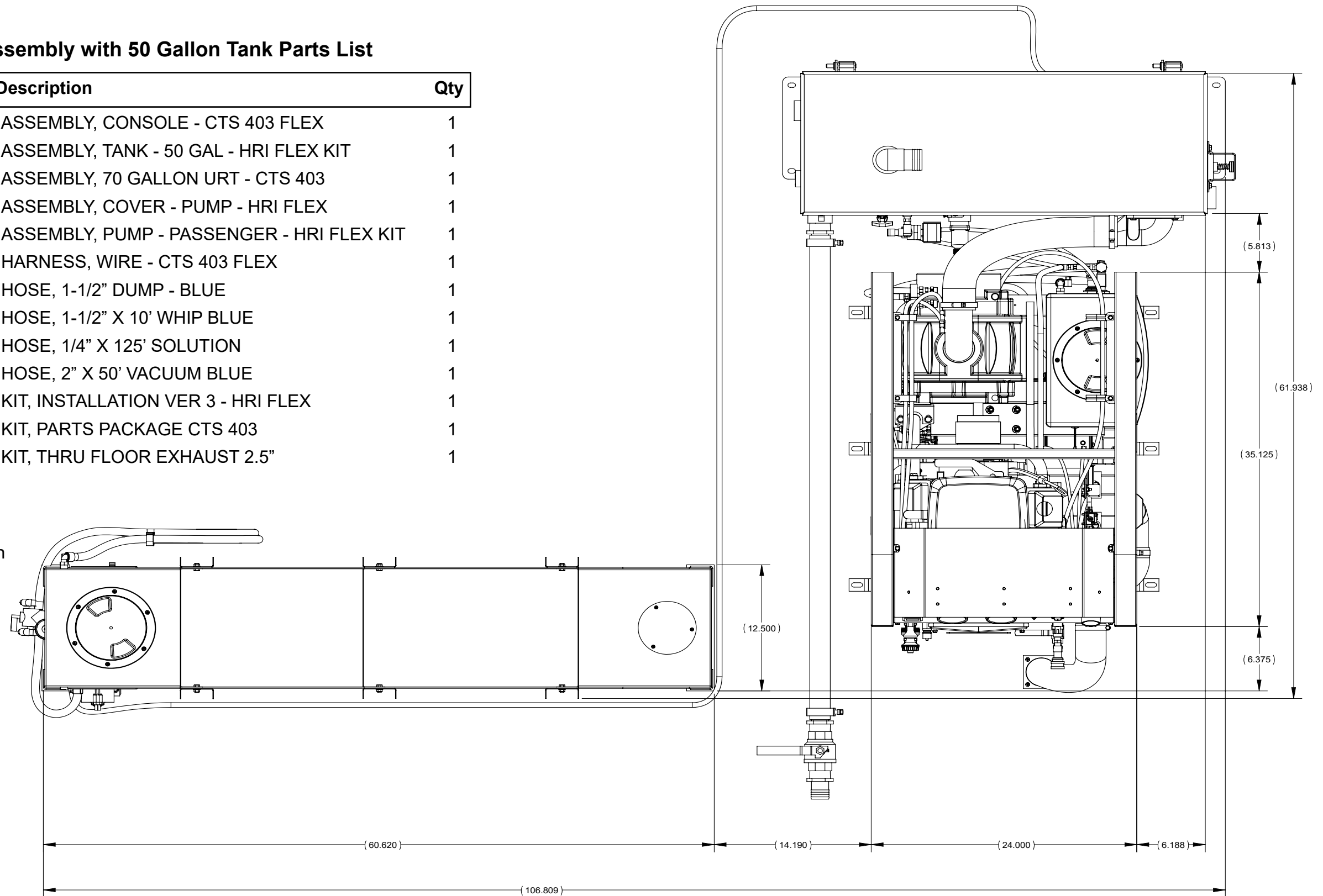


Figure 8-6. Console Assembly - View 1 of 6
610-050-749 Rev. C

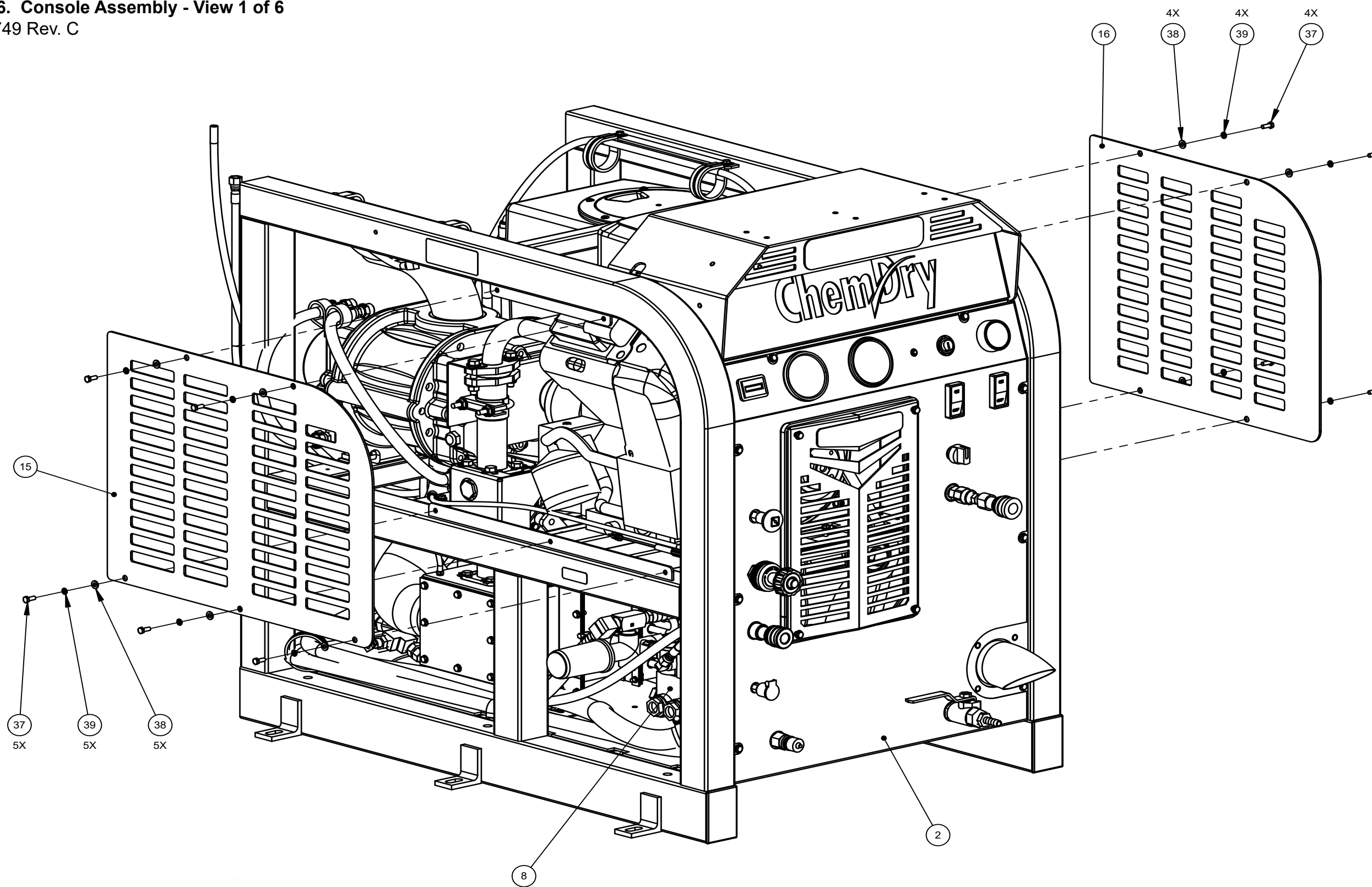


Figure 8-7. Console Assembly - View 2 of 6
610-050-749 Rev. C

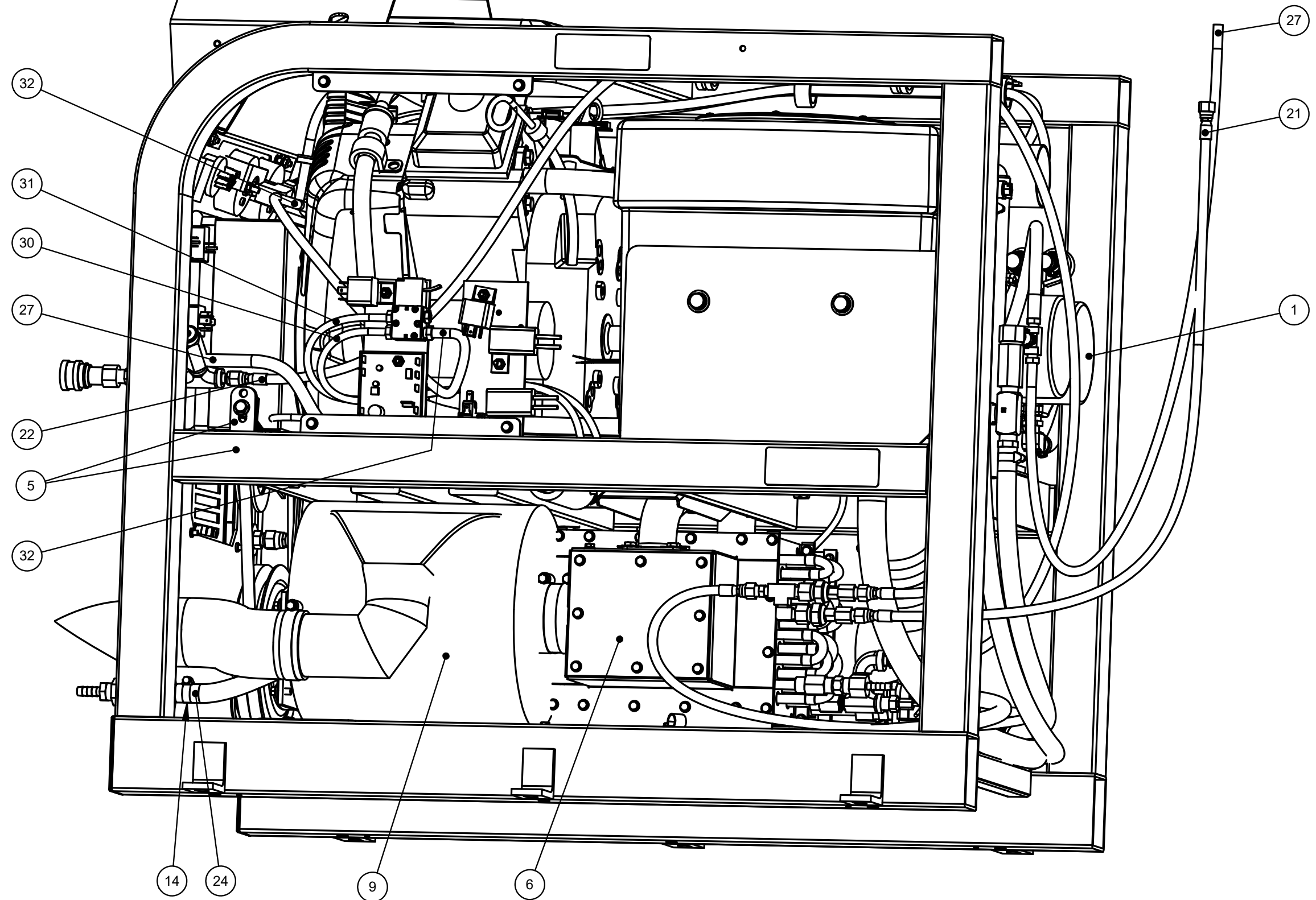


Figure 8-8. Console Assembly - View 3 of 6
610-050-749 Rev. C

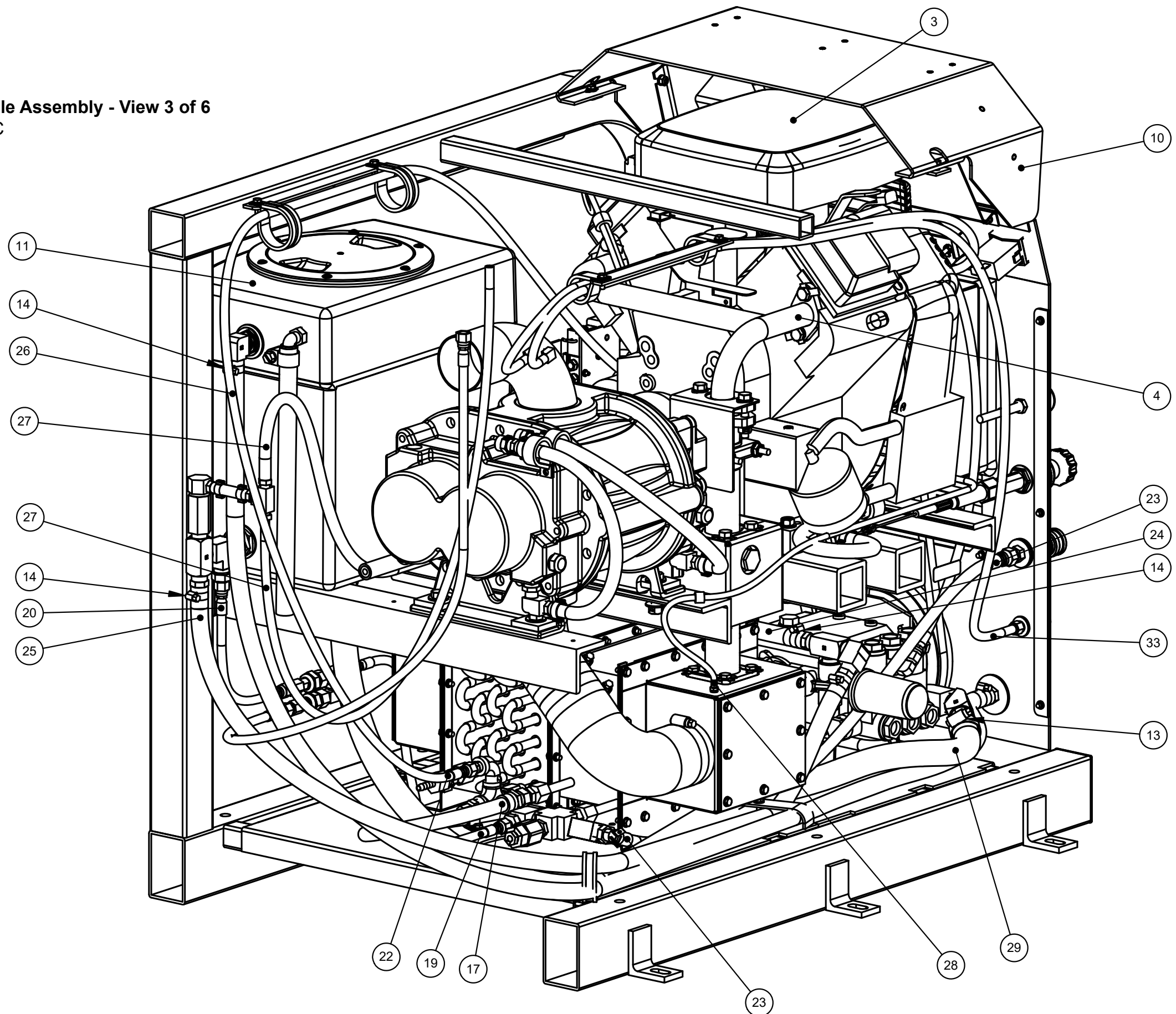


Figure 8-9. Console Assembly - View 4 of 6
610-050-749 Rev. C

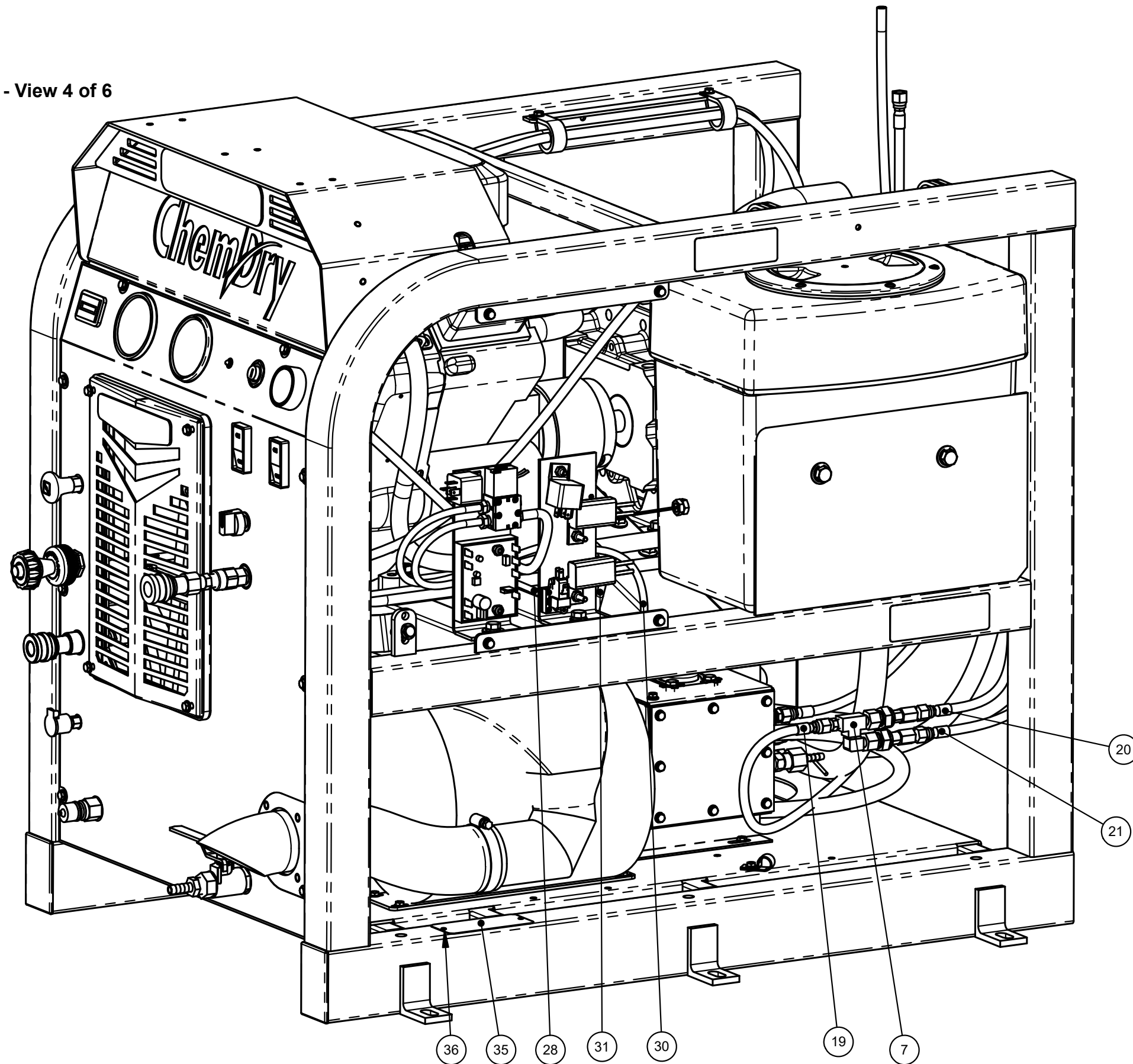


Figure 8-10. Console Assembly - View 5 of 6
610-050-749 Rev. C

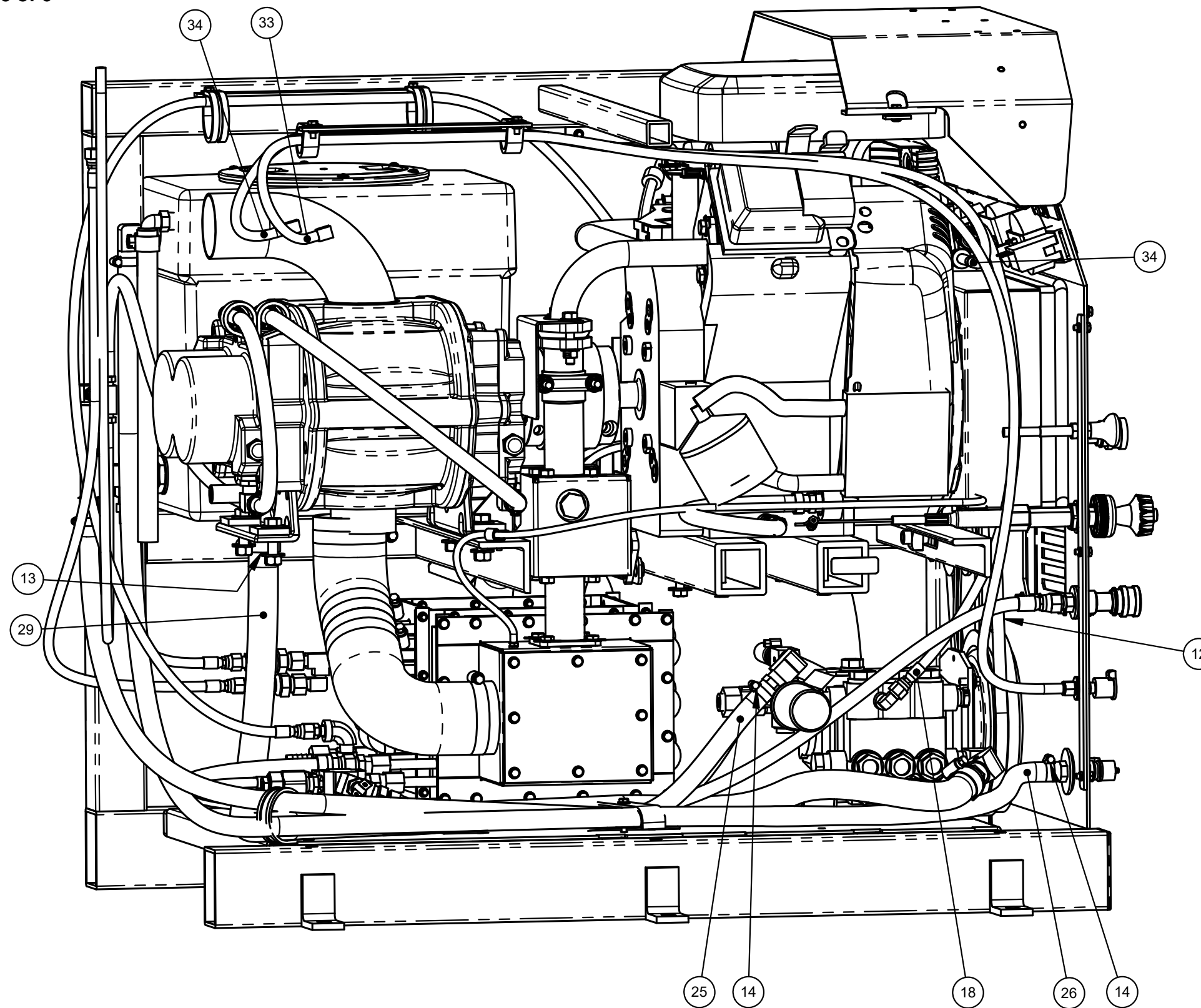
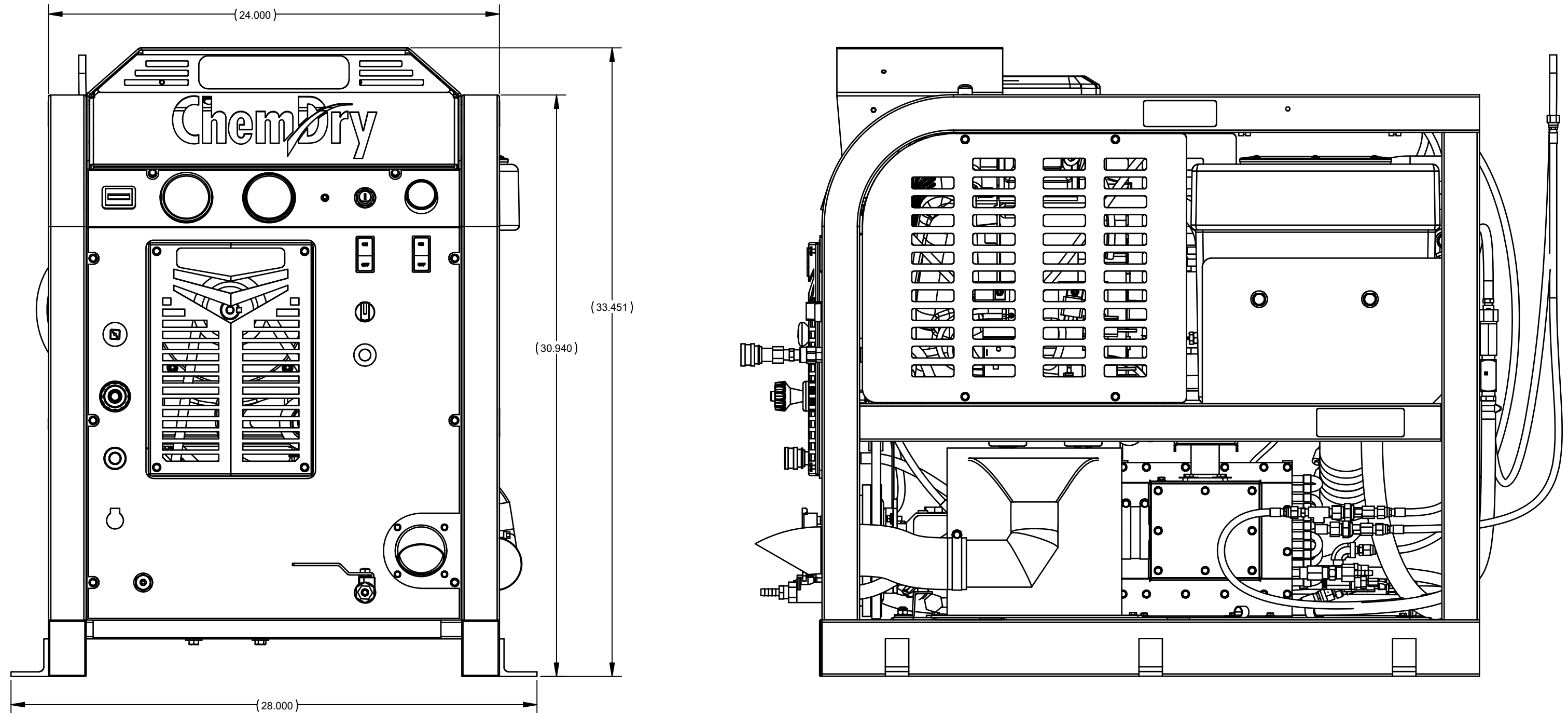


Figure 8-11. Console Assembly - View 6 of 6
610-050-749 Rev. C



Console Assembly Parts List

Item	Part Number	Description	Qty
1	610-002-747	ASSEMBLY, BLOWER - CTS 403 FLEX	1
2	610-018-749	ASSEMBLY, DASH - CTS 403 FLEX	1
3	610-004-749	ASSEMBLY, ENGINE - CTS 403 FLEX	1
4	610-013-749	ASSEMBLY, EXHAUST - CTS 403	1
5	610-001-749	ASSEMBLY, FRAME - CTS 403 FLEX	1
6	610-005-749	ASSEMBLY, HEAT EXCHANGER - CTS 403 FLEX	1
7	610-021-729	ASSEMBLY, ORIFICE	1
8	610-007-747	ASSEMBLY, PUMP - CTS 403 FLEX	1
9	610-021-728	ASSEMBLY, SILENCER	1
10	610-022-749	ASSEMBLY, TOP COVER - CTS 403 FLEX	1
11	610-010-749	ASSEMBLY, WATER BOX - CTS 403 FLEX	1
12	000-010-124	BELT, 9430HD	1
13	000-033-029	CLAMP, SIZE #12 HOSE	2
14	000-033-005	CLAMP, SIZE #5 HOSE	6
15	000-041-451	COVER, LEFT SIDE - COATED	1
16	000-041-452	COVER, RIGHT SIDE - COATED	1
17	000-068-588	HOSE ASSEMBLY, THROB 52" LG.	1
18	000-068-518	HOSE ASSEMBLY, 3/16" TEFLON X 18.25" LG. (PUMP TO GAUGE)	1
19	000-068-888	HOSE ASSEMBLY, 3/16" TEFLON X 24" LG. (HX TO ORIFICE ASSY)	1
20	000-068-203	HOSE ASSEMBLY, 3/16" TEFLON X 34" LG. (ORIFICE ASSY TO WB)	1
21	000-068-627	HOSE ASSEMBLY, 3/16" TEFLON X 44" LG. (ORIFICE TO REC TANK)	1
22	000-068-760	"HOSE ASSEMBLY, 3/16" TEFLON X 71" LG. (HX TO CHEMDRY SOL OUT)"	1

Item	Part Number	Description	Qty
23	000-068-724	HOSE ASSEMBLY, 5/16" TEFLON X 18" LG. (HX TO SOL OUT)	1
24	000-068-967	HOSE, 1/2" I.D. RUBBER x 20" LG. (WB DRAIN)	1
25	000-068-968	HOSE, 1/2" I.D. RUBBER x 56" LG. (PUMP TO WB)	1
26	000-068-969	HOSE, 1/2" I.D. RUBBER x 69" LG. (FRESH WATER IN TO WB)	1
27	000-068-997	"HOSE, 1/4" I.D. RUBBER X 60" LG. (POP OFF VALVE TO THERMO VALVE TEE) & (THERMO VALVE TEE TO REC TANK)"	1
28	000-068-1133	HOSE, 1/8" HI-TEMP SILICONE X 40" LG. BLACK VAC	1
29	000-068-1059	HOSE, 3/4" I.D. RUBBER x 56" LG. (PUMP TO WB)	1
30	000-068-348	HOSE, 5/32" I.D. VACUUM X 14" LG. (SOL VAVLE TO AIR CYLINDER)	1
31	000-068-1009	HOSE, 5/32" I.D. VACUUM X 16" LG. (SOL VAVLE TO AIR CYLINDER)	1
32	000-068-347	HOSE, 5/32" I.D. VACUUM X 36" LG. (SOL INLET TO ENGINE TEE)	1
33	000-068-978	HOSE, 5/32" I.D. VACUUM X 52" LG. (BLOWER TO LUBE PORT)	1
34	000-068-977	HOSE, 5/32" I.D. VACUUM X 82" LG. (BLOWER TO VAC GAUGE)	1
35	000-105-012	PLATE, MACHINE SERIAL I.D.	1
36	000-140-001	RIVET, AB4-3A ALUMINUM POP 1/8" x 1/4" LG. (GRIP RANGE 0.126"-0.187")	2
37	000-143-126	SCREW, #10-24UNC x 0.50" LG. HEX HEAD	9
38	000-174-001	WASHER, #10 FLAT	9
39	000-174-014	WASHER, #10 LOCK	9

Figure 8-12. Blower Assembly - View 1 of 2
610-002-747 Rev. B

NOTICE

See Figure 8-1 for adhesive/sealant information.

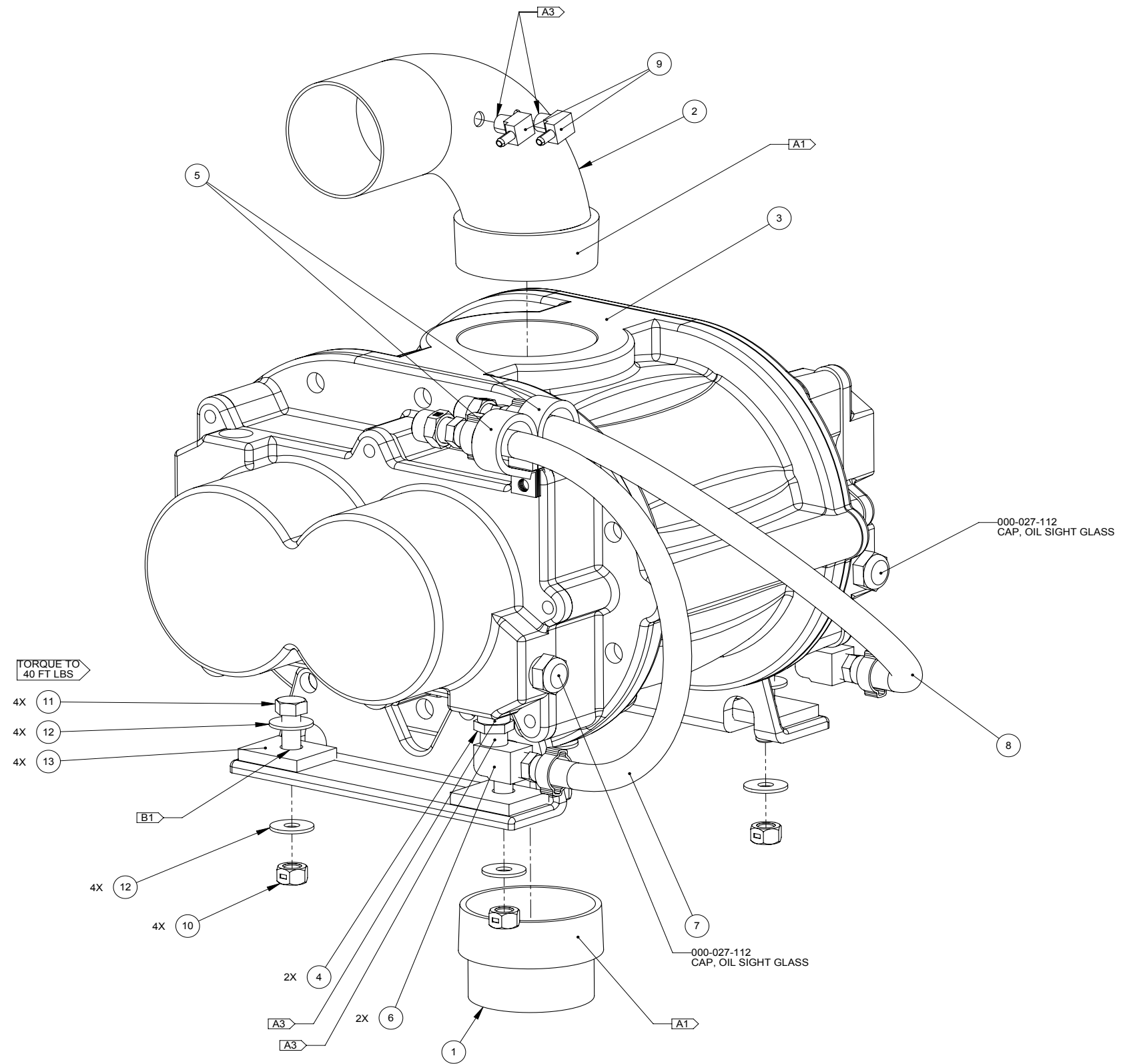
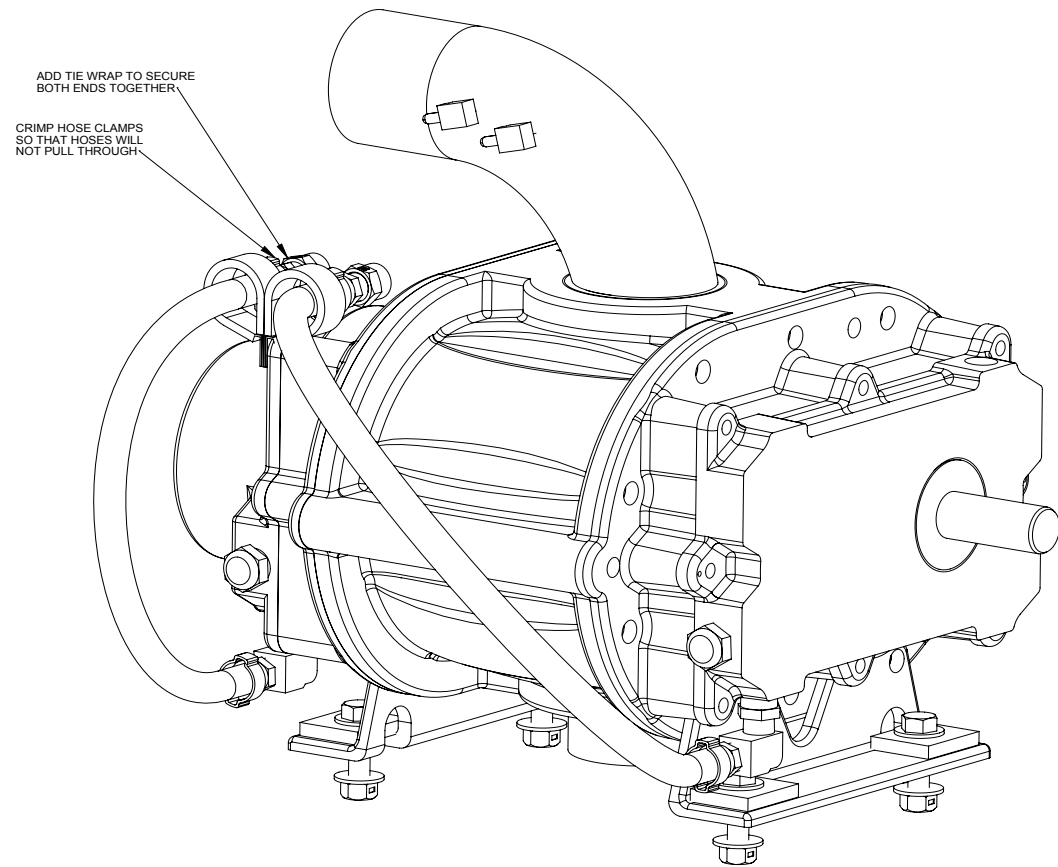
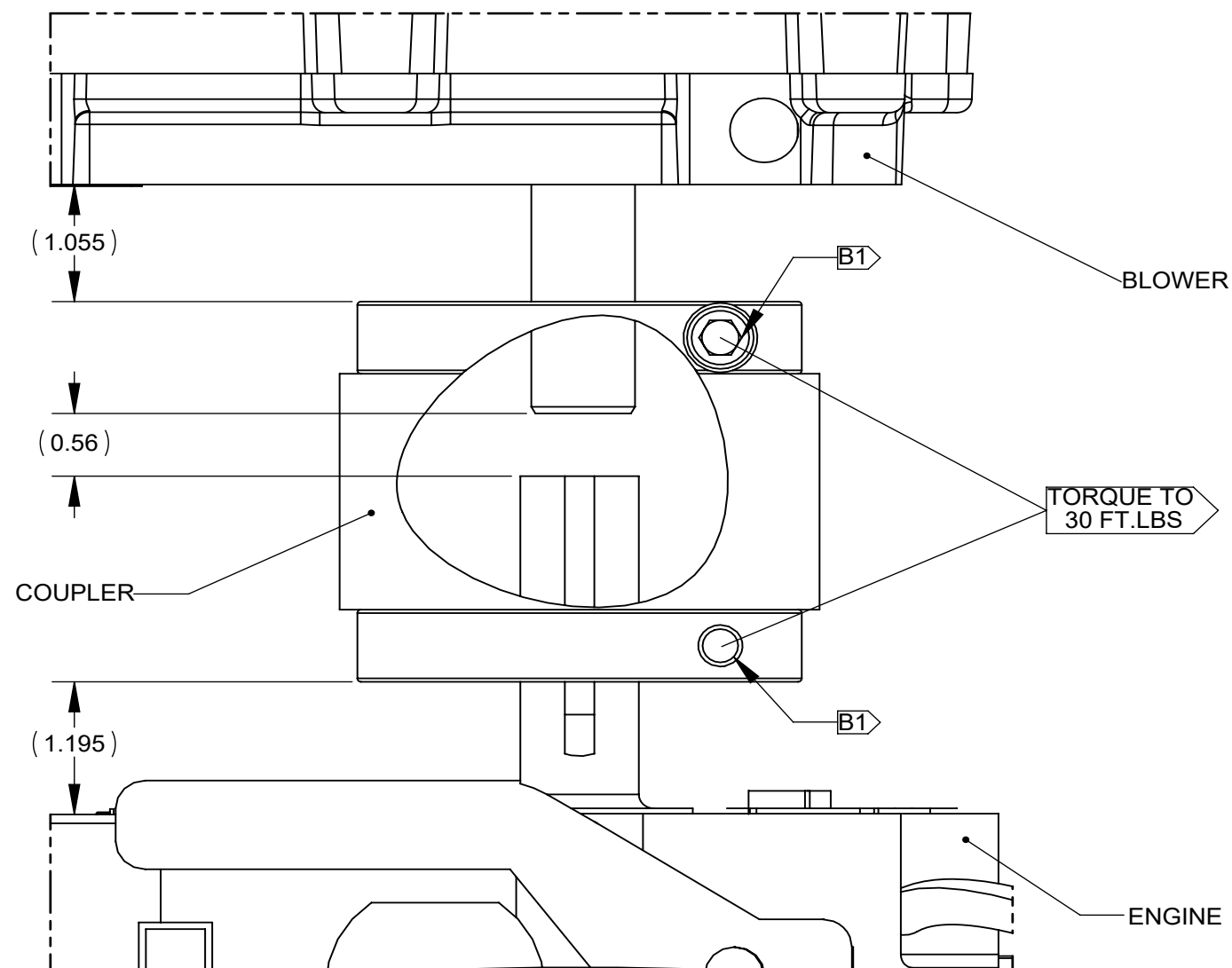


Figure 8-13. Blower Assembly - View 2 of 2
610-002-747 Rev. B



Blower Assembly Parts List

Item	Part Number	Description	Qty
1	000-001-140	Adapter, 2 1/2" Npt To 2 1/2" Od Tube - Coated	1
2	000-001-141	Adapter, 2.5" Mnpt X 2.5" Od Elbow - Coated	1
3	000-111-135	Blower, 3006 Competitor Trilobe	1
4	000-052-061	Bushing, 3/8" Npt X 1/4" Fpt	2
5	000-033-057	Clamp, 1" Cushion Loop	2
6	000-052-085	Elbow, 1/4" Npt Street	2
7	000-068-794	Hose Assembly, 3/8" I.d. Hi Temp Rubber X 17" Lg. Drain	1
8	000-068-794	Hose Assembly, 3/8" I.d. Hi Temp Rubber X 17" Lg. Drain	1
9	000-052-106	Insert, 1/8" Npt X 5/32" Barb X 90°	2
10	000-094-015	Nut, 3/8"-16Unc Hex 2 Way Locking	4
11	000-143-200	Screw, 3/8"-16Unc X 1.50" Lg. Hex Head Grade 8	4
12	000-174-004	Washer, 5/16" Flat, Uss	8
13	000-174-068	Washer, Blower Feet - Coated	4

NOTICE

See Figure 8-1 for adhesive/sealant information.

Figure 8-14. Dash Assembly - View 1 of 2
610-018-749 Rev. B

NOTICE

All labels part of label set P/N 000-081-555.
Individual labels not available for purchase.

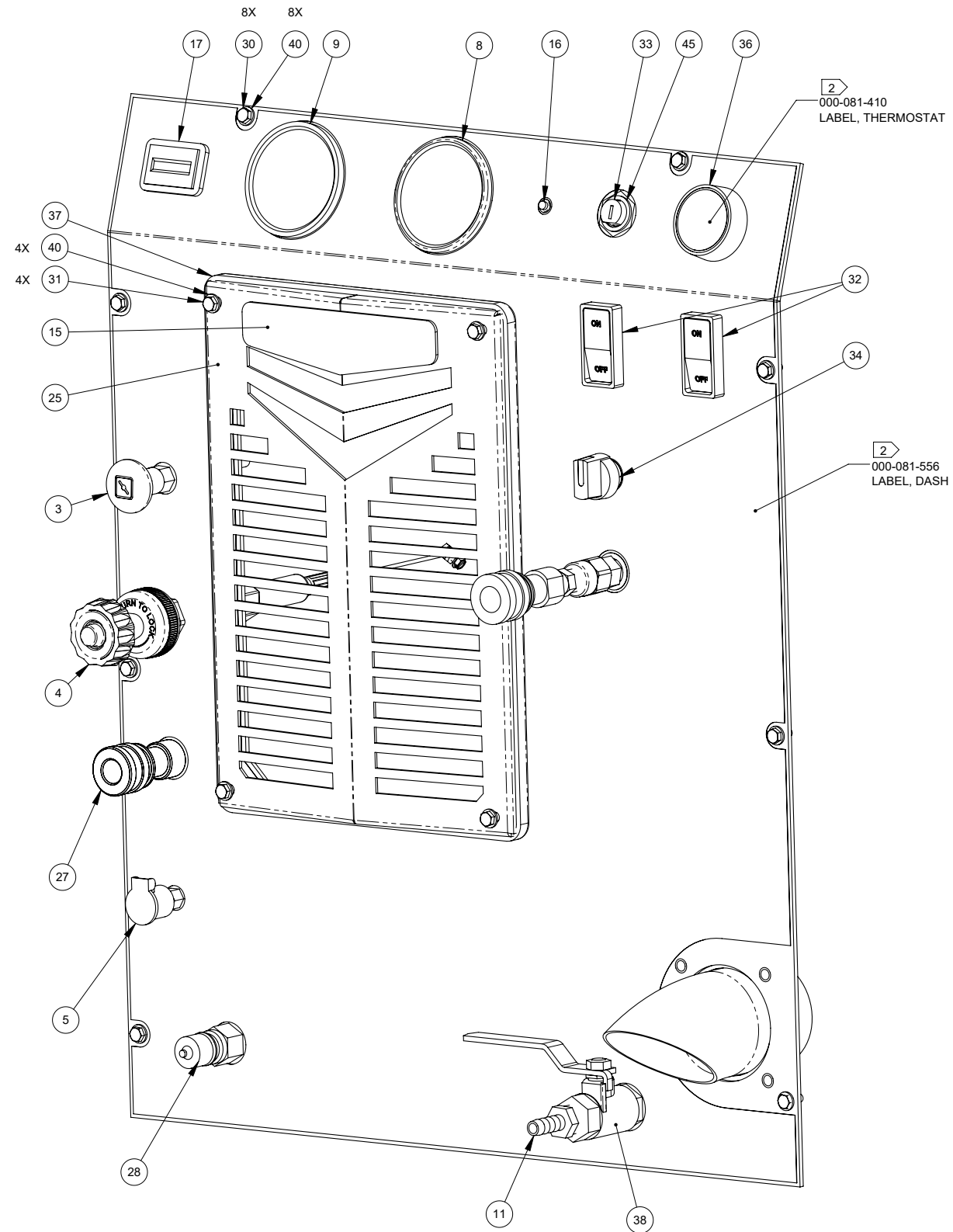
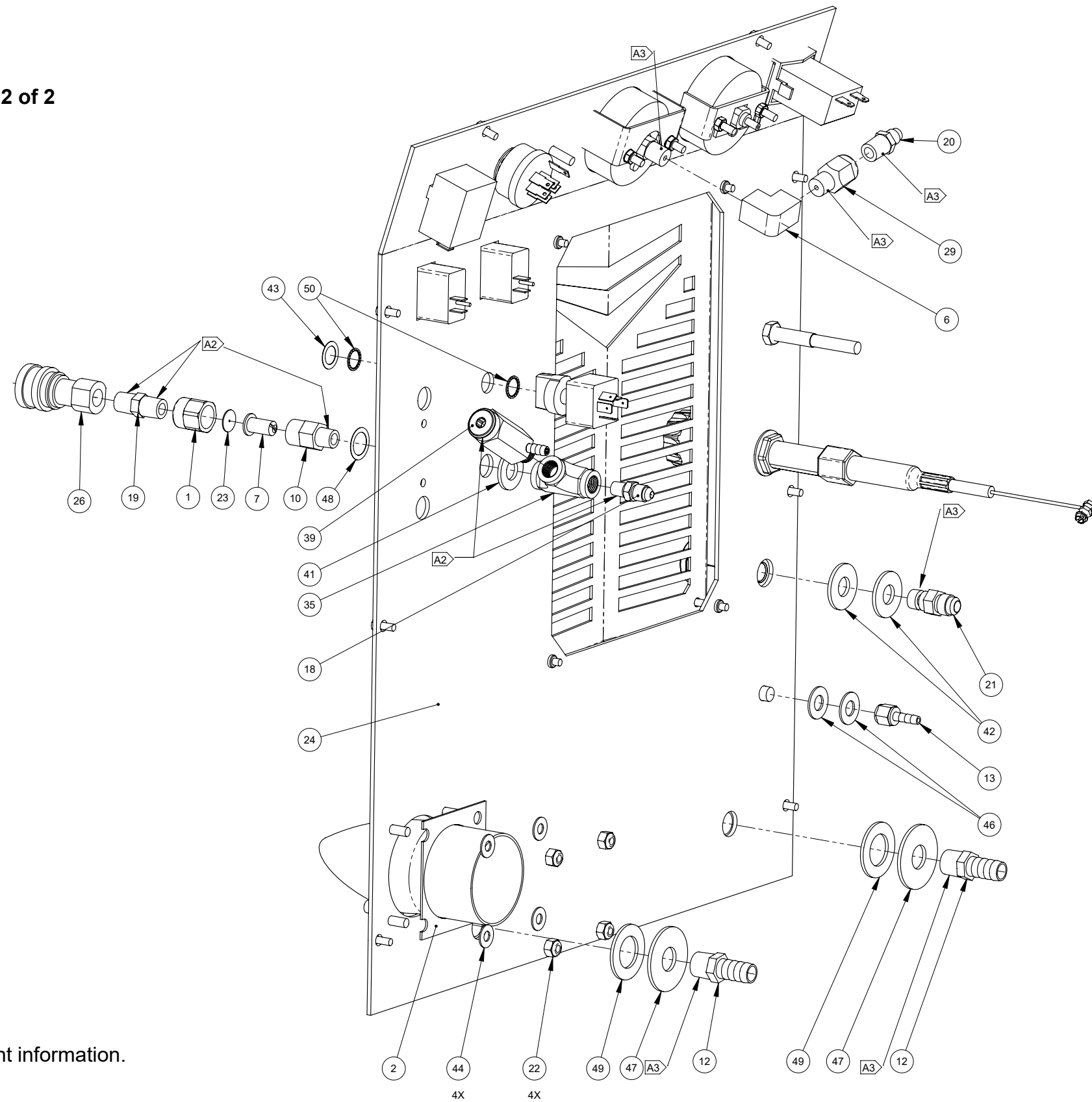


Figure 8-15. Dash Assembly - View 2 of 2
610-018-749 Rev. B



NOTICE

See Figure 8-1 for adhesive/sealant information.



Dash Assembly Parts List

Item	Part Number	Description	Qty	Item	Part Number	Description	Qty
1	000-052-804	ADAPTER, S.S. JET X 1/4" FNPT	1	24	000-100-391	PANEL, DASH - COATED E01	1
2	000-001-148	ADAPTER, 2.5" EXHAUST TURNDOWN - COATED	1	25	000-100-390	PANEL, GRILL - TITAN 325/425	1
3	000-025-003	CABLE, CHOKE WITH DETENT	1	26	000-052-690	QUICK CONNECT, 1/4" FEMALE S/S	1
4	000-025-032	CABLE, THROTTLE - MODIFIED 403	1	27	000-052-051	QUICK CONNECT, 440 FEMALE w/ EPDM O-RING	1
5	000-052-272	CUP, GRAVITY FEED OIL BLOWER LUBE PORT	1	28	000-052-052	QUICK CONNECT, 660 3/8" BRASS W/ EPDM O-RING	1
6	000-052-088	ELBOW, 1/4" FPT x FPT	1	29	000-135-052	REGULATOR, HI PSI SNUBBER	1
7	000-049-253	FILTER CARTRIDGE, 1/4" SS	1	30	000-143-126	SCREW, #10-24UNC x 0.50" LG. HEX HEAD	8
8	000-074-007	GAUGE, PRESSURE 0 -1500 PSI, UPC #401406.	1	31	000-143-171	SCREW, #10-24UNC x 1.25" LG. HEX HEAD	4
9	000-074-017	GAUGE, 30" HG. VACUUM - HYDRAMASTER	1	32	000-157-060	SWITCH, ROTARY, 4 POSITION	1
10	000-052-803	HOUSING, 1/4" S.S. FILTER	1	33	000-157-040	SWITCH, 20 AMP ROCKER	2
11	000-052-104	INSERT, #66 (3/8" NPT x 3/8" BARB)	1	34	000-157-017	SWITCH, IGNITION - B & S	1
12	000-052-105	INSERT, #68 (3/8" NPT x 1/2" BARB)	2	35	000-052-189	TEE, 1/4" FEMALE SS	1
13	000-052-096	INSERT, #F23 (1/8" FPT x 3/16" BARB)	1	36	000-149-025	THERMOSTAT, BULB & CAPILLARY	1
14	000-081-555	LABEL SET - CTS 403 FLEX	1	37	000-131-131	TRIMLOK, 3/8" x 1/8" RUBBER	3.33'
15	000-131-131	LABEL, DOME - 403	1	38	000-169-064	VALVE, 3/8" NPT FULL PORT BALL	1
16	000-084-011	LIGHT, RED LED INDICATOR MINI	1	39	000-169-243	VALVE, 3000 PSI POP OFF	1
17	000-074-170	METER, RECTANGULAR HOUR w/o BEZEL	1	40	000-174-001	WASHER, #10 FLAT	12
18	000-052-526	NIPPLE, 1/4" NPT x 1/4" JIC	1	41	000-174-007	WASHER, 1/2" FLAT	2
19	000-052-095	NIPPLE, 1/4" S/S HEX	1	42	000-174-003	WASHER, 1/4" FLAT S/S	4
20	000-052-527	NIPPLE, 1/4" SAE x 1/4" NPT	1	43	000-174-058	WASHER, 21/32" I.D. x 27/32" O.D. NYLON	1
21	000-052-533	NIPPLE, 3/8" JIC x 1/4" NPT	1	44	000-174-032	WASHER, 3/8" FLAT	2
22	000-094-009	NUT, 1/4"-20UNC NYLOCK	4	45	000-174-008	WASHER, 5/8" FLAT	4
23	000-180-031	ORIFICE, PLATE 0.052"	1				

Figure 8-16. Engine Assembly - Part 1 of 2
610-004-749 Rev. A

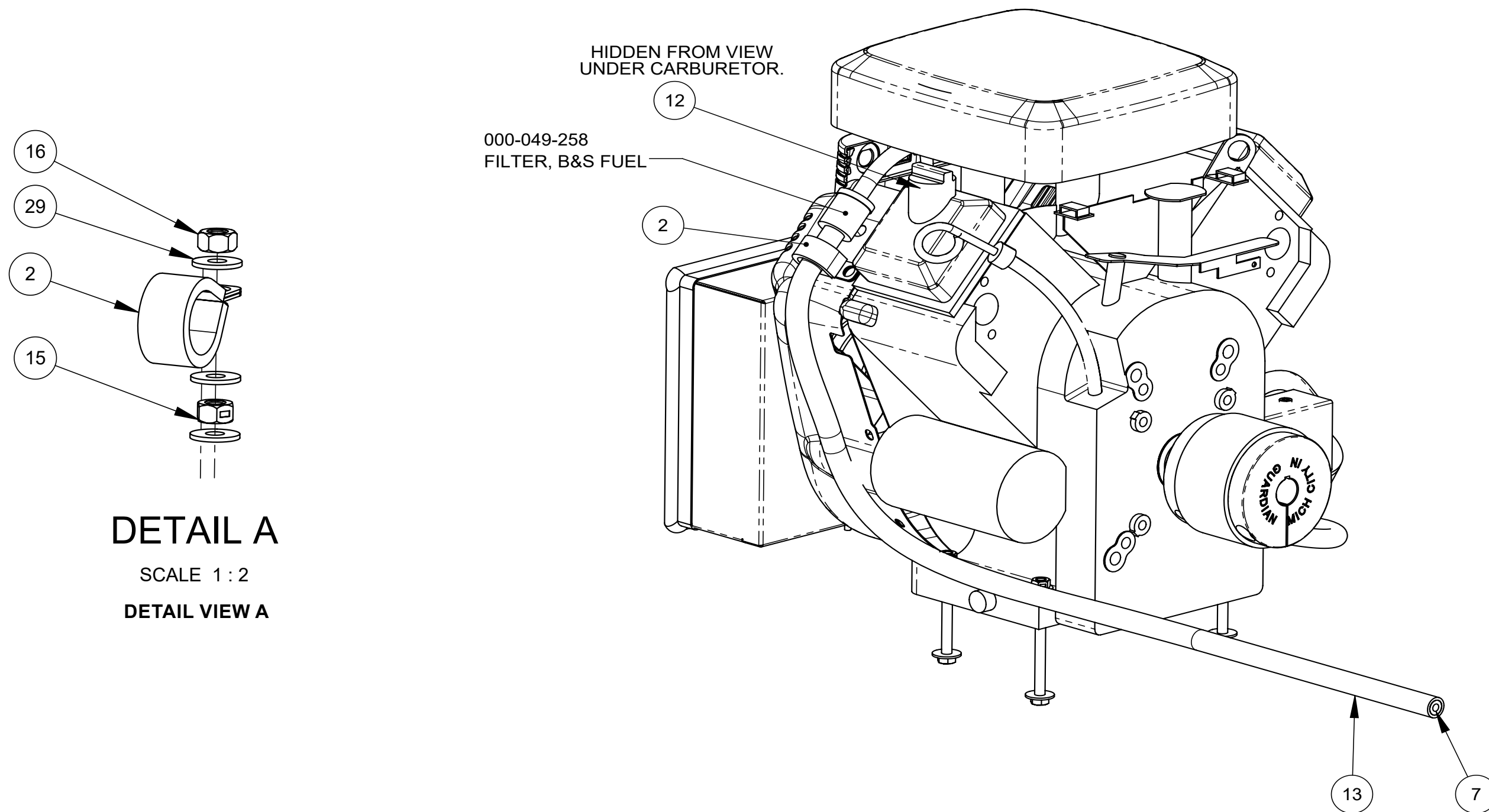
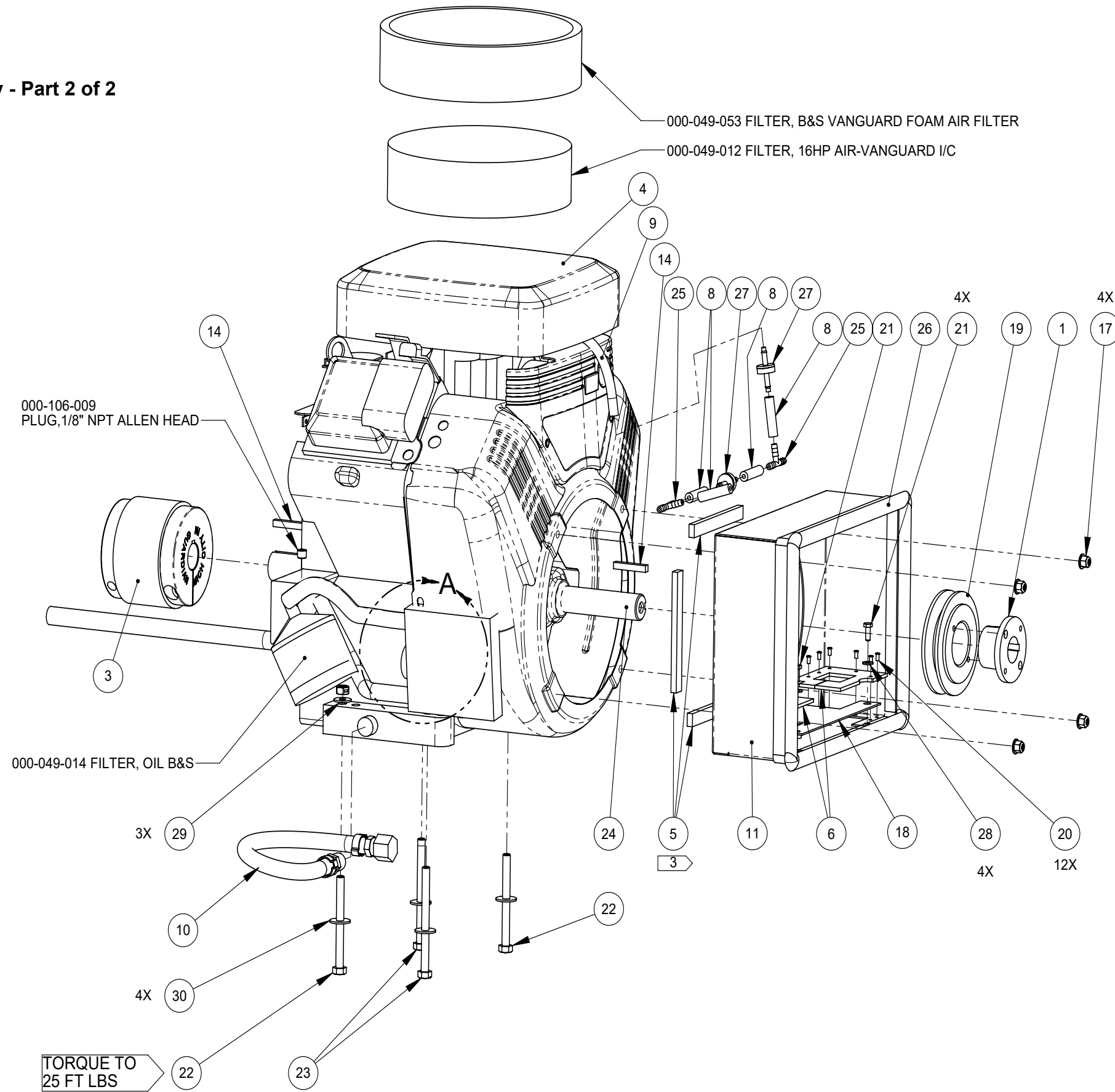


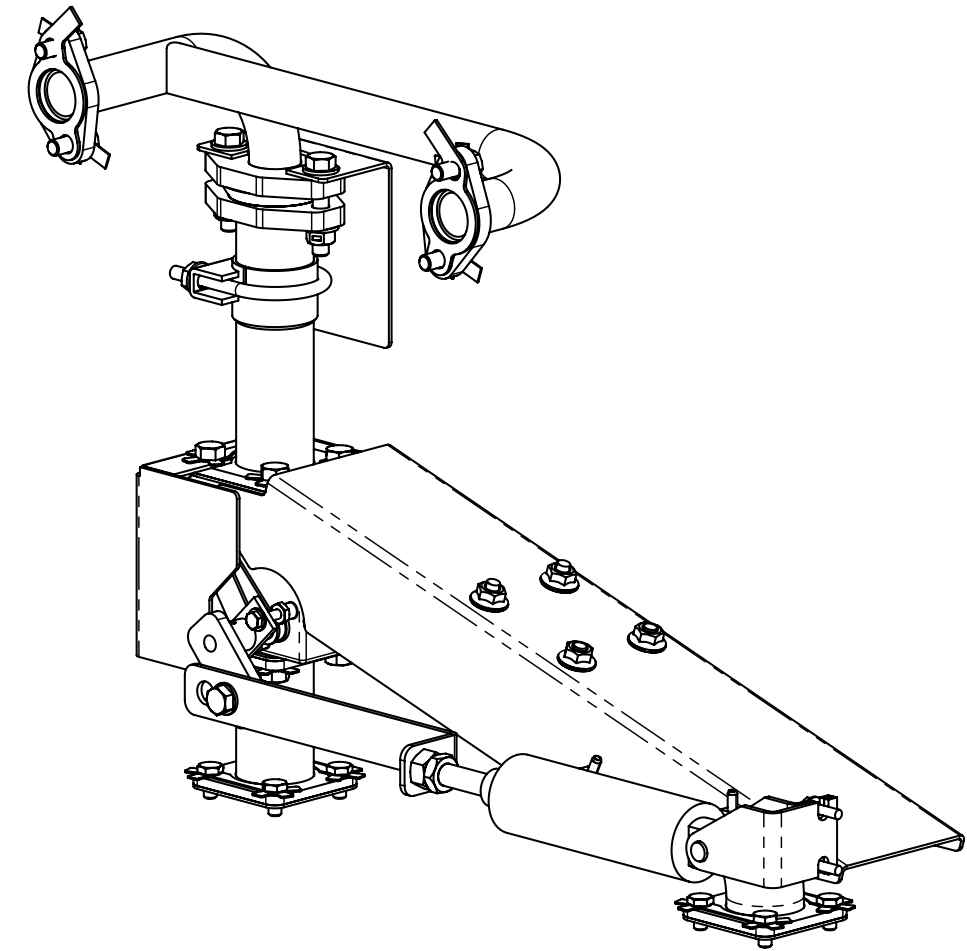
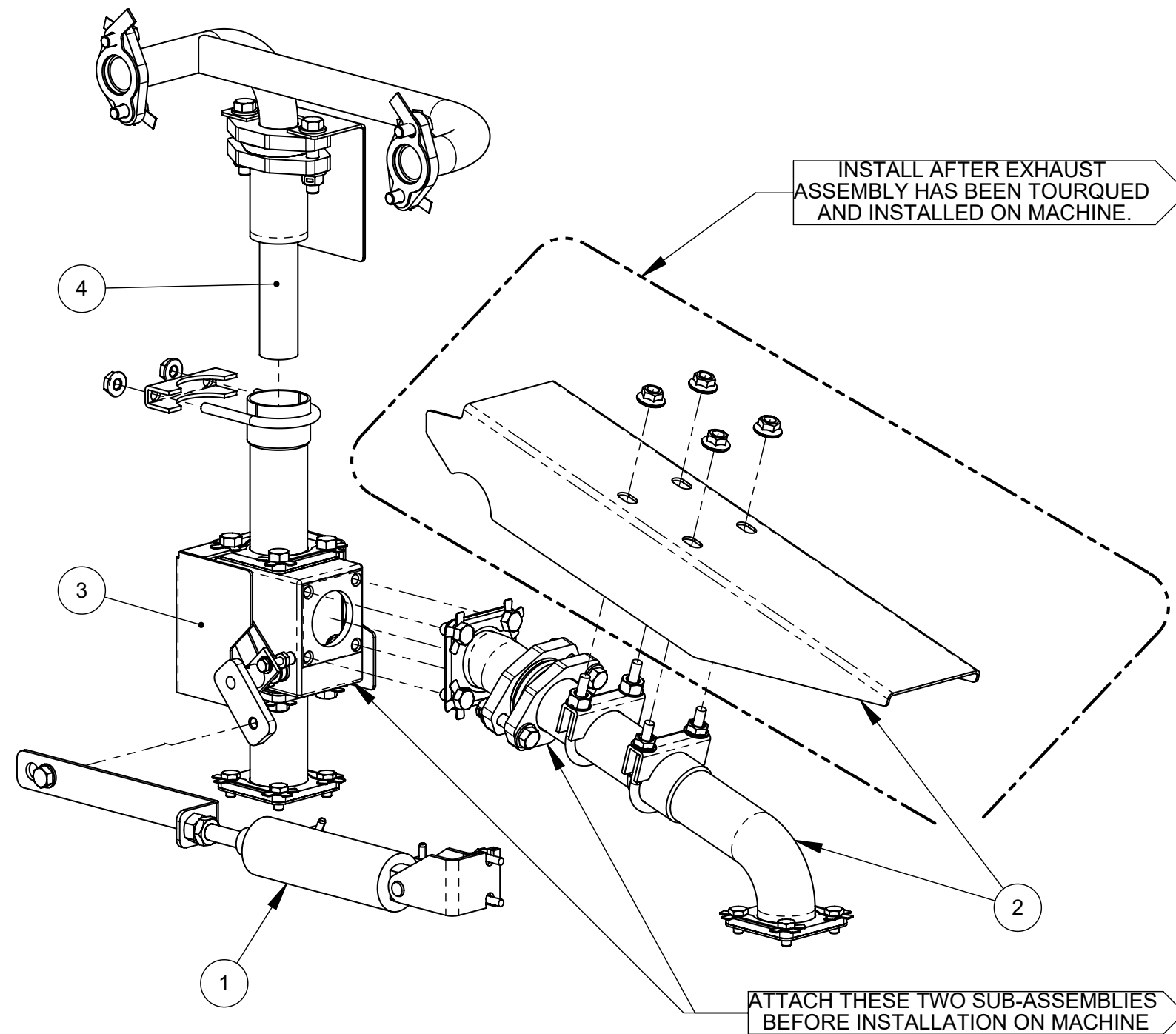
Figure 8-17. Engine Assembly - Part 2 of 2
610-004-749 Rev. A



Engine Assembly Parts List

Item	Part Number	Description	Qty	Item	Part Number	Description	Qty
1	000-020-025	BUSHING, H X 1"	1	16	000-094-012	NUT, 5/16"-18UNC HEX	1
2	000-033-117	CLAMP, 1" CUSHION LOOP w/ 7/16 MOUNT HOLE	2	17	000-094-125	NUT, 6MM HEX NYLOCK FLANGE S/S	4
3	000-039-060	COUPLER, GUARDIAN 7/8" X 1" BORE - 18/23 HP	1	18	000-105-562	PLATE, ENGINE DUCT - COATED	1
4	000-047-037	ENGINE, B&S 23HP	1	19	000-109-040	PULLEY, AK47-H	1
5	000-057-026	GASKET, 1/2" X 1/4" X 18-1/8" LG.	2	20	000-140-001	RIVET, AB4-3A ALUMINUM POP 1/8" x 1/4" LG.	12
6	000-057-226	GASKET, ENGINE DUCT	2	21	000-143-126	SCREW, #10-24UNC x 0.50" LG. HEX HEAD	4
7	000-068-979	HOSE, 1/4" I.D. FUEL LOW PERM x 120" LG.	1	22	000-143-659	SCREW, 5/16"-18UNC X 3.5" LG. GRADE 8	2
8	000-068-1006	HOSE, 5/32" I.D. RUBBER/VACUUM X 1.5" LG.	4	23	000-143-660	SCREW, 5/16"-18UNC X 4.0" LG., HEX HEAD	2
9	000-068-1007	HOSE, 5/32" RUBBER VAC X 4.5" LG	1	24	000-150-169	SHAFT, B&S 23HP STUB	1
10	000-068-219	HOSE, DRAIN	1	25	000-052-155	TEE, 3/16" PLASTIC VACUUM INSERT	2
11	000-042-074	HOUSING, RADIATOR DUCT - COATED	1	26	000-131-060	TRIMLOK, 3/4" BULB x 3/16" OPENING (40" LG.)	3.33'
12	000-052-293	INSERT, #23 (1/8" NPT x 3/16" BARB)	1	27	000-169-156	VALVE, CHECK - DIVERTER CONTROL	2
13	000-131-139	INSULATION, 1" HI-TEMP ALUM SLEEVE x 60" LG.	1	28	000-174-001	WASHER, #10 FLAT	4
14	000-077-010	KEY, 1/4" x 1-1/2" LG. CLASS 2 FIT	2	29	000-174-002	WASHER, 1/4" FLAT	6
15	000-094-081	NUT, 5/16"-18UNC HEX 2 WAY LOCKING	4	30	000-174-004	WASHER, 5/16" FLAT, USS	4

Figure 8-18. Exhaust Assembly
610-013-749 Rev. A



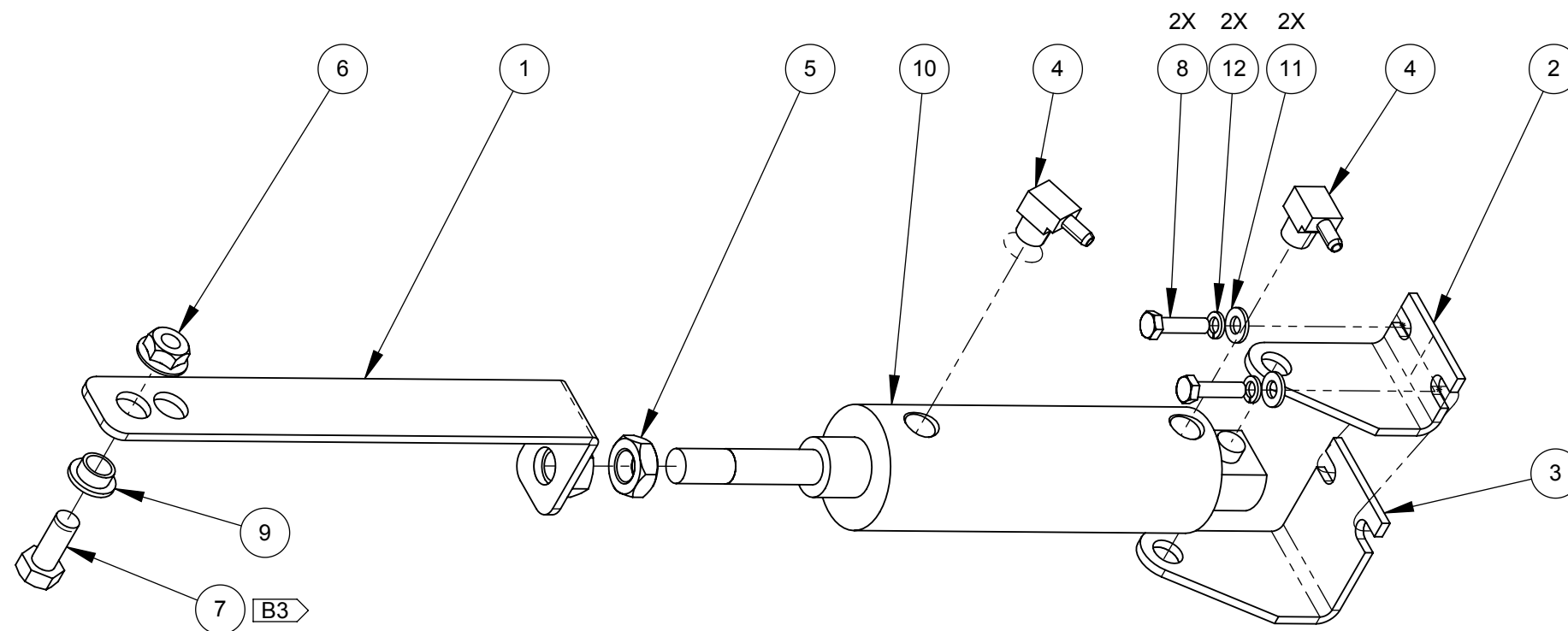
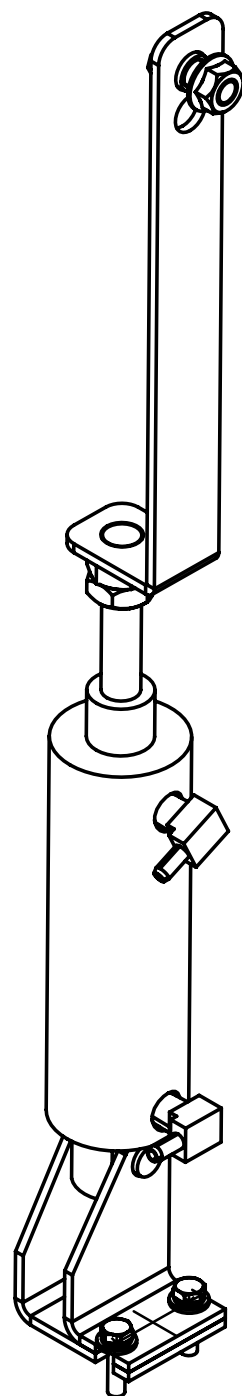
Exhaust Assembly Parts List

Item	Part Number	Description	Qty
1	610-014-728	ASSEMBLY, DIVERTER VALVE ACTUATOR	1
2	610-013-007	ASSEMBLY, EXHAUST DIVERTED - CTS 403 FLEX	1
3	610-013-010	ASSEMBLY, EXHAUST DIVERTER VALVE - CTS 403	1
4	610-013-009	ASSEMBLY, EXHAUST MANIFOLD - CTS 403	1

NOTICE

See Figure 8-1 for adhesive/sealant information.

Figure 8-19. Diverter Valve Actuator Assembly
610-014-728 Rev. F



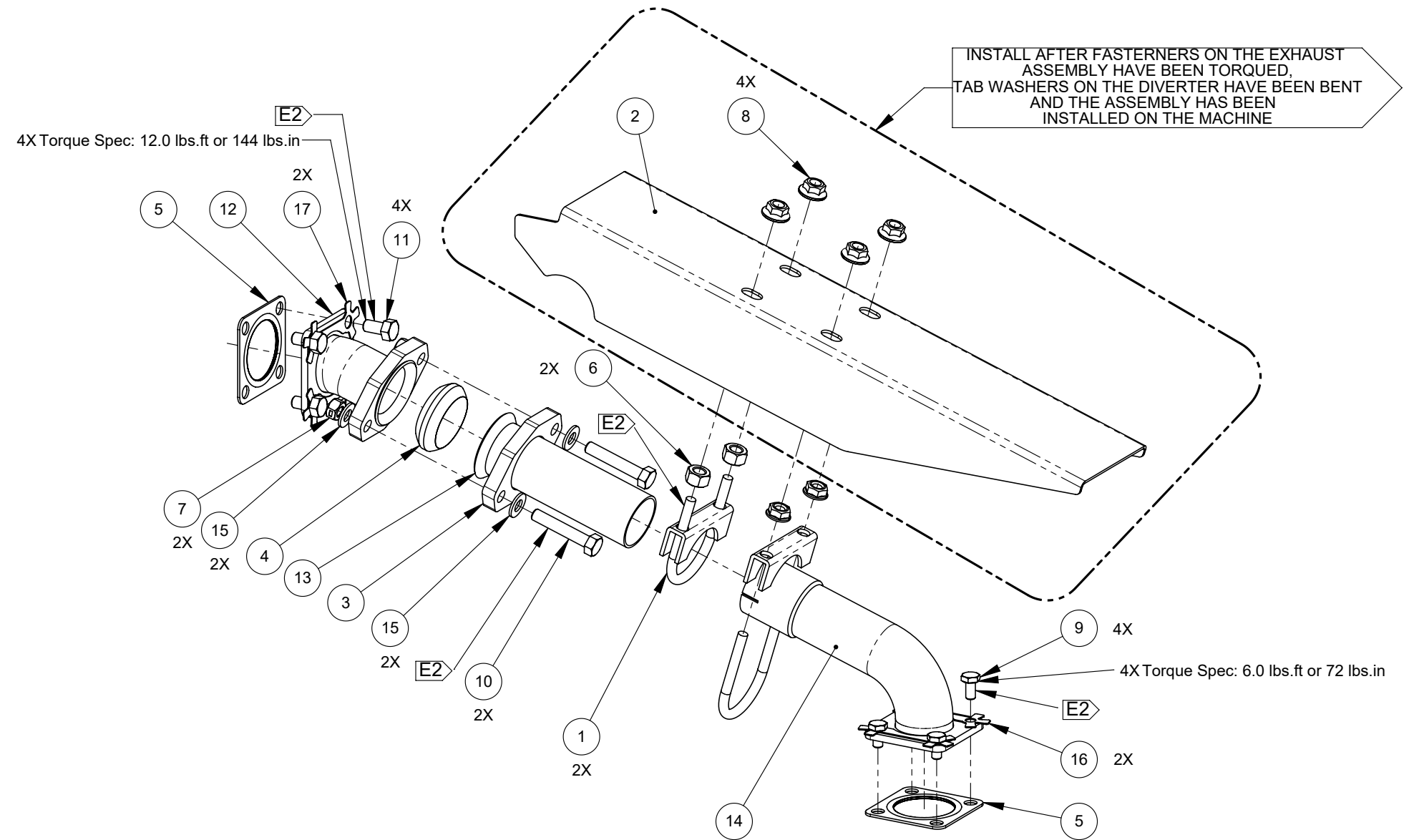
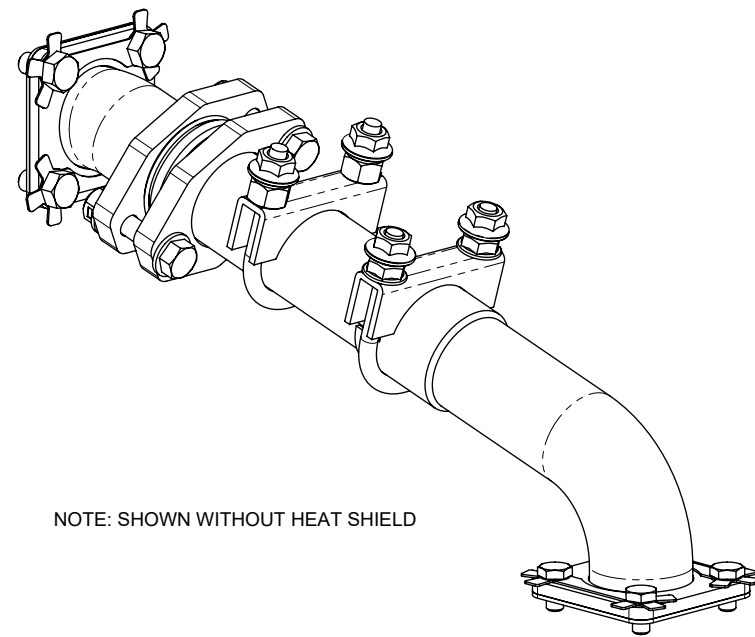
NOTICE

See Figure 8-1 for sealant information.

Diverter Valve Actuator Assembly Parts List

Item	Part Number	Description	Qty
1	000-015-016	Bracket Actuator - Coated	1
2	000-015-750	Bracket, Air Cylinder Mount - Inner Coated	1
3	000-015-748	Bracket, Air Cylinder Mount - Outer - Coated	1
4	000-052-106	Insert, 1/8" NPT X 5/32" Barb X 90 Degree	2
5	000-094-092	Nut, 7/16"-20UNF Hex Jam	1
6	000-094-117	Nut, 5/16"-18UNC Hex Spirallock	1
7	000-143-012	Screw, 5/16"-18UNC X 3/4" Lg.	1
8	000-143-132	Screw, #10-24UNC X 0.75" Lg. Hex Head	2
9	000-154-207	Spacer, Ø0.625 X 0.25" Lg. Flanged	1
10	000-169-169	Valve, Air Cylinder	1
11	000-174-001	Washer, #10 Flat	2
12	000-174-014	Washer, #10 Lock	2

Figure 8-20. Exhaust Diverted Assembly
610-013-007 Rev. C



NOTICE

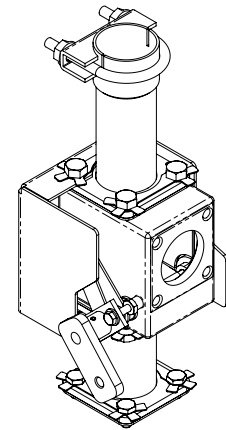
See Figure 8-1 for adhesive/sealant information.

Exhaust Diverted Assembly Parts List

Item	Part Number	Description	Qty
1	000-033-068	CLAMP, 1-1/2" EXHAUST	2
2	000-041-043	COVER, DIVERTER EXHAUST	1
3	000-105-181	FLANGE, Ø1.50" EXHAUST DONUT - COATED	1
4	000-057-199	GASKET, EXHAUST DONUT	1
5	000-057-146	GASKET, FOUR HOLE EXHAUST	2
6	000-094-016	NUT, 3/8"-16UNC HEX WHIZ LOCK	2
7	000-094-081	NUT, 5/16"-18UNC HEX 2 WAY LOCKING	2
8	000-094-078	NUT, 5/16"-18UNC HEX FLANGE	4
9	000-143-758	SCREW, 1/4-20 X 1/2" GD8 ZINC HHC	4

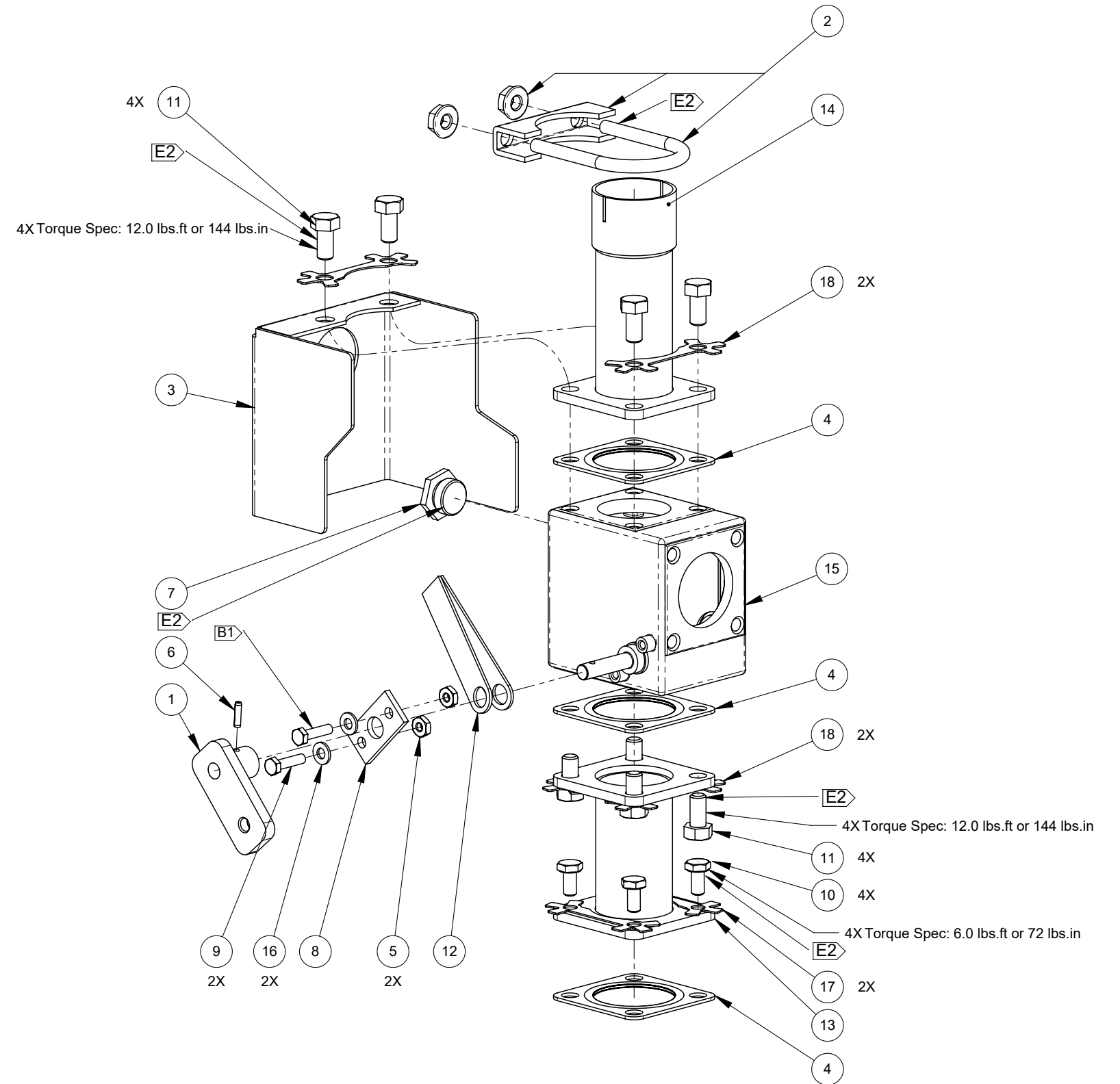
Item	Part Number	Description	Qty
10	000-143-124	SCREW, 5/16"-18UNC x 1.75" LG. HEX HEAD	2
11	000-143-572	SCREW, 5/16"-18UNC x 5/8" LG. GRD. 5 HEX HEAD	4
12	000-125-199	TUBE, EXHAUST DIVERT - WELDMENT	1
13	000-125-266	TUBE, EXHAUST 4.60" LG. W/ FLARE	1
14	000-125-940	TUBE, EXHAUST DIVERT - WELDMENT	1
15	000-174-049	WASHER, 5/16" FLAT	4
16	000-174-209	WASHER, 1/4" TAB PLENUM BOX	2
17	000-174-208	WASHER, 5/16" TAB DIVERTER BOX	2

Figure 8-21. Exhaust Diverter Valve Assembly
610-013-010 Rev. A



Exhaust Diverter Valve Assembly Parts List

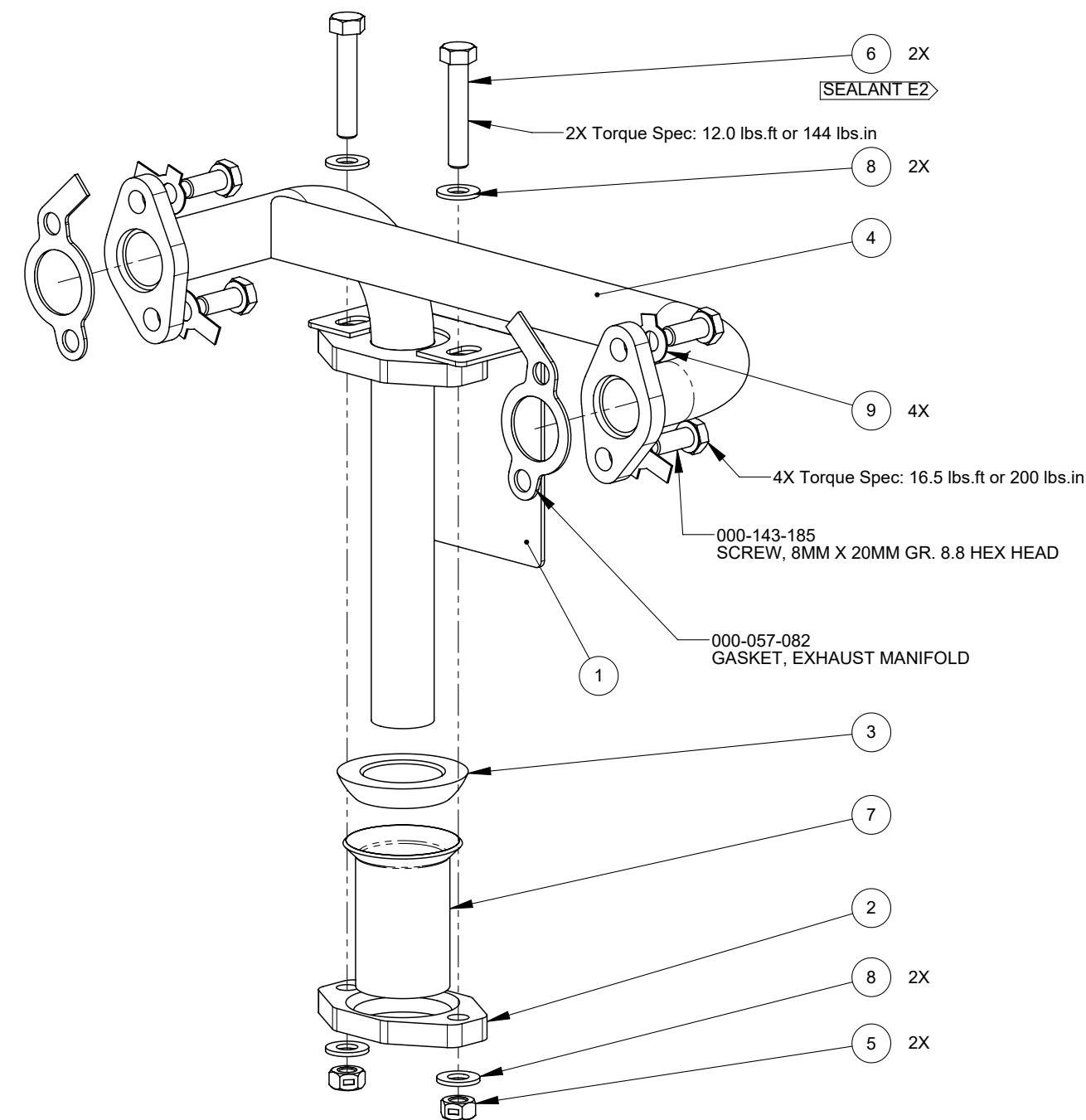
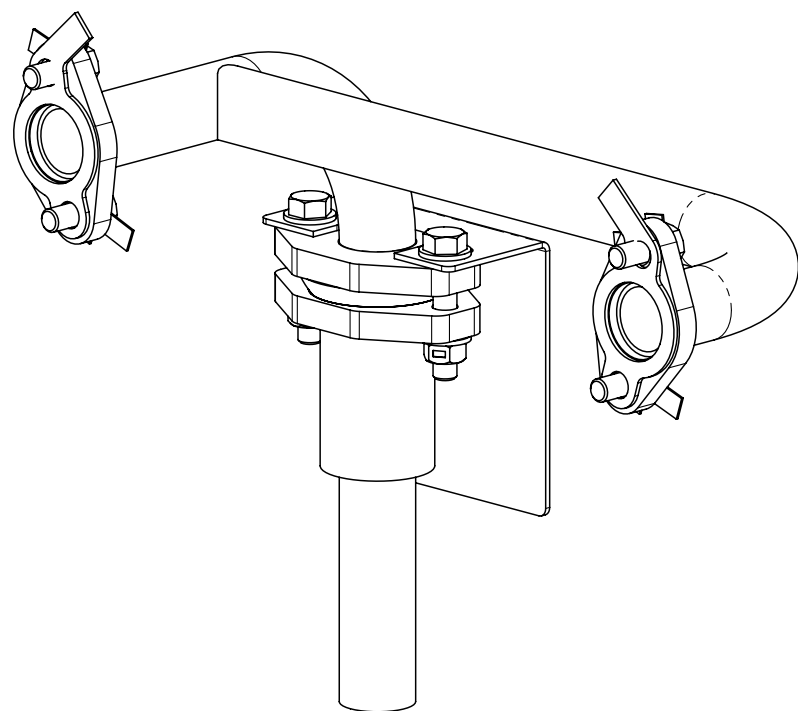
Item	Part Number	Description	Qty
1	000-015-642	BRACKET, AIR CYLINDER ACTUATION - COATED	1
2	000-033-068	CLAMP, 1-1/2" EXHAUST	1
3	000-041-031	COVER, DIVERTER	1
4	000-057-146	GASKET, FOUR HOLE EXHAUST	3
5	000-094-027	NUT, #10-24UNC HEX	2
6	000-103-005	PIN, ROLL - 0.125" x 0.500" LG.	1
7	000-106-120	PLUG, M18 x 1.5	1
8	000-138-010	RETAINER, LEAF SPRING	1
9	000-143-132	SCREW, #10-24UNC x 0.75" LG. HEX HEAD	2
10	000-143-758	SCREW, 1/4-20 X 1/2" GD8 ZINC HHC	4
11	000-143-572	SCREW, 5/16"-18UNC x 5/8" LG. GRD. 5 HEX HEAD	8
12	000-155-030	SPRING, LEAF - WELDMENT	1
13	000-125-139	TUBE EXHAUST - WELDMENT	1
14	000-125-268	TUBE EXHAUST - WELDMENT	1
15	000-169-045	VALVE, CAST EXHAUST DIVERTER	1
16	000-174-001	WASHER, #10 FLAT	2
17	000-174-209	WASHER, 1/4" TAB PLENUM BOX	2
18	000-174-208	WASHER, 5/16" TAB DIVERTER BOX	4



NOTICE

See Figure 8-1 for adhesive/sealant information.

Figure 8-22. Exhaust Manifold Assembly
610-013-008 Rev. B



Exhaust Manifold Assembly Parts List

Item	Part Number	Description	Qty
1	000-041-854	COVER, UPPER EXH SHIELD - FAB	1
2	000-105-181	FLANGE, Ø1.50" EXHAUST DONUT - COATED	1
3	000-057-212	GASKET, HALF DONUT	1
4	000-090-001	MANIFOLD, EXHAUST - WELDMENT	1
5	000-094-081	NUT, 5/16"-18UNC HEX 2 WAY LOCKING	2
6	000-143-124	SCREW, 5/16"-18UNC x 1.75" LG. HEX HEAD	2
7	000-125-307	TUBE, EXHAUST 2.406" LG. W/ FLARE	1
8	000-174-049	WASHER, 5/16" FLAT	4
9	000-174-166	WASHER, 5/16" TAB	4

NOTICE

See Figure 8-1 for adhesive/sealant information.

Figure 8-23. Frame Assembly - View 1 of 2
610-001-749 Rev. B

NOTICE

See Figure 8-1 for adhesive/sealant information.

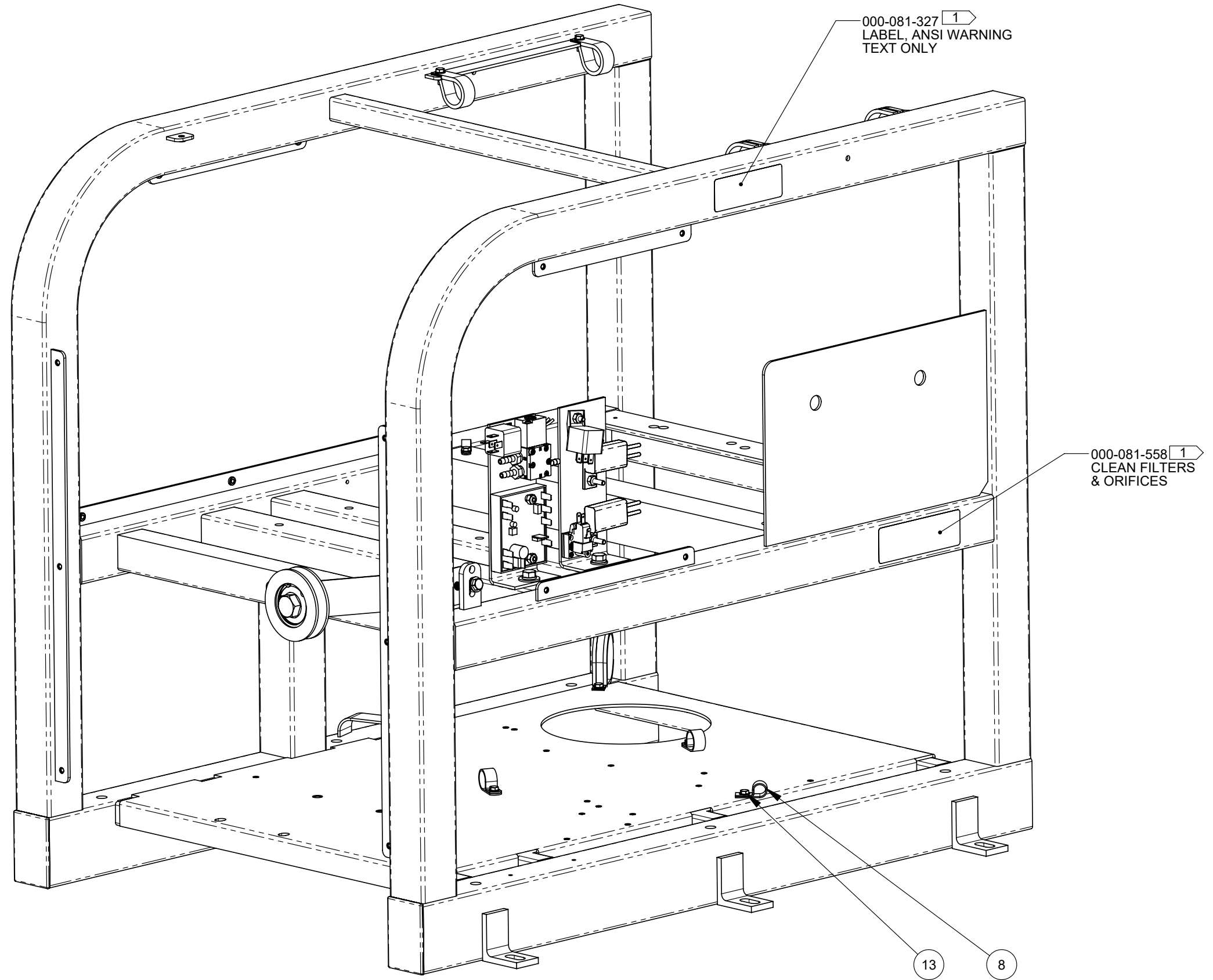
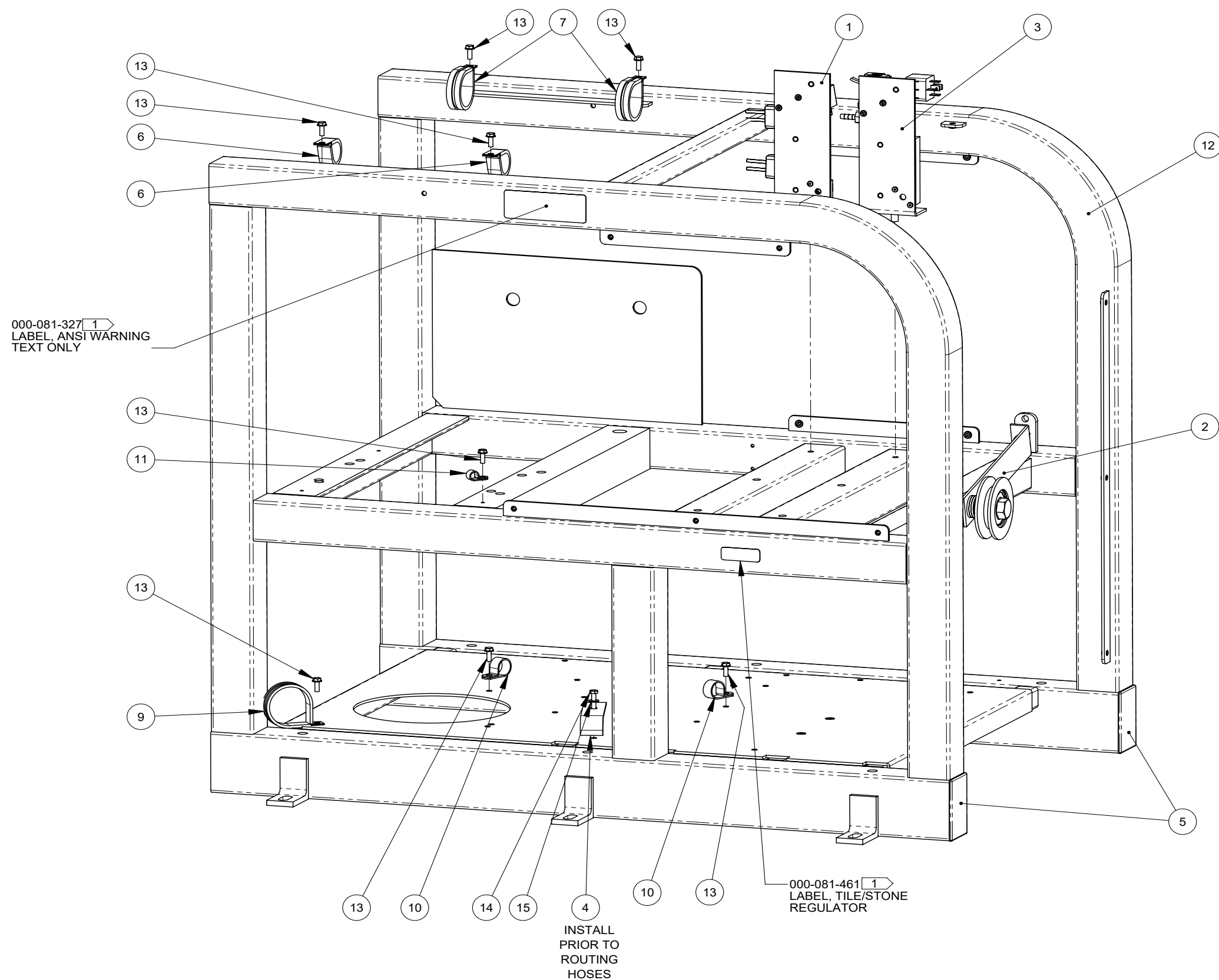


Figure 8-24. Frame Assembly - View 2 of 2
610-001-749 Rev. B



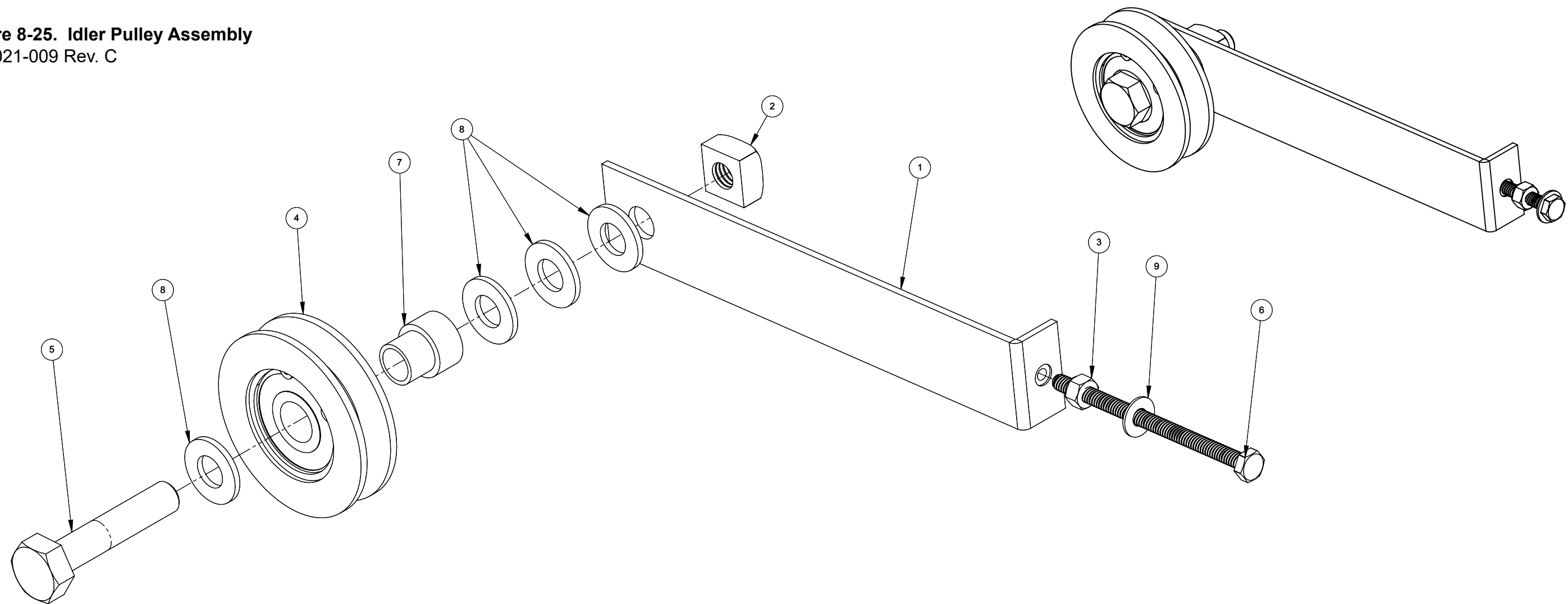


Frame Assembly Parts List

Item	Part Number	Description	Qty
1	610-021-749	ASSEMBLY, BACK PRESSURE SWITCH MOUNT	1
2	610-021-009	ASSEMBLY, IDLER PULLEY	1
3	610-026-747	ASSEMBLY, SOLENOID VALVE - CTS 403 FLEX	1
4	000-015-1304	BRACKET, HOSE TIE DOWN	1
5	000-027-110	CAP, 2" X 3" FRAME END	2
6	000-033-057	CLAMP, 1" CUSHION LOOP	2
7	000-033-050	CLAMP, 1-3/4" CUSHION LOOP	2
8	000-033-046	CLAMP, 1/2" WIDE X 1/2" TUBE	1

Item	Part Number	Description	Qty
9	000-033-067	CLAMP, 2" CUSHION LOOP	1
10	000-033-134	CLAMP, 3/4 ID, CUSHION	2
11	000-033-128	CLAMP, 3/8" NYLON HOSE	1
12	000-055-195	FRAME, COMPLETE - COATED	1
13	000-143-583	SCREW, #10-24UNC x 0.50" LG. HEX H FLANGE Z/P	9
14	000-143-065	SCREW, #10-24UNC x 1.75" LG. HEX HEAD	1
15	000-174-001	WASHER, #10 FLAT	1

Figure 8-25. Idler Pulley Assembly
610-021-009 Rev. C



Idler Pulley Assembly Parts List

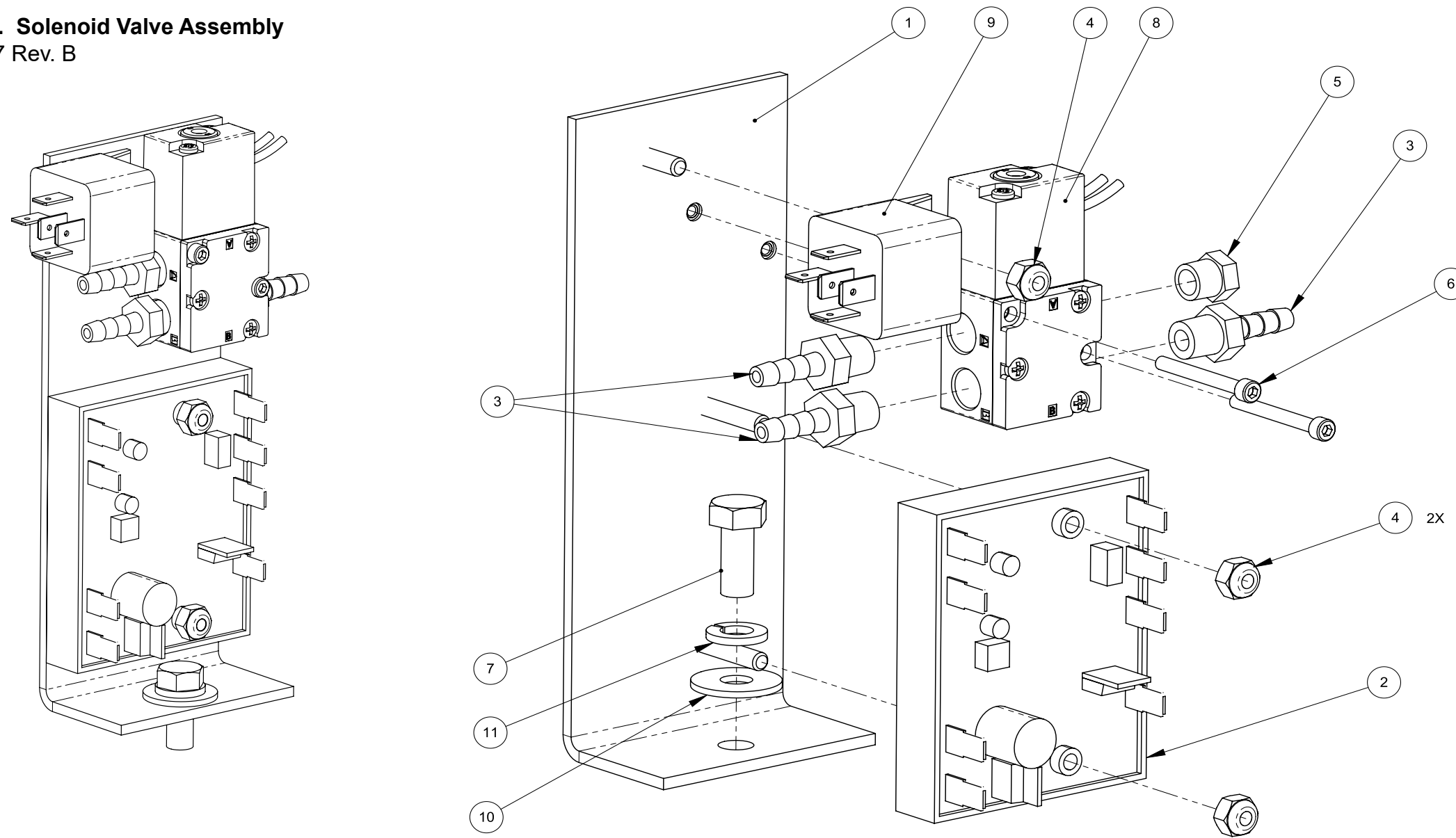
Item	Part Number	Description	Qty
1	000-015-942	Bracket, Idler Tension - Coated	1
2	000-094-119	Nut, 1/2"-13UNC Square Z/P	1
3	000-094-009	Nut, 1/4"-20UNC Nylock	1
4	000-109-093	Pulley, 3" "A" Sect. Ball Bearing Assembly	1
5	000-143-716	Screw 1/2-13 X 2-1/2 HHC Zinc	1

Item	Part Number	Description	Qty
6	000-143-376	Screw, 1/4"-20UNC X 4.00" Lg. S/S- Full Thread	1
7	000-154-049	Spacer, Pump Idler Mounting - Coated	1
8	000-174-012	Washer, 1/2 SAE H/D	4
9	000-174-003	Washer, 1/4" Flat	1

NOTICE

* Item 8 may require a different quantity than listed due to alignment variances in the pulley system.

Figure 8-26. Solenoid Valve Assembly
610-026-747 Rev. B

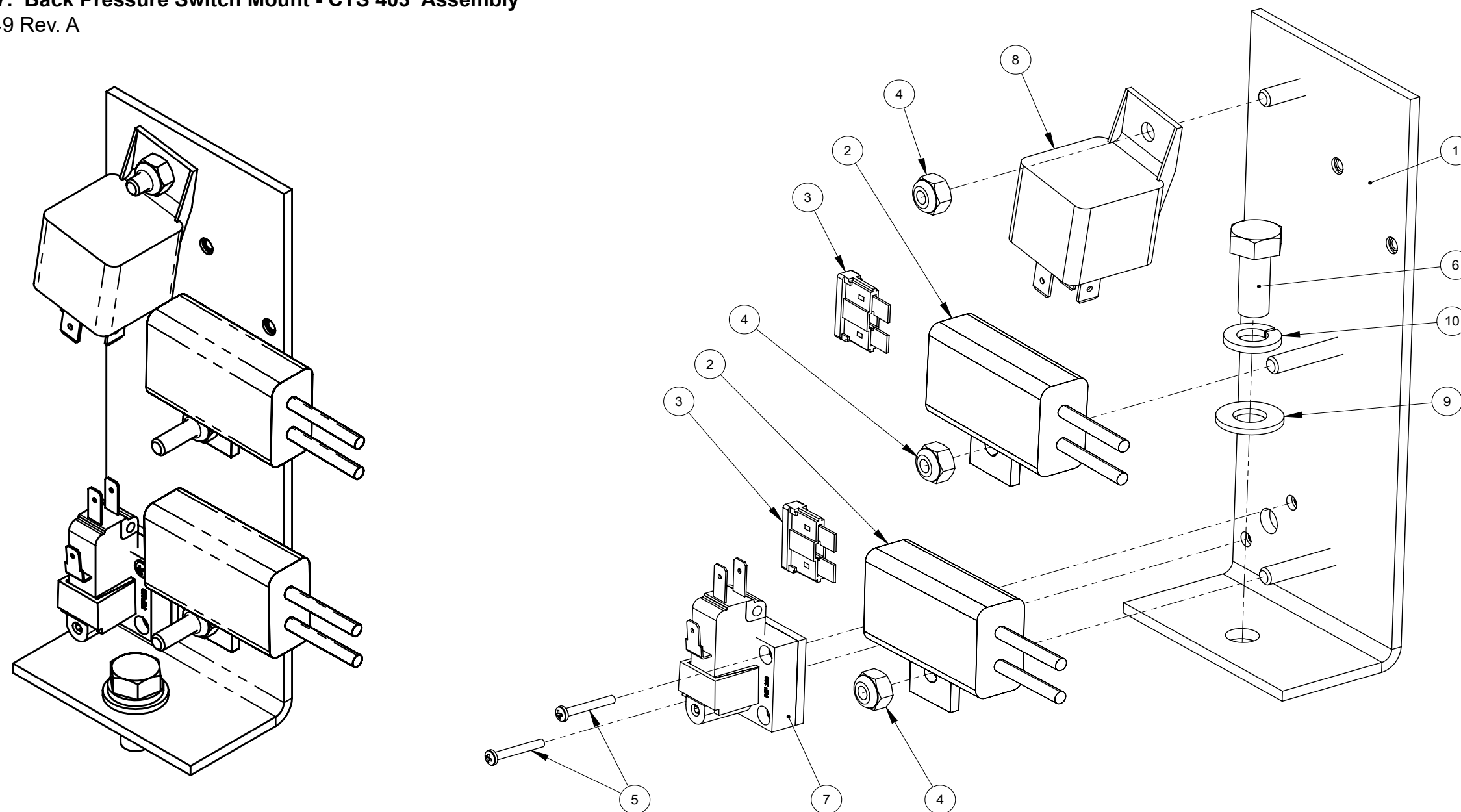


Solenoid Valve Assembly Parts List

Item	Part Number	Description	Qty
1	000-015-1295	Bracket, Temp Control - Coated	1
2	000-074-125	Controller, Temp Single Analog Input - RTD	1
3	000-052-293	Insert, #23 (1/8" NPT X 3/16" Barb)	3
4	000-094-034	Nut, #10-24UNC Hex Nylock	3
5	000-106-014	Plug, Vent	1
6	000-143-700	Screw, #6-32UNC X 1.25" Lg. Socket Head	2

Item	Part Number	Description	Qty
7	000-143-012	Screw, 5/16"-18UNC X 3/4" Lg.	1
8	000-169-226	Solenoid, Air Actuator 4- Way Valve	1
9	000-157-022	Switch, Relay	1
10	000-174-004	Washer, 5/16" Flat, USS	1
11	000-174-018	Washer, 5/16" Lock	1

Figure 8-27. Back Pressure Switch Mount - CTS 403 Assembly
610-021-749 Rev. A

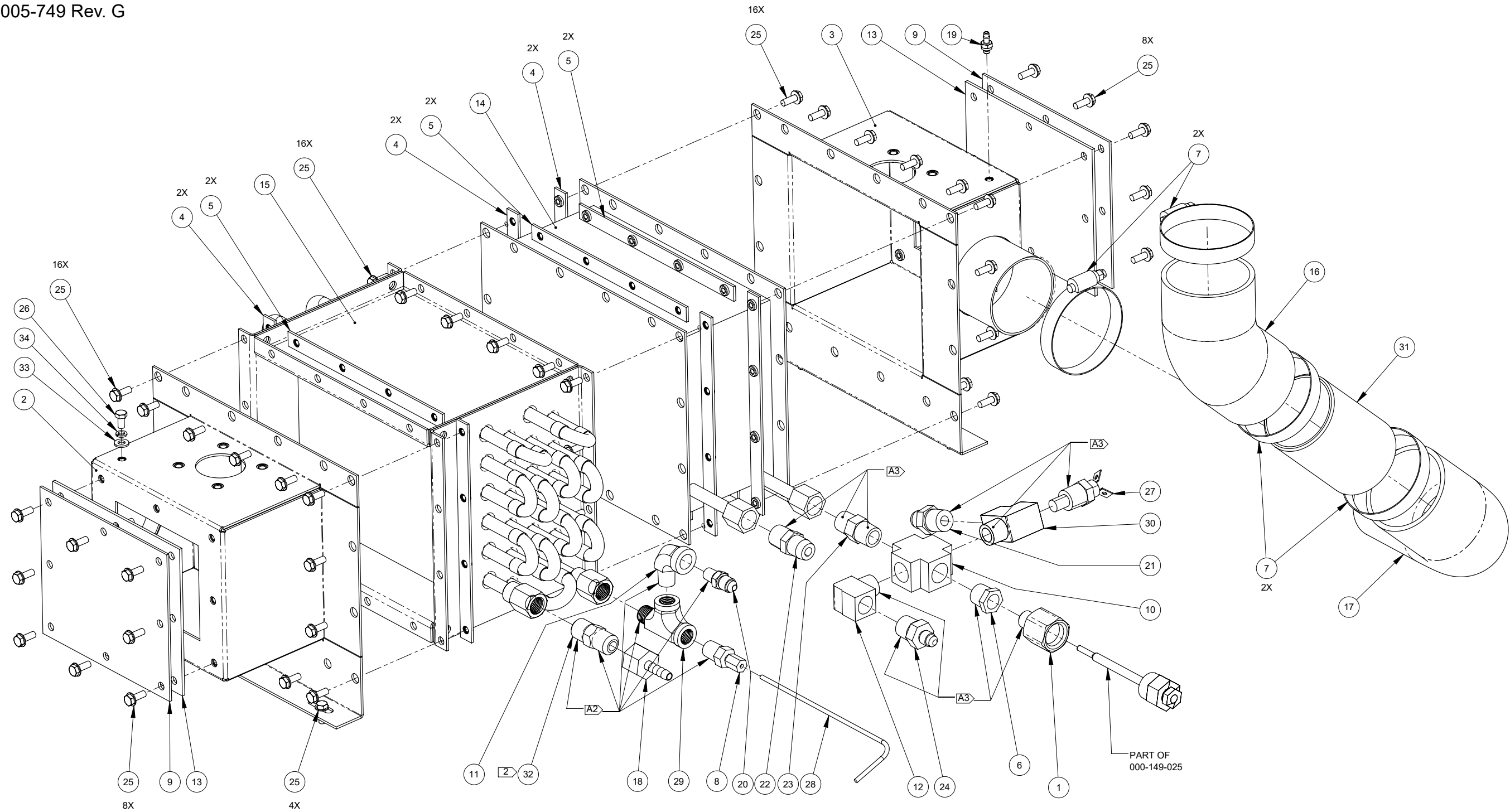


Back Pressure Switch Mount - CTS 403 Assembly Parts List

Item	Part Number	Description	Qty
1	000-015-1295	BRACKET, TEMP CONTROL - COATED	1
2	000-056-006	FUSE HOLDER, IN-LINE - WEATHERPROOF	2
3	000-056-010	FUSE, 25 AMP	2
4	000-094-034	NUT, #10-24UNC HEX NYLOCK	3
5	000-143-788	SCREW, #2-56UNC X 5/8" LG. PAN PHILLIPS S/S	2

Item	Part Number	Description	Qty
6	000-143-012	SCREW, 5/16"-18UNC x 3/4" LG. HEX HEAD	1
7	000-157-172	SWITCH, PRESSURE 1.125 PSI	1
8	000-157-022	SWITCH, RELAY 12V	1
9	000-174-049	WASHER, 5/16" FLAT	1
10	000-174-018	WASHER, 5/16" LOCK	1

Figure 8-28. Heat Exchanger Assembly
610-005-749 Rev. G



NOTICE

See Figure 8-1 for adhesive/sealant information.

Heat Exchanger Assembly Parts List

Item	Part Number	Description	Qty
1	000-052-738	ADAPTER, 1/4" NPT x 1/2" FPT	1
2	000-013-136	BOX, OUTLET PLENUM - WELDED - CTS 403	1
3	000-013-135	BOX, PLENUM CTS 403 - WELDMENT	1
4	000-015-1303	BRACKET, HX PLENUM SIDE BACKING	6
5	000-015-1302	BRACKET, HX PLENUM TOP BACKING	6
6	000-052-061	BUSHING, 3/8" NPT x 1/4" FPT	1
7	000-033-011	CLAMP, SIZE #36 HOSE	4
8	000-052-931	COMPRESSION, FITTING 1/4" NPT x 1/8" TUBE - STK	1
9	000-041-930	COVER, HX ACCESS	2
10	000-052-113	CROSS, 3/8" FPT	1
11	000-052-691	ELBOW, 1/4" NPT STREET S/S	1
12	000-052-086	ELBOW, 3/8" NPT STREET	1
13	000-057-272	GASKET, HX ACCESS COVER	2
14	000-038-072	HEAT EXCHANGER, 4 ROW 6X8	1
15	000-038-082	HEAT EXCHANGER, 4 ROW 6X8 S/S	1
16	000-068-1098	HOSE 2.5 X 45 ELBOW SILICONE MOD	1
17	000-068-1097	HOSE 2.5 X 90 ELBOW SILICONE	1
18	000-052-935	INSERT, #F46 S/S	1
19	000-052-961	INSERT, 27 MALE - 1/4" BARB X 10-32 UNF	1
20	000-052-526	NIPPLE, 1/4" NPT x 1/4" JIC	1
21	000-052-528	NIPPLE, 3/8" M JIC x 3/8" NPT	1
22	000-052-128	NIPPLE, 3/8" MPT x 3/8" SAE FLARE	1
23	000-052-074	NIPPLE, 3/8" NPT HEX	1
24	000-052-662	NIPPLE, 3/8" NPT x 1/4" M SAE	1
25	000-143-583	SCREW, #10-24UNC x 0.50" LG. HEX FLANGE Z/P	68
26	000-143-730	SCREW, #10-32UNC x 3/8" LG. HEX HEAD	1
27	000-149-027	SENSOR, 285F NASON- 3/8" NPT	1

Item	Part Number	Description	Qty
28	000-149-566	SENSOR, 6" - 90° RTD	1
29	000-052-190	TEE, 1/4" BRANCH SS	1
30	000-052-023	TEE, 3/8" NPT MALE STREET	1
31	000-125-347	TUBE, 2.5" OD x 3.5" LG. AL	1
32	000-169-589	VALVE, 3/8" HI-PSI SS - CHECK	1
33	000-174-001	WASHER, #10 FLAT	1
34	000-174-014	WASHER, #10 LOCK	1

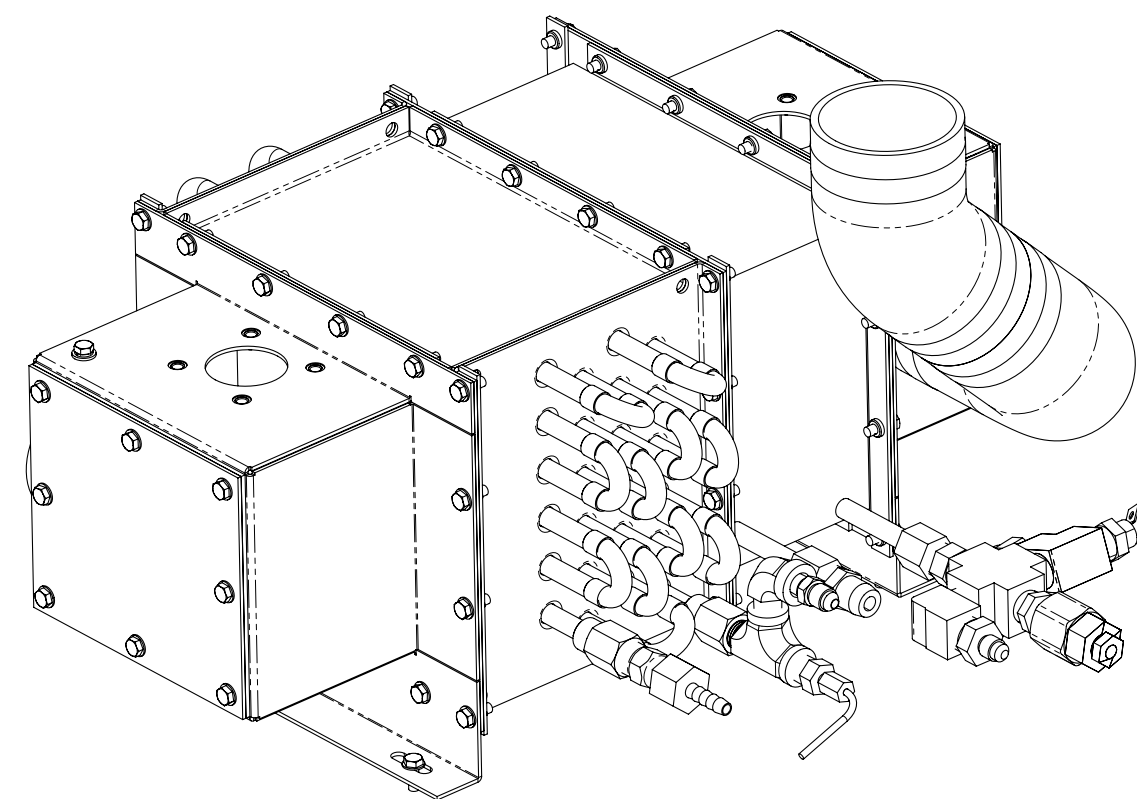
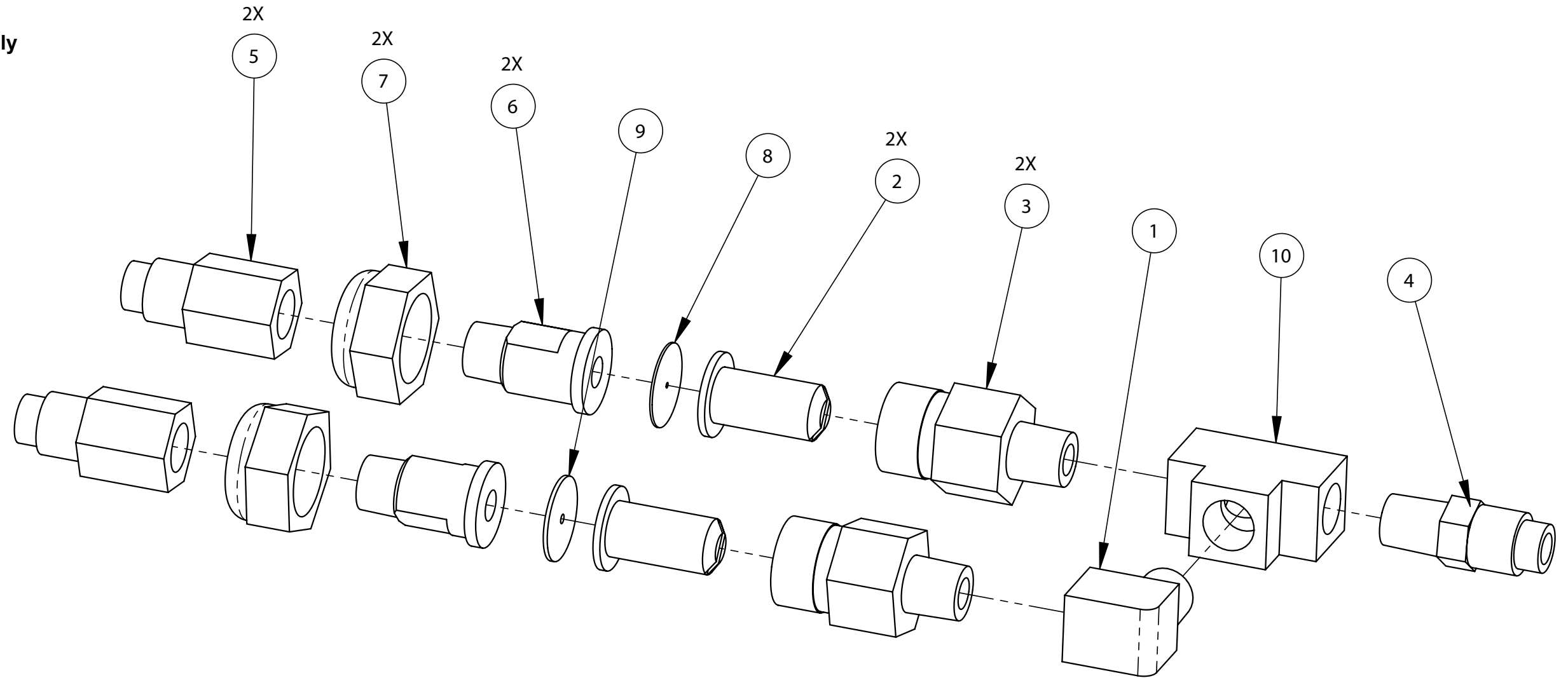


Figure 8-29. Orifice Assembly
610-021-729



Orifice Assembly Parts List

Item	Part Number	Description	Qty
1	000-052-084	Elbow, 1/8" NPT Street	1
2	000-049-052	Filter Cartridge, 1/4" Brass	2
3	000-052-153	Housing, Stabilizer Nozzle	2
4	000-052-530	Nipple, 1/4" SAE X 1/8" NPT	1
5	000-052-586	Nipple, 1/8" FPT X 1/4" SAE	2
6	000-052-582	Nipple, Tee Jet Style Collar X 1/8" NPT	2
7	000-094-028	Nut, Brass Jet Assembly	2
8	000-180-010	Orifice, 0.039" Plate	1
9	000-180-024	Orifice, 0.067" Plate	1
10	000-052-092	Tee, 1/8" FPT	1

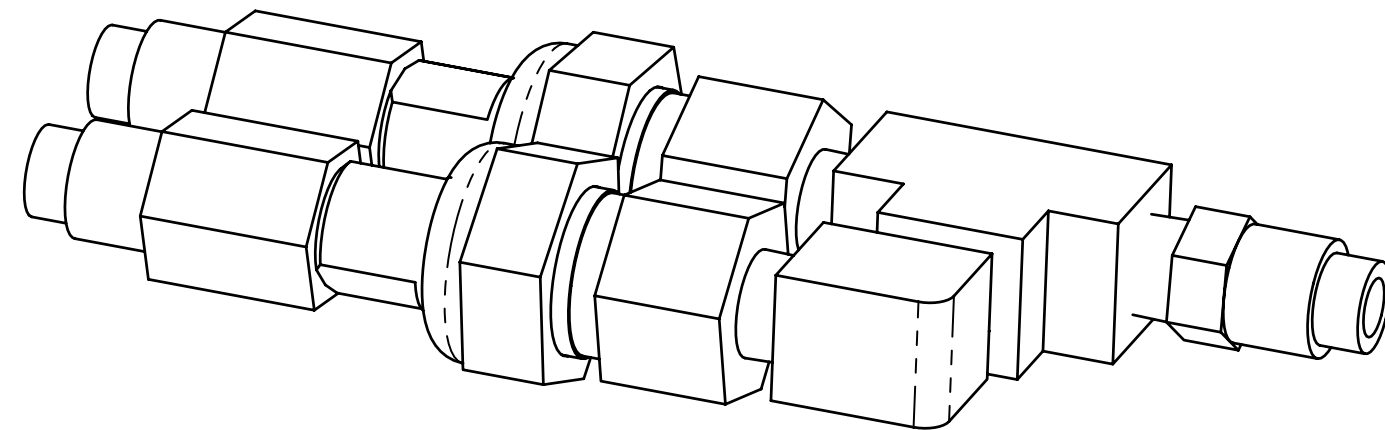
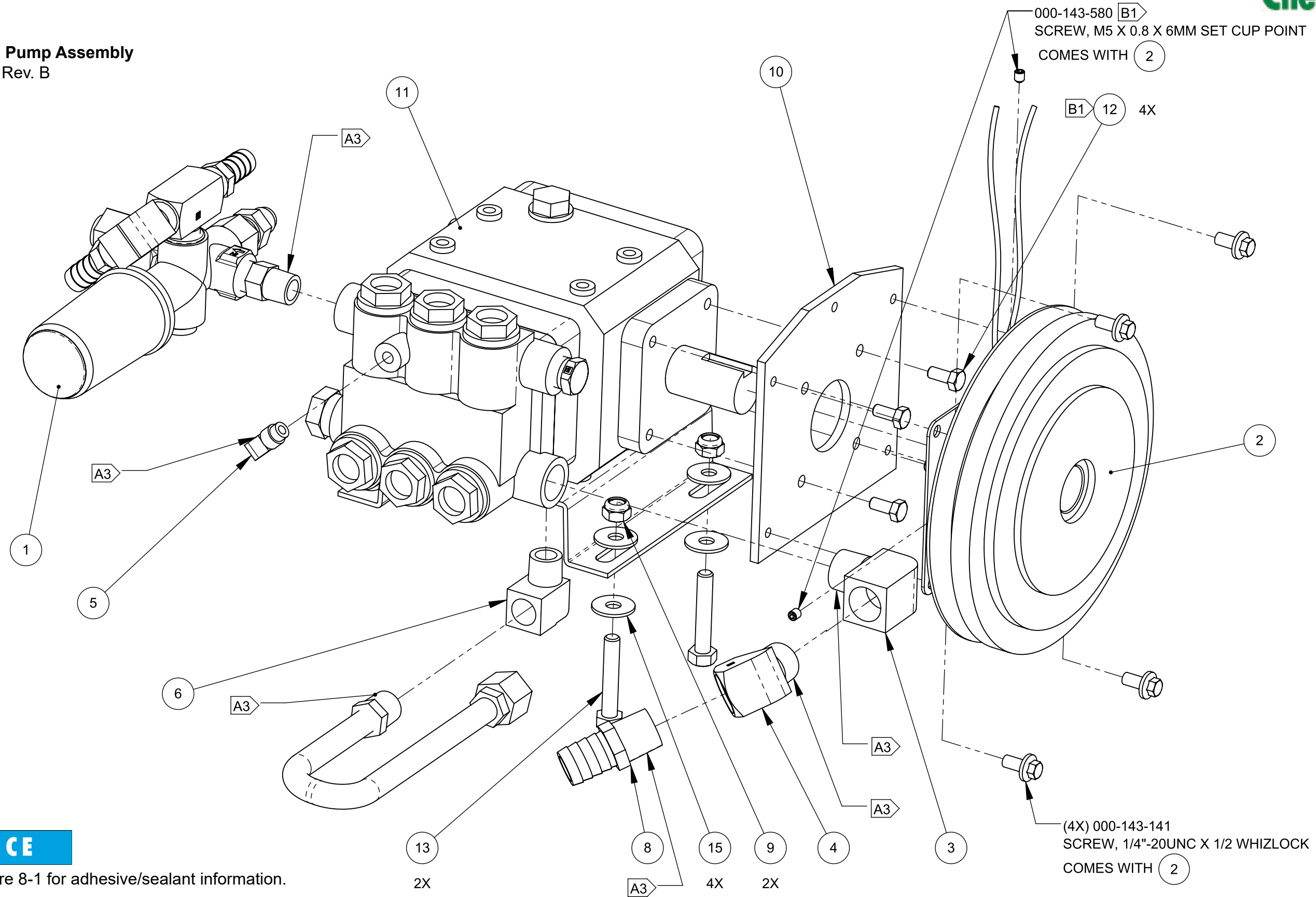


Figure 8-30. Pump Assembly
610-007-747 Rev. B



NOTICE

See Figure 8-1 for adhesive/sealant information.

Pump Assembly Parts List

Item	Part Number	Description	Qty	Item	Part Number	Description	Qty
1	610-009-747	Assembly, By-Pass Valve - CTS 403 Flex	1	9	000-094-038	Nut, 5/16"-18UNC Hex Nylock	2
2	000-036-008	Clutch, 7" O.D. 24MM Single Groove	1	10	000-105-148	Plate, Clutch Mount Pump	1
3	000-052-087	Elbow, 1/2" NPT Street	1	11	000-111-042	Pump	1
4	000-052-081	Elbow, 1/2" NPT Street X 45 Degree	1	12	000-143-221	Screw, M6-1 X 14MM Lg. Hex Head	4
5	000-052-531	Elbow, 1/8" NPT X 1/4" SAE	1	13	000-143-375	Screw, 5/16"-18UNC X 1.75" Lg. Hex Head Grd. 8 Z/P	2
6	000-052-086	Elbow, 3/8" NPT Street	1	14	000-143-012	Screw, 5/16"-18UNC X 3/4" Lg.	2
7	000-068-219	Hose, Drain	1	15	000-174-004	Washer, 5/16" Flat, USS	6
8	000-052-129	Insert, #812, 1/2NPT X 3/4 Hose	1	16	000-174-018	Washer, 5/16" Lock	2

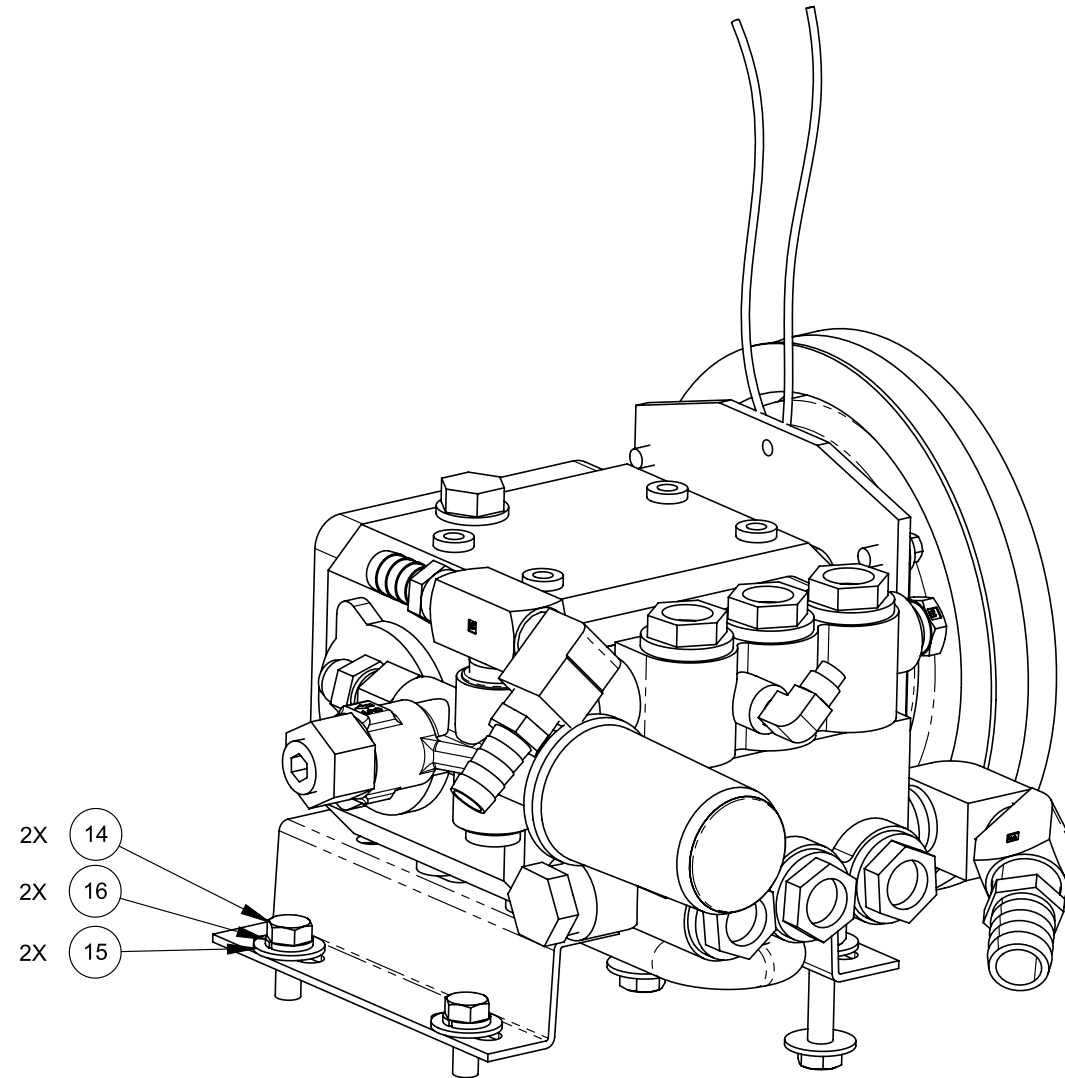
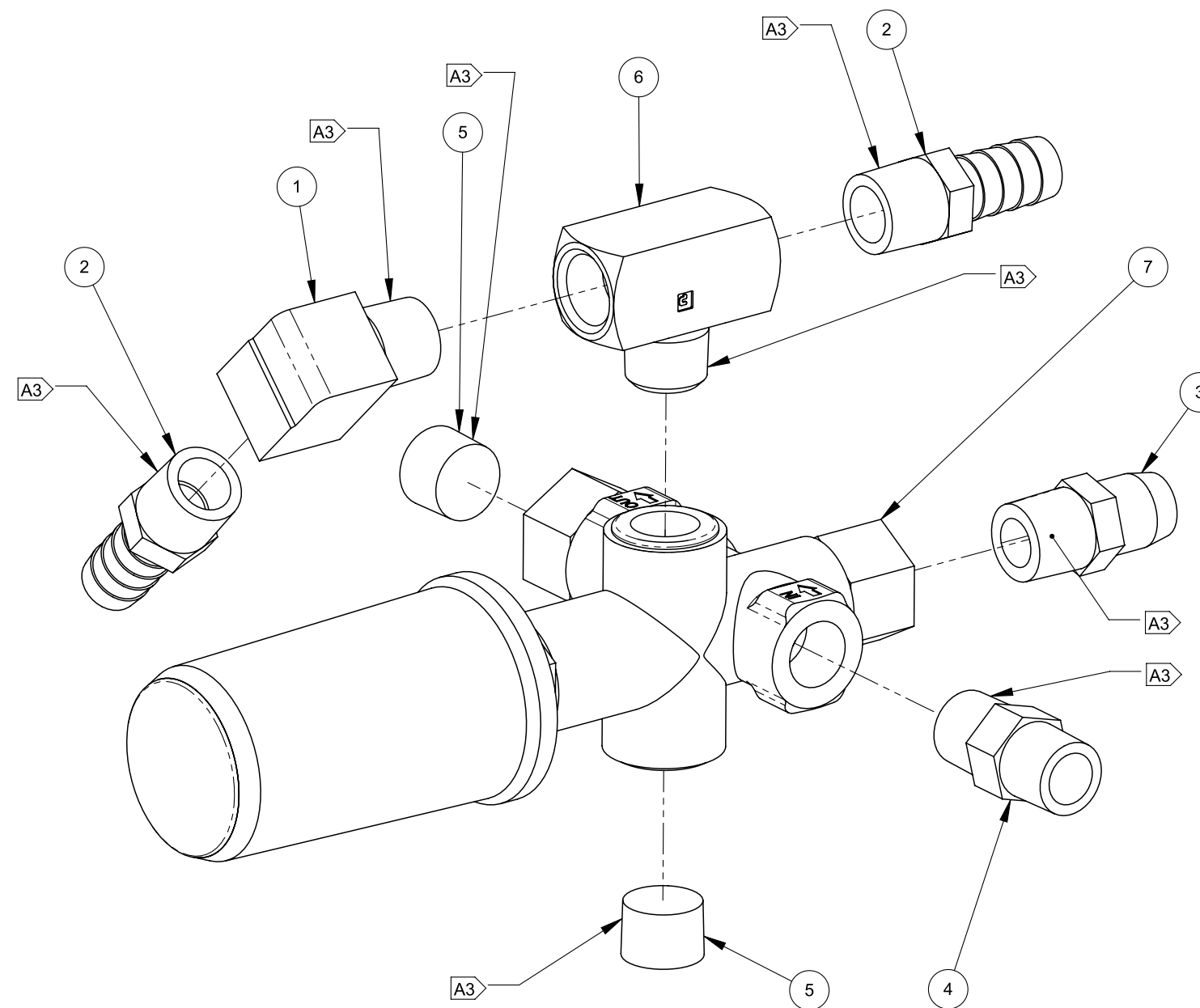
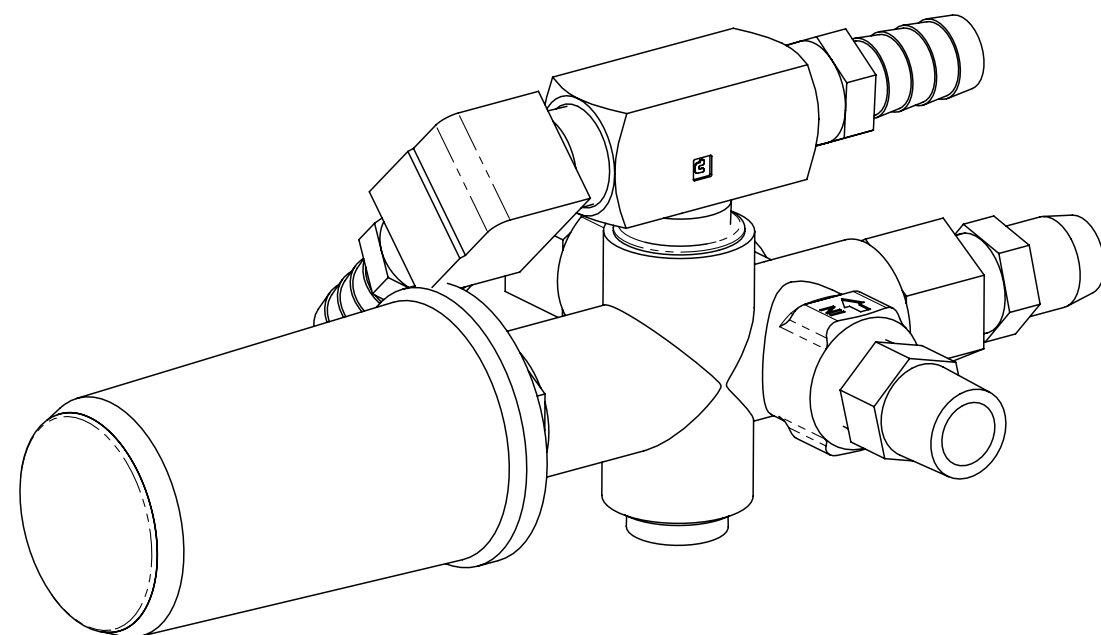


Figure 8-31. By-Pass Valve Assembly
610-009-747 Rev. B



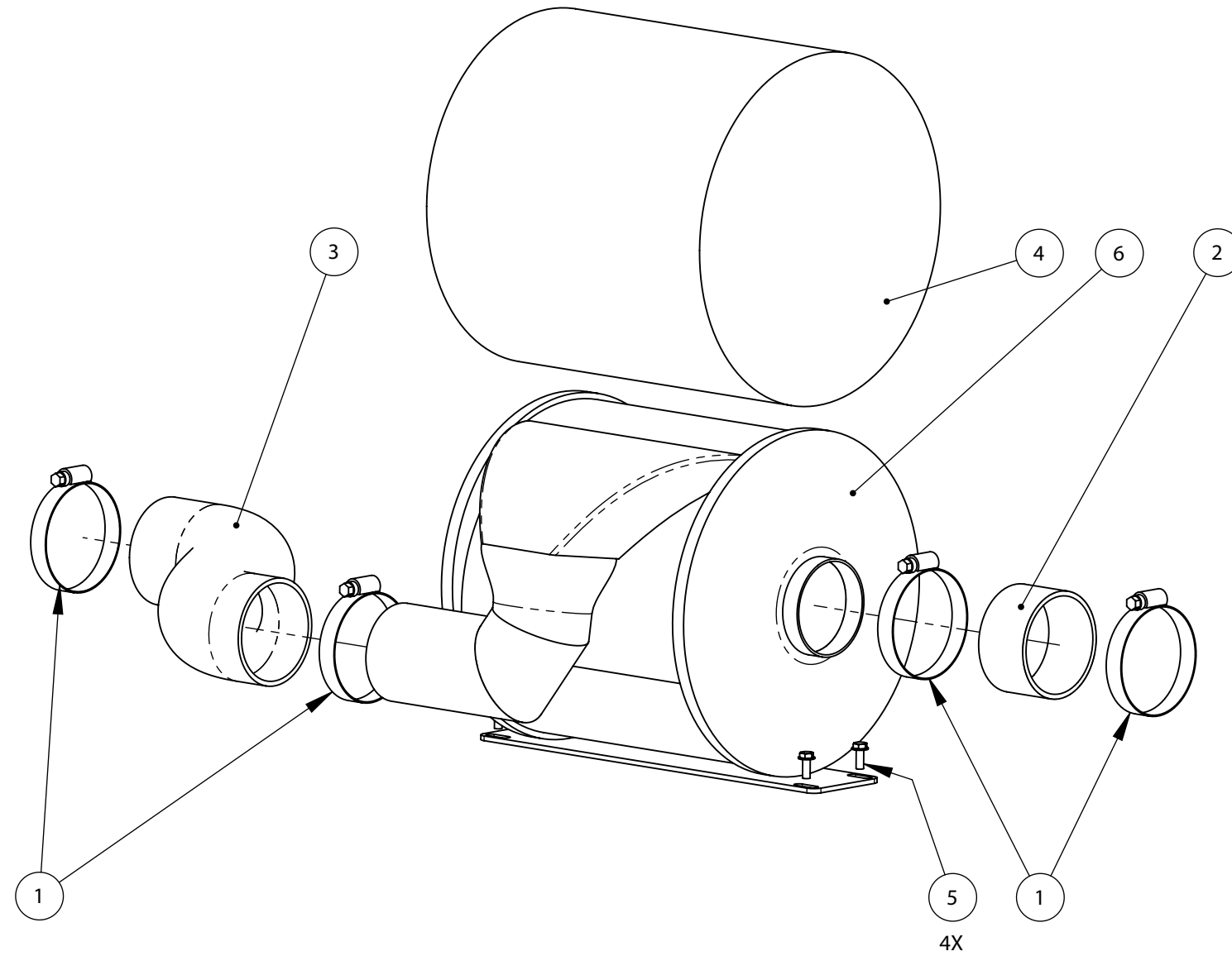
By-Pass Valve Assembly Parts List

Item	Part Number	Description	Qty
1	000-052-086	Elbow, 3/8" NPT Street	1
2	000-052-105	Insert, #68 (3/8" NPT X 1/2" Barb)	2
3	000-052-528	Nipple, 3/8" M JIC X 3/8" NPT	1
4	000-052-074	Nipple, 3/8" NPT Hex	1
5	000-106-008	Plug, 3/8" NPT Allen Head	2
6	000-052-447	Tee, 3/8" NPT Male Branch	1
7	000-169-351	Valve, Pressure Regulator-Modified	1

NOTICE

See Figure 8-1 for adhesive/sealant information.

Figure 8-32. Silencer Assembly
610-021-728 Rev. A



Silencer Assembly Parts List

Item	Part Number	Description	Qty
1	000-033-011	Clamp, Size #36 Hose	4
2	000-068-984	Hose, 2.5" Heat Flex NS X 1.5" Lg.	1
3	000-068-985	Hose, 2.5" Heat Flex NS X 12" Lg.	1
4	000-108-036	Protector, Silencer	1
5	000-143-583	Screw, #10-24UNC X 0.50" Lg. Hex Head Flange Z/P	4
6	000-093-022	Silencer, 2.5" Cowl	1

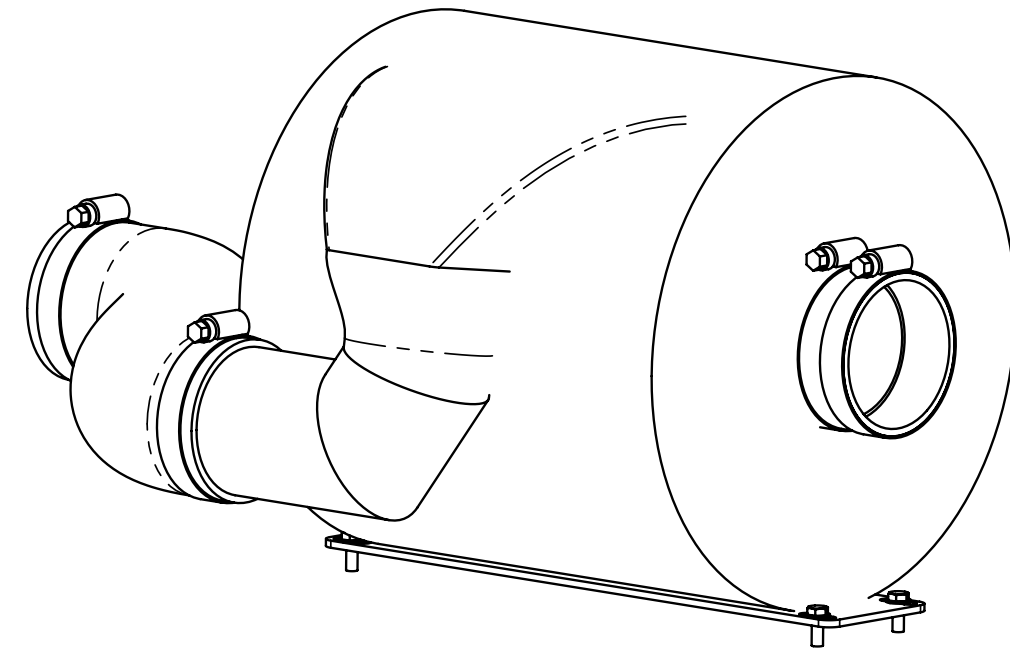
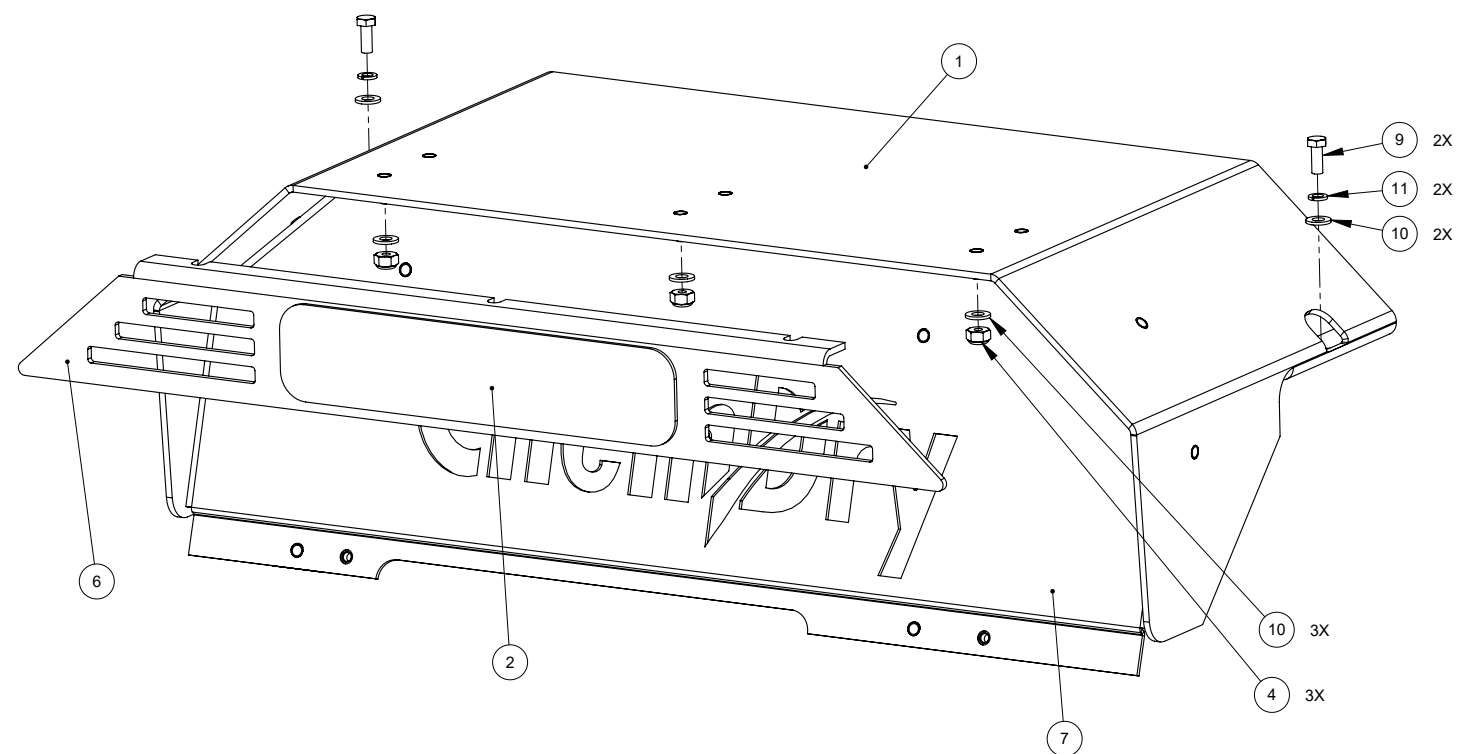
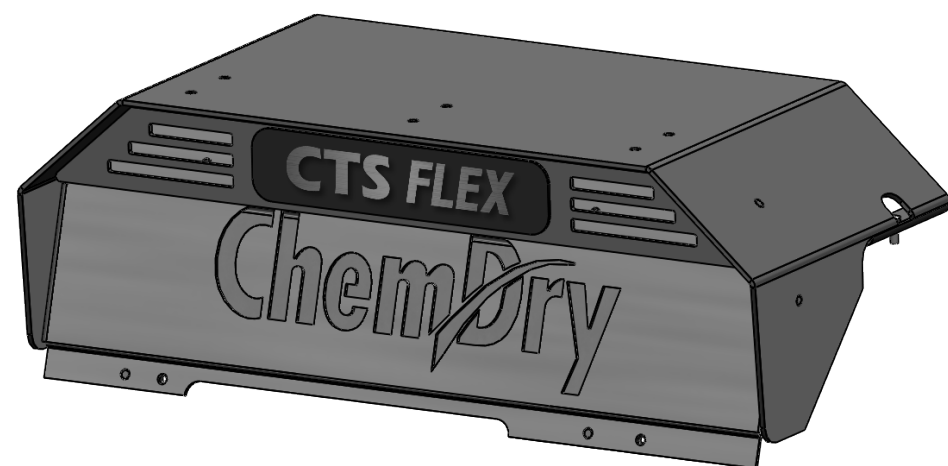


Figure 8-33. Top Cover - CTS 403 FLEX Assembly
610-022-749 Rev. A



Top Cover - CTS 403 Flex Assembly Parts List

Item	Part Number	Description	Qty
1	000-041-921	COVER, MACHINE TOP - COATED TITAN 325	1
2	000-081-559	LABEL, DOME - CTS FLEX	1
3	000-084-027	LAMP, 12V LED 12MM PANEL MOUNT - BLUE	2
4	000-094-034	NUT, #10-24UNC HEX NYLOCK	10
5	000-094-058	NUT, #10-32UNF HEX NYLOCK	4
6	000-100-388	PANEL, BROW END - COATED TITAN 325	1
7	000-100-398	PANEL, BROW FRONT - CTS 403	1
8	000-105-810	PLATE, LED DEFLECTOR	1
9	000-143-126	SCREW, #10-24UNC x 0.50" LG. HEX HEAD	2
10	000-174-001	WASHER, #10 FLAT	16
11	000-174-014	WASHER, #10 LOCK	2

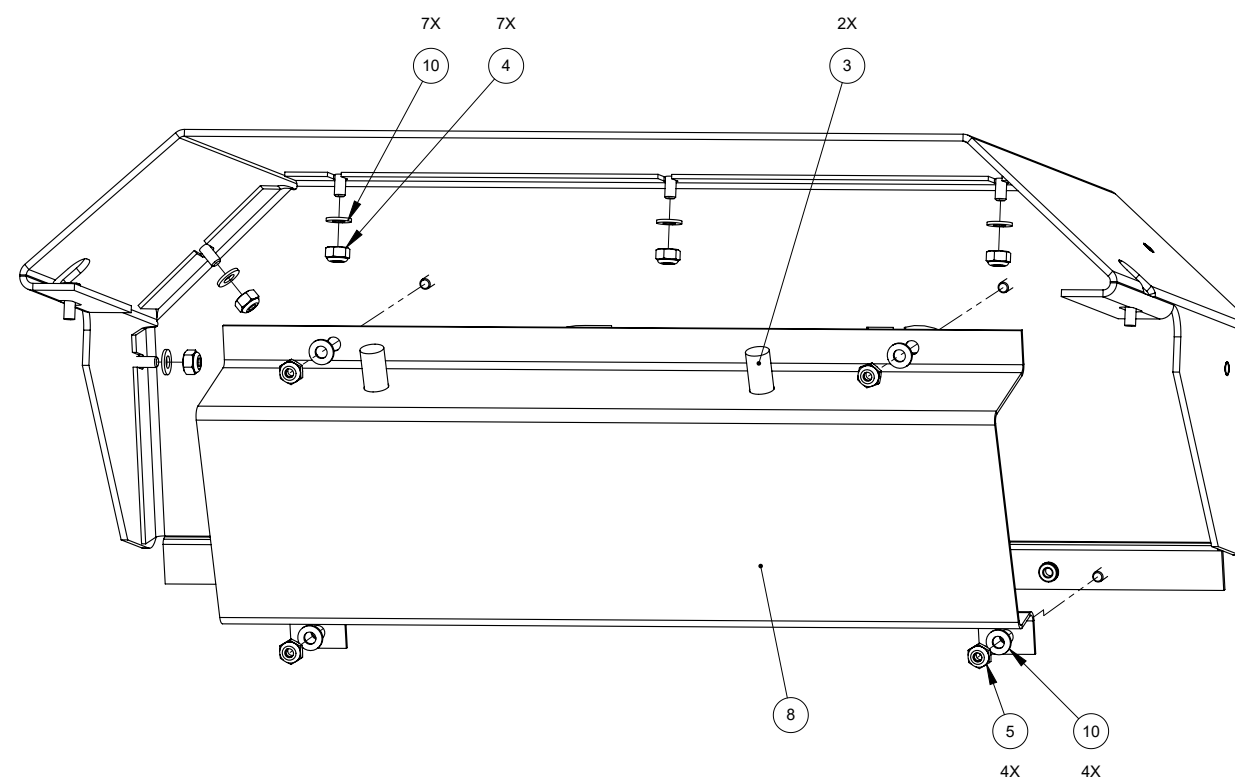
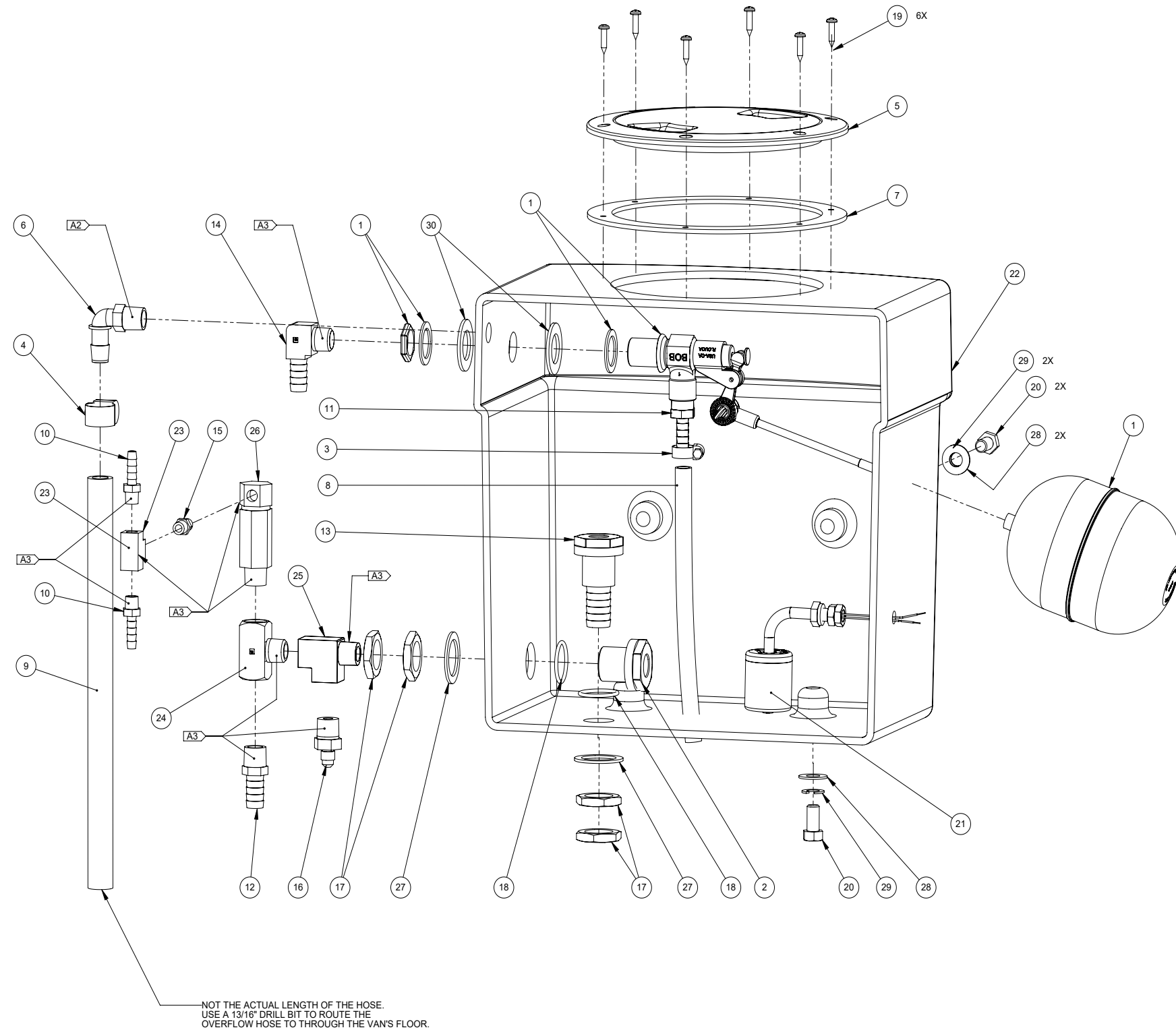


Figure 8-34. Water Box Assembly
610-010-749 Rev. A



Water Box Assembly Parts List

Item	Part Number	Description	Qty
1	000-169-235	ASSEMBLY, ROBERT FLOAT VALVE	1
2	000-052-660	BULKHEAD, 3/8" FPT x 3/8" FPT	1
3	000-033-003	CLAMP, SIZE #4 MINI HOSE	1
4	000-033-004	CLAMP, SIZE #6 MINI HOSE	1
5	000-041-005	COVER, 6" ACCESS	1
6	000-052-355	ELBOW, 3/8" NPT x 1/2" HOSE	1
7	000-057-256	GASKET - 6 IN. COVER LID	1
8	000-068-827	HOSE, 3/8" CLEAR w/ BRAID x 8" LG.	1
9	000-068-1126	HOSE, 1/2" I.D. RUBBER X 48" LG	1
10	000-052-097	INSERT, #24	2
11	000-052-104	INSERT, #66 (3/8" NPT x 3/8" BARB)	1
12	000-052-105	INSERT, #68 (3/8" NPT x 1/2" BARB)	1
13	000-052-661	INSERT, 3/4" BARB X STRAIGHT	1
14	000-052-956	INSERT, 3/8" NPT X 1/2" BARB X 90° BRASS	1
15	000-052-069	NIPPLE, 1/8" NPT HEX	1

Item	Part Number	Description	Qty
16	000-052-662	NIPPLE, 3/8" NPT x 1/4" M SAE	1
17	000-094-097	NUT, 1"-14UNS BRASS	4
18	000-097-041	O-RING, 1/2" BULK HEAD	2
19	000-143-739	SCREW, #8-15 X 3/4" LG. PH SHEET METAL SS	6
20	000-143-017-1	SCREW, 3/8"-16UNC x 0.75" LG. HEX HEAD	3
21	000-157-0801	SWITCH, w/PROTECTOR, POLYPRO BARREL - NC	1
22	000-159-190	TANK, POLY WATER BOX - 4 GALLON - MODIFIED	1
23	000-052-092	TEE, 1/8" FPT	1
24	000-052-447	TEE, 3/8" NPT MALE BRANCH	1
25	000-052-023	TEE, 3/8" NPT MALE STREET	1
26	000-169-011	VALVE, HI TEMP CONTROL 180°	1
27	000-174-063	WASHER, 1.5" O.D. x 1.073" I.D. x 0.075" THK.	2
28	000-174-032	WASHER, 3/8" FLAT	3
29	000-174-057	WASHER, 3/8" LOCK	3
30	000-174-028	WASHER, 7/8" I.D. x 1.50" O.D. x 0.090" THK.	2

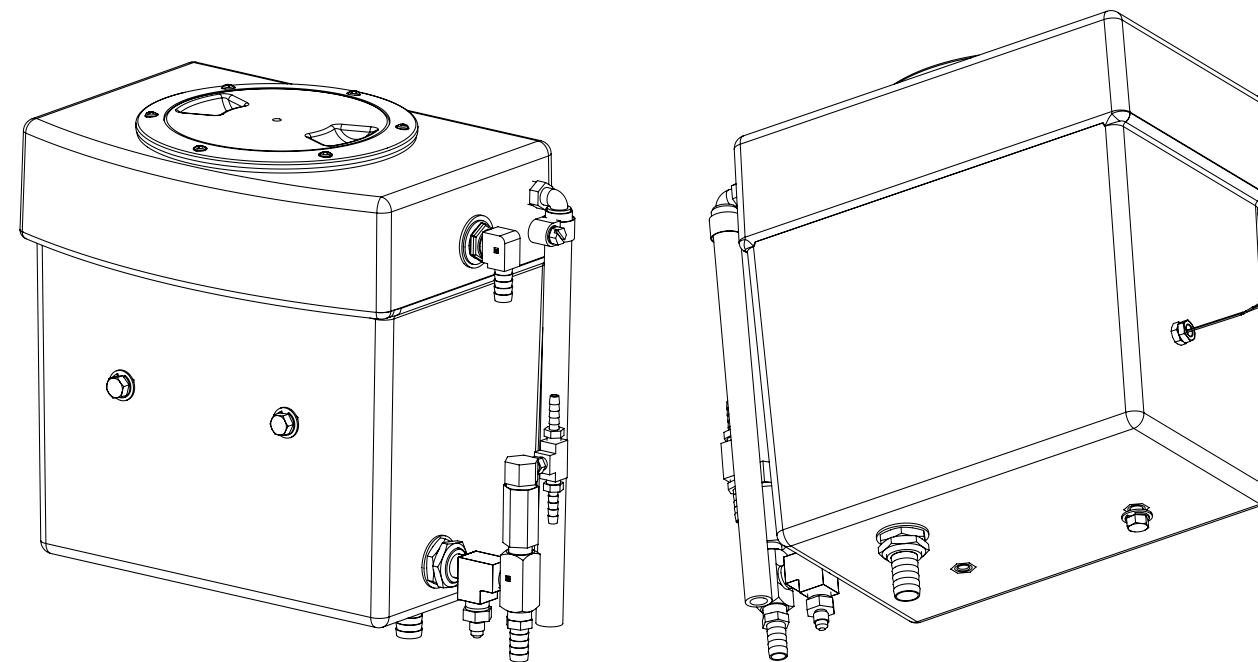
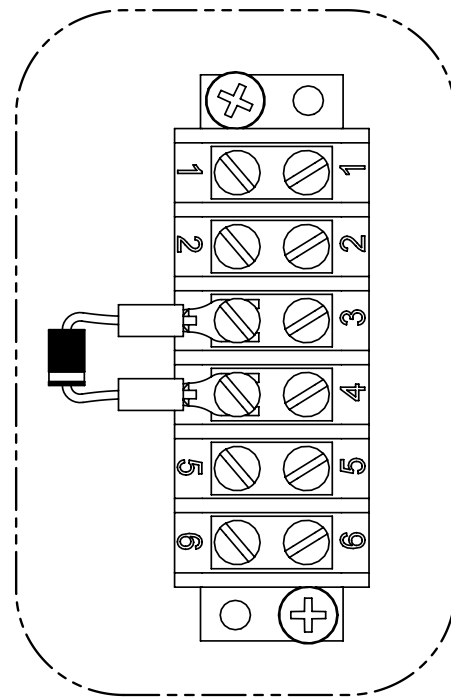




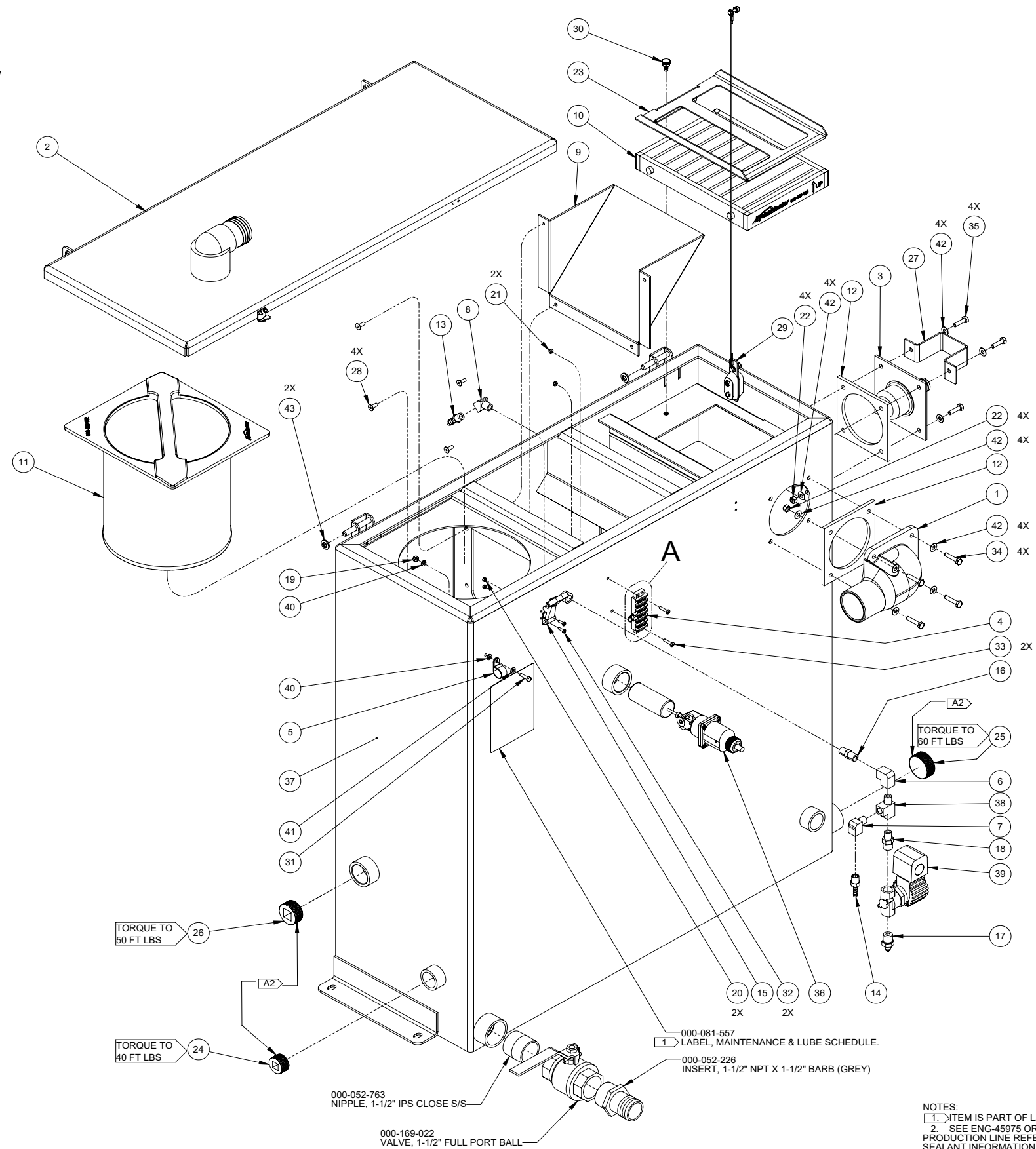
Figure 8-35. 70 Gallon Universal Recovery Tank (URT) Assembly
View 1 of 2
 610-003-749 Rev. A



DETAIL VIEW A

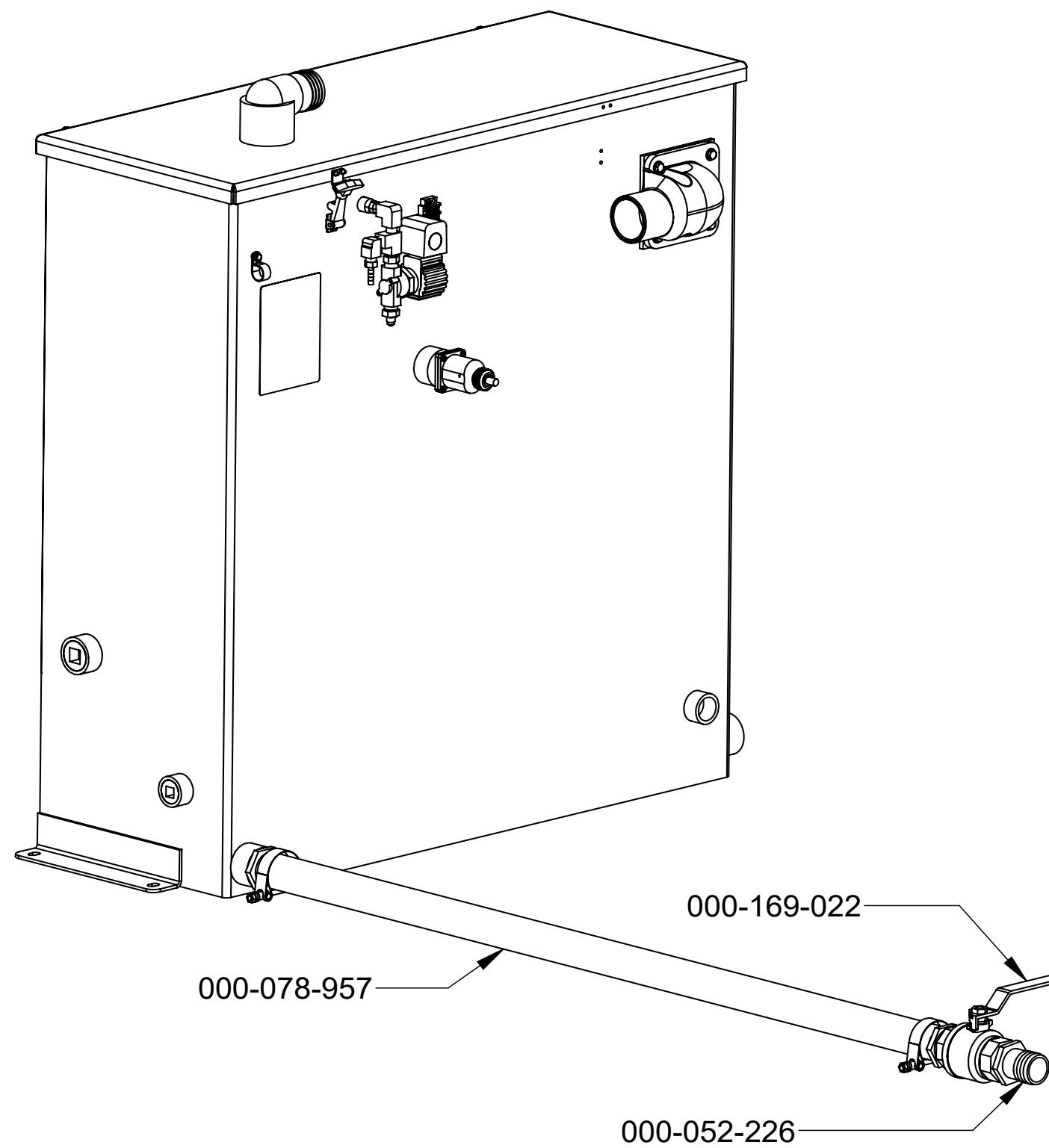
NOTICE

On installs with Dump Hook Up Kits, 000-052-763 has been replaced with 000-078-957. See assembly in the following page



NOTES:
 1. ITEM IS PART OF LABEL SET #000-081-555.
 2. SEE ENG-45975 OR ADHESIVE MATERIAL PRODUCTION LINE REFERENCE CARD FOR SEALANT INFORMATION.

Figure 8-36. 70 Gallon Universal Recovery Tank (URT) Assembly
Dump Hose Hook Up Install- View 2 of 2
610-003-749 Rev. A





70 Gallon Universal Recovery Tank (URT) Assembly Parts List

Item	Part Number	Description	Qty
1	000-001-134	ADAPTER, Ø2.5" TANK x 90° BLOWER HOSE - CASTING	1
2	610-029-726	ASSEMBLY, COVER, 70 GAL URT, SINGLE VAC. (COATED E-01)	1
3	610-026-724	ASSEMBLY, VACUUM RELIEF VALVE - URT	1
4	000-012-002	BLOCK, 6 POST TERMINAL	1
5	000-033-023	CLAMP, 3/4" NYLON HOSE	1
6	000-052-088	ELBOW, 1/4" FPT x FPT	1
7	000-052-085	ELBOW, 1/4" NPT STREET	1
8	000-052-082	ELBOW, 1/4" NPT STREET x 45°	1
9	000-049-154	FILTER, AIR DEFLECTOR, URT - FABRICATED	1
10	000-049-153	FILTER, FLAT - UNIVERSAL RECOVERY TANK	1
11	000-049-152	FILTER, RECOVERY TANK BASKET	1
12	000-057-206	GASKET, ADAPTER - URT	2
13	000-052-102	INSERT, #46 (1/4" NPT x 3/8" BARB)	1
14	000-052-100	INSERT, #44	1
15	000-086-008	LATCH, BUNGEE	1
16	000-052-071	NIPPLE, 1/4" NPT HEX	1
17	000-052-662	NIPPLE, 3/8" NPT x 1/4" M SAE	1
18	000-052-073	NIPPLE, 3/8" NPT x 1/4" NPT HEX	1
19	000-094-034	NUT, #10-24UNC HEX NYLOCK	1
20	000-094-063	NUT, #6-32UNC HEX NYLOCK	2
21	000-094-059	NUT, #8-32UNC HEX NYLOCK	2
22	000-094-009	NUT, 1/4"-20UNC NYLOCK	8
23	000-105-785	PLATE, BLOWER FLAT FILTER - ZR	1
24	000-106-049	PLUG, 1" NPT BRONZE	1
25	000-106-019	PLUG, 1-1/2" NPT BRONZE	1
26	000-106-046	PLUG, 1-1/4" NPT BRONZE	1
27	000-108-179	PROTECTOR, VACUUM RELIEF - COATED	1
28	000-140-023	RIVET, AB8-6A ALUMINUM POP	4
29	000-079-226	SACRIFICIAL ANODE, MAGNISIIUM	1
30	000-143-787	SCREW THUMB 1/4-20X3/8	1
31	000-143-132	SCREW, #10-24UNC x 0.75" LG. HEX HEAD	1

Item	Part Number	Description	Qty
32	000-143-539	SCREW, #6-32UNC x 0.50" LG. BUTTON HEAD	2
33	000-143-051	SCREW, #8-32UNC x 0.75" LG. BINDER HEAD	2
34	000-143-010	SCREW, 1/4"-20UNC X 1.25" LG. HEX HEAD S/S	4
35	000-143-002	SCREW, 1/4"-20UNC x 1.00" LG. HEX HEAD	4
36	000-157-091	SWITCH, FLOAT LEVER	1
37	000-159-128	TANK, 70 GALLON URT - COATED E01	1
38	000-052-090	TEE, 1/4" NPT BRANCH M-F-F	1
39	000-169-082	VALVE, 12 VOLT SOLENOID 1200 PSI	1
40	000-174-036	WASHER, #10 FLAT RUBBER BACKED	2
41	000-174-001	WASHER, #10 FLAT	1
42	000-174-003	WASHER, 1/4" FLAT S/S	16
43	000-174-029	WASHER, 3/8" FLAT RUBBER BACKED	2

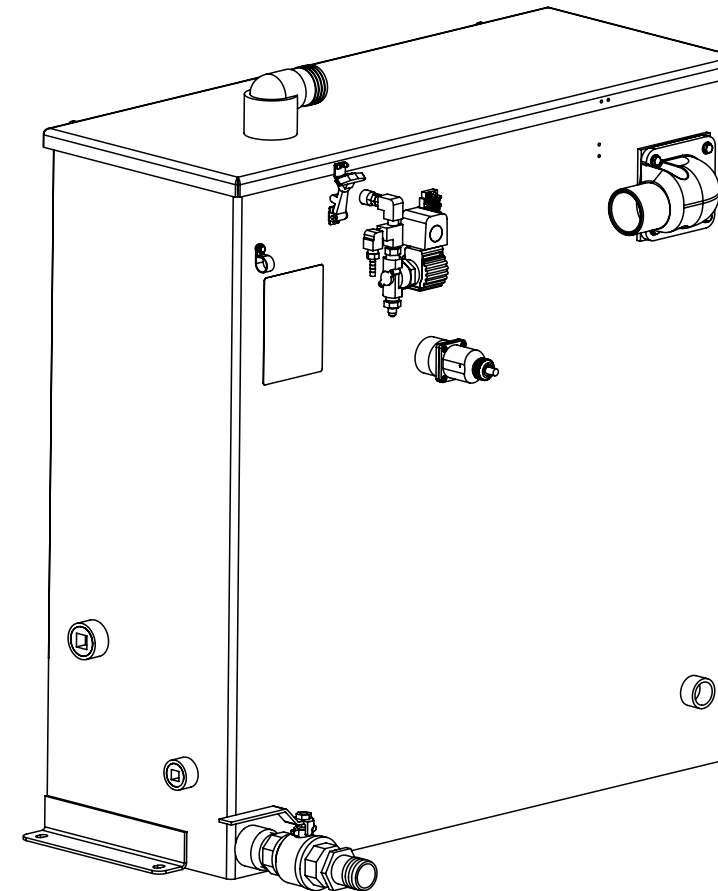
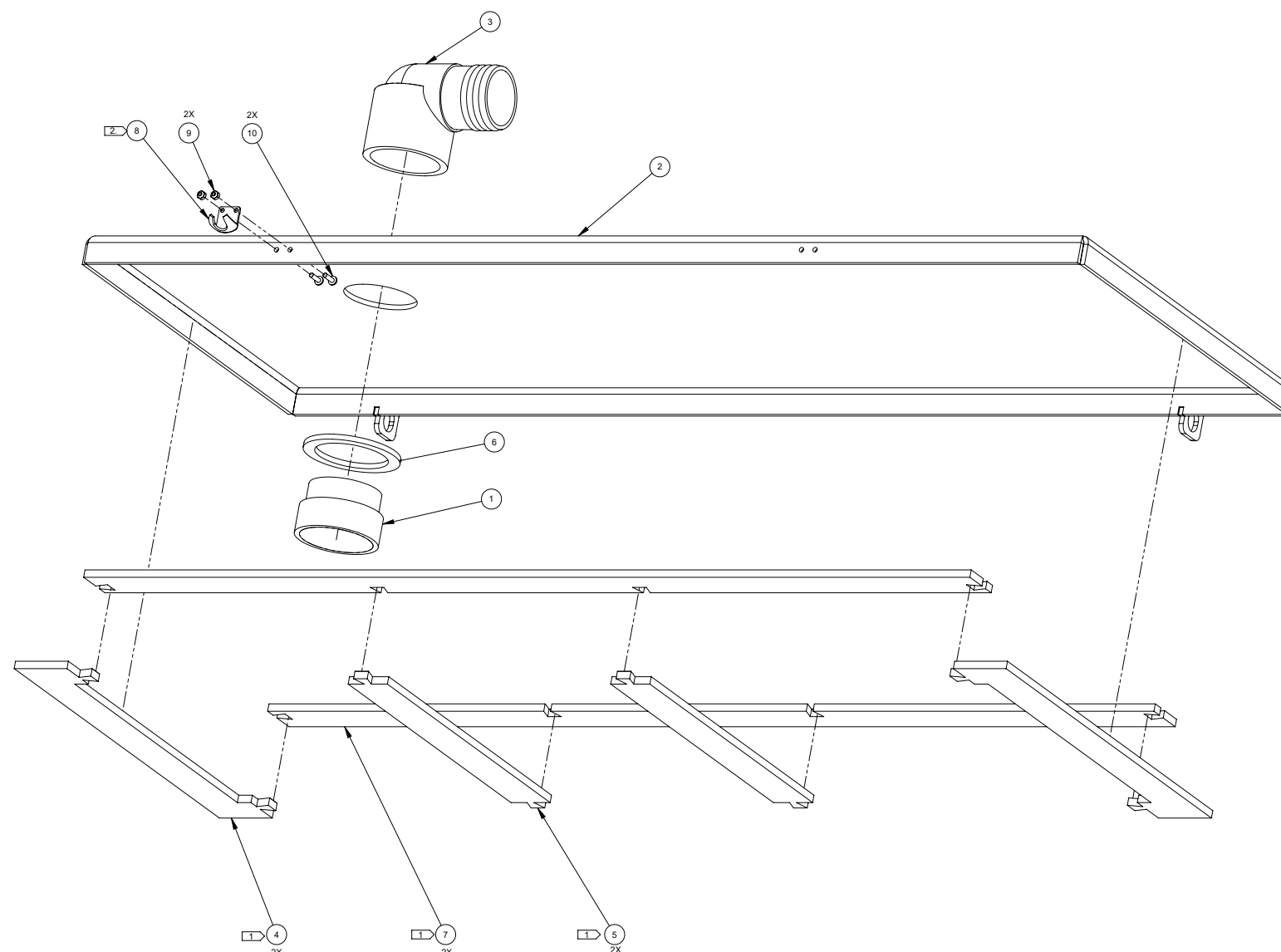
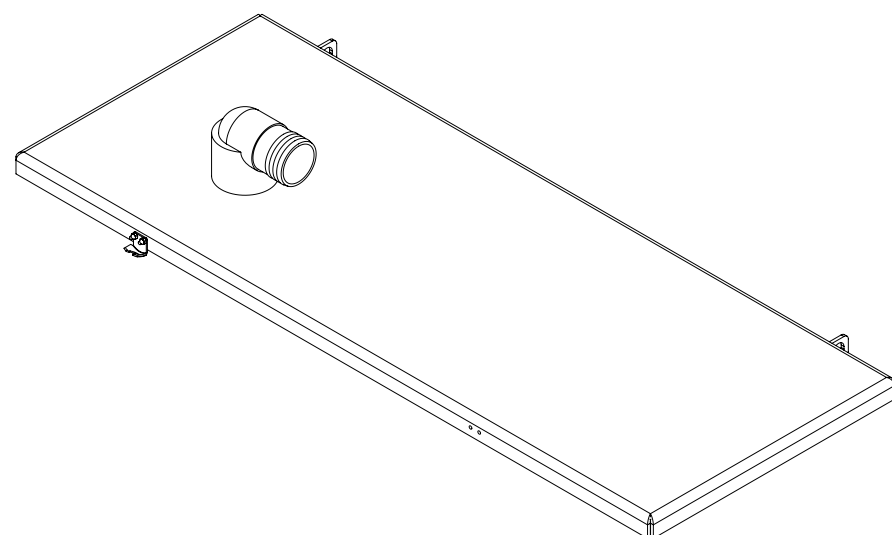


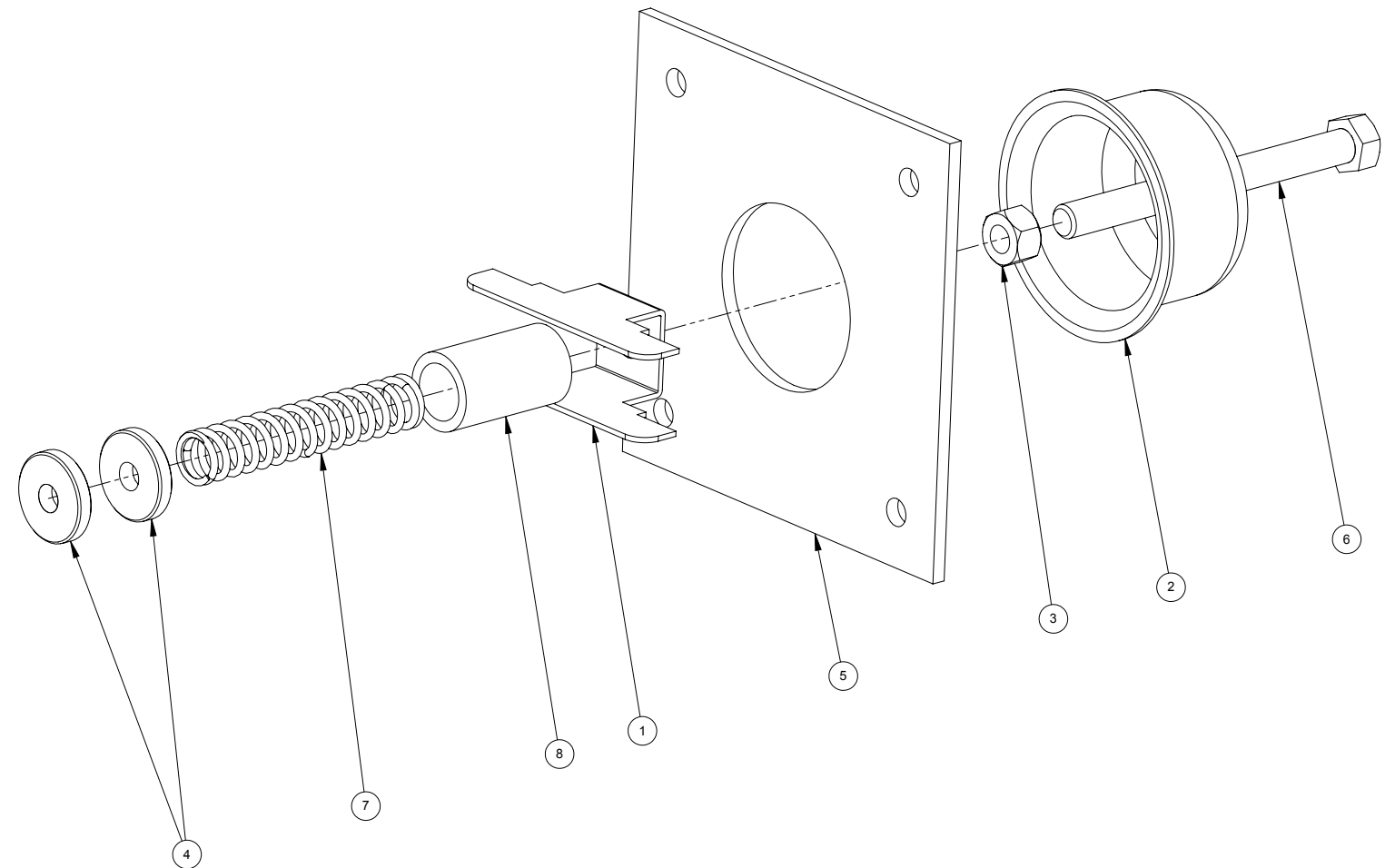
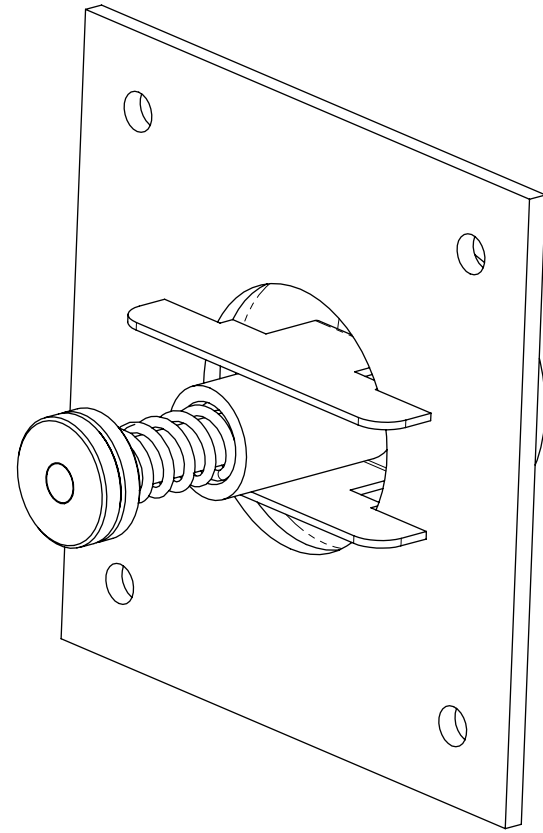
Figure 8-37. Cover, 70 Gal URT, Single Vac. Assembly
610-029-726 Rev. B



Cover, 70 Gal URT, Single Vac. Assembly Parts List

Item	Part Number	Description	Qty
1	000-052-219	ADAPTER, 2" NPT x 2" F SLIP	1
2	000-041-443	COVER, 70 URT 1 PORT - COATED E-01	1
3	000-052-222	ELBOW, 2" BARB x 2" FPT	1
4	000-057-202	GASKET, END - REC. TANK COVER	2
5	000-057-203	GASKET, MIDDLE - REC. TANK COVER	2
6	000-057-015	GASKET, 1-1/2" BULKHEAD FITTING	1
7	000-057-204	GASKET, SIDE - RECOVERY TANK	2
8	---	LATCH, BUNGEE - STRIKE (PART OF 000-086-008)	1
9	000-094-063	NUT, #6-32UNC HEX NYLOCK	2
10	000-143-539	SCREW, #6-32UNC x 0.50" LG. BUTTON HEAD	2

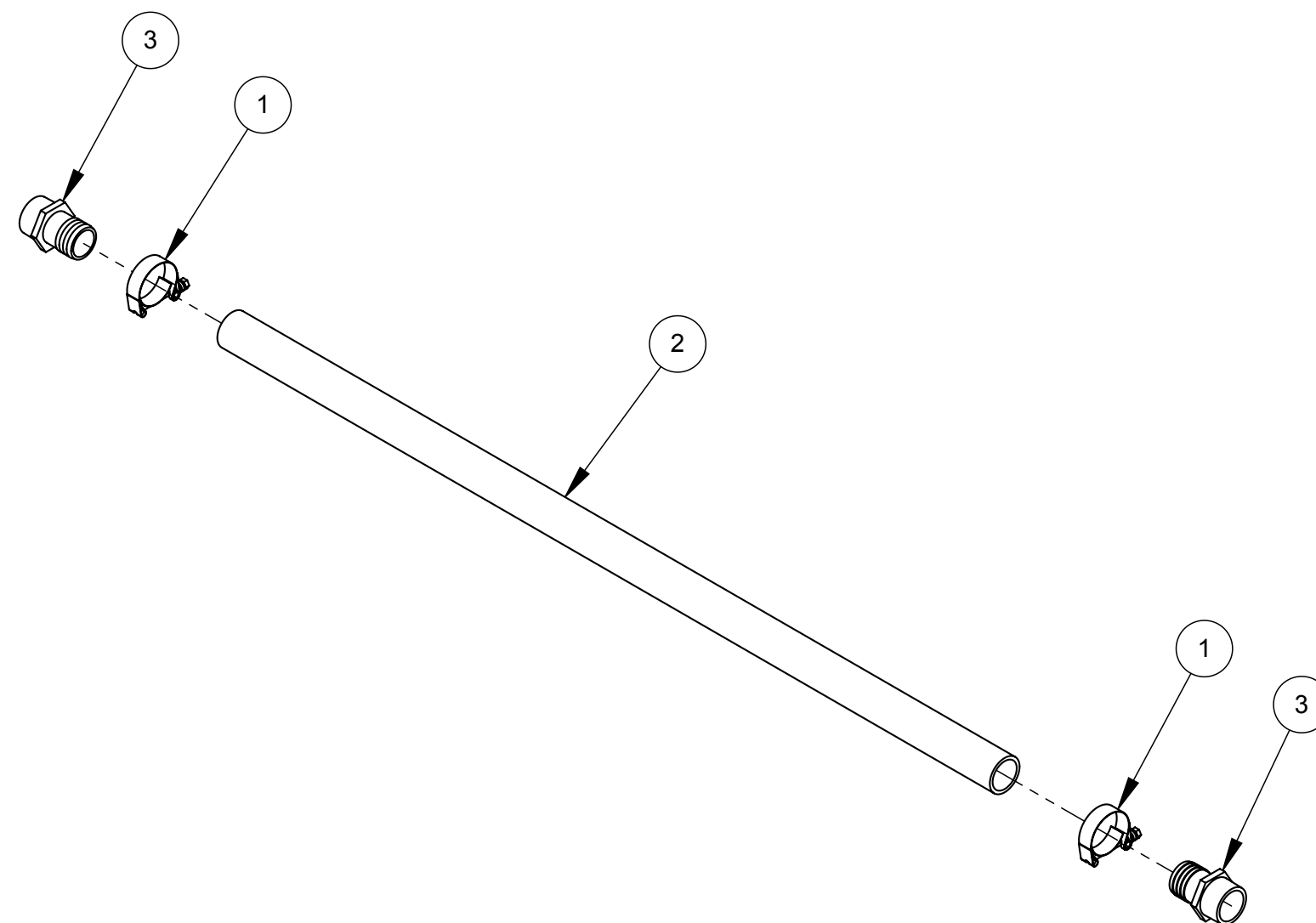
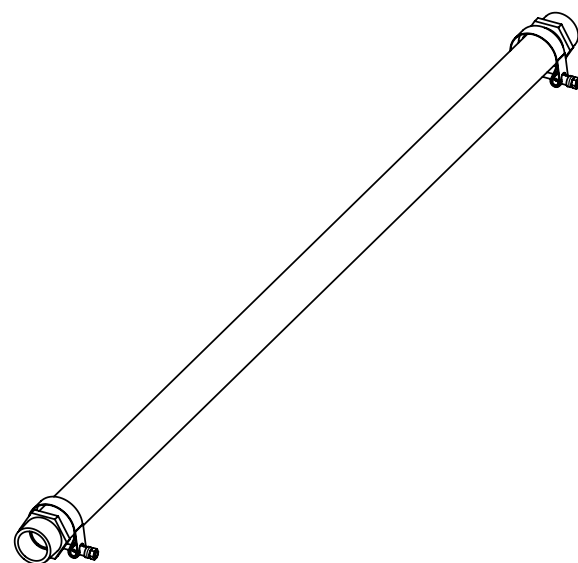
Figure 8-38. Vacuum Relief Valve - URT Assembly
610-029-724 Rev. B



Vacuum Relieft Valve - URT Assembly Parts List

Item	Part Number	Description	Qty
1	000-015-182	BRACKET, VACUUM RELIEF VALVE - FABRICATED	1
2	000-027-032	CAP, SPUN VACCUM RELIEF VALVE	1
3	000-094-101	NUT, 3/8"-16UNC HEX JAM	1
4	000-094-077	NUT, 3/8"-16UNC x 1.00" O.D. KNURLED	2
5	000-105-332	PLATE, VACUUM RELIEF VALVE MOUNTING - CTD	1
6	000-143-198	SCREW, 3/8"-16UNC x 4" LG. HEX HEAD	1
7	000-155-026	SPRING, VACUUM RELIEF VALVE	1
8	000-125-111	TUBE, VACUUM RELIEF SPRING GUIDE	1

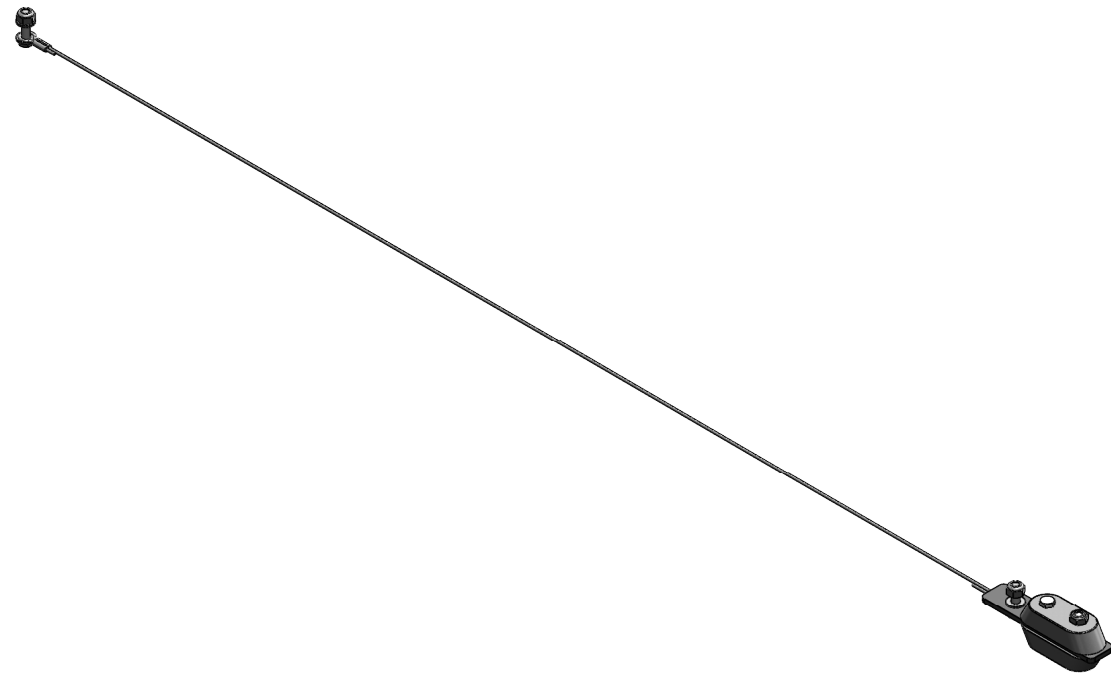
Figure 8-39. Dump Hose Hook Up Kit
000-078-957 Rev. A



Dump Hose Hook Up Kit Parts List

Item	Part Number	Description	Qty
1	000-033-063	CLAMP, 2" T-BOLT	2
2	000-068-882	HOSE, 1.5" I.D. RED STRIPE X 48" LG.	1
3	000-052-226	INSERT, 1-1/2" NPT x 1-1/2" BARB (GREY)	2

Figure 8-40. Sacrificial Anode Assembly
610-029-724 Rev. B



Sacrificial Anode Assembly Parts List

Item	Part Number	Description	Qty
1	000-015-1413	BRACKET, SACRIFICIAL ANODE - FABRICATED	1
2	000-025-098	CABLE, 1/16 S-STEEL - 31"	1
3	000-033-149	CLAMP, WIRE SLEEVE 1/16Ø S-STEEL	2
4	000-094-034	NUT, #10-24UNC HEX NYLOCK	2
5	000-094-150	NUT, 10-24 S/S NYLOK HALF	2
6	000-108-025	PROTECTOR, MAGNESIUM ANODE - UNMODIFIED	2
7	000-143-132	SCREW, #10-24UNC x 0.75" LG. HEX HEAD	2
8	000-143-171	SCREW, #10-24UNC x 1.25" LG. HEX HEAD	2
9	000-174-015	WASHER, #10 EXTERNAL STAR	1
10	000-174-001	WASHER, #10 FLAT	4

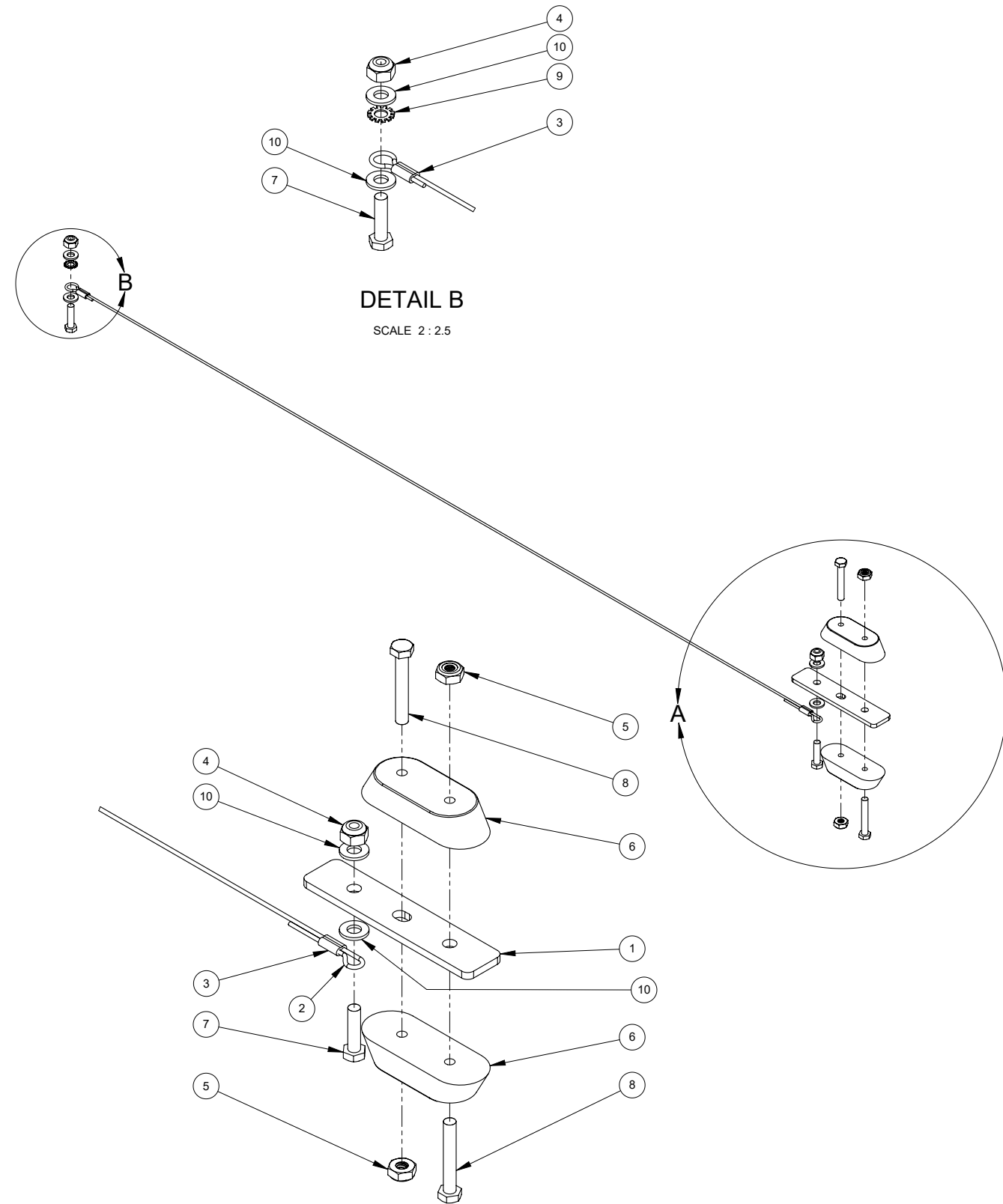
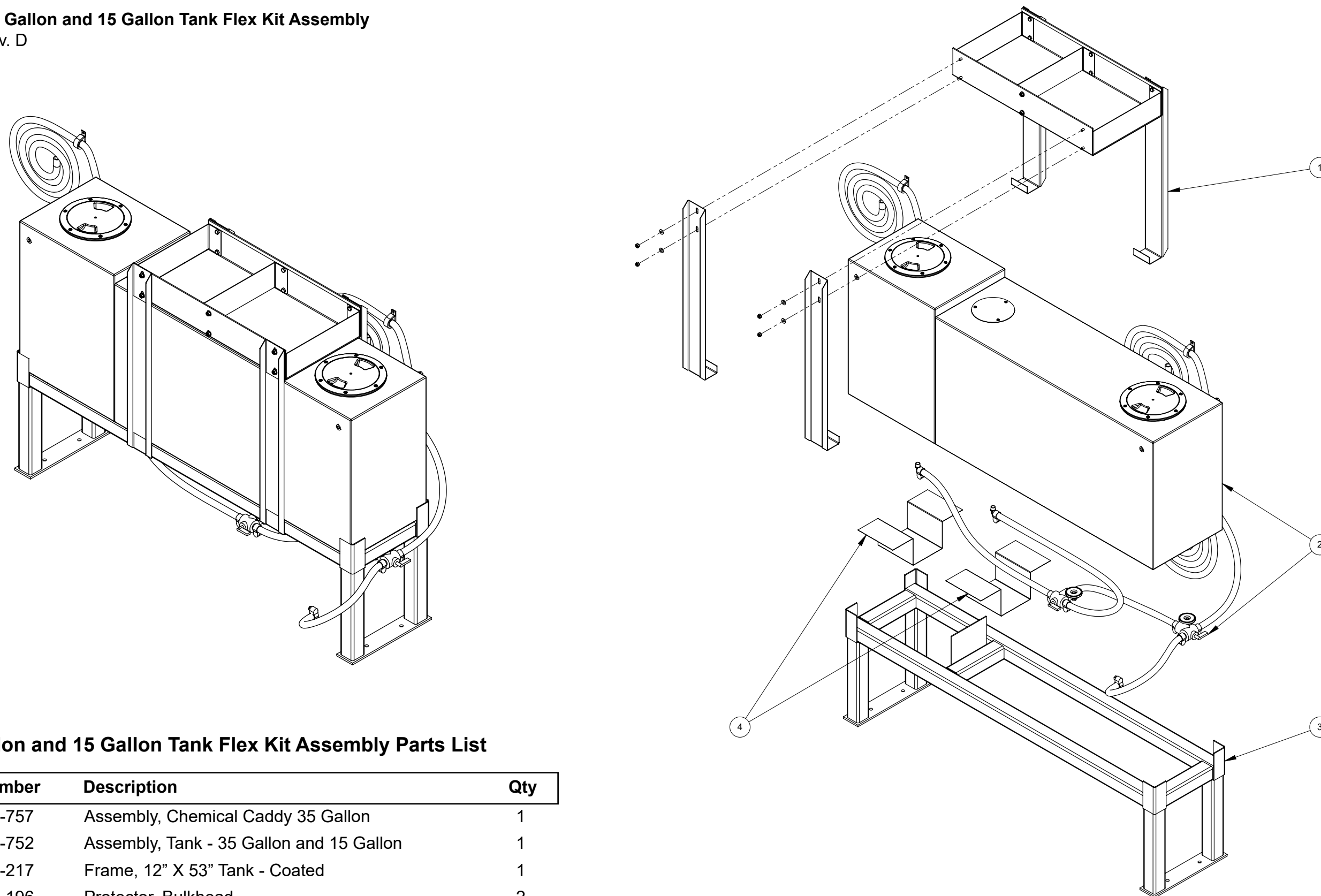


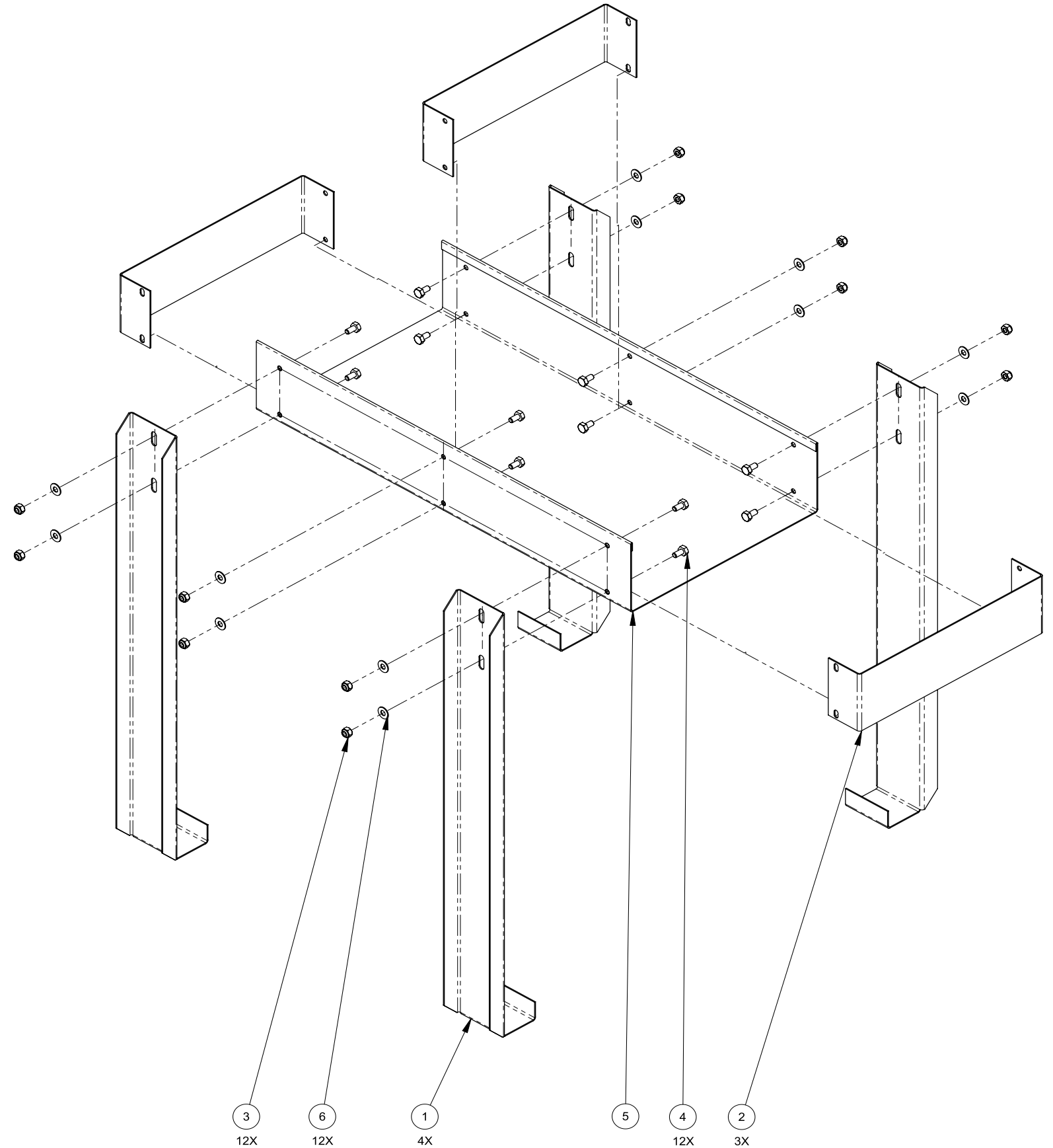
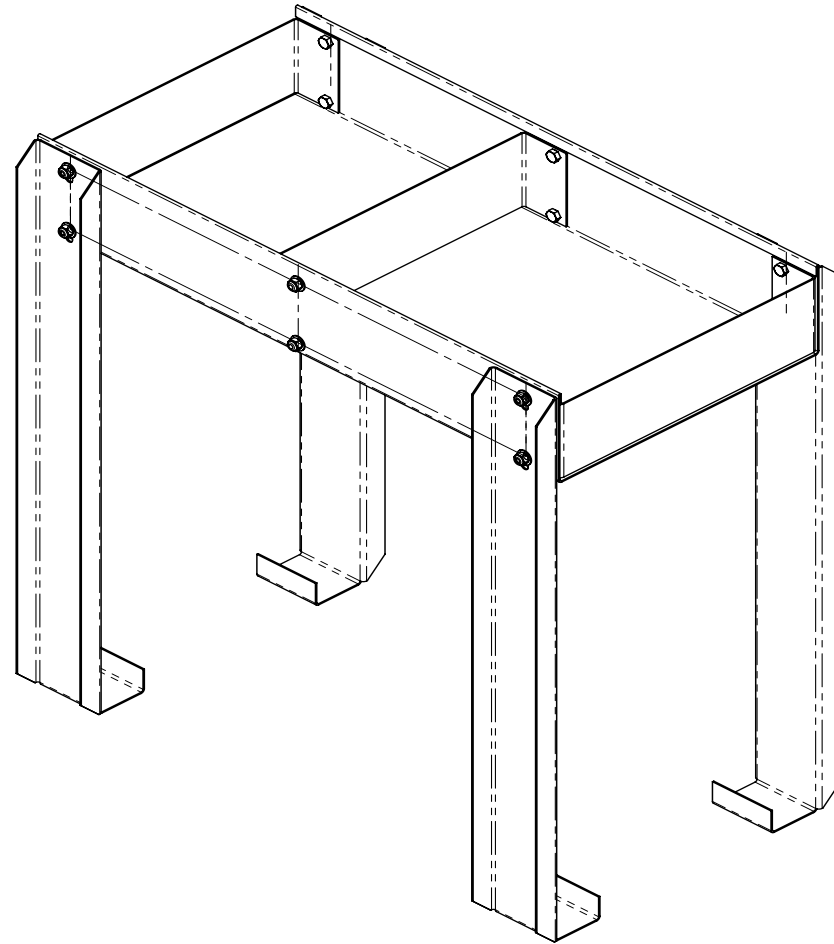
Figure 8-41. 35 Gallon and 15 Gallon Tank Flex Kit Assembly
000-163-753 Rev. D



35 Gallon and 15 Gallon Tank Flex Kit Assembly Parts List

Item	Part Number	Description	Qty
1	000-163-757	Assembly, Chemical Caddy 35 Gallon	1
2	000-163-752	Assembly, Tank - 35 Gallon and 15 Gallon	1
3	000-055-217	Frame, 12" X 53" Tank - Coated	1
4	000-108-196	Protector, Bulkhead	2

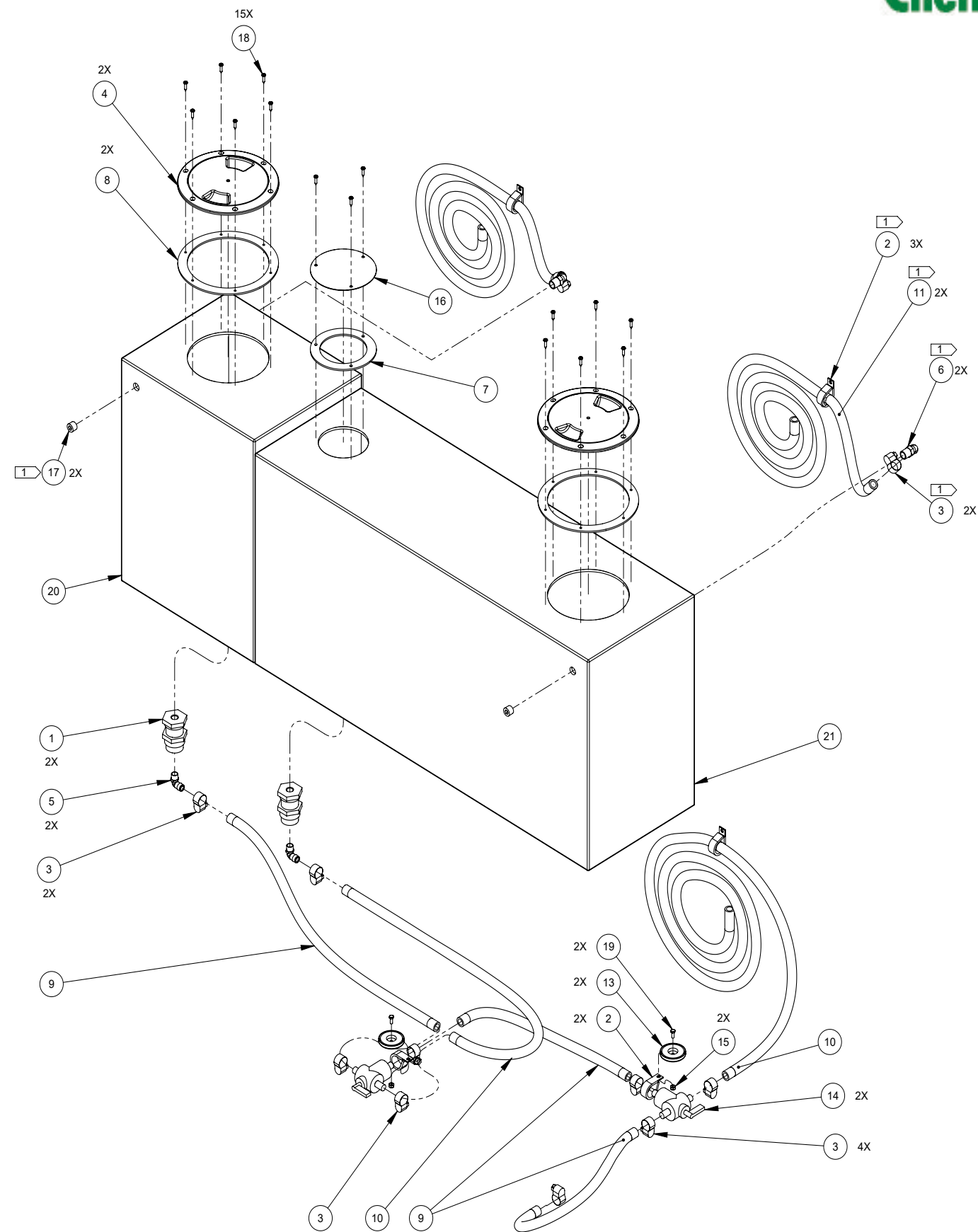
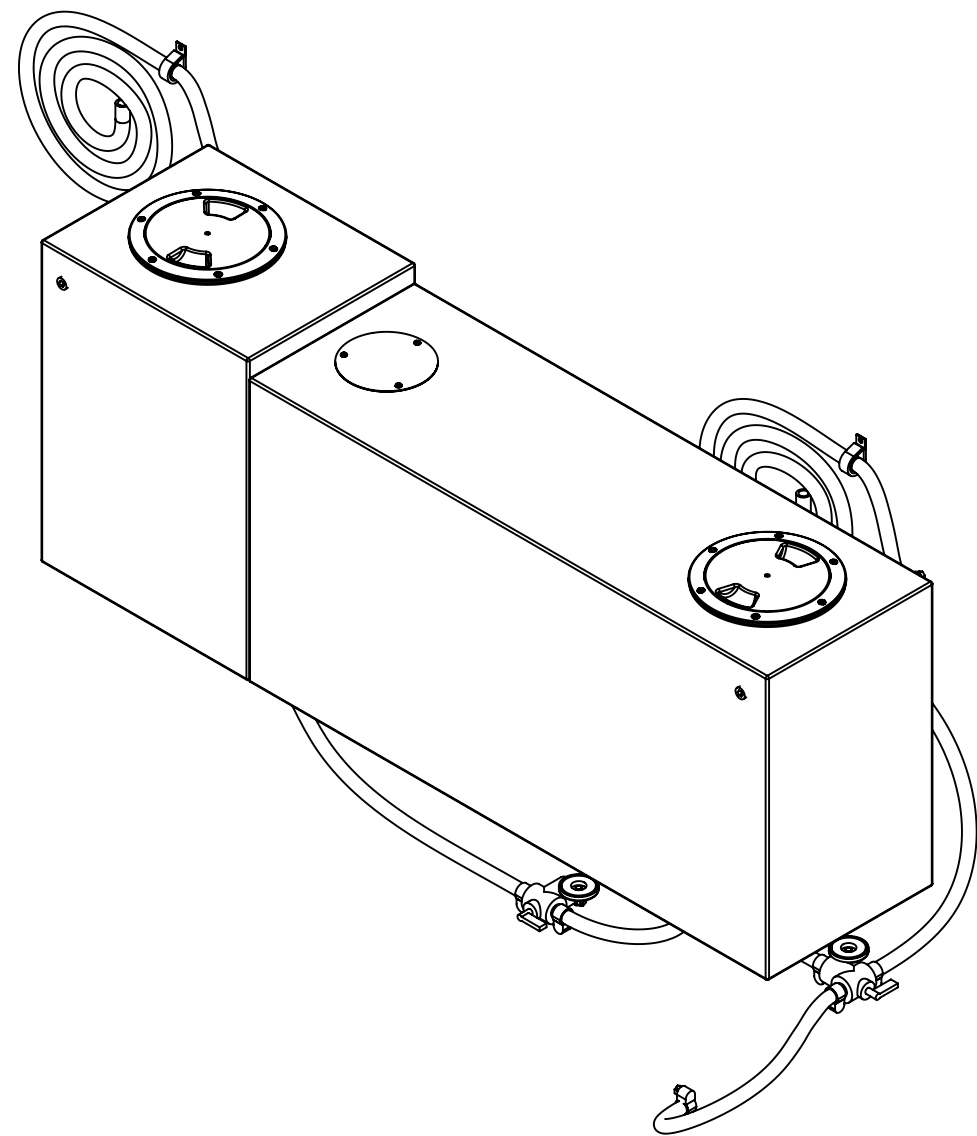
Figure 8-42. 35 Gallon Tank Flex Chemical Caddy Assembly
000-163-757 Rev. B



35 Gallon Tank Flex Chemical Caddy Assembly Parts List

Item	Part Number	Description	Qty
1	000-015-1265	Bracket, Tank Stiffener	4
2	000-015-1264	Bracket, Tank Tray Rib	3
3	000-094-071	Nut, 1/4"-20UNC Nylock Half	12
4	000-143-333	Screw, 1/4"-20UNC X 0.50" Lg. Hex Head	12
5	000-166-179	Tray, Tank - 26"	1
6	000-174-003	Washer, 1/4" Flat	12

Figure 8-43. 35 Gallon and 15 Gallon Tank Flex Assembly
000-163-752 Rev. G





35 Gallon and 15 Gallon Tank Flex Assembly Parts List

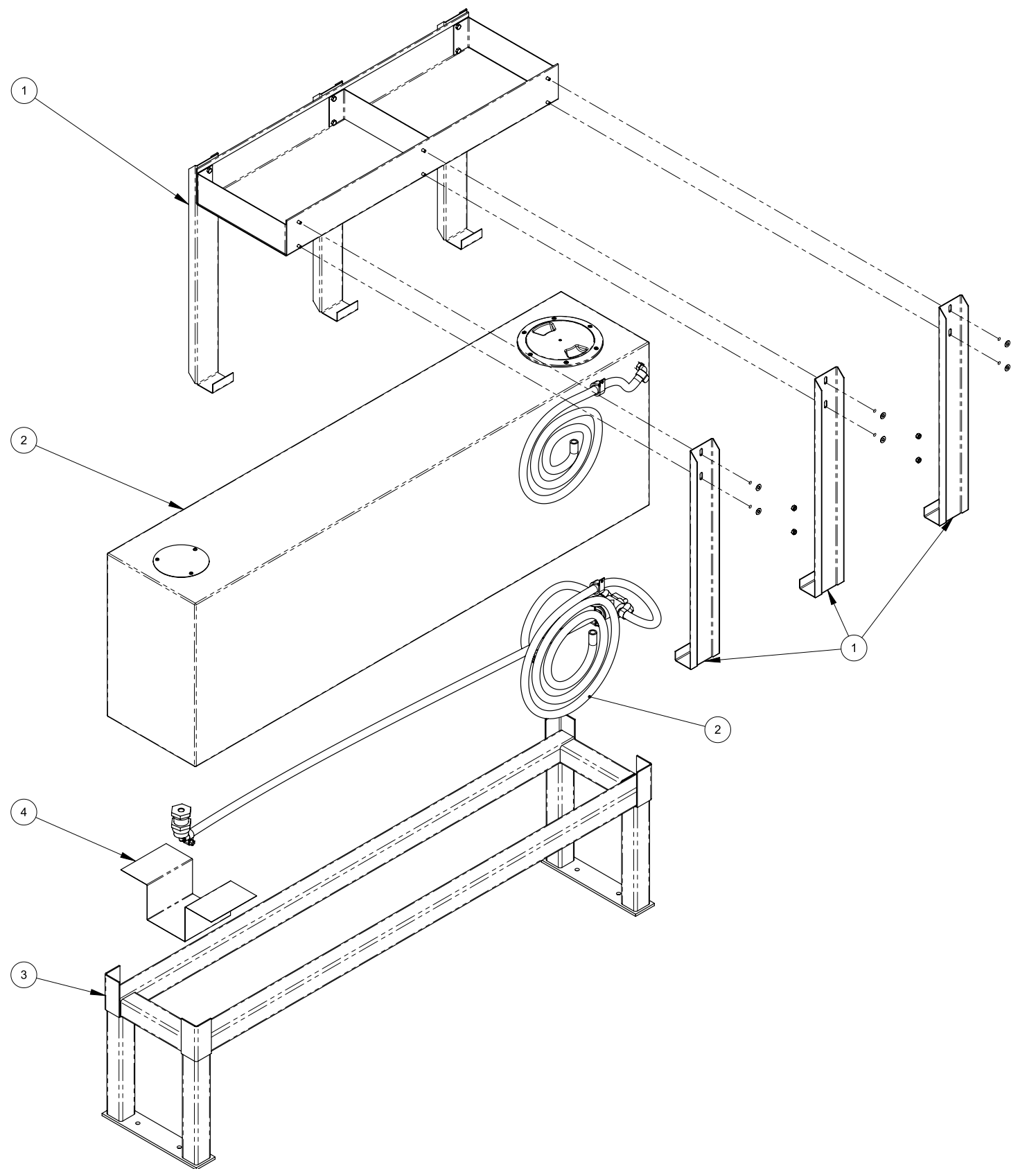
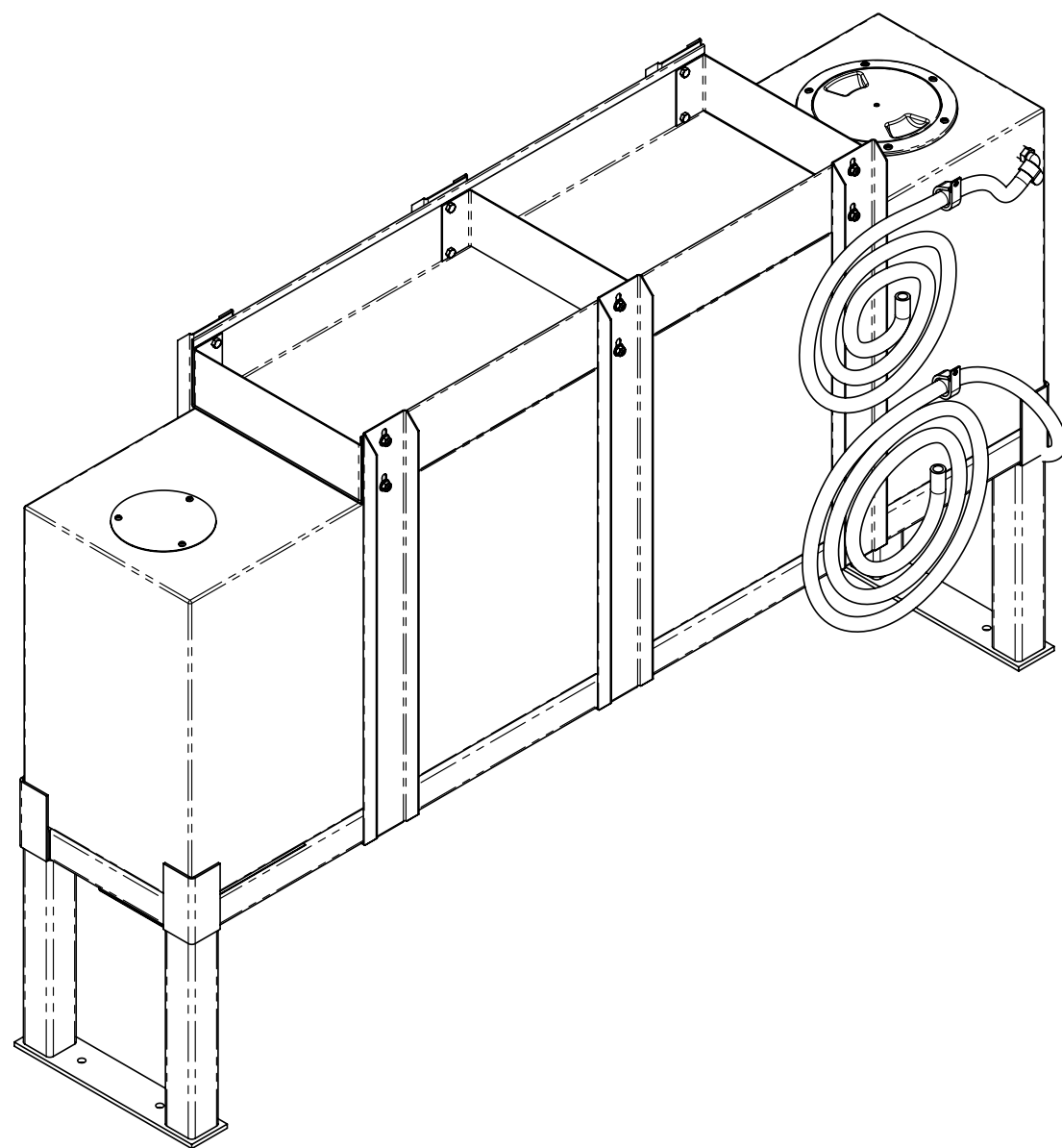
Item	Part Number	Description	Qty
1	000-052-923	BULKHEAD	2
2	000-033-057	CLAMP, 1" CUSHION LOOP	5
3	000-033-004	CLAMP, SIZE #6 MINI HOSE	11
4	000-041-005	COVER, 6" ACCESS	2
5	000-052-484	ELBOW, 1/2" NPT X 1/2 HOSE	2
6	000-052-355	ELBOW, 3/8" NPT x 1/2" HOSE	2
7	000-057-257	GASKET - 5.25 IN. COVER LID	1
8	000-057-256	GASKET - 6 IN. COVER LID	2
9	000-068-674	HOSE, 1/2" I.D. CLR X 16" LG. - BRAID	2
10	000-068-676	HOSE, 1/2" I.D. CLR X 36" LG. - BRAID	2
11	000-068-677	HOSE, 1/2" I.D. CLR X 54" LG. BRAID - DRAIN HOSE	1

Item	Part Number	Description	Qty
12	000-068-678	HOSE, 1/2" I.D. CLRE X 78" LG. BRAID - VENT HOSE	2
13	000-089-003	MAGNET, TREADMASTER	2
14	000-169-588	MINIATURE 3 WAY PVC BALL VALVE	2
15	000-094-034	NUT, #10-24UNC HEX NYLOCK	2
16	000-041-729	PLATE, TANK COVER	1
17	000-106-173	PLUG, 3/8" NPT ALLEN HEAD	2
18	000-143-739	SCREW, #8-15 X 3/4" LG. PAN HEAD SS	15
19	000-143-126	SCREW, #10-24UNC x 0.50" LG. HEX HEAD	2
20	000-159-257	TANK, 15 GALLON - MODIFIED	1
21	000-159-258	TANK, 35 GALLON - MODIFIED	1

NOTICE

The following items are shipped with the Tank Assembly in a plastic bag, ready to be used at installation: Item 2, 2X; Item 3, 2X; Item 6, 2X ; Item 12, 2X; Item 17, 2X.

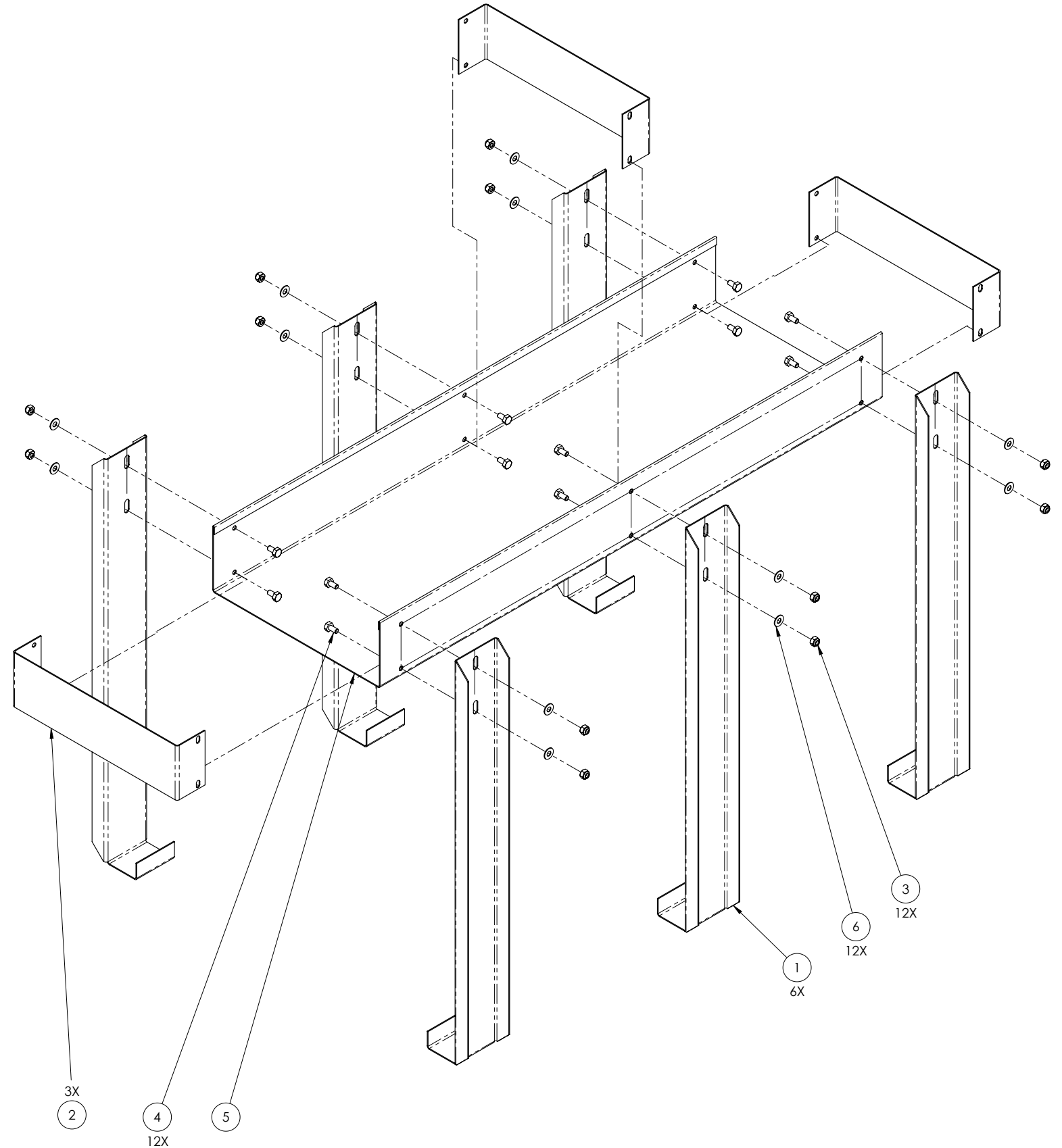
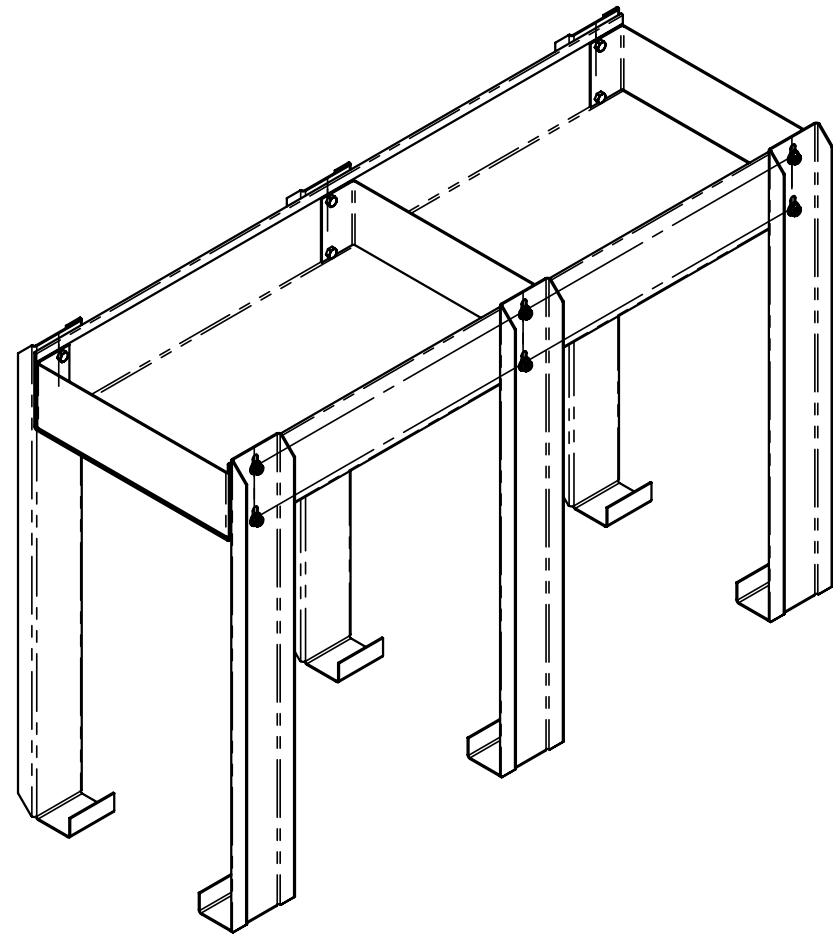
Figure 8-44. 50 Gallon Tank Flex Kit Assembly
000-163-751 Rev. C



50 Gallon Tank Flex Kit Assembly Parts List

Item	Part Number	Description	Qty
1	000-163-756	Assembly, Chemical Caddy 50 Gallon	1
2	000-163-750	Assembly, Tank 50 Gallon	1
3	000-055-215	Frame, 12" X 60" Tank - Coated	1
4	000-108-196	Protector, Bulkhead	1

Figure 8-45. 50 Gallon Tank Flex Chemical Caddy Assembly
000-163-756 Rev. B



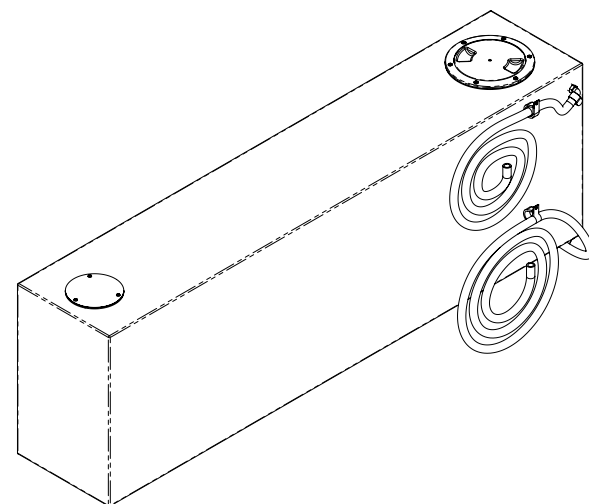
50 Gallon Tank Flex Chemical Caddy Assembly Parts List

Item	Part Number	Description	Qty
1	000-015-1265	Bracket, Tank Stiffener	6
2	000-015-1264	Bracket, Tank Tray Rib	3
3	000-094-071	Nut, 1/4"-20UNC Nylock Half	12
4	000-143-333	Screw, 1/4"-20UNC X 0.50" Lg. Hex Head	12
5	000-166-178	Tray, Tank - 36"	1
6	000-174-003	Washer, 1/4" Flat	12

Figure 8-46. 50 Gallon Tank Flex Assembly
000-163-750 Rev. F

NOTICE

The following items are shipped with the Tank Assembly in a plastic bag, ready to be used at installation: Item 2, 1X; Item 3 1X; Item 6; Item 11; Item 16.



50 Gallon Tank Flex Assembly Parts List

Item	Part Number	Description	Qty
1	000-052-923	BULKHEAD	1
2	000-033-057	CLAMP, 1" CUSHION LOOP	3
3	000-033-004	CLAMP, SIZE #6 MINI HOSE	6
4	000-041-005	COVER, 6" ACCESS	1
5	000-052-484	ELBOW, 1/2" NPT X 1/2 HOSE	1
6	000-052-355	ELBOW, 3/8" NPT x 1/2" HOSE	1
7	000-057-257	GASKET - 5.25 IN COVER LID	1
8	000-057-256	GASKET - 6 IN. COVER LID	1
9	000-068-674	HOSE, 1/2" I.D. CLR X 16" LG. BRAID	1
10	000-068-677	HOSE, 1/2" I.D. CLR X 54" BRAID	2
11	000-068-678	HOSE, 1/2" I.D. CLR X 78" LG. BRAID - VENT	1
12	000-089-003	MAGNET, TREADMASTER	1
13	000-169-588	MINIATURE 3 WAY PVC BALL VALVE	1
14	000-094-034	NUT, #10-24UNC HEX NYLOCK	1
15	000-041-729	PLATE, TANK COVER	1
16	000-106-173	PLUG, 3/8" NPT ALLEN HEAD	1
17	000-143-739	SCREW, #8-15 X 3/4" LG. PAN HEAD SS	9
18	000-143-126	SCREW, #10-24UNC x 0.50" LG. HEX HEAD	1
19	000-159-259	TANK, 50 GALLON - MODIFIED	1

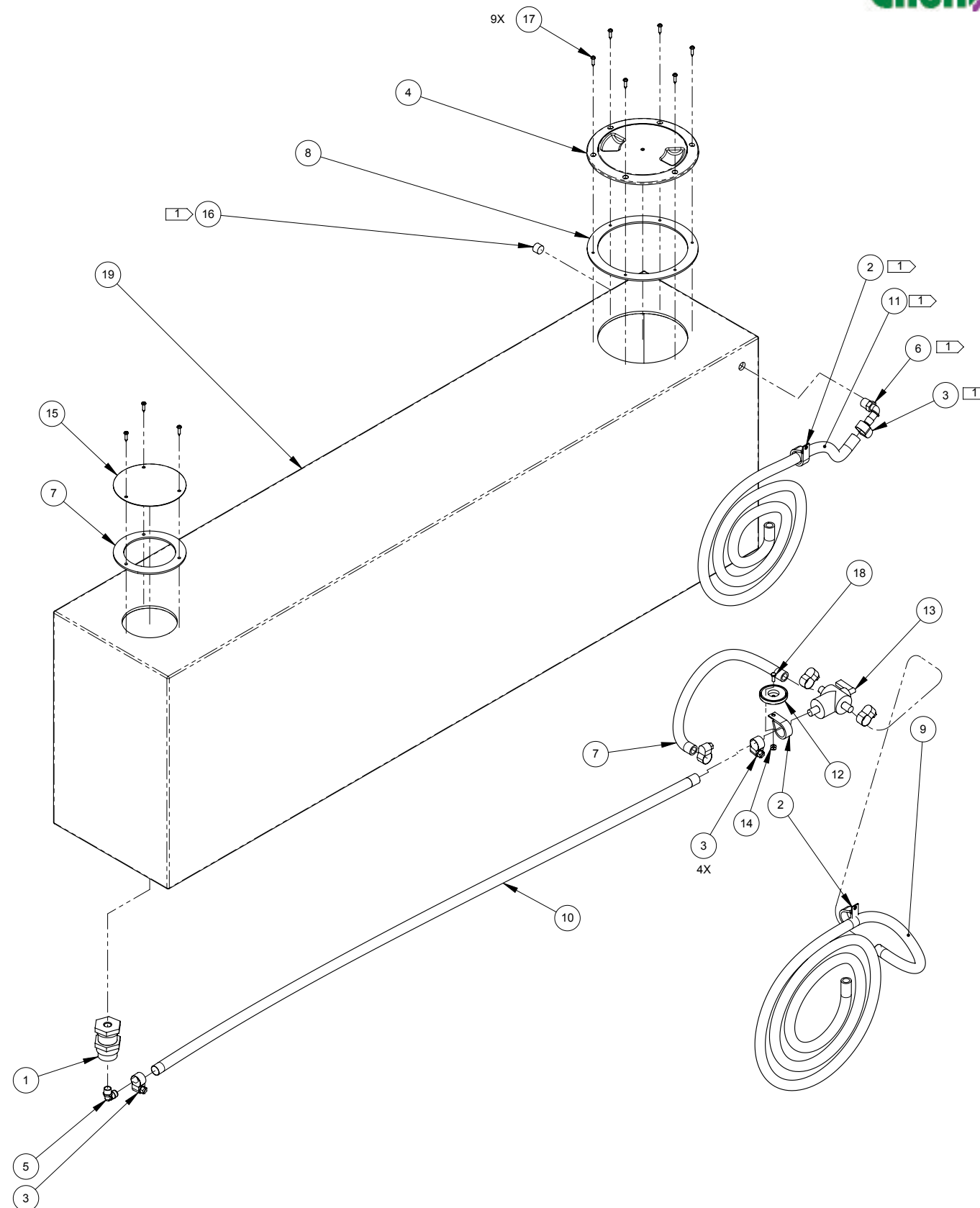
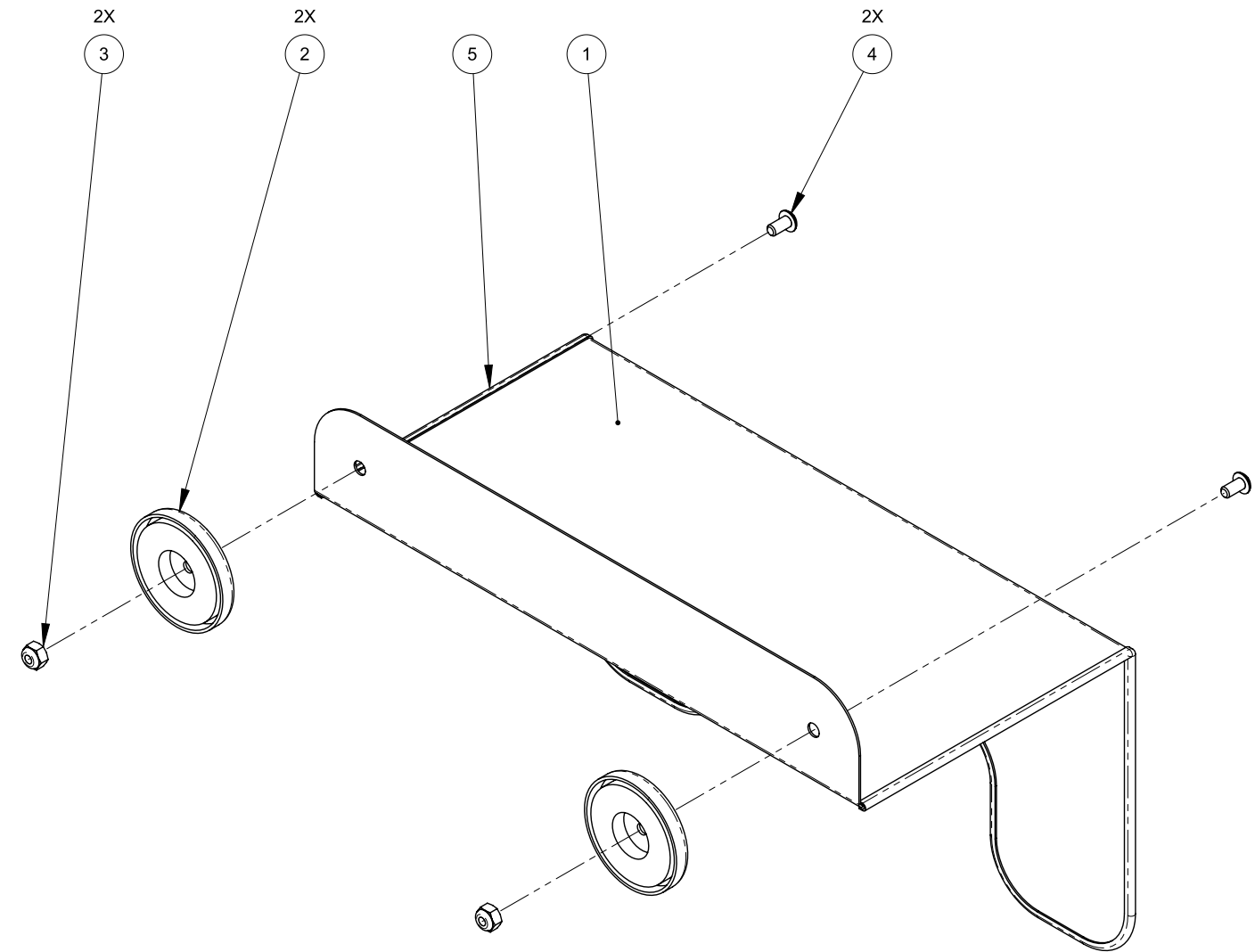
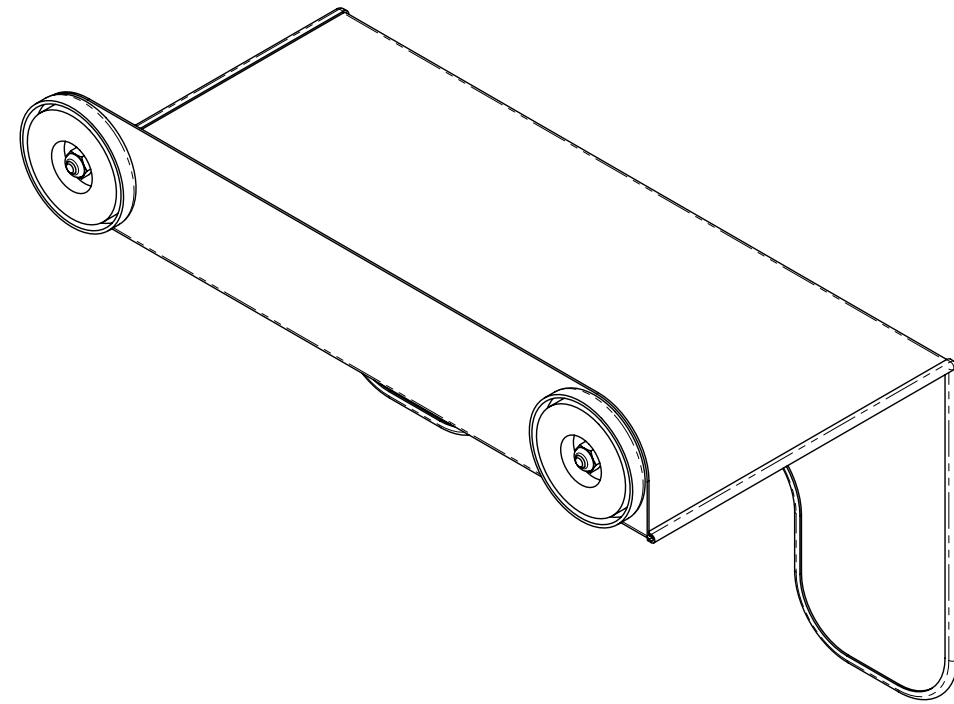


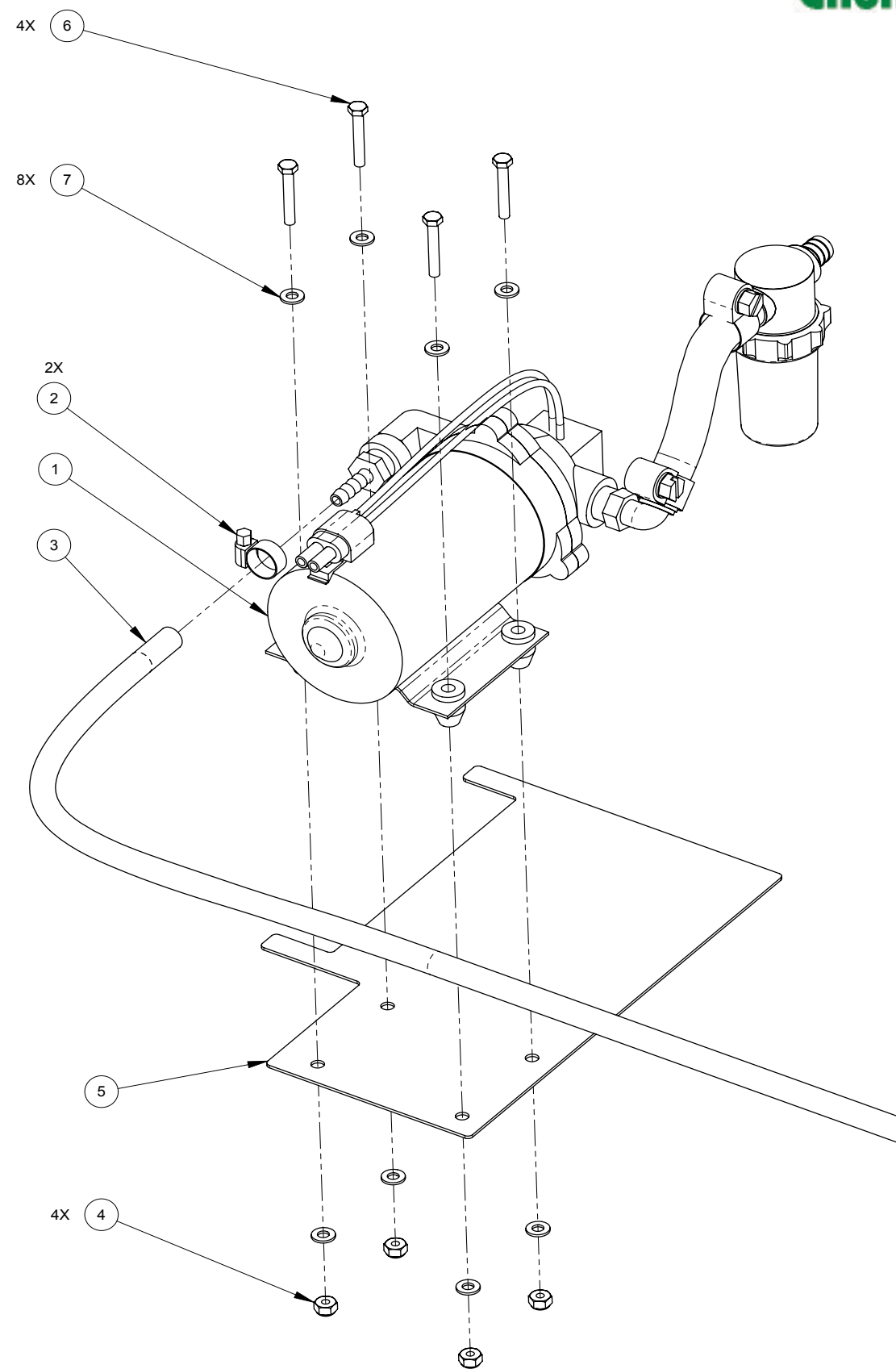
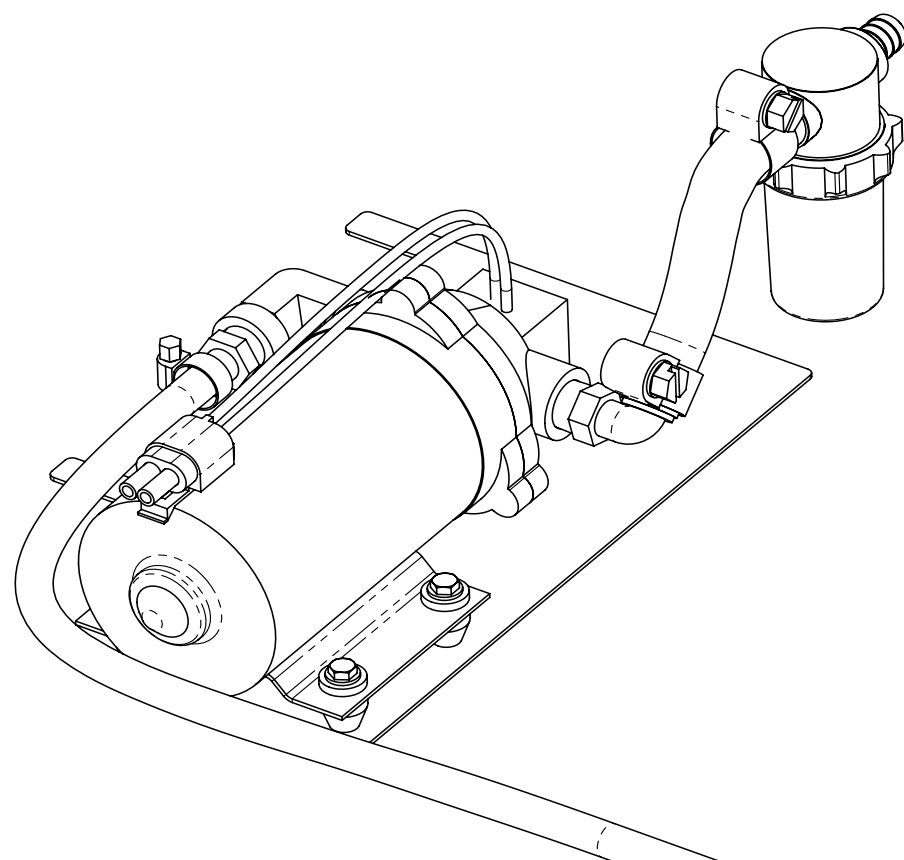
Figure 8-47. Pump Cover Assembly
000-041-707 Rev. B



Pump Cover Flex Assembly Parts List

Item	Part Number	Description	Qty
1	000-041-706	Cover, Pump	1
2	000-089-003	Magnet	2
3	000-094-034	Nut, #10-24UNC Nylock	2
4	000-143-107	Screw, #10-24UNC X 0.375" Lg. Button Head Socket	2
5	000-131-027	Trimlok, 1/8" X 3/8"	2 ft

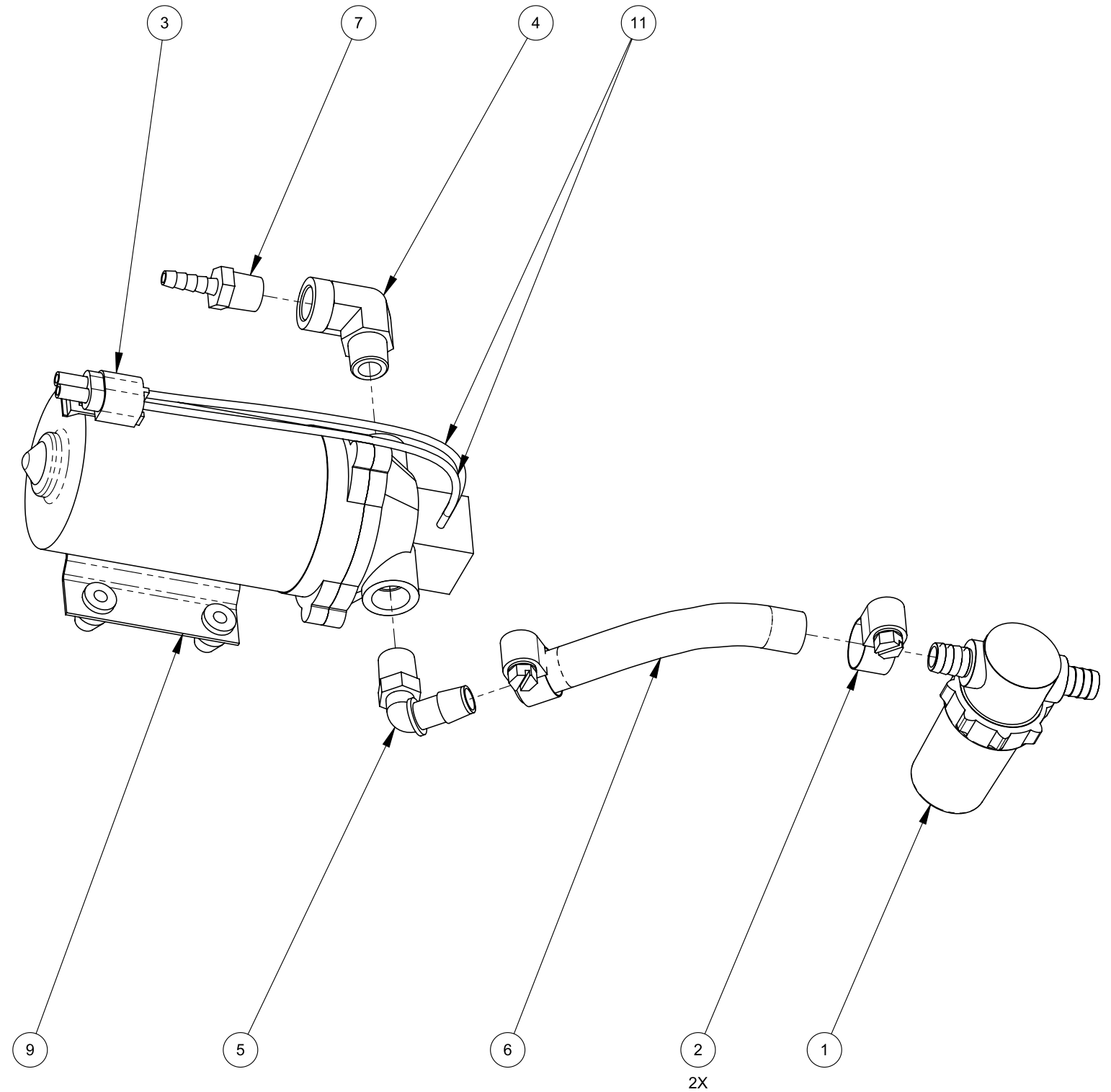
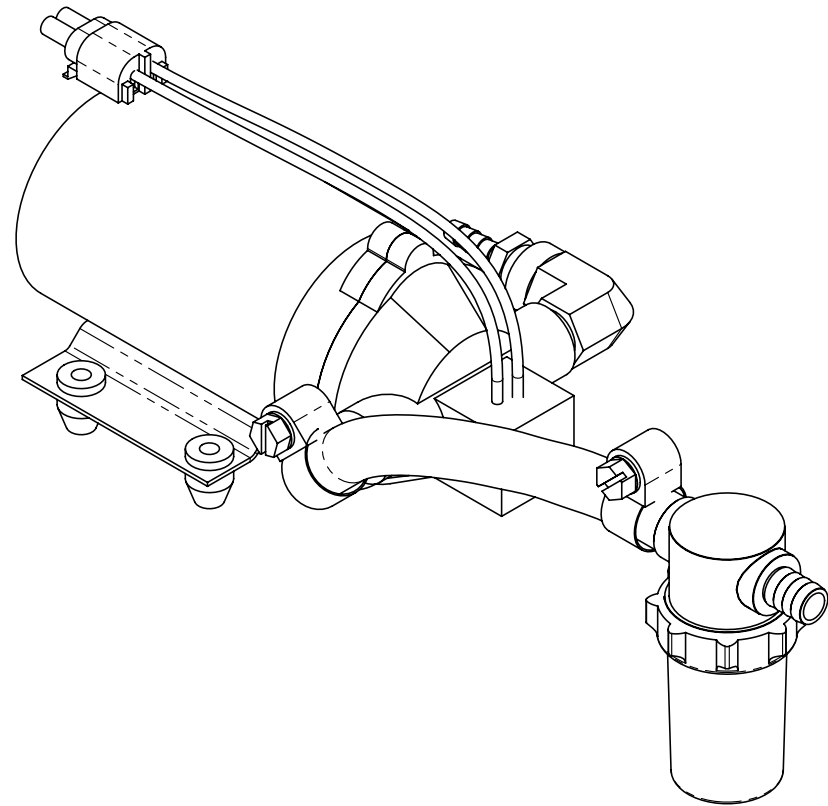
Figure 8-48. Pump - Passenger Flex Kit
601-021-752 Rev. C



Passenger Side Pump Kit Assembly Parts List

Item	Part Number	Description	Qty
1	601-021-800	Assembly, Flex Pump	1
2	000-033-003	Clamp, Size #4 Mini Hose	2
3	000-068-680	Hose, 1/4" I.D. Rubber X 173" Lg. - Pump to Cross	1
4	000-094-034	Nut, #10-24UNC Nylock	4
5	000-105-705	Plate, Pump Mounting	1
6	000-143-171	Screw, #10-24UNC X 1.25" Lg. Hex Head	4
7	000-174-001	Washer, #10 Flat	8

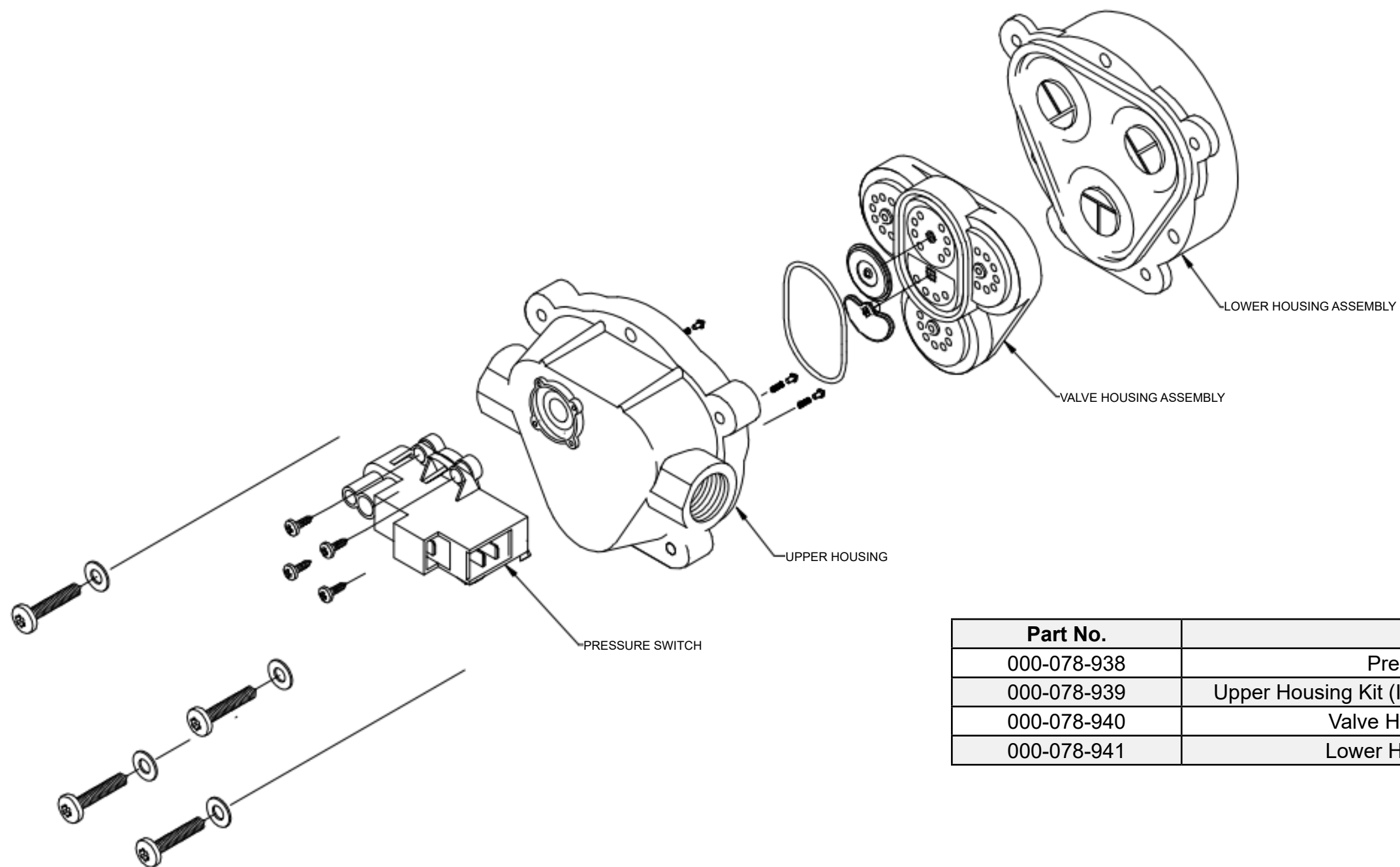
Figure 8-49. Flex Pump Assembly
601-021-800 Rev. B



Flex Pump Assembly Parts List

Item	Part Number	Description	Qty
1	000-049-588	Strainer	1
2	000-033-004	Clamp, Size #6 Mini Hose	2
3	000-037-048	Connector, 2 Pole Water Tight Female	1
4	000-052-747	Elbow, 3/8 S/S Street 90	1
5	000-052-355	Elbow, 3/8" NPT X 1/2" Hose, GFBN	1
6	000-068-1032	Hose, 1/2" I.D. PVC X 8" Lg. - Braided - Pump to Strainer	1
7	000-052-749	Insert, #64 (3/8" NPT X 1/4" Barb) S/S	1
8	000-037-051	Pin, Female	2
9	000-111-588	Pump	1
10	000-147-030	Seal, Water Tite Wire Connector	2
11	000-063-021	Wire, 1/4" Loom	1.5 ft

Figure 8-50. Flex Pump Replacement Parts Kits-
Applies to Both 601-021-752 & 601-021-800



Part No.	Description
000-078-938	Pressure Switch Kit
000-078-939	Upper Housing Kit (Includes the Pressure Switch Kit)
000-078-940	Valve Housing Assembly Kit
000-078-941	Lower Housing Assembly Kit



Console Hose Routings

Part No.	Description	Hose Routing	
		From	to
000-068-977	HOSE, 5/32" I.D. VACUUM X 82" LG.	BLOWER	VAC GAUGE
000-068-978	HOSE, 5/32" I.D. VACUUM X 52" LG.	BLOWER	LUBE PORT
000-068-347	HOSE, 5/32" I.D. VACUUM X 36" LG.	SOL INLET	ENGINE TEE
000-068-1009	HOSE, 5/32" I.D. VACUUM X 16" LG.	SOL VAVLE	AIR CYLINDER
000-068-348	HOSE, 5/32" I.D. VACUUM X 14" LG.	SOL VAVLE	IR CYLINDER
000-068-1059	HOSE, 3/4" I.D. RUBBER x 56" LG.	PUMP	WB
000-068-1133	HOSE, 1/8" HI-TEMP SILICONE X 40" LG. BLACK VACUUM	HXER PLENUM	BACK PRESSURE SENSOR
000-068-997	HOSE, 1/4" I.D. RUBBER X 60" LG.	POP OFF VALVE	THERMO VALVE TEE
000-068-969	HOSE, 1/2" I.D. RUBBER x 69" LG.	FRESH WATER IN	WB
000-068-968	HOSE, 1/2" I.D. RUBBER x 56" LG.	PUMP	WB
000-068-967	HOSE, 1/2" I.D. RUBBER x 20" LG.	WB	DRAIN
000-068-724	HOSE ASSEMBLY, 5/16" TEFLON X 18" LG.	HX	SOL OUT
000-068-760	HOSE ASSEMBLY, 3/16" TEFLON X 71" LG.	HX	CHEMDRY SOL OUT
000-068-627	HOSE ASSEMBLY, 3/16" TEFLON X 44" LG.	ORIFICE	REC TANK
000-068-203	HOSE ASSEMBLY, 3/16" TEFLON X 34" LG.	ORIFICE ASSY	WB
000-068-888	HOSE ASSEMBLY, 3/16" TEFLON X 24" LG.	HX	ORIFICE ASSY
000-068-518	HOSE ASSEMBLY, 3/16" TEFLON X 18.25" LG.	PUMP	GAUGE
000-068-588	HOSE ASSEMBLY, THROB 52" LG.	HX	PUMP

9 - How to Order Parts

This section describes how to obtain a proper diagnosis of any malfunctions, and how to order warranty replacement parts or repairs as outlined in the following areas:

- Warranty Parts Orders
- Parts Orders
- Emergencies

WARRANTY PARTS ORDERS

1. Call the local distributor where you purchased your equipment and ask for the Service Department.
2. Have the following information ready:
 - a. Equipment Model
 - b. Date of Purchase
 - c. Hours on the Unit
 - d. Unit Serial Number
 - e. Description of Malfunction
3. Once it has been determined which parts are needed to correct the problem with your truckmount, make arrangements with your distributor to either perform the repairs or ship the parts to you.

We shall always endeavor to be fair in our evaluation of your warranty claim, and shall provide you with a complete analysis of our findings.

HydraMaster warranty covers only defective materials and/or workmanship for the periods listed. **Diagnostic reimbursement is specifically excluded.**

PARTS ORDERS

Call your local distributor. In most instances, they either stock or have access to parts through a regional service center.

EMERGENCIES

If, for any reason, your distributor is unable to supply you with the necessary parts, they may call us and arrange for expedited shipping.

HydraMaster sells parts only through authorized distributors and service centers.



10 - Warranty Information

To avoid misunderstandings which might occur between machine owners and the manufacturer, we are listing causes of component failure that specifically voids warranty coverage. Such causes listed in this section shall constitute abuse or neglect.

BLOWER

- Failure to maintain proper oil levels, or to use the correct oil grade and viscosity as recommended in blower manual.
- Failure to properly maintain blower safeguard systems such as waste tank filter screen, vacuum safety relief valve and waste tank automatic shut-off system.
- Allowing foam to pass through blower.

HIGH PRESSURE WATER PUMP

- Failure to maintain proper oil level as recommended in pump manual.
- Failure to change oil in pump at recommended intervals.
- Failure to protect pump against freezing.
- Failure to maintain pump protection shut-off system.
- Failure to use water softener in hard water areas.
- Use of improper chemicals.

RECOVERY TANK

- Failure to properly maintain filtering devices in tank.
- Failure to clean tank as recommended by manufacturer.
- Failure to maintain vacuum safety release in tank.
- Use of improper chemicals.

CHEMICAL SYSTEM

- Use of improper chemical.
- Operating machine without proper chemical filter screen.
- Failure to protect against freezing.

CONTROL PANEL

- Failure to protect flowmeter and water pressure gauge against freezing.



VACUUM AND SOLUTION HOSES

- Failure to protect hoses against freezing.
- Failure to protect hoses against burns from engine and blower exhaust.
- Damage to hoses from being run over by vehicles.
- Kinking or cracking from failure to store or unroll hoses correctly.
- Normal wear and tear from everyday use.

CLEANING WAND AND TOOL

- Failure to protect against freezing.
- Obvious physical abuse of wand or tool.

WATER HEATING SYSTEM

- Over-pressurization of the system (recommended maximum working pressure - 1,000 psi).
- Failure to protect against freezing.

HARD WATER DEPOSITS

- Failure to use or maintain a water softening system or a properly installed magnetic-type descaler, whichever might be necessary, with machines operating in designated "Hard Water Areas" (3.5 grains or more per gallon).



HYDRAMASTER® LIMITED WARRANTY

HydraMaster warrants to the original end user, each new machine, new accessories and genuine replacement parts against defects in material and workmanship under normal use and service. Our obligation under this warranty is limited to repair or replacement of the defective item at our factory or by an Authorized Service Center. Warranty coverage shall begin on the date of purchase by the original end user (as evidenced by your invoice from the factory or Authorized Dealer) or six (6) months from the date the machine was shipped from the factory, whichever is earlier. The warranty registration card must be completed and returned within 30 days of purchase. The warranty coverage period is specified below.

GROUP	Parts ^{1,2}	Labor ²
Frame	3 Years	2 Years
Covers	3 Years	2 Years
Vacuum Recovery Tank (Structural only)	3 Years	2 Years
Vacuum Pump	See Note 3	2 Years
Chemical Systems	2 Years	2 Years
Hoses, Internal Machine	2 Years	2 Years
Hoses, External Machine	2 Years	2 Years
Valve, High pressure bypass	2 Years	2 Years
Water Heating System	2 Years	2 Years
Pump, High pressure water	See Note 3	2 Years
Belts	2 Years	2 Years
Fittings, internal machine	2 Years	2 Years
Filter Screens	2 Years	2 Years
Gauges	2 Years	2 Years
Electrical Components	2 Years	2 Years
Engine	See Note 3	2 Years
Accessories and Fresh Water Tanks	1 Year	1 Year
Replacement Parts ⁴	90 Days	NA
NOTES:		
1-Parts repaired or replaced are guaranteed for the remainder of the original machine warranty period.		
2-Coverage only applicable to products sold and used in the United States and Canada.		
3-As provided by the original Manufacturer.		
4-Applies to replacement parts only after machine warranty coverage has expired.		

This warranty shall not apply to repairs resulting from accidents or misuse, damage in transit, overloading the capacity of the machine, failure due to lack of proper maintenance or care as described in the operating and maintenance instructions. Freezing of any water or chemical related component will VOID all warranties on water or chemical related components, internal or external. Corrosion, deposits and/or build-up in the water, chemical, recovery or heating systems due to hardness in the water used or chemicals which result in deposits, will VOID all warranties on affected components. The use or application of any chemical, including but not limited to acids or solvents, which results in damage to metal, rubber, plastic, or painted parts will VOID all warranties on those parts. Minor adjustments, such as tightening of screws or bolts not connected with the replacement of parts, are not covered. Replacement of expendable wear items including, but not limited to paint, labels and other cosmetic parts are also not covered. Repairs or alterations by an organization other than the factory or an Authorized Service Center are not covered and will void any HydraMaster warranty as to the parts or systems repaired or altered by a non-authorized organization.

THERE ARE NO WARRANTIES THAT EXTEND BEYOND THE DESCRIPTION OF THE LIMITED WARRANTIES STATED WITHIN. NO OTHER WARRANTY, EXPRESSED OR IMPLIED, INCLUDING BUT NOT LIMITED TO ANY IMPLIED WARRANTY OF MERCHANTABILITY OR FITNESS FOR A PARTICULAR PURPOSE, IS MADE EXCEPT AS EXPRESSLY STATED HEREIN. ANY STATUTORY IMPLIED WARRANTIES, INCLUDING ANY WARRANTY OF MERCHANTABILITY OR FITNESS FOR A PARTICULAR PURPOSE, THAT ARE IMPOSED BY LAW DESPITE THE EXPRESS LIMITATION OR WARRANTIES ABOVE, ARE EXPRESSLY LIMITED TO THE DURATION OF THE WRITTEN WARRANTY. BUYER UNDERSTANDS, ACKNOWLEDGES AND AGREES THAT THE REMEDIES PROVIDED UNDER THIS LIMITED WARRANTY ARE THE SOLE AND EXCLUSIVE REMEDIES AVAILABLE TO THE BUYER. HYDRAMASTER WILL NOT BE LIABLE FOR ANY OTHER OR ADDITIONAL DAMAGES, INCLUDING BUT NOT LIMITED TO INDIRECT, SPECIAL OR CONSEQUENTIAL DAMAGES ARISING OUT OF OR IN CONNECTION WITH THE FURNISHING, PERFORMANCE, USE OF OR INABILITY TO USE THE MACHINE. ANY EXTENSIONS OF OR MODIFICATIONS MADE TO THIS WARRANTY BY A DEALER/DISTRIBUTOR OF HYDRAMASTER ARE THE SOLE RESPONSIBILITY OF THE DEALER/DISTRIBUTOR.

HydraMaster will pay all freight and transportation charges within the United States, via normal ground shipping means, for replacement of parts covered under this warranty. All material must be properly authorized by HydraMaster prior to being returned. When returning, please provide an explanation of the problem and include the serial number of the machine as well as the name of the selling organization. All defective material must be returned to HydraMaster within 60 days of authorization. The Technical Service department of the authorized Dealer Service Center or the factory will investigate and then contact you.

Transportation of hazardous waste or contaminated equipment is subject to various laws and regulations. In returning machines, parts, or accessories under this limited warranty, the end user must certify in writing that the machines, parts or accessories being returned have not been used for handling, clean up, or disposal of hazardous waste or hazardous materials including but not limited to such things as asbestos, anthrax etc. or if the machines, parts or accessories being returned have been used for handling, clean up, or disposal of hazardous waste or hazardous materials, then the end user must have the machines, parts or accessories decontaminated by licensed and qualified decontamination professionals and provide written certification of this decontamination signed by the decontamination professionals. These machines, parts or accessories are to be returned only to the local HydraMaster Authorized Service Center for Warranty service along with decontamination certification.

HydraMaster reserves the right to change its warranty policy without notice.

FLEX SYSTEM WARRANTY - ADDENDUM TO THE HYDRAMASTER STANDARD LIMITED WARRANTY

Flex System items which are not included in HydraMaster Standard Limited Warranty:

- Flex tank assemblies
- Flex diaphragm pumps
- Strainers

These listed items are covered for one (1) year only.

