



RX-20 Rotary Extractor Owner's Manual

Models 700-041-320 and 700-041-321

MAN-46011 Rev. C, August 8, 2014
(P/N 000-182-170)

No part of this manual may be reproduced or used in any form or by any means (i.e. graphic, electronic, photocopying or electronic retrieval systems) without the express written permission of the manufacturer. Specifications and information in this document are subject to change without prior notice. All rights reserved. © 2014



000-182-170

This page intentionally left blank.

Table of Contents

INTRODUCTION	SECTION 1
Contact Information.....	1-2
Warnings, Cautions and Notices.....	1-3
MACHINE SPECIFICATIONS	SECTION 2
ASSEMBLY INSTRUCTIONS	SECTION 3
OPERATING INSTRUCTIONS	SECTION 4
Preparation	4-1
Operation	4-2
CLEANING INFORMATION	SECTION 5
Cleaning Patterns	5-1
Special Information	5-2
Cleaning Hints.....	5-2
MACHINE MAINTENANCE	SECTION 6
Daily Maintenance	6-1
Periodic Maintenance	6-4
Transport and/or Storage.....	6-5
Freeze Warning and Protection	6-5
ELECTRICAL DIAGRAMS	SECTION 7
ASSEMBLY DRAWINGS AND PARTS LISTS	SECTION 8
Final Assembly Parts List (120 V)	8-4
Final Assembly Parts List (120 V - OS)	8-6
Base and Drive Train Assembly Parts List (120 V).....	8-8
Upper and Lower Handle Assembly Parts List (120 V)	8-11
Vacuum Head Assembly Parts List.....	8-13
Vacuum Head Assembly OS Parts List.....	8-15
Handle Locking Linkage Assembly Parts List	8-16
Gear Box Assembly Parts List	8-17
Vacuum Shoe and Skid Assembly Parts List.....	8-18
Vacuum Shoe and Skid Assembly OS Parts List.....	8-19
Solution Valve Assembly Parts List.....	8-20
Valve Stem Assembly Parts List	8-21

RX-20

REPAIR AND REPLACEMENT	SECTION 9
Felt Vacuum Seal	9-1
High Pressure Valve Assembly	9-2
TROUBLESHOOTING	SECTION 10
WARRANTY INFORMATION.....	SECTION 11
Special Limited Warranty	11-1

List of Figures

Figure 2-1. RX-20 Optional Equipment	2-2
Figure 3-1. Fully Assembled RX-20.....	3-1
Figure 4-1. (1) Pull or Push on Adjustment Lever;	4-1
Figure 4-2. Location of Control Triggers and Momentary Switch	4-2
Figure 4-3. Lift or Lower Handle to Maneuver	4-3
Figure 4-4. Correct Cleaning Patterns.....	4-4
Figure 5-1. Clean into Area or Room.....	5-2
Figure 6-1. Remove Nut/Inline Filter.....	6-1
Figure 6-2. Check Jet Spray for Even Flow.....	6-2
Figure 6-3. Loosen Cleaning Head Assembly	6-2
Figure 6-4. Location of Rotary Union.....	6-2
Figure 6-5. Clean Off Debris from Gear Box Shaft.....	6-3
Figure 6-6. Lubricate Vacuum Seal on Top of Hub.....	6-3
Figure 6-7. Lubricate Shaft and Re-install Head Assembly.....	6-3
Figure 6-8. Remove Retaining Clip with Screwdriver	6-4
Figure 6-9. Tighten Setscrew.....	6-4
Figure 7-1. Wiring Diagram - 120 V, 60 Hz.....	7-1
Figure 8-1. Adhesive and Sealant Material Reference	8-2
Figure 8-2. Final Assembly (120 V)	8-3
Figure 8-3. Final Assembly (120 V - OS).....	8-5
Figure 8-4. Base and Drive Train Assembly (120 V) - View 1 of 2	8-7
Figure 8-5. Base and Drive Train Assembly (120 V) - View 2 of 2	8-8
Figure 8-6. Upper and Lower Handle Assembly (120 V) - View 1 of 2	8-9
Figure 8-7. Upper and Lower Handle Assembly (120 V) - View 2 of 2	8-10
Figure 8-8. Vacuum Head Assembly	8-12
Figure 8-9. Vacuum Head Assembly OS.....	8-14

RX-20

Figure 8-10. Handle Locking Linkage Assembly	8-16
Figure 8-11. Gear Box	8-17
Figure 8-12. Vacuum Shoe and Skid Assembly	8-18
Figure 8-13. Vacuum Shoe and Skid Assembly OS	8-19
Figure 8-14. Solution Valve Assembly	8-20
Figure 8-15. Valve Stem Assembly.....	8-21
Figure 9-1. Carefully Pry Seal Up and Lift Out	9-1
Figure 9-2. Quick Connect, Back Plate and Stainless Steel Hose Removed from Upper Handle Assembly.....	9-2

1- Introduction

Congratulations,

You now own a piece of equipment that incorporates the latest in carpet, tile and grout cleaning technology. Your foresight in purchasing an RX-20 shows that you care enough to give your customer the maximum cleaning process available. You have invested in not only a cleaning tool, but a marketing tool that will enhance your professional image in every way.

The RX-20's features will almost certainly increase your productivity while decreasing the fatigue factor that may have prevented you from going after some of the larger cleaning jobs that are available to carpet cleaners and maintenance professionals today.

Your new RX-20 is a powerful Rotary Jet Extractor that has been precision engineered to bring you to the state-of-the-art in carpet, tile and grout cleaning. The RX-20's weight distribution and rotary motion enable the operator to maneuver the unit easily with less fatigue and without back strain.

The RX-20's electric motor drives its precision transmission which, in turn, rotates the head, or star, assembly.

Cleaning solution is injected through the center of the gear box shaft directly to the three spray jets.

Soiled solution is then extracted from the carpet by five stainless steel cleaning heads and drawn through the aluminum exhaust manifold to your cleaning system's recovery tank.



RX-20

CONTACT INFORMATION

If you have any questions regarding the operation, maintenance or repair of this machine, refer to the following information and contact the appropriate department.

<u>Hours</u>	<u>Telephone Numbers</u>
Monday-Friday	(425) 775-7275 Support
7:00 a.m. to 5:00 p.m.	(425) 775-7276 Parts
Pacific Time	FAX (425) 771-7156 - Parts (800) 426-4225 - Support

When calling your distributor, be sure to reference the serial number and date of purchase.

FOR YOUR REFERENCE:

Serial No. _____

Date of Purchase: _____

Purchased From (Distributor): _____

WARNINGS, CAUTIONS AND NOTICES

WARNING

The manufacturer uses this WARNING symbol throughout the manual to warn of possible injury or death.

CAUTION

This CAUTION symbol is used to warn of possible equipment damage.

NOTICE

This NOTICE symbol indicates that federal or state regulatory laws may apply, and also emphasizes supplemental information.

RX-20

This page intentionally left blank.

2- Machine Specifications

	RX-20 - 120 V
Length	23"
Base Width	16"
Height - Standard	Up to 43"
Weight	70 lbs
Motor	1/2 HP Totally Enclosed Fan-Cooled
Voltage	120 V, 60 Hz
Gear Box	1,725 rpm Input 130 rpm Output Permanently Lubricated Helical Gear Drive
Oil Capacity	12 oz
Star Head Plate	Replaceable, Spring Steel Arms
Cleaning Heads	Five Cast Aluminum
Solution Jets	Three Stainless Steel, 80015 Veejet 80
Solution Strainer	Mesh, Stainless
Solution Valve	Stainless Steel, High Pressure
Cleaning Rate	Five Heads Rotating at 130 rpm = 650 Cleaning Passes/Minute
Handle Assembly	Foam Grips
Transportation Wheels	8" diameter, 1-1/2" Wide; Gray, Non-Marking
Electric Cord	50 ft, 14/3

The base, exhaust manifolds, handle, gear box housing and cleaning heads are all cast aluminum. Other parts are either metal or high impact plastic.

RX-20

NOTICE

The operating temperature and pressure of the cleaning solution as well as the vacuum power depend entirely on the type of cleaning system you use.

OPTIONAL EQUIPMENT

To better meet your business needs, the manufacturer offers these options that you can add to your basic rotary extractor system:

If you want this option:	Order this P/N:
Pad and Bonnet Driver	190-041-020 (Top Photo, Figure 2-1)
Hard Floor Attachment (LD)	190-041-024 (Middle Photo, Figure 2-1)
Hard Floor Attachment (MD)	190-041-026 (Middle Photo, Figure 2-1)
Hard Floor Attachment (HD)	190-041-025 (Middle Photo, Figure 2-1)
Mounting Bracket	000-163-018 (Bottom Photo, Figure 2-1)

RX-20 Pad and Bonnet Driver

Allows the RX-20 to quickly convert to drive either carpet cleaning bonnets or standard hard floor pads
Item#190-041-020

RX-20 Hard Floor Attachment - LD

Suitable for Light Duty (LD) to medium duty cleaning of stone, slate, terrazzo, ceramic tile, grout and sealed concrete floors
Item#190-041-024

RX-20 Hard Floor Attachment -MD

Suitable for Medium Duty (MD) to aggressive scrubbing of resilient floors, terrazzo, quarry tile, ceramic tile, grout and concrete floors
Item#190-041-026

RX-20 Hard Floor Attachment - HD

Designed for Heavy Duty (HD) to most aggressive scrubbing of resilient floors, terrazzo, quarry tile and concrete floors.
Item#190-041-025

RX Mounting Bracket

Keep your RX-20 High Efficiency Model secured in your van with our custom mounting brackets. Simply set the wheels of the extractor in the bracket and your machine will stay in place. No thinking about it rolling around in your van or wasting valuable space by laying it on its side.
Item#163-018



Figure 2-1. RX-20 Optional Equipment

3 - Assembly Instructions

To prepare your RX-20 for use, follow these instructions:

1. Remove the machine from the packaging. Inspect the machine carefully for any damage that may have occurred during shipping.
2. Remove the solid shipping plug from the top of the gear box (see Figure 3-1).
3. Check the gear box lubricant level (see page 6-4 of this Owner's Manual).
4. Insert the vented plug (provided) into the gear box in place of the solid shipping plug. The solid shipping plug may be discarded.
5. Remove the protective wrapping material from the wheels.
6. Attach the cleaning head, or star, assembly to the base of the RX-20 (see Figure 3-1).
 - a. Lean the machine back and rest it on the handle.
 - b. Thread the star assembly (cleaning head) onto the exposed shaft in a counterclockwise direction.

CAUTION

Be sure to remove the solid shipping plug from the top of the gear box and replace it with the vented plug (P/N 000-106-014), provided, before operating the machine (see Figure 3-1). Failure to follow these directions may result in damage to the gear box and seal.

Your RX-20 is now ready to operate.



Figure 3-1. Fully Assembled RX-20

RX-20

This page intentionally left blank.

4 - Operating Instructions

PREPARATION

Handle Adjustment

Pull or push on the adjustment lever to adjust the height of the handles (see Figure 4-1). Several adjustments may be needed before a desirable operating position is found.

NOTICE

Most operators have better control and experience less fatigue when the handle is in a lower position, at the operator's hip line. For each person, there is an ideal position which ensures the RX-20 does the work instead of the individual.

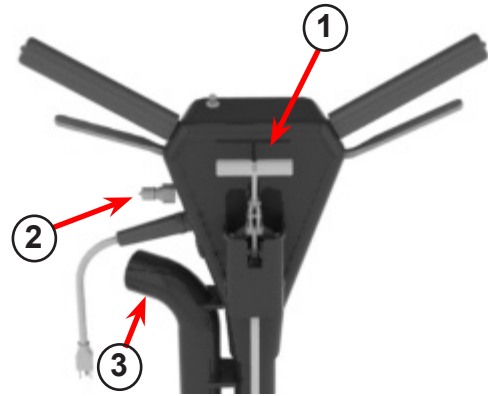

Figure 4-1. (1) Pull or Push on Adjustment Lever; (2) Location of 440 Male Quick Connect; (3) Vacuum Hose Inlet

Solution and Vacuum Hose Connections

Your RX-20 is equipped with a 440 male quick connect for the solution hose connection and a 2" O.D. vacuum hose inlet (see Figure 4-1). The vacuum inlet requires a 2" I.D. vacuum hose for proper air flow with a truckmounted system.

NOTICE

The vacuum hose must be in good condition to ensure maximum airflow.

A solution hose with a 440 female quick connect is also required. If you do not have a 440 female quick connect, please call your distributor to order the part.

RX-20

Electrical Cord Connection

The 50 ft electrical cord on your RX-20 is a permanently attached, three-prong grounded line requiring a three-prong, 15 Amp receptacle.

A three-prong to two-prong adapter may be used if its ground wire is properly attached to a grounded terminal.

⚠ WARNING

Do not, under any circumstances, remove the ground prong from your RX-20 power cord. Serious injury or death may result.

For best results, vacuum the carpet thoroughly prior to using the carpet cleaning system.

OPERATION

Control Functions

Control triggers are located on each side of the handle under the rubber hand grips (see Figure 4-2).

1. To operate the RX-20, squeeze the **motor trigger** on your right-hand side to control the electric motor which drives the cleaning heads (see Figure 4-2).

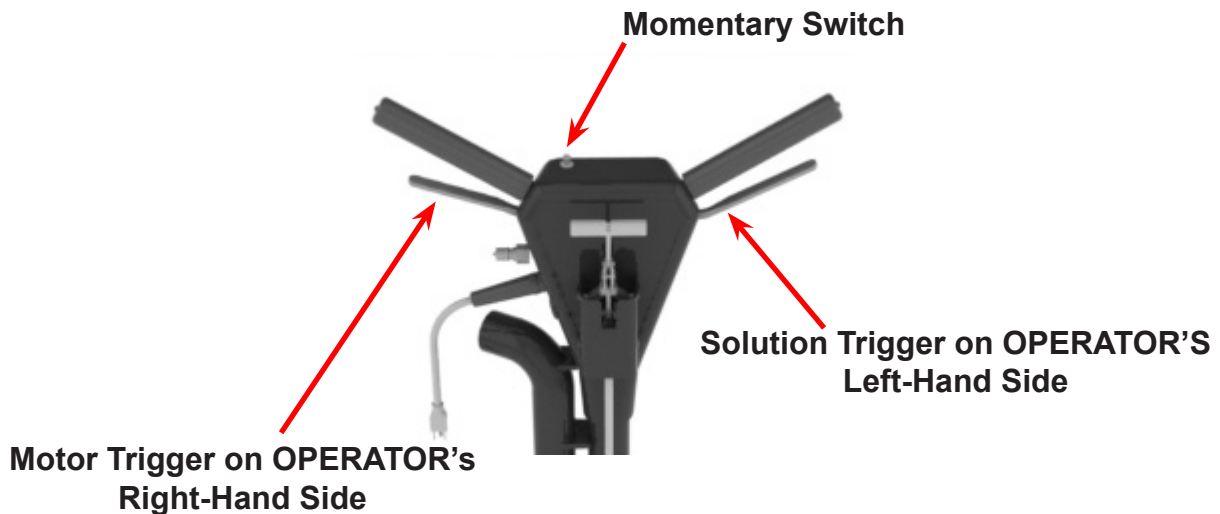

Figure 4-2. Location of Control Triggers and Momentary Switch as Viewed from Front of Machine (Opposite of Operator's Position)

RX-20

2. To fully engage the motor as you are cleaning, you also need to hold down the momentary switch, or button, at the same time as you squeeze the motor trigger (see Figure 4-2). The momentary switch is an integrated safety feature on the RX-20 which cuts power to the machine if the operator's hands leave the machine for any reason.
3. On the left-hand side, squeeze the solution trigger to control the high pressure solution spray (see Figure 4-2).

Notice that the air flows constantly while the RX-20 is in operation.

CAUTION

Do not operate your RX-20 on dry carpets. The friction generated by the revolving cleaning heads may damage fibers in the carpet.

Maneuvering Your RX-20

Your RX-20 maneuvers like a rotary floor machine.

1. To move the RX-20 to the right, lift the handle slightly (see Figure 4-3). The more you lift or lower the handle, the faster the RX-20 will move.

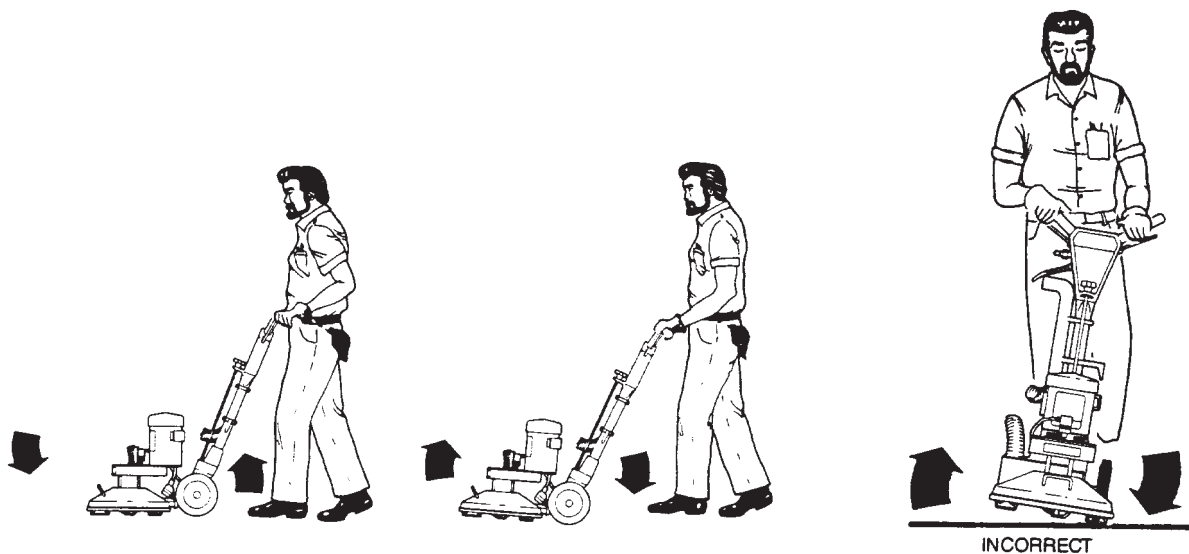

Figure 4-3. Lift or Lower Handle to Maneuver; Illustration to the Right Shows Incorrect Maneuver

RX-20

2. To move forward and backward, position the handle so that the unit remains stationary, then push forward or pull back. To familiarize yourself with your RX-20, practice on an open area. Depress both the solution trigger and motor trigger and move the RX-20 slowly in a 3 to 5-ft arc, as shown in Figure 4-4.

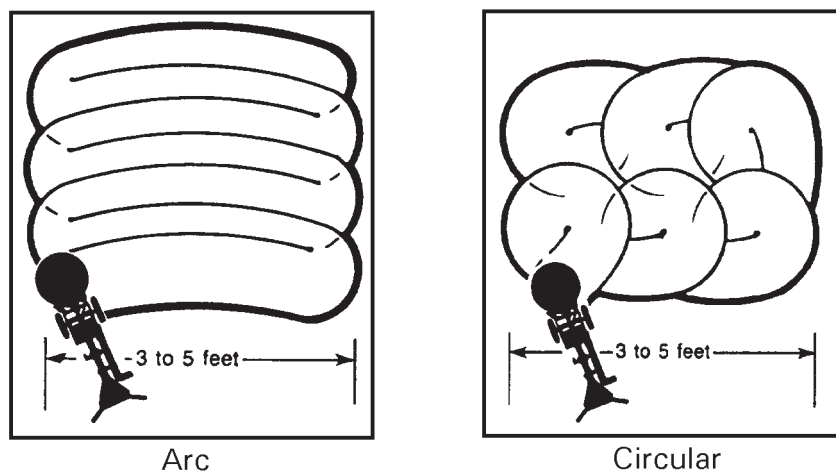

Figure 4-4. Correct Cleaning Patterns

After you have become familiar with the speed and movement of the machine, practice making it hover in one spot. (The hovering maneuver is useful for removing stubborn stains, as well as removing furniture indentions.)

CAUTION

Do not tilt RX-20 sideways while moving forward and backward. A loss of control may result in damage to the unit or cleaning area.

5 - Cleaning Information

CLEANING PATTERNS

For regular carpet cleaning use an overlapping arc pattern three times over the same area (two passes with solution and one pass for drying). When cleaning carpets, first clean in circular pattern, then use the overlapping arc pattern to dry the area.

NOTICE

Dirtiest areas may require two or more cleaning passes. Using either pattern shown in Figure 4-4, you should develop a comfortable rhythm. To obtain maximum performance from your RX-20, move it slowly and deliberately with a 50% overlap, giving it time to clean and extract. A steady pace rather than a frenzied one will increase efficiency and production, and decrease fatigue.

CAUTION

The following cautions should be observed while cleaning:

1. DO NOT operate your RX-20 over metal floor moldings. Damage to both the molding and the cleaning head will result.
2. DO NOT operate your RX-20 on hardwood floors.
3. DO NOT operate your RX-20 over loose or unraveled carpet seams. The cleaning head may catch and cause further damage.
4. DO NOT operate your RX-20 on concrete floors. It will develop sharp edges on the extraction heads that will damage carpet fibers.
5. DO NOT clean over the edge of a loose carpet. Instead, clean only up to the edge. Damage may occur if the extraction heads catch the loose carpet.

RX-20

SPECIAL INFORMATION

When you clean some plush carpets, you may notice a “pilling” effect. (Pilling occurs when fluffy particles appear on carpet surfaces; it is caused by fibers that loosen because of a weak twist or snags.)

With an RX-20, loose yarns form balls and are kicked aside as the cleaning heads revolve. This is normal when aggressive cleaning or even normal vacuuming takes place, as evidenced by a number of dead, loose yarns in the vacuum cleaner bag. These loose yarns, in most cases, are short staple yarns or filler yarns used to give the carpet a denser appearance.

Because your RX-20 weighs approximately 70 lbs and rests on five 4” cleaning heads, the yarns are not sucked up into the vacuum heads as they are with a vacuum cleaner or old-style cleaning wand.

CAUTION

On older, rubber backed, glued down carpets that may be delaminating with age, the RX-20 may cause further delamination. When in doubt, DO NOT use your RX-20 on such carpets.

CLEANING HINTS

1. Most cleaners customarily clean their way out of an area or room. With the RX-20, you can clean into an area or room, as shown in the Figure 5-1, so that the hoses are dragged behind you during the cleaning process rather than kicked out of the way as you back out of an area. The “cleaning into” method works especially well in hallways or confined areas.
2. The RX-20 is a very aggressive carpet cleaning power head and will leave the carpet with a freshly cleaned appearance. The carpet should be brushed or groomed after the cleaning process to remove any swirl marks left behind.
3. The RX-20 has been very successful in restoring badly matted traffic lanes in front of doorways and sofas. Even pivot areas can be brought back to life again, in most cases. “Cornrowing” in hallways can also be eliminated with minimal effort.

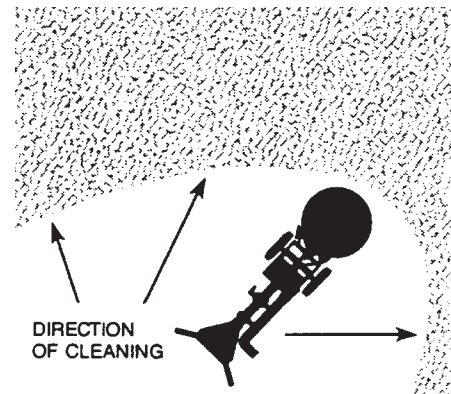

Figure 5-1. Clean into Area or Room

6 - Machine Maintenance

Good care and regular maintenance of your RX-20 will result in a long, dependable life for the unit. Keep in mind that your RX-20 will be in full view of your customer. An RX-20 that is dirty and unkempt in appearance can cause your business or professional image to suffer. You are offering your customer the latest in cleaning technology. Therefore, it is important that your company image reflect your desire to give your customer the best.

The surface finish on your RX-20 is a durable, powder coating and is easily cleaned with a damp cloth. To further protect the finish, a light coat of good silicon base polish should be applied periodically.

Lubrication and maintenance play a key role in the life of your RX-20. Hence, the following daily and periodic maintenance steps must be followed. Train yourself to maintain your unit on a regular schedule until it becomes habitual.

DAILY MAINTENANCE

1. Disconnect the RX-20 from the power source and inspect its power cord for cuts, breaks and abrasions. Repair or replace as needed.
2. Inspect the vacuum hoses for breaks or tears. Repair or replace as necessary.
3. Visually inspect your RX-20 for water leaks, wear damage to the cleaning heads, and so forth. Repair or replace as necessary.
4. Remove the inline solution filter screen by unfastening the nut showing through the cut out on the back panel using a 15/16" wrench. Remove the nut which houses the inline filter (see Figure 6-1).
5. Rinse it under water to remove debris. If necessary, use a toothbrush to remove stubborn particles.
6. Before re-inserting the nut/inline filter, check the O-ring on the inside of the nut/inline filter. If the O-ring is cracked or damaged, replace the O-ring.

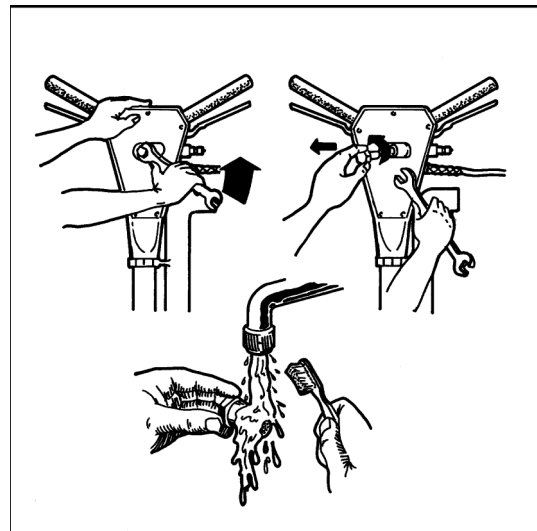

Figure 6-1. Remove Nut/Inline Filter

RX-20

7. Check the spray on the jets for even flow. An uneven spray will cause improper flow of the cleaning solution (see Figure 6-2).

⚠ WARNING

Do NOT spray the high pressure solution in your face or eyes. Bodily injury can result.

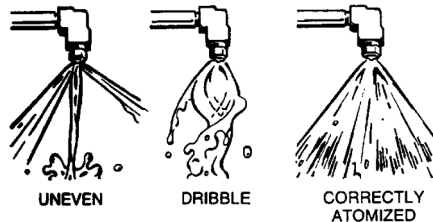

Figure 6-2. Check Jet Spray for Even Flow

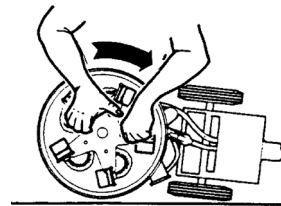

Figure 6-3. Loosen Cleaning Head Assembly

8. Loosen the cleaning head (star assembly). It unscrews in the same direction it turns during operation (or clockwise when looking at it from the underside) - see Figure 6-3.
9. After you have loosened the head assembly, spin it off with your hands. If the cleaning head is difficult to remove, you may use a 3/4" socket wrench on the exposed center nut. To prevent the gear box from turning, insert a 5/8" wrench just below the rotary union (see Figure 6-4).
10. Wash the cleaning heads and shroud assembly with a garden hose, being careful not to wet the electric motor assembly.
11. Clean any lint built up on the cleaning heads and vacuum hoses (lint buildup will restrict proper airflow and prolong drying time).



Figure 6-4. Location of Rotary Union

12. Clean off any debris that may have accumulated on the gear box shaft or the inside threaded bore of the hub (see Figure 6-5).
13. Lubricate the felt vacuum seal on top of the hub with a quality, 30 weight SAE motor oil. Also, put a few drops into the hub threads (see Figure 6-6).
14. Coat the shaft with TKX® All-Purpose Lube (P/N 000-087-006) or a similar lubricant. Re-install the vacuum head assembly onto the shaft by rotating it counter-clockwise (Figure 6-7).

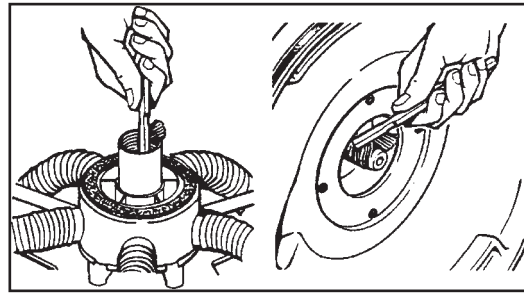

Figure 6-5. Clean Off Debris from Gear Box Shaft

CAUTION

An accumulation of debris in the gear box, if not removed, may damage the gear box oil seal. This will result in loss of oil in the gear box. If the gear box is operated without oil, severe damage may occur.

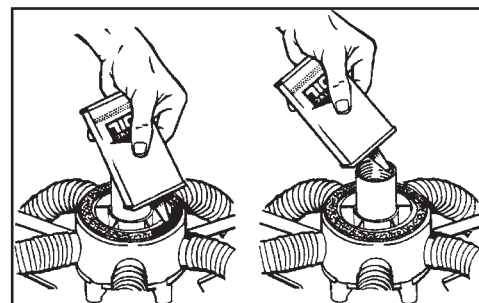

Figure 6-6. Lubricate Vacuum Seal on Top of Hub

CAUTION

While rotating the vacuum head assembly in the counter-clockwise position, make sure that it spins freely all the way down. If it begins to require the slightest finger tip pressure, unscrew it and brush off the threads.

The smallest grain of dirt or sand will obstruct the threads. If you turn too far onto a grain of dirt, the hub may become locked onto the shaft of the gear box.

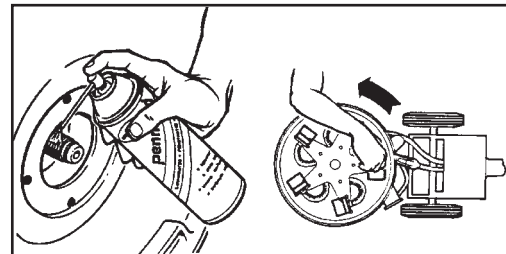

Figure 6-7. Lubricate Shaft and Re-install Head Assembly

RX-20

PERIODIC MAINTENANCE

Check the oil level in the gear box on a monthly basis. This is a permanently lubricated gear box. You do not need to change the oil. However, maintaining the proper oil level is important.

To check the oil level, remove the vent plug and look into the gear box. Turn the star until you can see the inspection hole in the gear. When the RX-20 is sitting flat on a table or the floor, the oil level should be up to, but not above, the middle of the gear. If oil needs to be added, use a quality 80-90 weight gear oil.

NOTICE

When checking the oil level in the gear box, you can use a toothpick as a dip stick. The oil level should read 3/8" deep.

Locking Mechanism

If the locking mechanism becomes loose and fails to hold the handle in position, tighten it by following these simple steps:

1. Remove the retaining clip from one wheel, using a flat-bladed screwdriver (see Figure 6-8).
2. Remove the wheel from one side of the unit.
3. Ensure that the clamp is set to the locking position.
4. Tighten the setscrew as shown in Figure 6-9 to achieve the desired clamping force.
5. Re-install the wheel and retain with the original clip.
6. If the locking mechanism becomes loose again in the future, remove the wheel on the other side of the unit and tighten the other setscrew, in order to even up the wear on the clamping pins.



Figure 6-8. Remove Retaining Clip with Screwdriver



Figure 6-9. Tighten Setscrew

TRANSPORT AND/OR STORAGE

Whenever your RX-20 is transported or stored, recommends that you remove the star assembly (cleaning head). The machine will then sit flat on the floor and remain more stable, especially during transport.

FREEZE WARNING AND PROTECTION

Your RX-20 can suffer damage from freezing, as can any equipment that functions with the use of water. Care must be taken to protect this machine from freezing just as you do your other equipment.

To protect it from freezing, simply blow air from an air hose through the solution quick connect with the valve open. This eliminates water from the valve, solution line, rotary union and jet assembly.

Open and close the valve several times to ensure that all water is removed.

RX-20

This page intentionally left blank.

This page intentionally left blank.

8 - Assembly Drawings and Parts Lists

These are the available RX-20 configurations.

Top Level Part No.	Top Level Description	Includes:		
		Part No.	Description	Qty
700-041-320	RX-20 120 V (60Hz) HS O/S Head	000-057-047	Gasket, Felt Hub	2
		000-081-004	Label Set	1
		604-999-101	Assembly, Final	1
700-041-321	RX-20 120 V (60Hz) HS HE Head	000-057-047	Gasket, Felt Hub	2
		000-081-004	Label Set	1
		604-999-100	Assembly, Final	1

The following major assemblies are detailed in this section:

- Final Assembly Parts List (120 V)
- Final Assembly Parts List (120 V - OS)
- Base and Drive Train Assembly Parts List (120 V)
- Upper and Lower Handle Assembly Parts List (120 V)
- Vacuum Head Assembly Parts List
- Vacuum Head Assembly OS Parts List
- Handle Locking Linkage Assembly Parts List
- Gear Box Assembly Parts List
- Vacuum Shoe and Skid Assembly Parts List
- Vacuum Shoe and Skid Assembly OS Parts List
- Solution Valve Assembly Parts List
- Valve Stem Assembly Parts List

RX-20

Some of the illustrations in this section reference sealants, thread lockers, adhesive, primer, anti-seize and lubricant specifications that can be used in the construction of the manufacturer's equipment.

Refer to Figure 8-1 to identify those substances such as A1, A2 and so forth. Equivalent products are acceptable if they meet or exceed current specifications and are approved by the manufacturer.



Figure 8-1. Adhesive and Sealant Material Reference

Figure 8-2. Final Assembly (120 V)
604-999-100 Rev. E

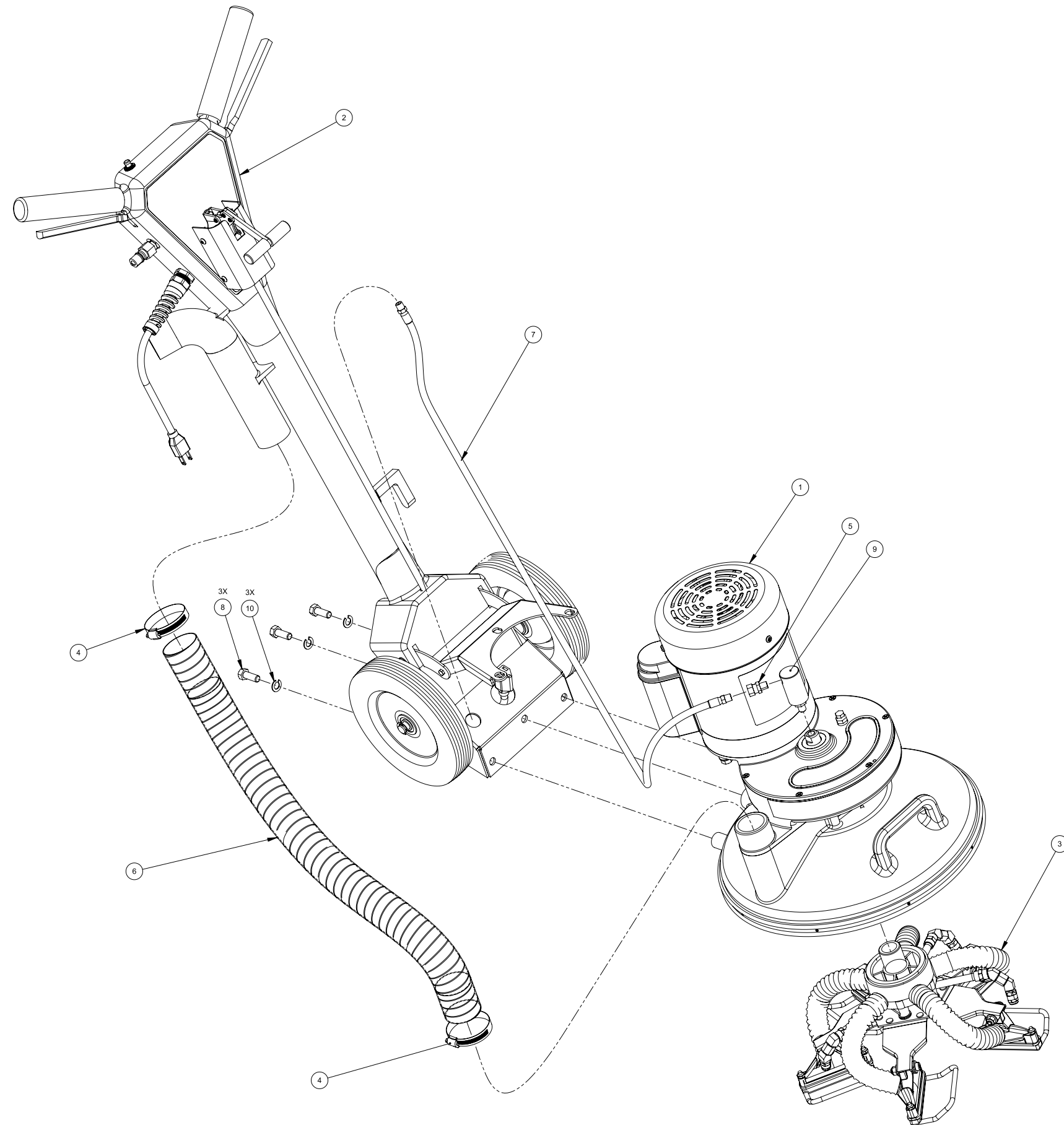

RX-20

Final Assembly Parts List (120 V)

Item	Part Number	Description	Qty
1	604-054-100	Assembly, Base and Drive Train	1
2	604-051-100	Assembly, Upper and Lower Handle	1
3	604-053-100	Assembly, Vacuum Head	1
4	000-033-010	Clamp, Size #32 Hose	2
5	000-052-001	Fitting, Swivel (2M2-2 UFS)	1
6	000-068-040	Hose, 2" Vacuum - Base to Manifold	1
7	000-068-176	Hose, 3/16" X 47" w/ Inserts	1
8	000-143-096	Screw, 3/8"-16UNC X 1.00" Lg. Hex Head	3
9	000-052-294	Union, Rotary	1
10	000-174-057	Washer, 3/8" Lock	3

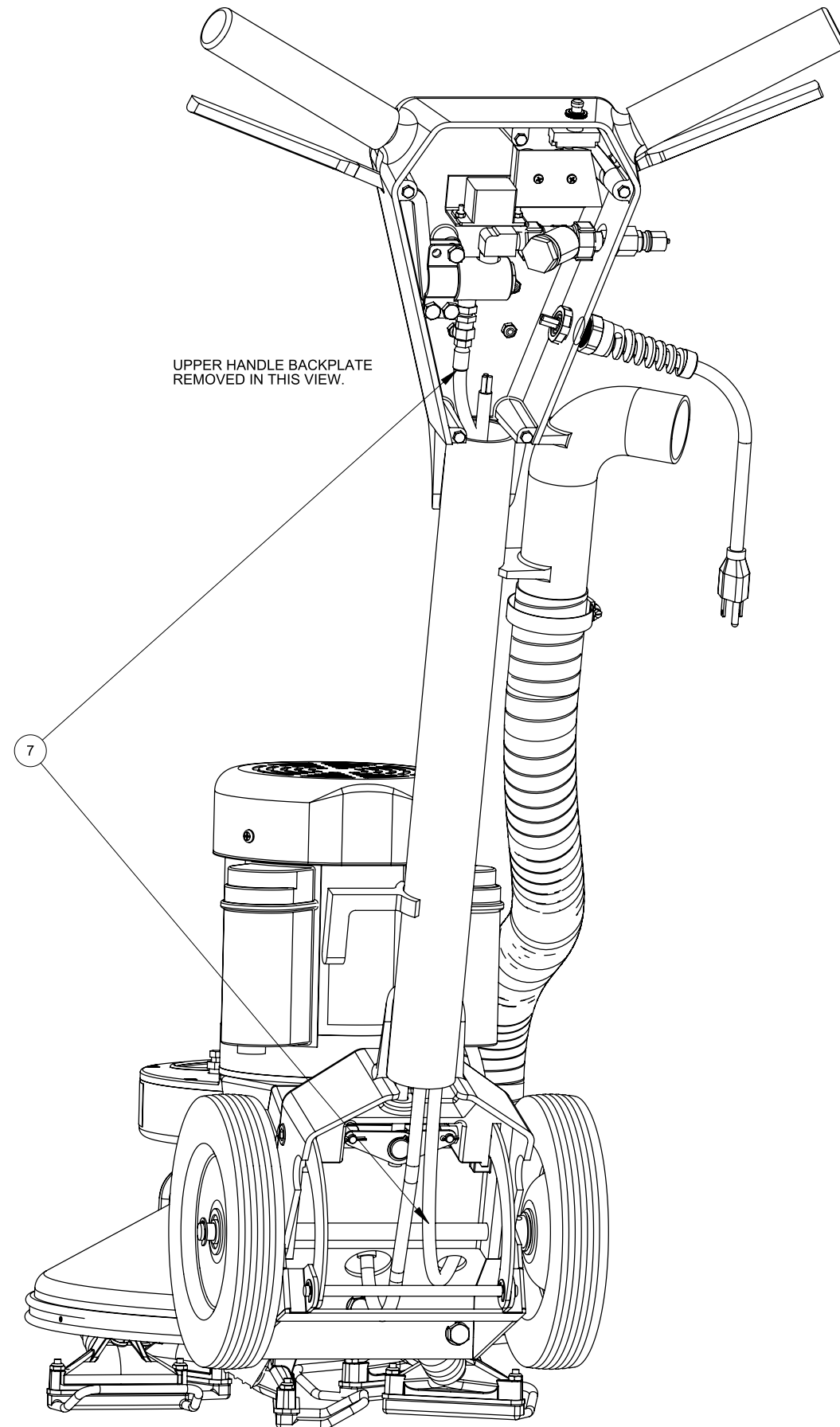
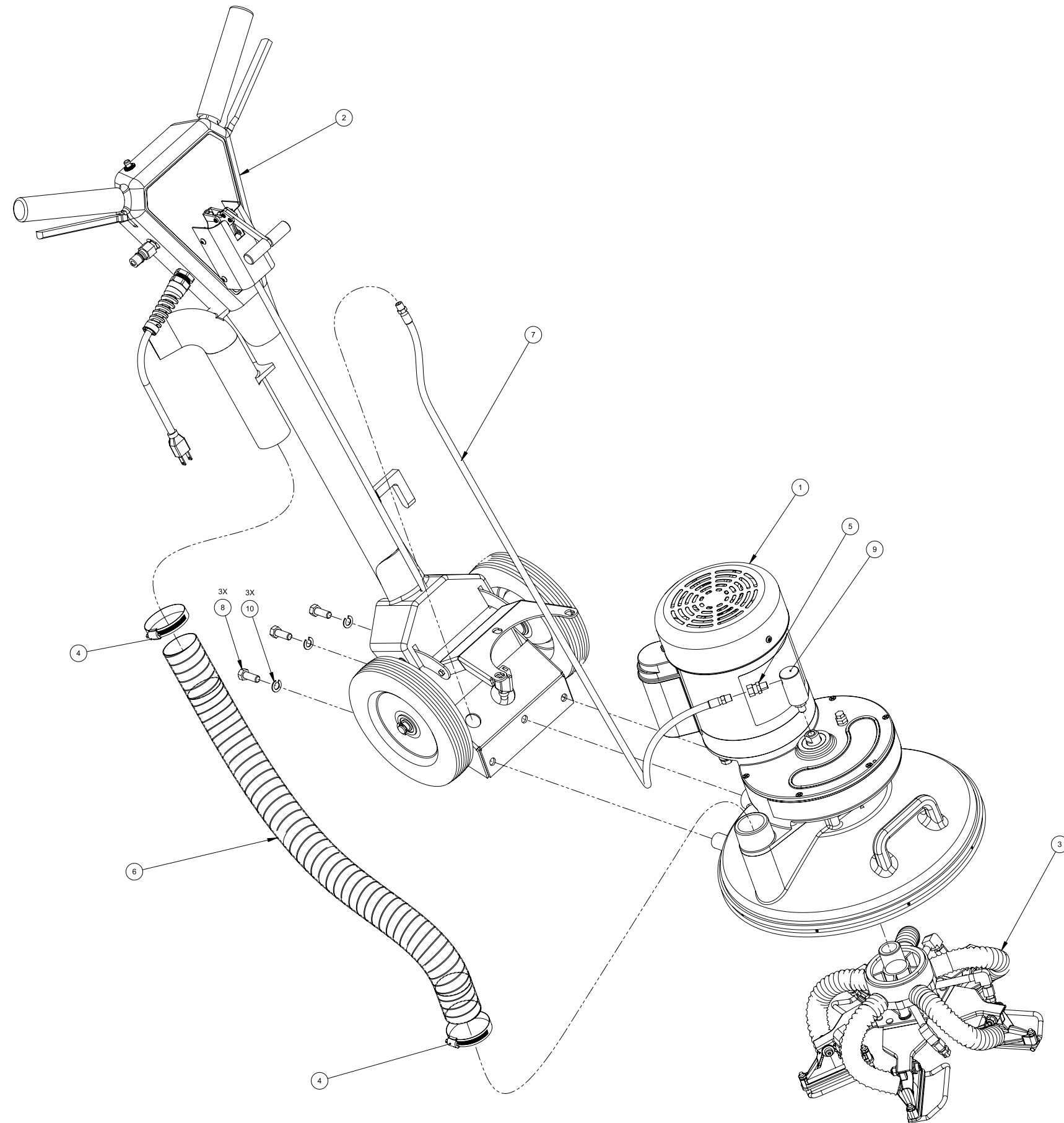

Figure 8-3. Final Assembly (120 V - OS)
604-999-101 Rev. A



RX-20

Final Assembly Parts List (120 V - OS)

Item	Part Number	Description	Qty
1	604-054-100	Assembly, Base and Drive Train 120 V/230V - 60Hz	1
2	604-051-100	Assembly, Upper and Lower Handle	1
3	604-053-101	Assembly, Vacuum Head - Original Style	1
4	000-033-010	Clamp, Size #32 Hose	2
5	000-052-001	Fitting, Swivel (2M2-2 UFS)	1
6	000-068-040	Hose, 2" Vacuum - Base to Manifold	1
7	000-068-176	Hose, 3/16" X 47" w/ Inserts	1
8	000-143-096	Screw, 3/8"-16UNC X 1.00" Lg. Hex Head	3
9	000-052-294	Union, Rotary	1
10	000-174-057	Washer, 3/8" Lock	3

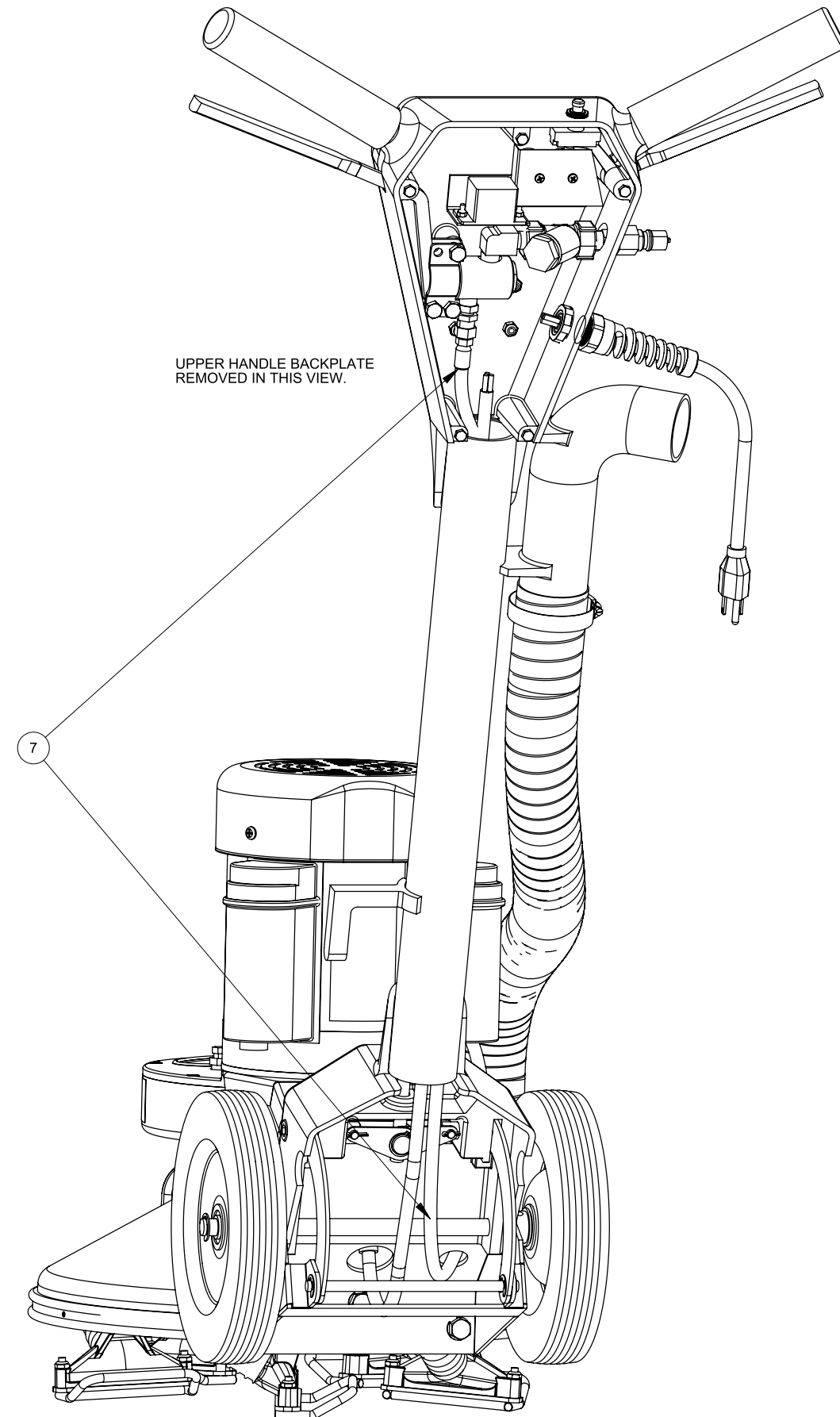
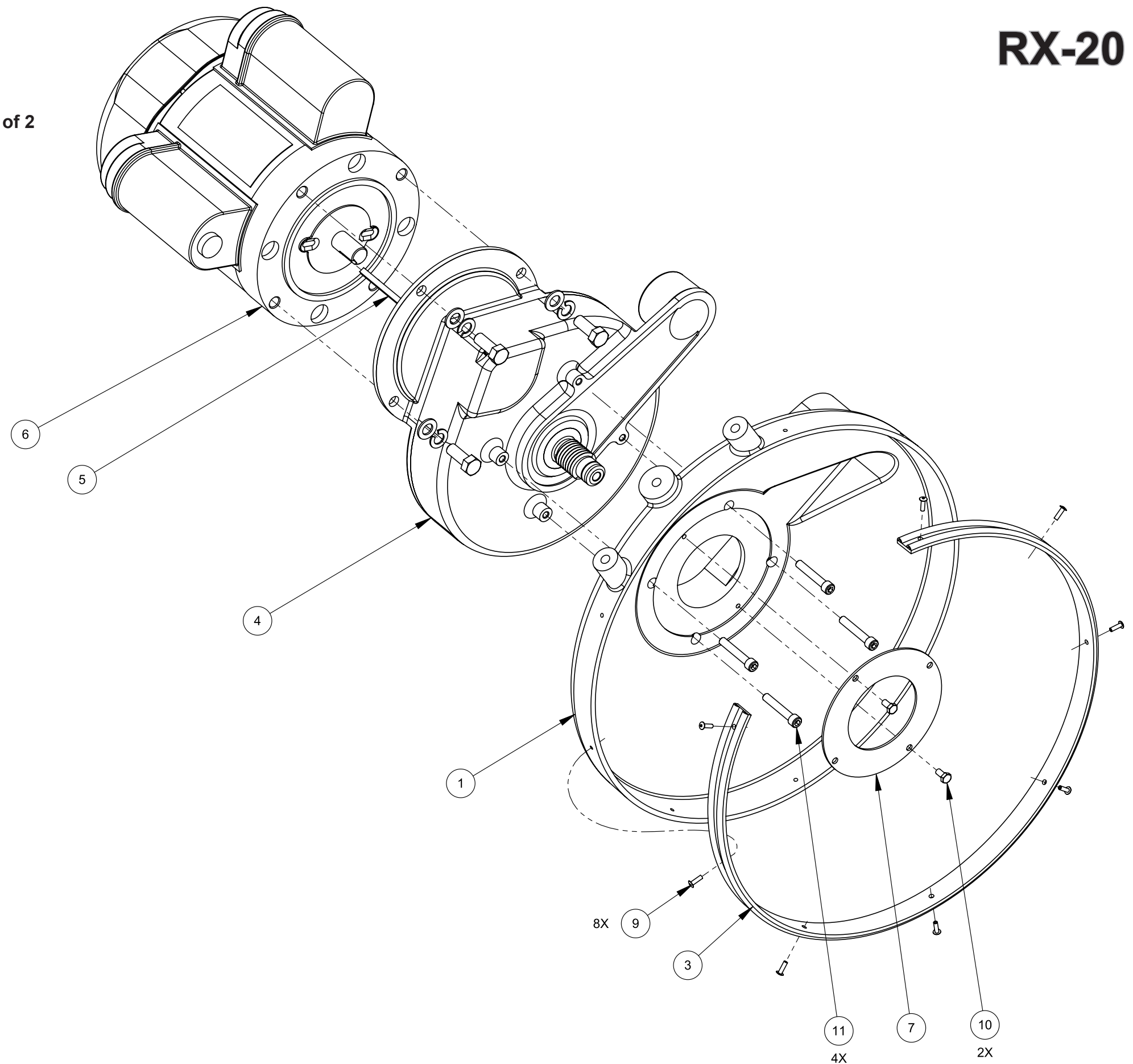
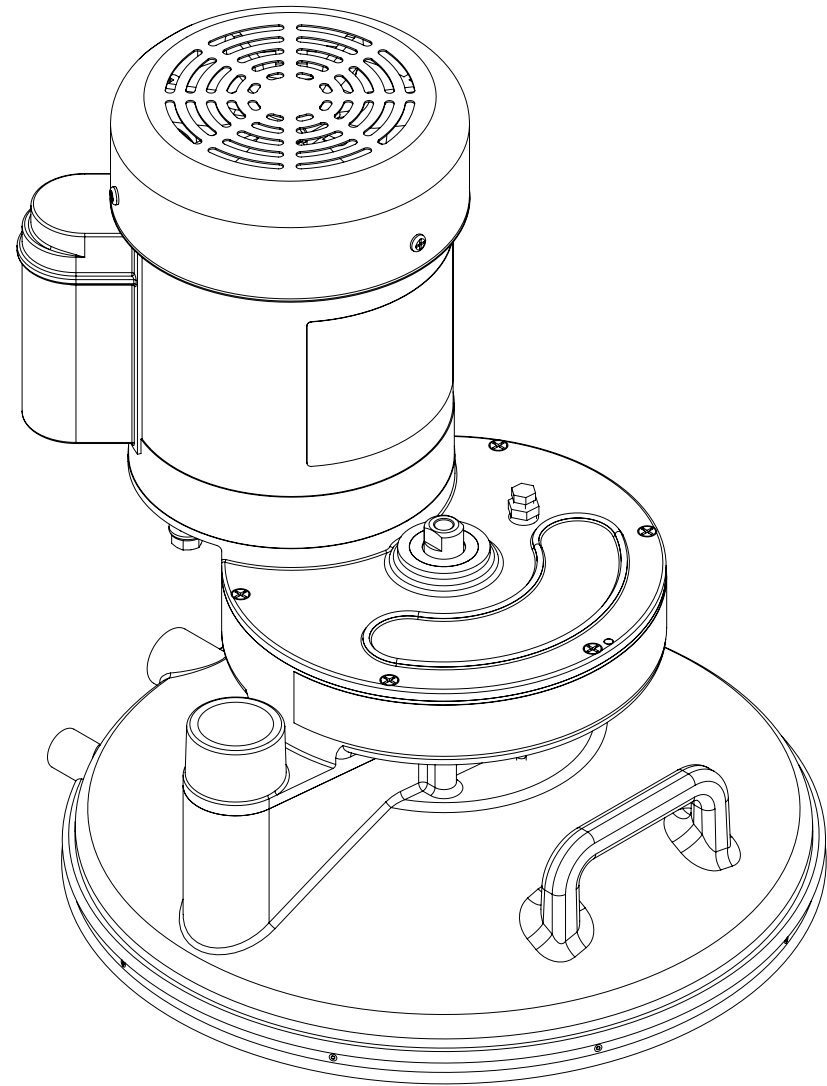

Figure 8-4. Base and Drive Train Assembly (120 V) - View 1 of 2
604-054-100 Rev. F



RX-20

Figure 8-5. Base and Drive Train Assembly (120 V) - View 2 of 2
604-054-100 Rev. F

Base and Drive Train Assembly Parts List (120 V)

Item	Part Number	Description	Qty
1	000-006-009	Base w/ Handle - Coated	1
2	000-052-059	Bushing, 1/4" MPT X 1/8" FPT	1
3	000-131-014	Gasket, Ro to Shroud	1
4	000-059-001	Gear Box - Complete	1
5	000-077-012	Key, 3/16" X 2.5" Lg. Class 2 Fit	1
6	000-091-015	Motor, 1/2Hp TEFC-H/S	1
7	000-105-008	Plate, Seal	1
8	000-106-001	Plug, 1/8" NPT	1
9	000-140-003	Rivet, 1/8" X 5/16" Lg. (Grip Range 0.251" - 0.312")	8
10	000-143-166	Screw, #10-24UNC X 0.375" Lg. Hex Head	2
11	000-143-075	Screw, 1/4"-20UNC X 1.50" Lg. Socket Head	4
12	000-143-096	Screw, 3/8"-16UNC X 1.00" Lg. Hex Head	3
13	000-174-057	Washer, 3/8" Lock	3
14	000-174-055	Washer, Flr Tech Latch Pivot	3

NOTICE

* Use clear silicon to attach Item 4 to Item 1.

** When ordering a replacement motor cover, specify one of the following:

1. For Leeson Motor P/N 117555, order HM P/N 000-041-679
2. For Baldor Motor P/N 35Q351R175G1, order HM P/N 000-041-680
3. For Leeson Motor P/N 113747, order HM P/N 000-041-682

*** Prior to operating the machine, replace the shipping plug (P/N 000-106-001) with the vented plug (P/N 000-106-014). See page 3-1 in this manual for more information.

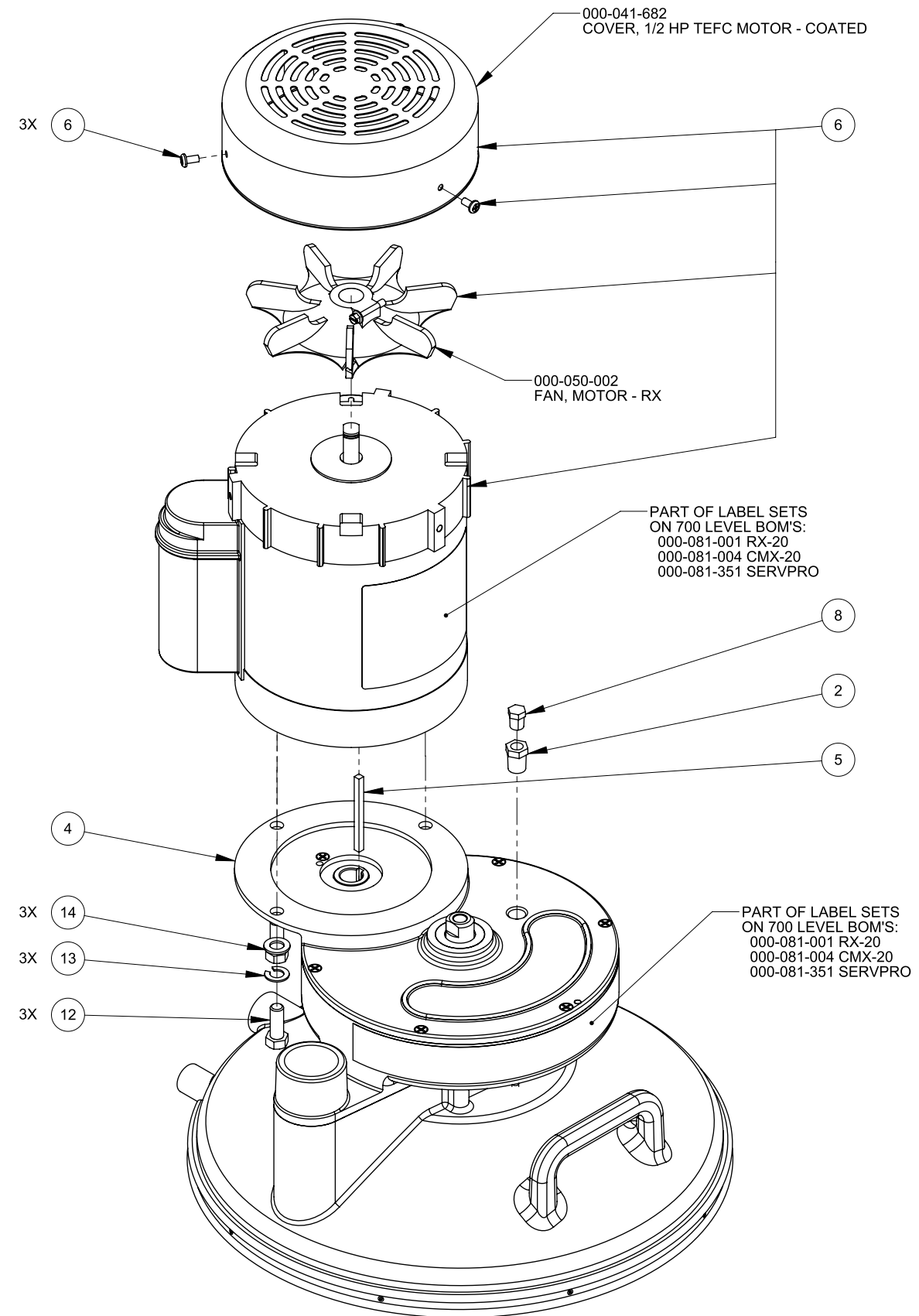
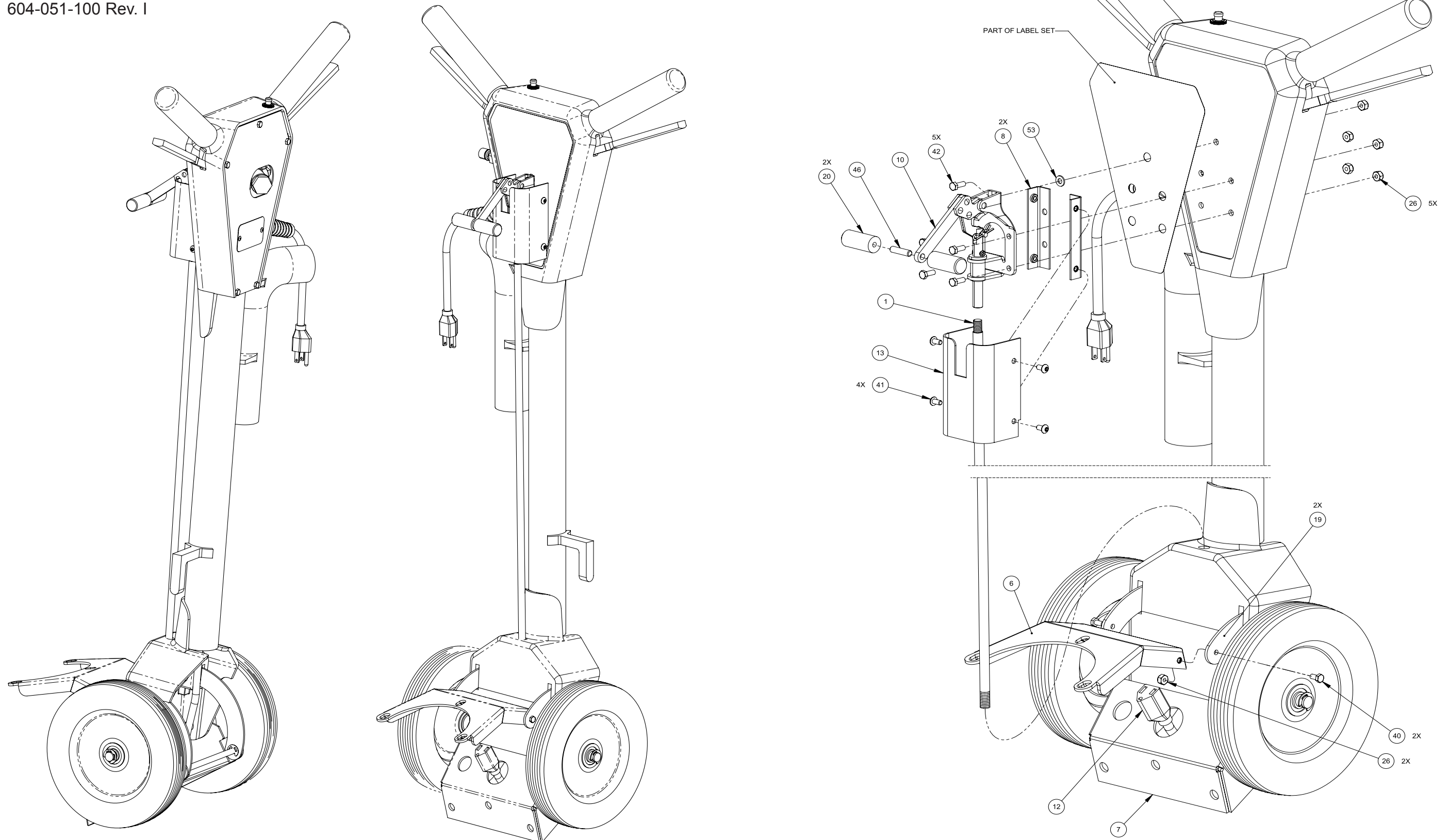
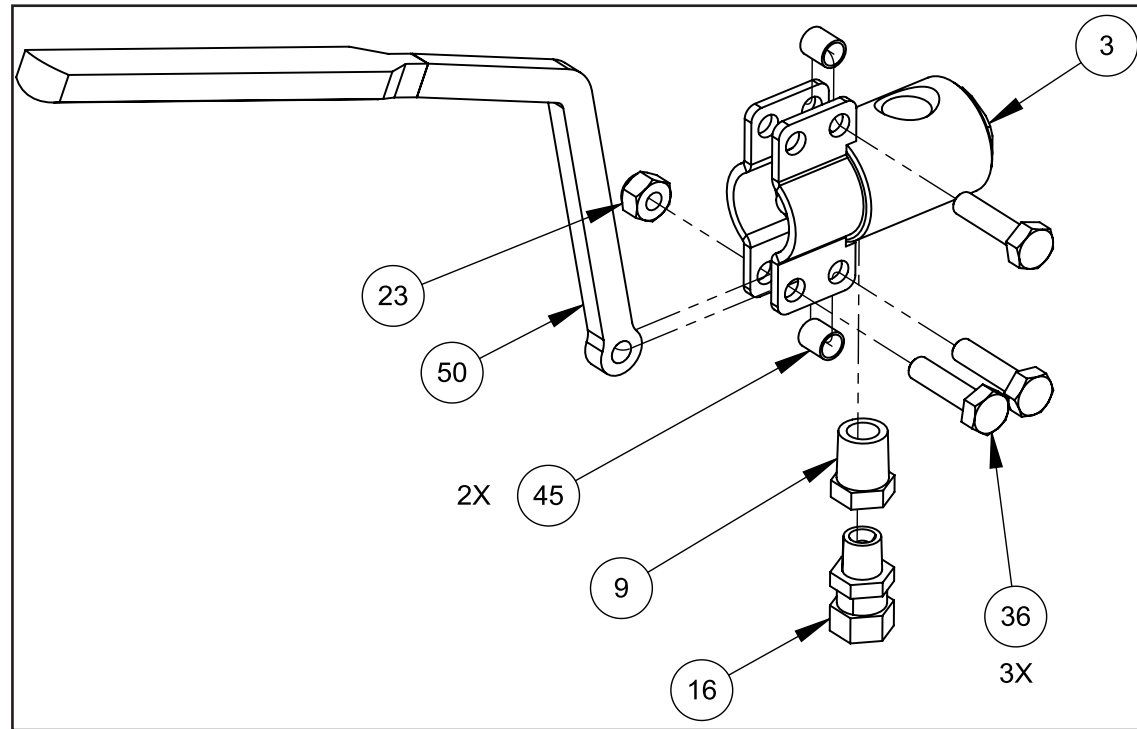

Figure 8-6. Upper and Lower Handle Assembly (120 V) - View 1 of 2
604-051-100 Rev. I



RX-20

Figure 8-7. Upper and Lower Handle Assembly (120 V) - View 2 of 2
604-051-100 Rev. I



Close Up of Solution Valve and Mounting Hardware

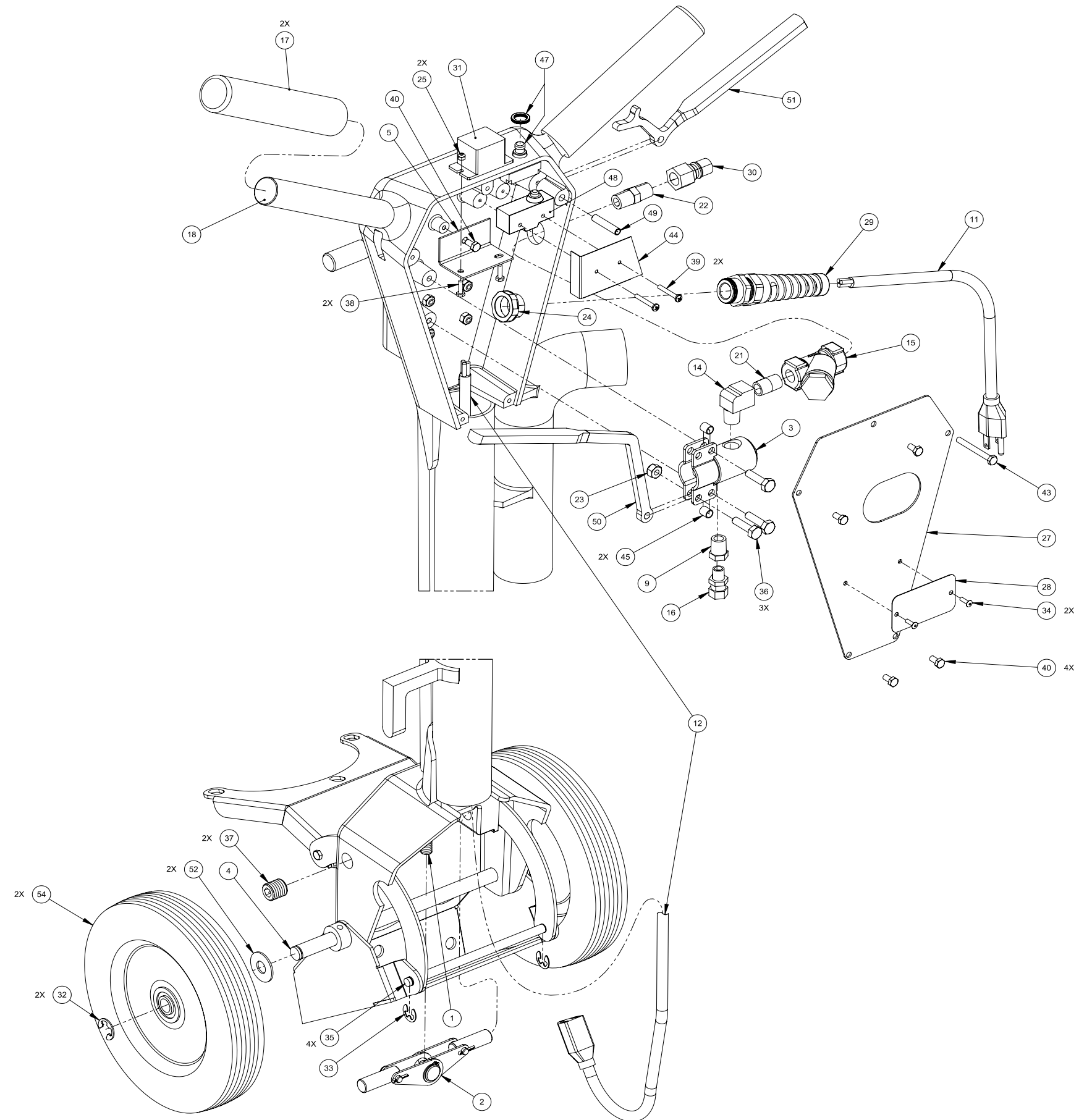

Upper and Lower Handle Assembly Parts List (120 V)

Item	Part Number	Description	Qty	Item	Part Number	Description	Qty
1	000-141-007	Adjusting Rod Assembly	1	28	000-105-018	Plate, Serial I.D.	1
2	604-051-002	Assembly, Handle Locking Linkage	1	29	000-108-012	Protector, Power Cord Relief	1
3	000-169-058	Assembly, Valve, Solution - Standard	1	30	000-052-050	Quick Connect, 440 Male w/ Viton Std	1
4	000-141-004	Axle, Wheel	1	31	000-157-149	Relay, AC Relay 120 V	1
5	000-015-190	Bracket, AC Relay - Fabricated	1	32	000-139-009	Ring, Snap Ring (E-Clip) X 1/2"	2
6	000-015-1207	Bracket, Head Stabilizer, Coated	1	33	000-139-010	Ring, Snap Ring (E-Clip) X 5/16"	4
7	000-015-139	Bracket, Hi Speed Handle to Base - Coated	1	34	000-140-003	Rivet, 1/8" X 5/16" Lg. (Grip Range 0.251" - 0.312")	2
8	000-015-552	Bracket, Linkage Clamp Cover - Coated	2	35	000-141-031	Rod, Handle Arc	1
9	000-052-059	Bushing, 1/4" MPT X 1/8" FPT	1	36	000-143-002	Screw, 1/4"-20UNC X 1.00" Lg. Hex Head	3
10	000-033-114	Clamp, Linkage - Modified	1	37	000-143-609	Screw, 5/8-18UNC X 0.625" Lg. Socket Hd Set	2
11	000-178-004	Cord, Power 14/3 Gray X 50 ft w/ Male	1	38	000-143-575	Screw, #6-32UNC X 0.50" Lg. Hex Head	2
12	000-178-039	Cord, Power - 14/3 Gray X 42" w/ Female	1	39	000-143-048	Screw, #10-24UNC X 0.25" Lg. Pan Head Phillips	2
13	000-041-352	Cover, Linkage Clamp - Coated	1	40	000-143-166	Screw, #10-24UNC X 0.375" Lg. Hex Head	7
14	000-052-085	Elbow, 1/4" NPT Street	1	41	000-143-107	Screw, #10-24UNC X 0.375" Lg. Button Head Socket	4
15	000-049-033	Filter, In-Line, "Y"	1	42	000-143-126	Screw, #10-24UNC X 0.50" Lg. Hex Head	5
16	000-052-001	Fitting, Swivel (2M2-2 UFS)	1	43	000-143-065	Screw, #10-24UNC X 1.75" Lg. Hex Head	1
17	000-061-004	Grip, Foam - Handle	2	44	000-108-014	Shield, Micro Switch	1
18	000-061-017	Handle - Coated	1	45	000-154-001	Spacer, 1/4" X 5/16" - S/S Solution Valve	2
19	000-107-096	Handle, Arc	2	46	000-156-031	Stud, 1/4"-20UNC X 1.00" Lg.	1
20	000-061-030	Handle, "T"	2	47	000-157-151	Switch, Chrome, Momentary	1
21	000-052-072	Nipple, 1/4" NPT Close	1	48	000-157-032	Switch, Micro	1
22	000-052-071	Nipple, 1/4" NPT Hex	1	49	000-107-103	Trigger Pivot	1
23	000-094-009	Nut, 1/4"-20UNC Nylock	1	50	000-167-009-07	Trigger, Handle - LH	1
24	000-094-036	Nut, 1/2" NPT Pipe Plastic	1	51	000-167-010-07	Trigger, Handle - RH	1
25	000-094-063	Nut, #6-32UNC Nylock	2	52	000-174-006	Washer, 7/16" Flat	2
26	000-094-034	Nut, #10-24UNC Nylock	7	53	000-174-001	Washer, #10 Flat	1
27	000-041-013	Plate, Back Handle - Coated	1	54	000-177-001	Wheel, 8"	2

RX-20

Figure 8-8. Vacuum Head Assembly
604-053-100 Rev. C

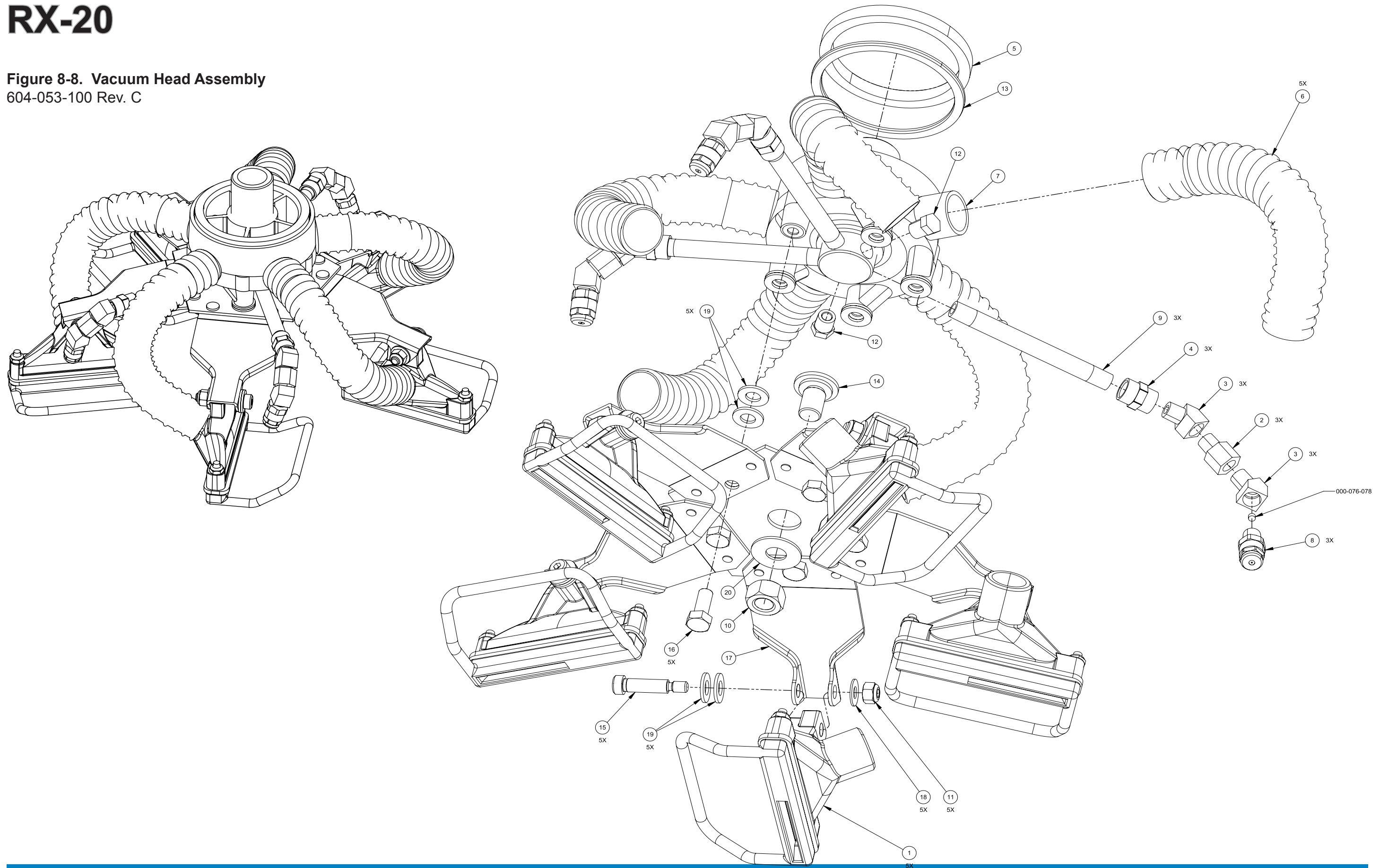

Vacuum Head Assembly Parts List

Item	Part Number	Description	Qty
1	000-064-012	Assembly, Vacuum Shoe and Skid	5
2	000-052-427	Bushing, 1/8" NPT X 1/8" FPT	3
3	000-052-078	Elbow, 1/8" NPT X 45 Degree Street	6
4	000-052-440	Fitting, 1/8" NPT Brass Coupling - Machined	3
5	000-057-047	Gasket, Felt	1
6	000-068-174	Hose, 1" Vacuum - Gray	5
7	000-107-020*	Hub, Vacuum, Brass, 5 Ports, Dual Lead Thread	1
8	000-076-076	Jet, Full Cone 1/8"	3
9	000-052-515	Nipple, 1/8" NPT X 4" Lg.	3
10	000-094-019	Nut, 1/2"-13UNC Hex	1
11	000-094-009	Nut, 1/4"-20UNC Nylock	5
12	000-106-001	Plug, 1/8" NPT	2
13	000-139-001	Ring Plastic 2007	1
14	000-143-045	Screw, 1/2" Modified Star Removal Bolt	1
15	000-143-162	Screw, 5/16" X 1" Lg. Stripper - 1/4"-20UNC	5
16	000-143-012	Screw, 5/16"-18UNC X 3/4" Lg.	5
17	000-107-089	Star, Assembly	1
18	000-174-003	Washer, 1/4" Flat	5
19	000-174-049	Washer, 5/16" Flat	20
20	000-174-006	Washer, 7/16" Flat	1

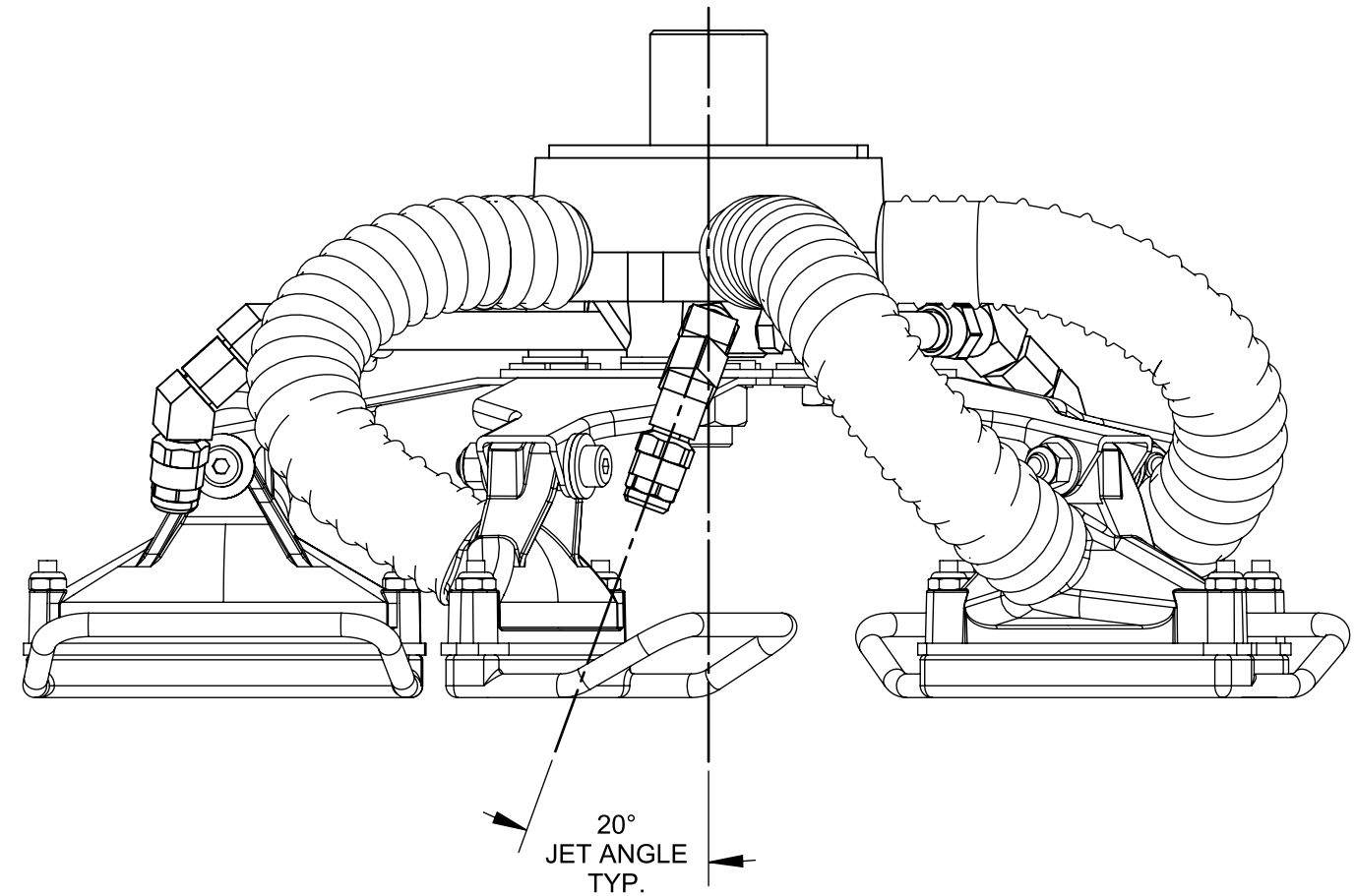

SOME PARTS NOT SHOWN FOR CLARITY.

NOTICE

*When replacing 000-107-020 Hub, order 000-107-0201 which includes the 000-139-001 Ring already inserted in to 000-107-020.

RX-20

Figure 8-9. Vacuum Head Assembly OS
604-053-101 Rev. A

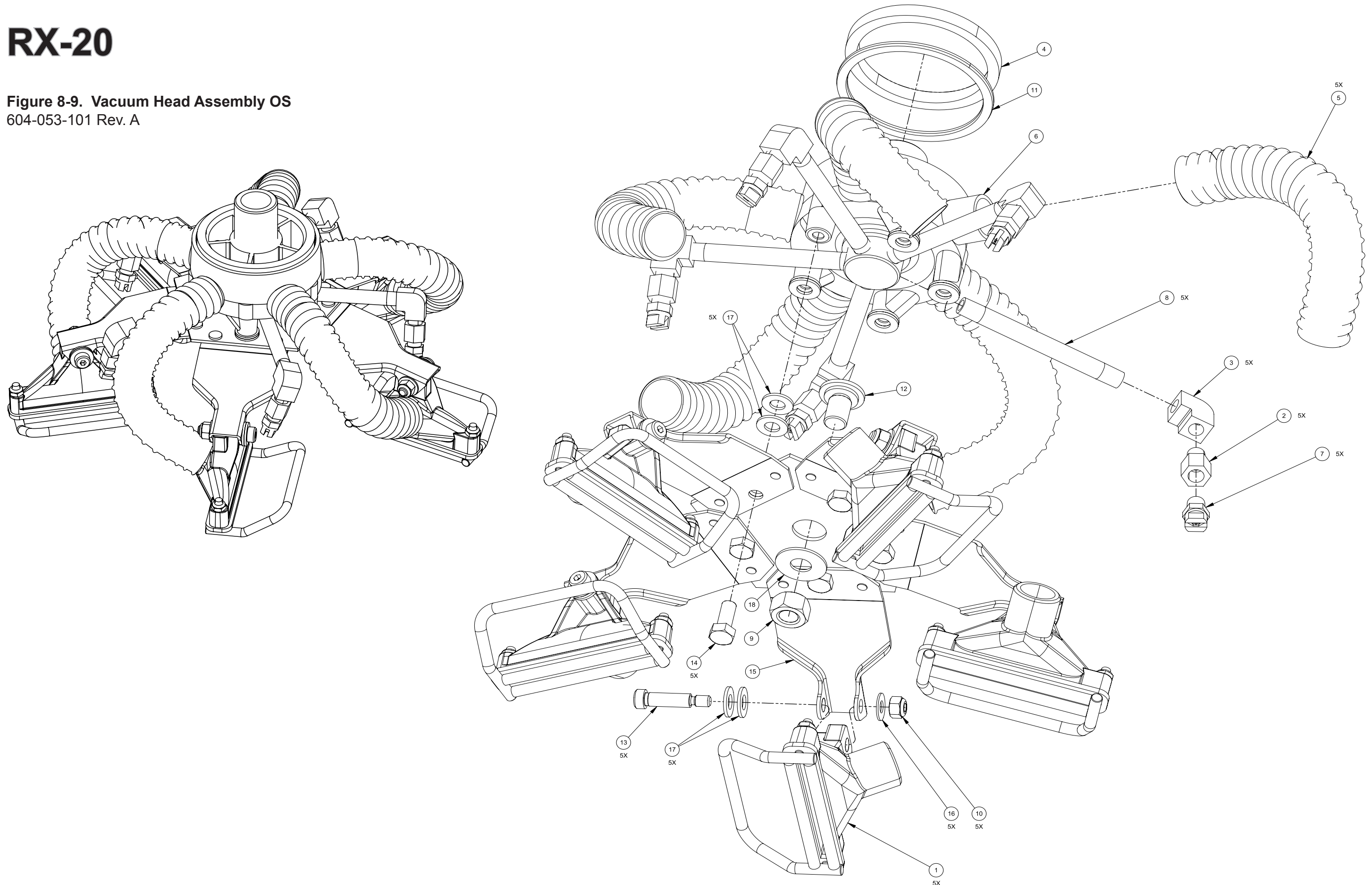

Vacuum Head Assembly OS Parts List

Item	Part Number	Description	Qty
1	000-064-012-OS	Assembly, Vacuum Shoe and Skid OS	5
2	000-052-427	Bushing, 1/8" NPT X 1/8" FPT	5
3	000-052-089	Elbow, 1/8" NPT Female	5
4	000-057-047	Gasket, Felt	1
5	000-068-174	Hose, 1" Vacuum - Gray	5
6	000-107-020*	Hub, Vacuum, Brass, 5 Ports, Dual Lead Thread	1
7	000-076-037	Jet H1/8VV 80015 S/S	5
8	000-052-080	Nipple, 1/8" NPT X 4" Lg.	5
9	000-094-019	Nut, 1/2"-13UNC Hex	1
10	000-094-009	Nut, 1/4"-20UNC Nylock	5
11	000-139-001	Ring Plastic *	1
12	000-143-045	Screw, 1/2" Modified Star Removal Bolt	1
13	000-143-162	Screw, 5/16" X 1" Lg. Stripper - 1/4"-20UNC	5
14	000-143-012	Screw, 5/16"-18UNC X 3/4" Lg.	5
15	000-107-089	Assembly, Star	1
16	000-174-003	Washer, 1/4" Flat	5
17	000-174-049	Washer, 5/16" Flat	20
18	000-174-006	Washer, 7/16" Flat	1

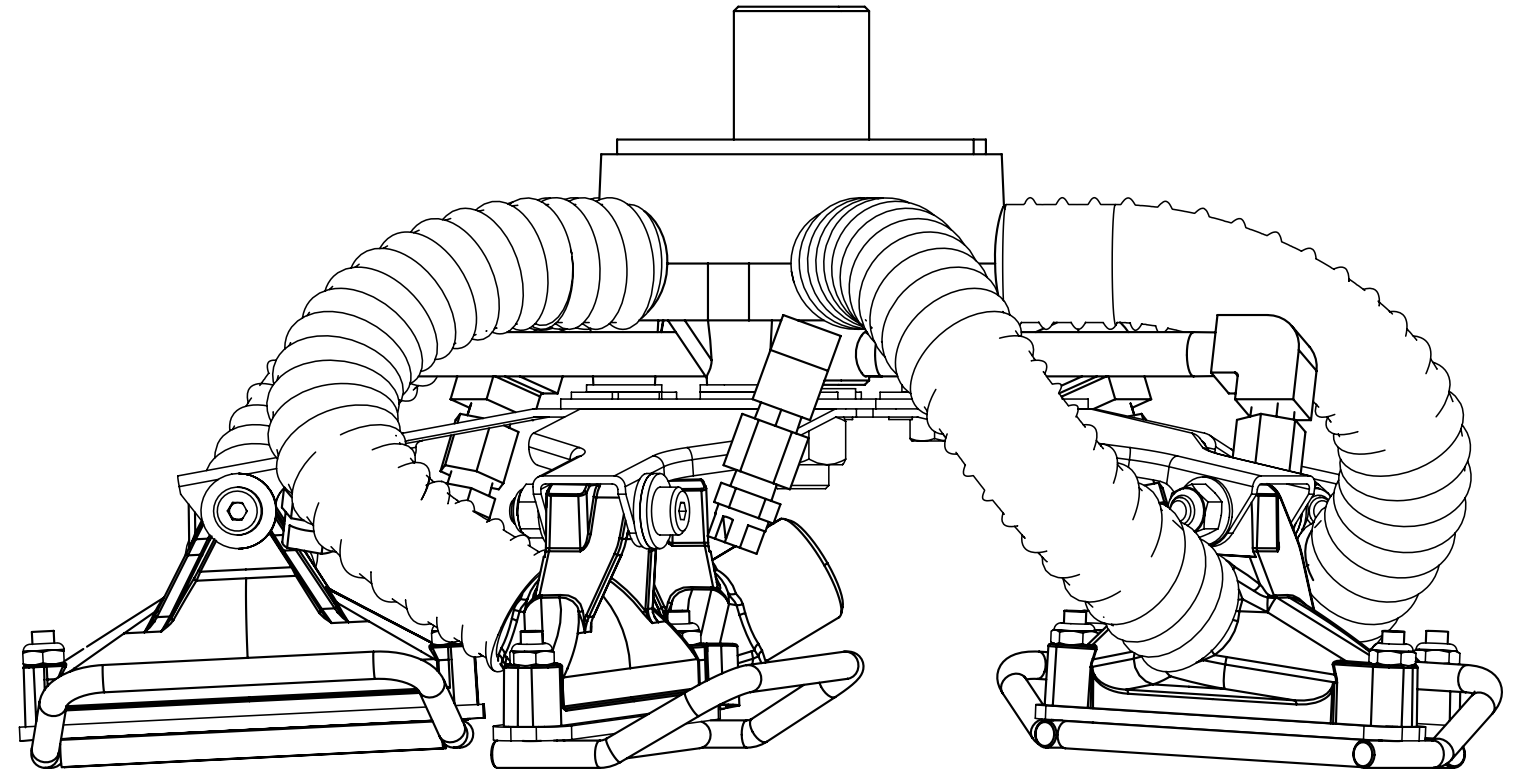

NOTICE

*When replacing 000-107-020 Hub, order 000-107-0201 which includes the 000-139-001 Ring already inserted in to 000-107-020.

RX-20

Figure 8-10. Handle Locking Linkage Assembly
604-051-002 Rev. B

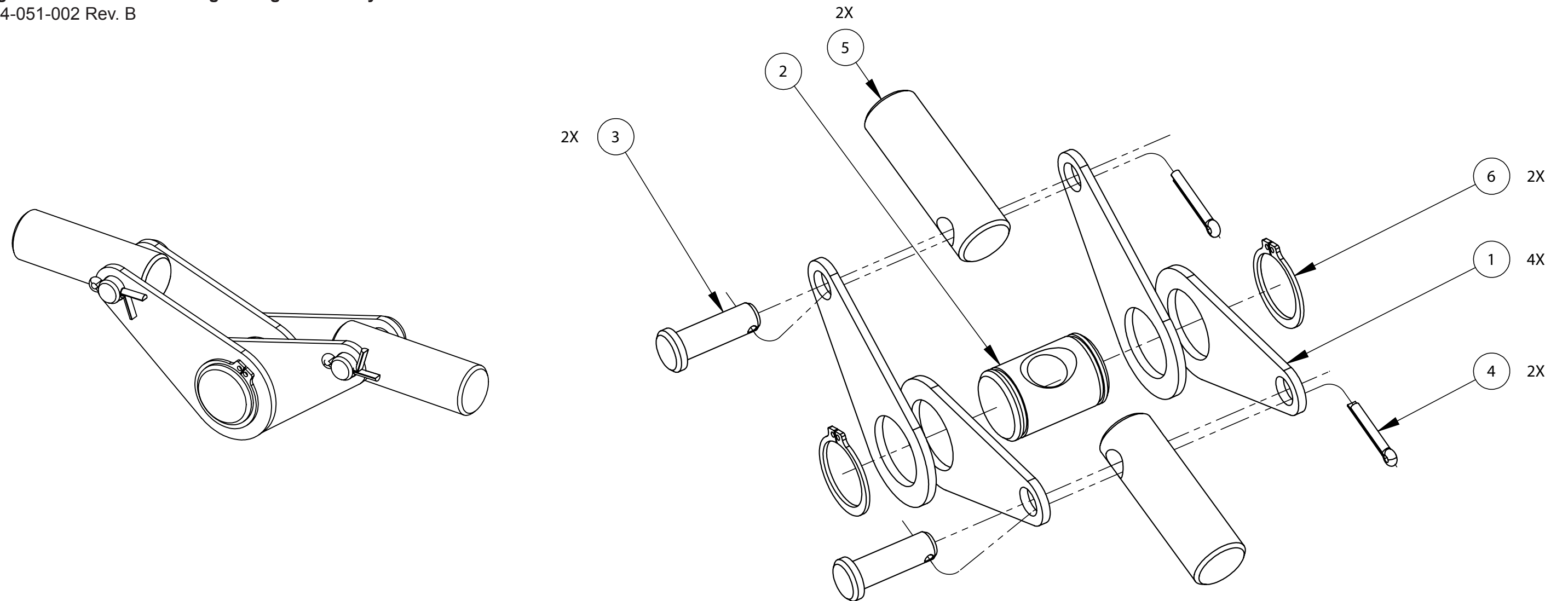

Handle Locking Linkage Assembly Parts List

Item	Part Number	Description	Qty
1	000-107-097	Link	4
2	000-094-030-07	Nut, Adjusting, Linkage - Handle Locking	1
3	000-103-012	Pin, 1/4" X 7/8" - Clevis	2
4	000-103-013	Pin, Cotter	2
5	000-107-256	Plunger, Handle Latching	2
6	000-139-006	Ring, 5/8" Snap	2

Figure 8-11. Gear Box
000-059-001 Rev. C

Gear Box Assembly Parts List

Item	Part Number	Description	Qty
1	000-042-007	Body, Gear Box	1
2	000-041-078	Cover, Gear Box	1
3	000-059-004	Gear, Spur - Gear Box Driven Gear	1
4	000-150-002	Output Shaft, Spur, Double Lead Thread	1
5	000-059-006	Gear/Input Shaft Assembly	1
6	000-008-007	Bearing, Spur - Gear Box	1
7	000-008-008	Bearing, Spur, Race - Gear Box	2
8	000-008-009	Bearing, Spur - Gear Box	1
9	000-008-012	Bearing, Spur - Gear Box	1
10	000-008-041	Bearing, Spur - Gear Box	1
11	000-097-009	O-Ring, Cast Gear Box	1
12	000-103-023	Pin, Dowel - 3/16" X 3/4"	2
13	000-147-018	Seal, Spur Gear Box	1
14	000-147-019	Seal, Spur Gear Box	1
15	000-147-015	Seal, Thread Shaft	1
16	000-143-157	Screw, #10-24UNC X 1.00" Lg. Flat Head	1
17	000-143-114	Screw, #10-24UNC X 0.50" Lg. Flat Head Phillips	5

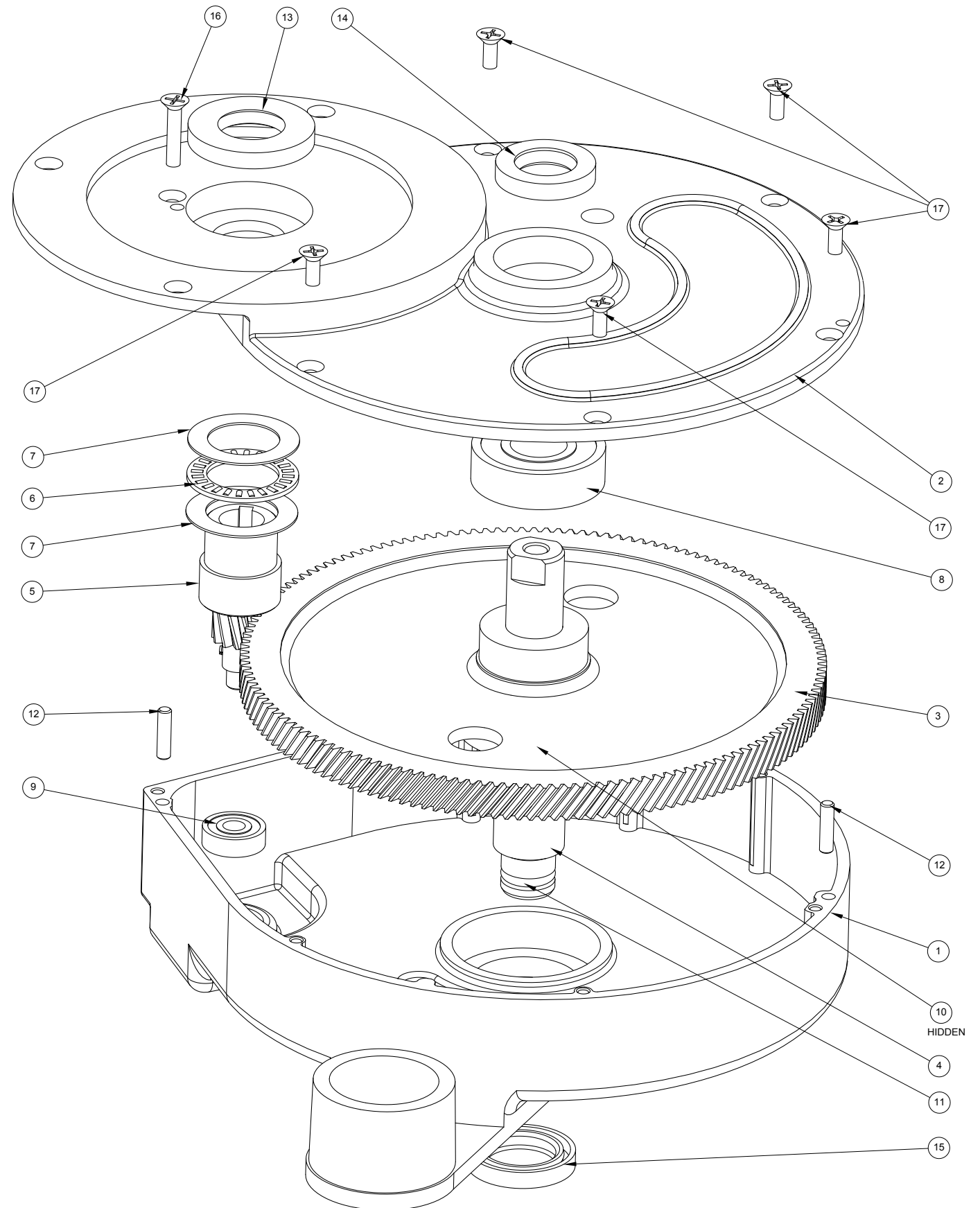
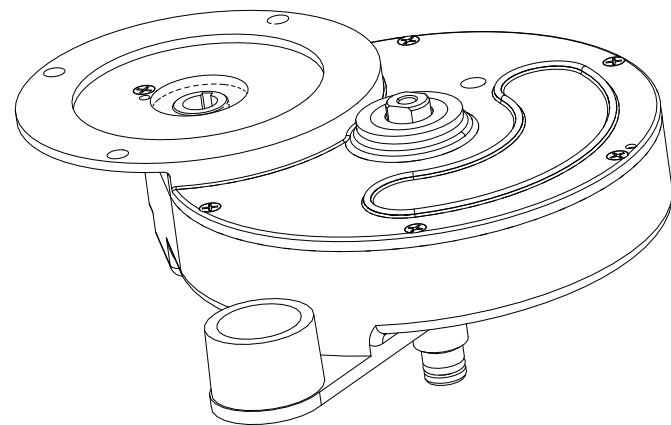

RX-20

Figure 8-12. Vacuum Shoe and Skid Assembly
000-064-012 Rev. B

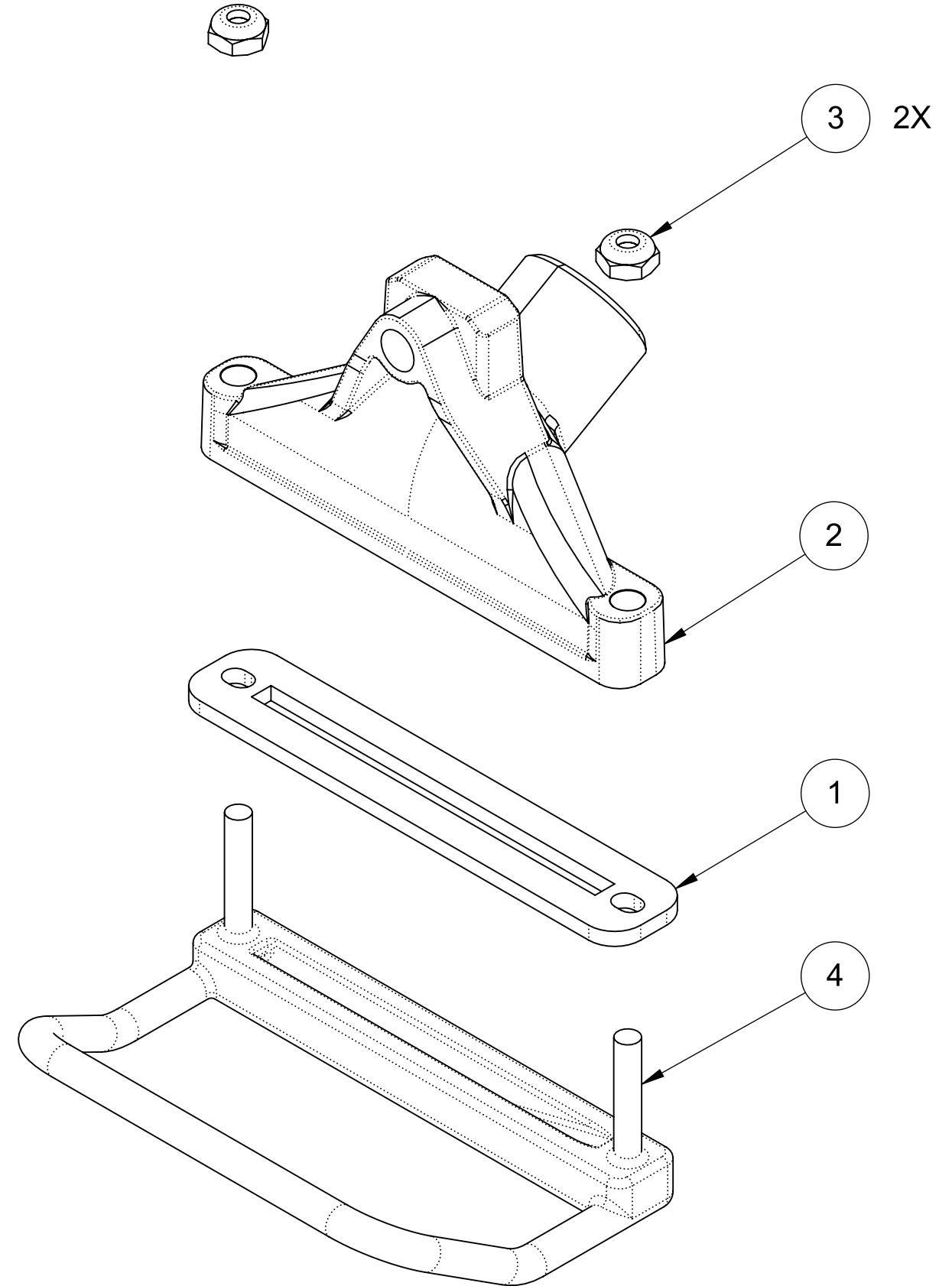
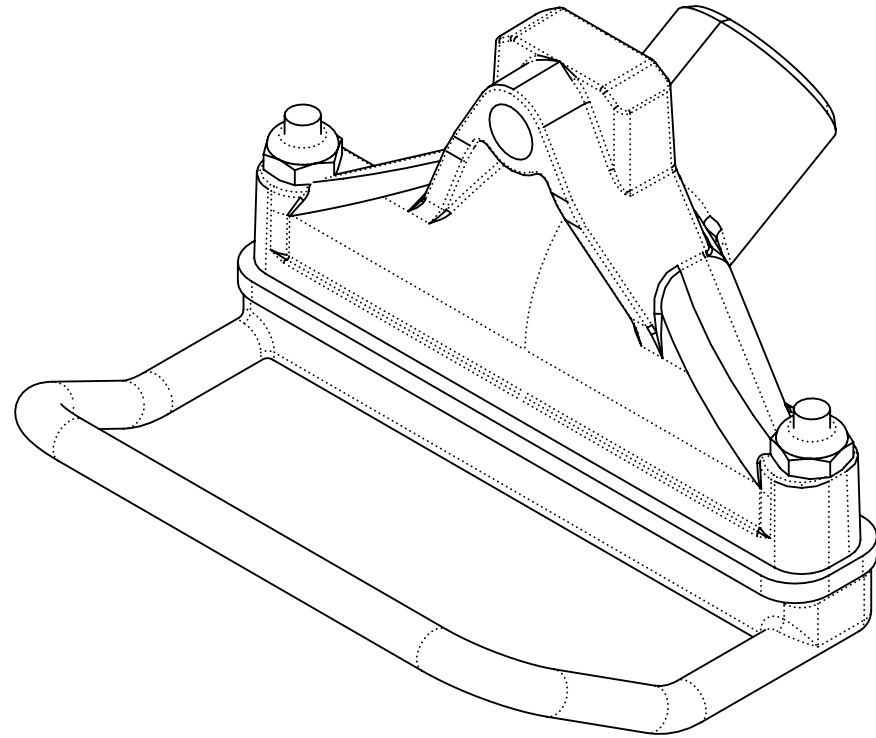

Vacuum Shoe and Skid Assembly Parts List

Item	Part Number	Description	Qty
1	000-057-048	Gasket, Vacuum Head	1
2	000-064-030	Head, Shoe, 4" Cast, One Piece	1
3	000-094-058	Nut, #10-32UNF Nylock	2
4	000-107-245	Skid, Cast	1

Figure 8-13. Vacuum Shoe and Skid Assembly OS
000-064-012-OS Rev. B

Vacuum Shoe and Skid Assembly OS Parts List

Item	Part Number	Description	Qty
1	000-057-048	Gasket, Vacuum Head	1
2	000-064-030	Head, Shoe, 4" Cast, One Piece	1
3	000-094-058	Nut, #10-32UNF Nylock	2
4	000-107-095	Skid, Wire Frame	1

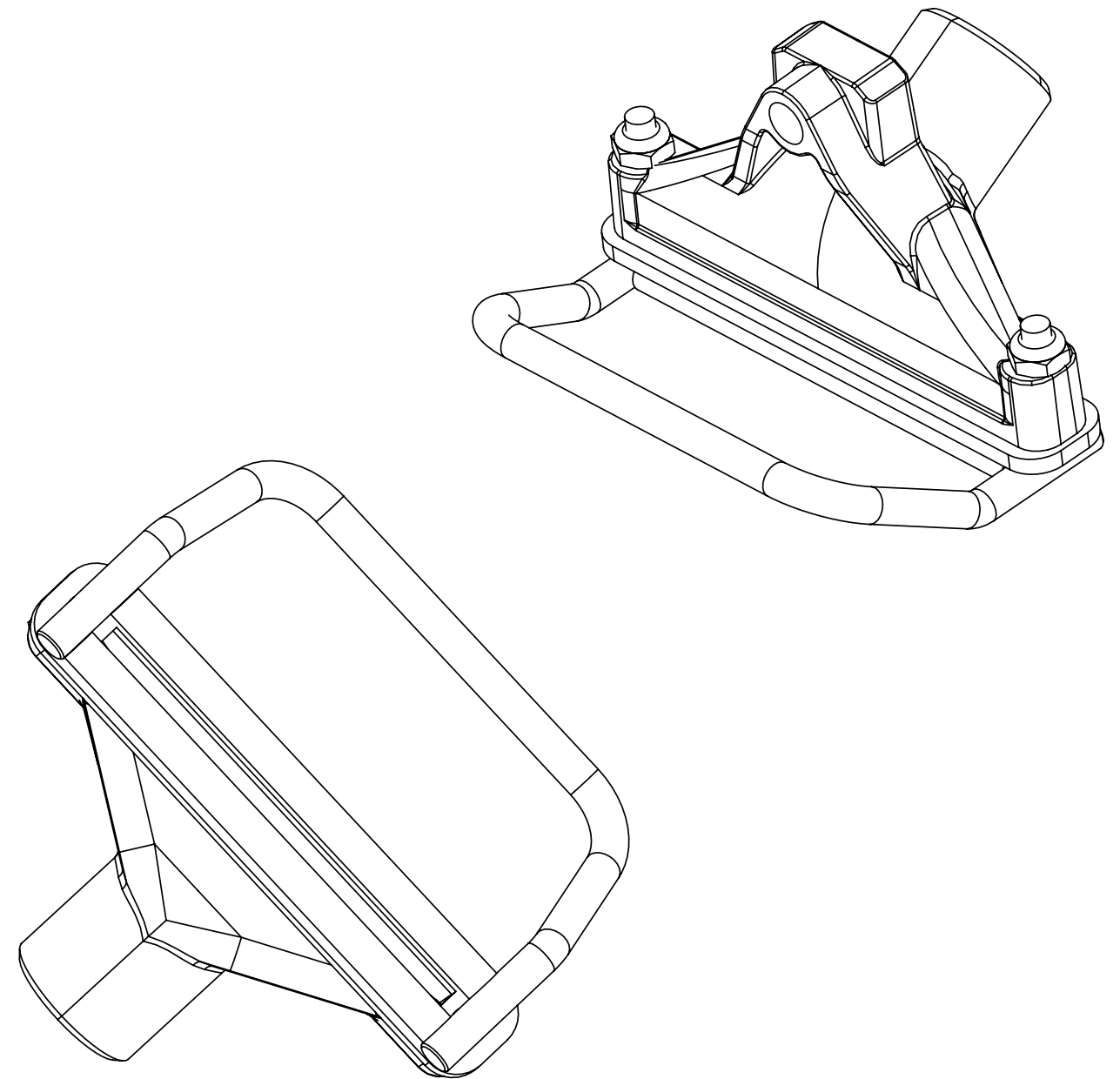
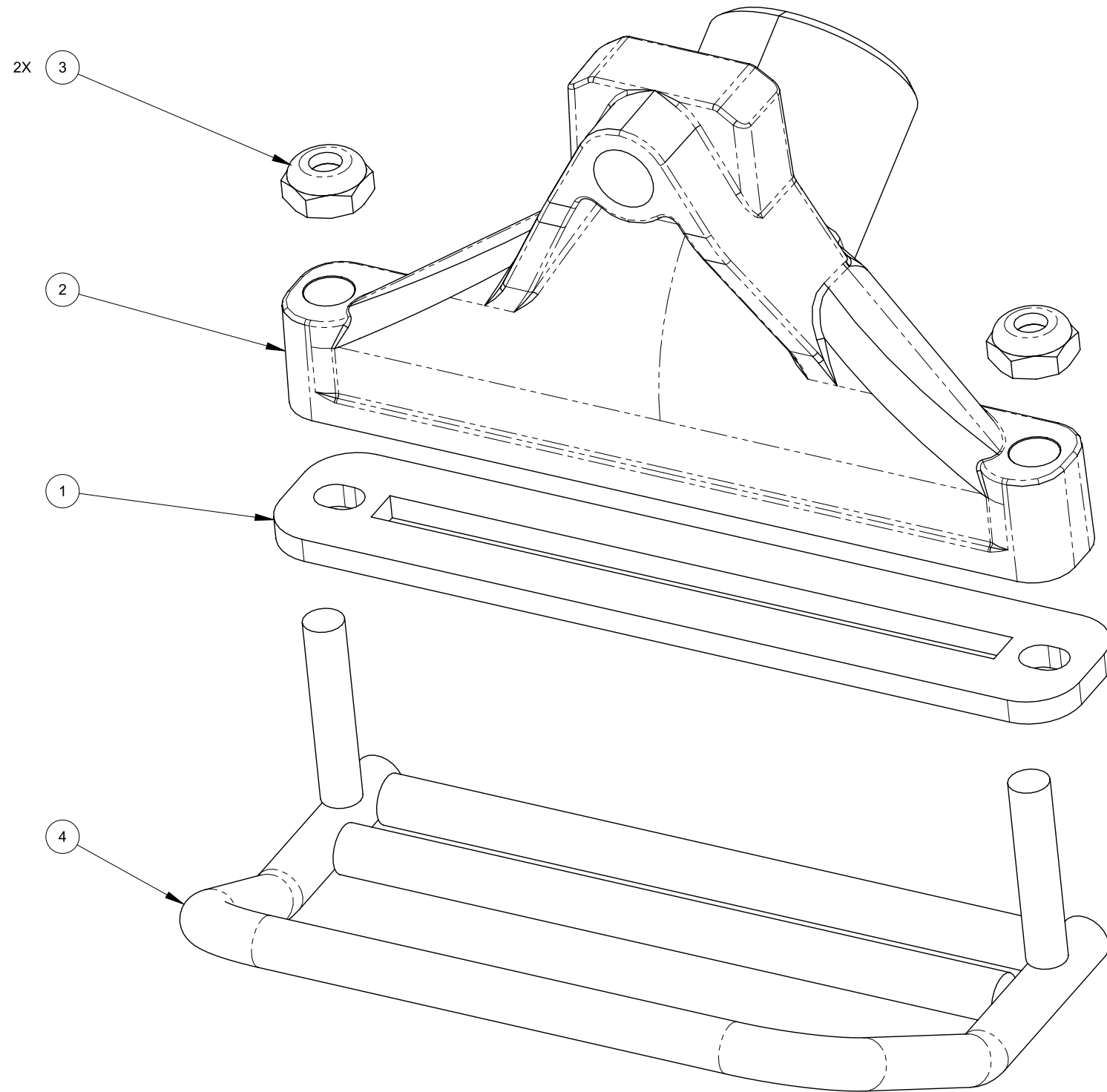

RX-20

Figure 8-14. Solution Valve Assembly
000-169-058 Rev. C

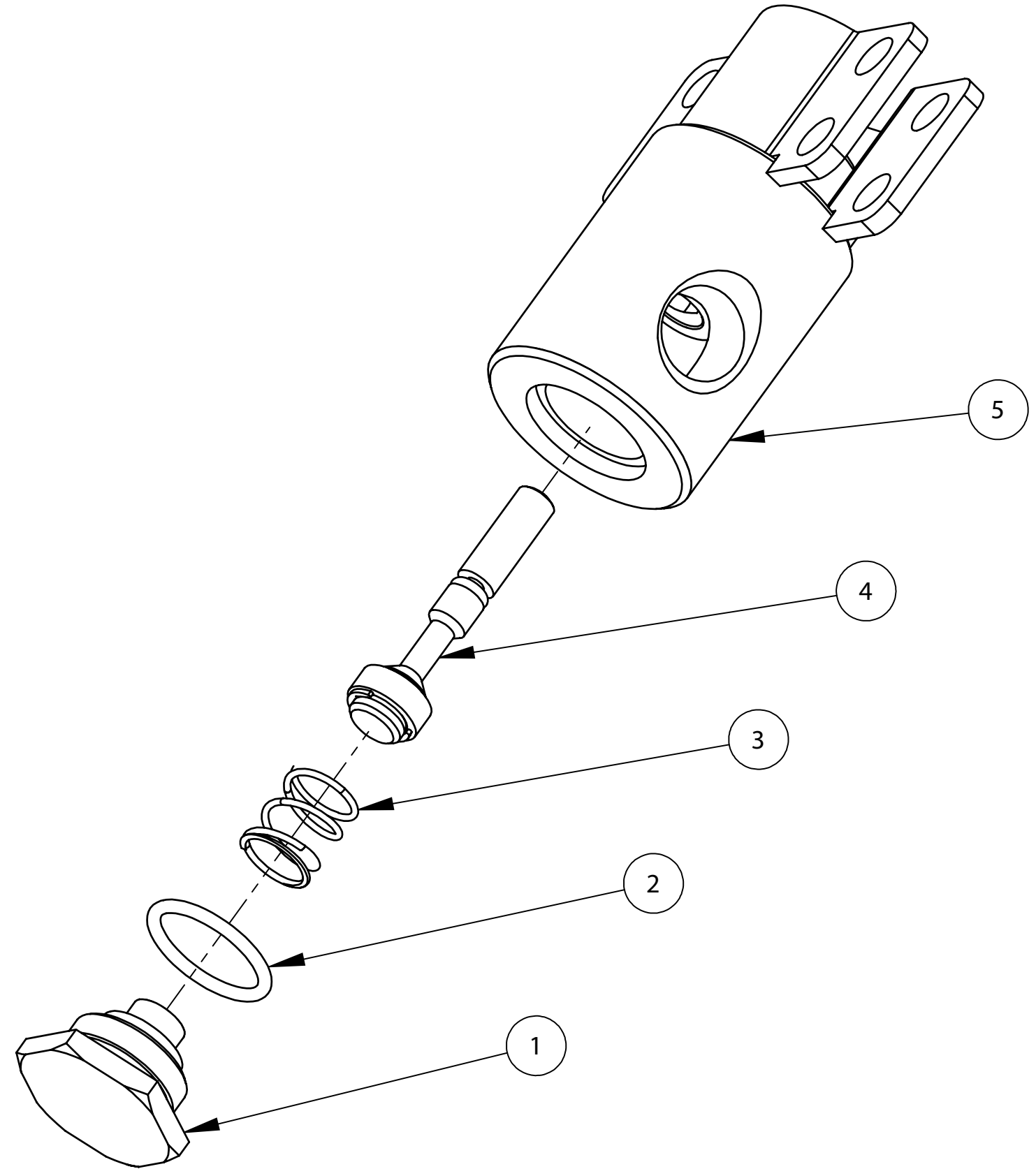
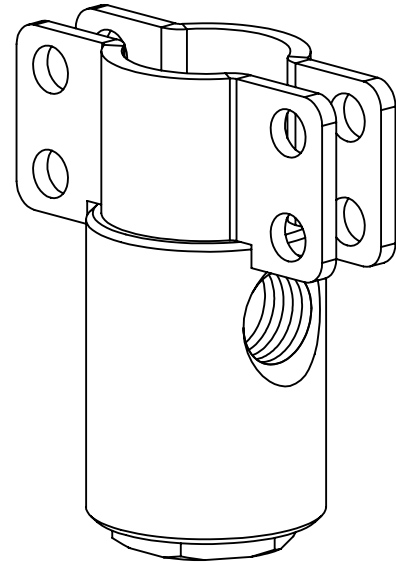

Solution Valve Assembly Parts List

Item	Part Number	Description	Qty
1	000-027-001	Cap, Solution Valve - Brass	1
2	000-097-011	O-Ring, 5/8" X 1/16"	1
3	000-155-003	Spring, Solution Valve	1
4	600-012-002	Assembly, Valve Stem - Standard	1
5	600-012-001	Valve, Body - Welded	1

Figure 8-15. Valve Stem Assembly
600-012-002 Rev. A

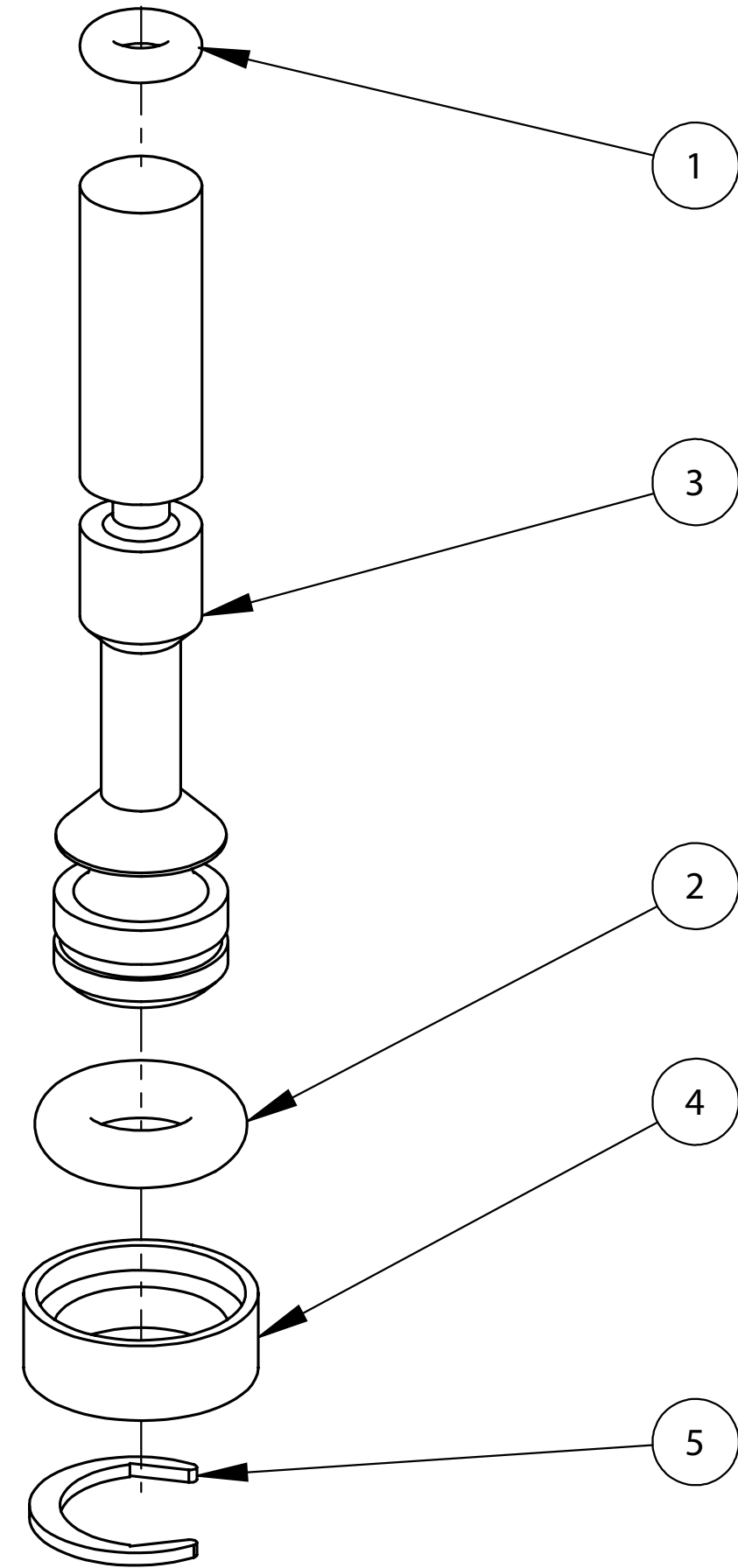
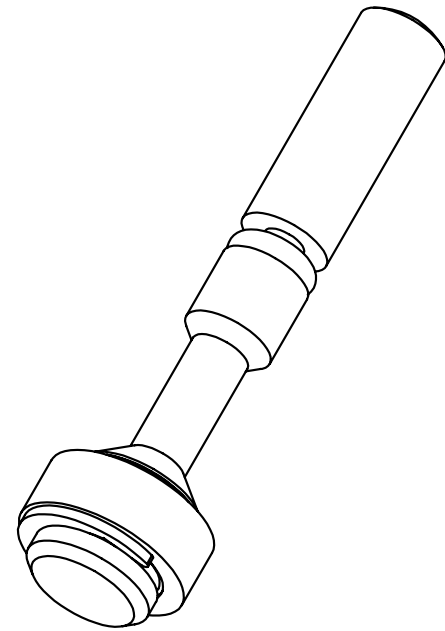

Valve Stem Assembly Parts List

Item	Part Number	Description	Qty
1	000-097-022	O-Ring, 3/32"X1/16" W	1
2	000-097-010	O-Ring, Valve Plunger- Large	1
3	000-107-129	Plunger, Solution Valve	1
4	000-139-003	Ring, Solution Valve Keeper - Brass	1
5	000-139-004	Ring, Solution Valve Stem - Snap Ring- S/S	1

This page intentionally left blank.

9 - Repair and Replacement

FELT VACUUM SEAL

The felt vacuum seal plays an important part in the optimum performance of your RX-20. If it is worn or unlubricated, it will not form a proper seal. Lack of a proper seal will impair the vacuuming capabilities of the unit and therefore leave behind more water in the carpet than is desirable.

To replace the vacuum seal:

1. First, remove the vacuum head assembly as previously described.
2. Using a pocket knife or similar tool, carefully pry the seal up and lift it out. If the seal appears worn or glazed so that it will not lubricate well, turn it over (see Figure 9-1). If that does not work, or if it is damaged, replace it with a new seal.
3. The manufacturer recommends changing the felt seal after 10 hours of use. Replace it with a seal that has been pre-soaked in a quality 30 weight SAE motor oil .
4. Press the seal in place and saturate it with the motor oil. If a flattened seal will be re-used, place the used seal in an oil bath to rejuvenate it.

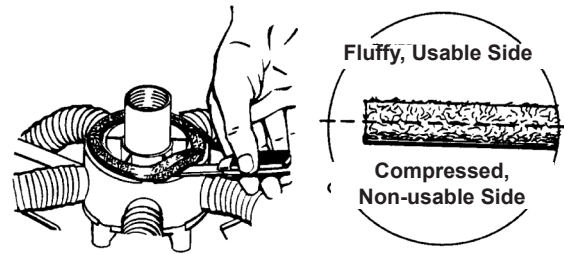

Figure 9-1. Carefully Pry Seal Up and Lift Out

NOTICE

For the seal's oil bath, use a small receptacle the size and shape of a tuna fish can.

RX-20

HIGH PRESSURE VALVE ASSEMBLY

In the event that the valve assembly needs to be replaced, follow this procedure:

1. Remove the 440 male quick connect with a wrench.
2. Remove the five hex head screws in the back plate on the handle and lift the back plate off.
3. Disconnect the stainless steel hose from the bottom of the valve assembly (see Figure 9-2).
4. Remove the bolt holding the trigger (see Figure 9-2).
5. Remove the two bolts holding the valve assembly in the handle (see Figure 9-2).
6. The valve may now be rebuilt or replaced.

CAUTION

If the valve has been frozen, inspect it for leakage before re-installing the back plate.

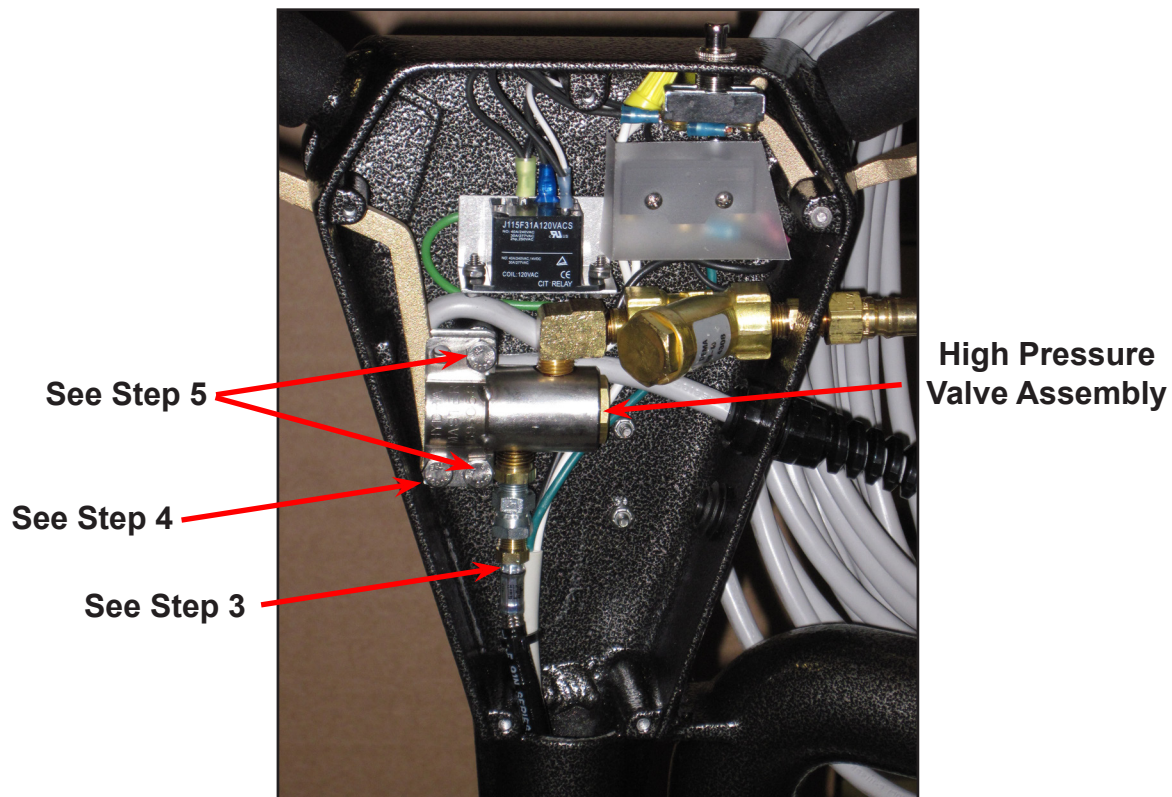

Figure 9-2. Quick Connect, Back Plate and Stainless Steel Hose Removed from Upper Handle Assembly

10 - Troubleshooting

1.0 Low Vacuum Flow at the Cleaning Heads

Possible Cause	Solution
1.1 Hub not sealing properly.	Replace felt seal with a lubricated one.
1.2 Restricted air flow.	Remove hoses from the vacuum shoe and skid assembly, and clear them of debris.
1.3 Low vacuum flow from power.	Refer to Troubleshooting section of source equipment manual.

2.0 Low Water Flow at Cleaning Heads (indicated by irregular Water Temperature)

Possible Cause	Solution
2.1 Restricted jets.	Remove jets and clear them of debris.
2.2 Clogged water strainer.	Remove water strainer and clean.
2.3 Kinked or clogged solution hose.	Remove hose. Repair or replace.
2.4 Cleaning hub not properly threaded.	Remove cleaning hub from shaft to shaft. Clean and rethread onto shaft.

3.0 Water Leak at Rotary Union

Possible Cause	Solution
3.1 Foreign matter in rotary union seal.	Discard rotary union. Order P/N 000-052-294.

4.0 Water Leak at Valve

Possible Cause	Solution
4.1 Ruptured plunger or valve O-ring.	Repair or replace damaged plunger, O-ring, seal. Check for freeze damage.
4.2 Ruptured plunger or valve O-ring.	Repair or replace damaged plunger, O-ring, seal. Check for freeze damage.

RX-20

5.0 Loss of Oil from Gearbox

Possible Cause	Solution
5.1 Loose or ruptured oil seal.	Replace damaged oil seal. Refill gearbox with oil.

6.0 No Power

Possible Cause	Solution
6.1 RX-20 wiring or power source.	Have an electrician inspect unit for possible wiring or motor problems.
6.2 Overload power source.	Locate an unused power source.
6.3 Gearbox.	Repair or replace gearbox.

7.0 Head during Operation

Possible Cause	Solution
7.1 One leg of star bent.	Straighten star.

11 - Warranty Information

The Manufacturer warrants Rotary Extractor machines of its manufacture to be free from defects in material and workmanship if properly installed, maintained, and operated under normal conditions with competent supervision. No person, agent, representative or dealer is authorized to give any warranties on behalf of the Manufacturer, nor to assume for the Manufacturer any other liability in connection with any of the Manufacturer's products. This warranty shall extend to the original Purchaser of said equipment for the periods listed below from date of installation. If repairs or replacements are made by the Purchaser without the Manufacturer's written consent, the Manufacturer's warranty shall cease to be in effect.

Machinery, equipment and accessories furnished by the Manufacturer, but manufactured by others, are warranted only to the extent of the original Manufacturer's warranty to the Manufacturer unless otherwise specified in the listing below.

The Manufacturer agrees, at its option, to repair at the point of shipment, or to replace without charge, any parts or parts of products of the Manufacturer, which within the specified warranty period shall be proved to the Manufacturer's satisfaction to have been defective when shipped, provided the Purchaser promptly notifies the Manufacturer, in writing, of such alleged defect. The Manufacturer will pay all freight and transportation charges within the United States, via normal ground shipping means, for replacement of parts covered under this warranty.

This warranty covers parts, as specified, and does not cover labor which may be necessary in completing repairs. The Manufacturer's liability to Purchaser, whether in contract or in tort arising out of warranties, representation, instructions, or defects from any cause shall be limited to repairing or replacing the defective part or parts. To qualify for warranty coverage, defective parts must be returned to the Manufacturer within 30 days. No warranty liability whatsoever shall attach to the Manufacturer unless and until the Manufacturer has received payment in full for the warranted machine or part.

Except as stated in this section and in the proceeding section and except as to title, there are no guarantees or warranties of merchantability, fitness, performance or otherwise, express, implied or statutory, and the Manufacturer shall have no liability for consequential, incidental or other damages howsoever caused.

All components not specifically referenced in the schedule below are covered under this warranty for a period of one (1) year, excepting those parts which are considered, by the Manufacturer, to be expendable in normal use, including but not limited to paint, labels and other cosmetic parts or features.

RX-20

Freeze-related damage of any RX-20 component will VOID all warranties on water- or chemical-related components, internal or external.

Hard water deposits and buildup in the RX-20 will VOID all warranties on affected components.

All recommended maintenance must be performed by competent service personnel.

Records of periodic maintenance must be kept and copies may be required to be furnished to the Manufacturer before this warranty is honored.

Coverage Schedule

Frame, Handle, Body	3 years
Gear Box	1 year
Motor	1 year
Valves, Filters, Hoses	1 year