



GTXR+

Owner's Manual

HydraMaster
11015 47th Avenue West
Mukilteo, Washington 98275

MAN-47281 Rev. C, MAY, 2018
(P/N 000-182-740D)

No part of this manual may be reproduced or used in any form or by any means (i.e. graphic, electronic, photocopying or electronic retrieval systems) without the express written permission of HydraMaster. Specifications and information in this document are subject to change without prior notice. All rights reserved. © 2015 HydraMaster

Table of Contents

GENERAL INFORMATION.....	SECTION 1
Major System Components.....	1-3
Contact Information.....	1-4
Warnings, Cautions and Notices.....	1-5
Responsibilities.....	1-9
Machine Specifications.....	1-12
High Altitude Operation.....	1-14
Local Water Precautions.....	1-14
INSTALLATION INFORMATION.....	SECTION 2
Operating the GTXR+ in Hot Weather.....	2-2
Setting Up the GTXR+.....	2-5
Orientation of Fuel Pump.....	2-6
CLEANING AND CHEMICALS.....	SECTION 3
Precautions.....	3-1
Preparing the Carpet for Extraction.....	3-2
Rinse and Recover.....	3-2
Overwetting.....	3-3
Streaking.....	3-3
Cleaning Tool Tips.....	3-4
OPERATING INSTRUCTIONS.....	SECTION 4
Start Up Procedure.....	4-3
Shut Down Procedure.....	4-5
MACHINE MAINTENANCE.....	SECTION 5
Operational Maintenance.....	5-2
Overall Machine Maintenance.....	5-4
Engine Maintenance.....	5-5
High Pressure Pump Maintenance.....	5-7
Vacuum System Maintenance.....	5-16
Descaling Procedure (Required).....	5-17
Freeze Guarding.....	5-18
WATER AND CHEMICAL SYSTEM.....	SECTION 6
ELECTRICAL SYSTEM.....	SECTION 7
Electrical System Information.....	7-1



SYSTEMS TROUBLESHOOTING	SECTION 8
Heating System.....	8-2
Chemical System	8-3
Engine	8-4
High Pressure System	8-8
Vacuum System	8-10
ASSEMBLIES AND PARTS LISTS.....	SECTION 9
Console Assembly Parts List.....	9-9
Frame Assembly Parts List	9-11
Blower Assembly Parts List.....	9-14
Silencer Assembly Parts List.....	9-15
Engine Assembly Parts List.....	9-17
Pump Assembly Parts List	9-19
Blower Heat Exchanger Assembly Parts List.....	9-21
Water Box Assembly Parts List.....	9-23
Dash Assembly Parts List	9-26
Differential Check Valve Assembly Parts List.....	9-27
By-Pass Valve Assembly Parts List.....	9-29
Hi-PSI Manifold Assembly Parts List.....	9-31
Idle Pulley Assembly Parts List.....	9-32
Exhaust Assembly Parts List.....	9-33
70 Gallon Universal Recovery Tank (URT) Assembly Parts List.....	9-35
70 Gallon Universal Recovery Tank (URT) Cover Assembly Parts List ..	9-37
Vacuum Relief Assembly Parts List.....	9-38
70 Gallon Fresh Water Tank (FWT) Assembly Parts List.....	9-42
Hose Routings.....	9-43
HOW TO ORDER PARTS	SECTION 10
Warranty Parts Orders	10-1
Parts Orders.....	10-1
Emergencies	10-1
WARRANTY INFORMATION	SECTION 11
Blower	11-1
High Pressure Water Pump	11-1
Recovery Tank	11-1
Chemical System	11-1
Control Panel	11-1
Vacuum and Solution Hoses	11-2
Cleaning Wand and Tool	11-2
Water Heating System	11-2

Hard Water Deposits 11-2
Warranty Procedure 11-2

ACCESSORIES AND CHEMICAL SOLUTIONS SECTION 12

List of Figures

Figure 1-1. Hard Water Map of Mainland United States.....	1-15
Figure 2-1. Location of Roof Vents in Vehicle	2-1
Figure 2-2. Recommended Location of GTXR+ in Van	2-3
Figure 2-3. Install Fuel Pump, Outlet Side Up	2-6
Figure 2-4. Fuel Pump Must Be in Vertical Position	2-6
Figure 4-1. GTXR+ Upper Dash Assembly	4-1
Figure 4-2. GTXR+ Lower Dash Assembly	4-2
Figure 4-3. GTXR+ Chemical System Control and Metering	4-4
Figure 5-1. Remove Valve Cap and Valve Assembly	5-8
Figure 5-2. Inspect Manifold and Old Valves	5-8
Figure 5-3. Replace Center Inlet Check Valve With Modified Check Valve.....	5-9
Figure 5-4. Apply Grease and Install Valves.....	5-9
Figure 5-5. Replace Valve Cap and Torque to 95 ft lbs	5-9
Figure 5-6. Separate Manifold from Crankcase.....	5-10
Figure 5-7. Seal Assemblies May Come Off with Manifold.....	5-10
Figure 5-8. Examine Ceramic Plungers.....	5-10
Figure 5-9. Remove Stainless Steel Plunger Bolt and Ceramic Plunger	5-11
Figure 5-10. Install O-ring, Apply Sealant and Slide Plunger over Plunger Guide	5-11
Figure 5-11. Extract Retainers and Seals.....	5-12
Figure 5-12. Seal Kit and Insertion Tool for Seal Installation.....	5-13
Figure 5-13. Install Seal Assembly Using O-Ring Grease.....	5-13
Figure 5-14. Install Retainers into Cavities.....	5-14
Figure 5-15. Press Low Pressure Seal Assembly into Cavity.....	5-14
Figure 5-16. Re-install Manifold and Torque Fasteners.....	5-15
Figure 5-17. Torque Sequence in "X" Pattern.....	5-15
Figure 5-18. Torque Bolts to 22 ft. lbs.....	5-15
Figure 5-19. Recirculation Fitting.....	5-17
Figure 6-1. Flow Diagram - View 1 of 3	6-3
Figure 6-2. Flow Diagram - View 2 of 3	6-4
Figure 6-3. Flow Diagram - View 3 of 3	6-5
Figure 7-1. Electrical Schematic.....	7-2
Figure 7-2. Wiring Diagram - View 1 of 2	7-4
Figure 7-3. Wiring Diagram - View 2 of 2	7-5

Figure 9-1.	Adhesive/Sealant Material Reference	9-2
Figure 9-2.	Console Assembly - View 1 of 6	9-3
Figure 9-3.	Console Assembly - View 2 of 6	9-4
Figure 9-4.	Console Assembly - View 3 of 6	9-5
Figure 9-5.	Console Assembly - View 4 of 6	9-6
Figure 9-6.	Console Assembly - View 5 of 6	9-7
Figure 9-7.	Console Assembly - View 6 of 6	9-8
Figure 9-8.	Frame Assembly - View 1 of 2	9-10
Figure 9-9.	Frame Assembly - View 2 of 2	9-11
Figure 9-10.	Blower Assembly - View 1 of 2	9-12
Figure 9-11.	Blower Assembly - View 2 of 2	9-14
Figure 9-12.	Silencer Assembly	9-15
Figure 9-13.	Engine Assembly - View 1 of 2	9-16
Figure 9-14.	Engine Assembly - View 2 of 2	9-17
Figure 9-15.	Pump Assembly	9-18
Figure 9-16.	Blower Heat Exchanger Assembly - View 1 of 2	9-20
Figure 9-17.	Blower Heat Exchanger Assembly - View 2 of 2	9-21
Figure 9-18.	Water Box Assembly Electrical Panel Assembly - View 1 of 2	9-22
Figure 9-19.	Water Box Assembly Electrical Panel Assembly - View 2 of 2	9-23
Figure 9-20.	Dash Assembly - View 1 of 2	9-24
Figure 9-21.	Dash Assembly - View 2 of 2	9-25
Figure 9-22.	Differential Check Valve Assembly	9-27
Figure 9-23.	By-Pass Valve Assembly - View 1 of 2	9-28
Figure 9-24.	By-Pass Valve Assembly - View 2 of 2	9-29
Figure 9-25.	Hi-PSI Manifold Assembly - View 1 of 2	9-30
Figure 9-26.	Hi-PSI Manifold Assembly - View 2 of 2 Exhaust Assembly	9-31
Figure 9-27.	Idler Pulley Assembly Exhaust Manifold Assembly	9-32
Figure 9-28.	Exhaust Diverted Assembly	9-33
Figure 9-29.	70 Gallon Universal Recovery Tank (URT) Assembly	9-34
Figure 9-30.	70 Gallon Universal Recovery Tank (URT) Cover Assembly	9-36
Figure 9-31.	Vacuum Relief Valve Assembly	9-38
Figure 9-32.	70 Gallon Fresh Water Tank (FWT) Assembly - View 1 of 2	9-40
Figure 9-33.	70 Gallon Fresh Water Tank (FWT) Assembly - View 2 of 2	9-41

1 - General Information

The GTXR + is the latest multi surface cleaning/water recovery system from HydraMaster, featuring a 23 HP air-cooled engine and the dual oil bath Tuthill Dominator 4005 Tri-lobe Blower.

Standard equipment for the GTXR + include a 70 gallon recovery tank, 70 gallon rotomolded fresh water tank (FWT), Evolution Truckmount Wand, and a 5 gallon chemical jug.



Other options include:

- a 100 gallon recovery tank
- a recovery tank automatic pump out system (Automatic Water Dump System, or AWDS)
- a Thru Floor Exhaust Kit
- Hydra Cradle Fresh Water Tank and Hose Reels
- RX-20 Rotary Extraction Wand

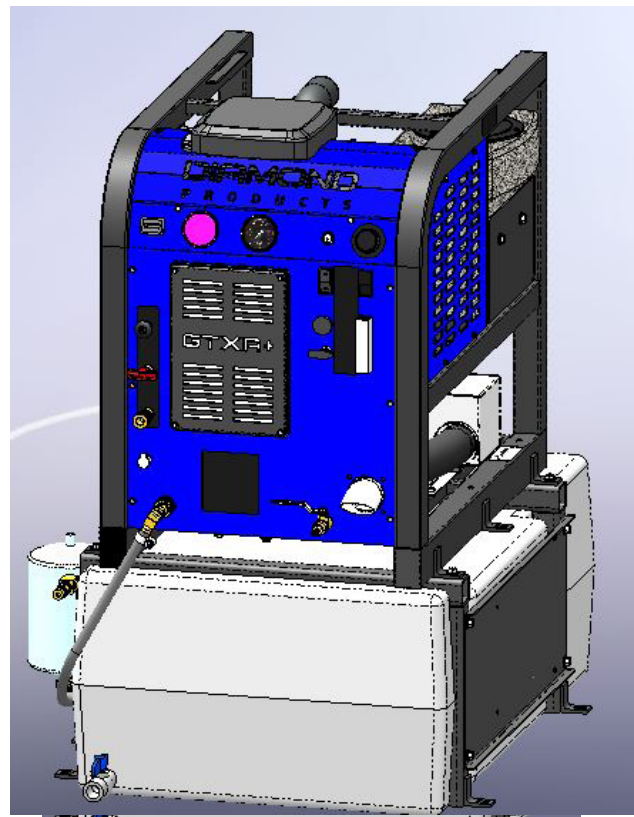

GTXR+

This Owner's Manual contains installation and operation instructions as well as information required for proper maintenance, adjustment and repair of the GTXR +. Component troubleshooting guides have also been included for your convenience.

It is the purpose of this manual to help you properly understand, maintain and service your GTXR +. Follow the directions carefully and you will be rewarded with years of profitable, trouble-free operation.

It is imperative that no section of this manual be overlooked when preparing for operation of the GTXR +. Please read the manual to familiarize yourself with the operation of your GTXR +, paying special attention to all **Warnings and Cautions**.

This section of the manual contains the following information:

- Major System Components
- Contact Information
- Warnings, Cautions and Notices
- Responsibilities
- Machine Specifications
- High Altitude Operation
- Local Water Precautions

NOTICE

Photographs and illustrations included in this document can represent optional equipment as well as standard equipment.

MAJOR SYSTEM COMPONENTS

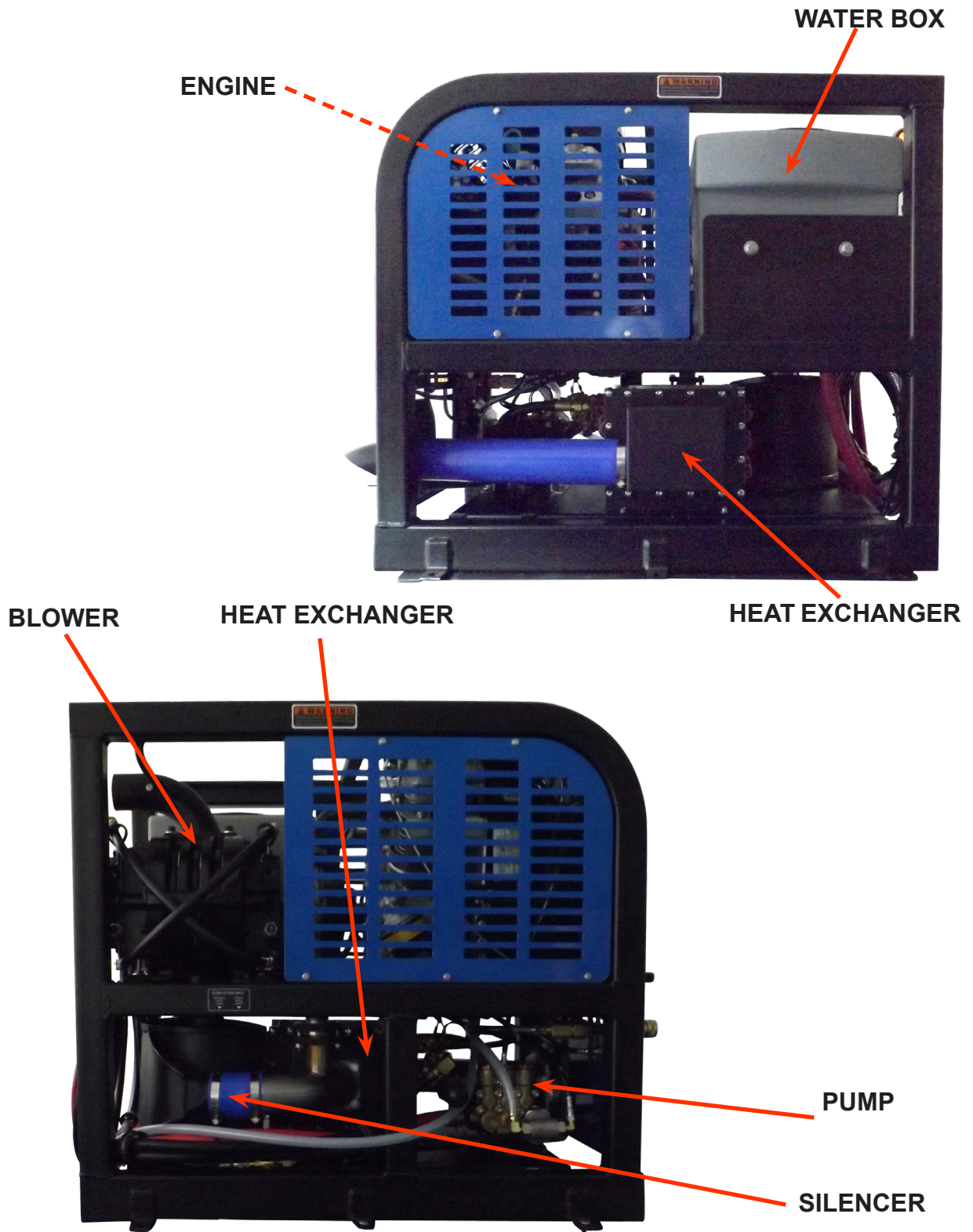



CONTACT INFORMATION

If you have any questions regarding the operation, maintenance or repair of this machine, please contact your local distributor.

To find a local distributor, please visit our website at <http://hydramaster.com/HowToBuy/DealerLocator.aspx>

If your question cannot be resolved by your distributor or by the information within this manual, you may contact HydraMaster direct using the following phone numbers.

HOURS	TELEPHONE NUMBERS	E-MAIL ADDRESSES
Monday-Friday 7:00 a.m. to 5:00 p.m. Pacific Time	Technical Support (800) 426-1301 FAX : (800) 426-4225	Technical Support techsupport@hydramaster.com
	Customer Service/Parts (800) 426-1301 FAX : (800) 426-4225	Customer Service/Parts parts@hydramaster.com

When calling your distributor, be sure to reference the serial number and date of purchase.

FOR YOUR REFERENCE:

Serial No. _____

Date of Purchase: _____

Purchased From (Distributor): _____

WARNINGS, CAUTIONS AND NOTICES

⚠ WARNING

HydraMaster uses this WARNING symbol throughout the manual to warn of possible injury or death.

CAUTION

This CAUTION symbol is used to warn of possible equipment damage.

NOTICE

This NOTICE symbol indicates that federal or state regulatory laws may apply, and also emphasizes supplemental information.

GTXR+

Warnings and Cautions specific to the GTXR + include the following:

NOTICE

During the operation of the truckmount many components are in motion. Never touch any part of the truckmount that is in motion. Serious injury may result.

⚠ WARNING

During the operation of the truckmount many surfaces will become extremely hot. Never touch hot surfaces. Serious injury may result.

⚠ WARNING

The operation of this truckmount can produce noise levels exceeding 85 decibels to a distance of 10 ft. The Occupational Safety and Health Administration (OSHA) recommends the use of hearing protective equipment if a person is exposed to an average of 85 decibels over an 8-hour period. Check with local and state agencies concerning hearing conservation rules.

⚠ WARNING

During the operation of the truckmount carbon monoxide and other toxic fumes are produced. Position the vehicle so that any fumes produced will be directed away from inhabited areas and any points of building entry (doors, windows, air conditioning units, fans, etc.). Do not occupy the vehicle while the truckmount is in operation. Serious injury may result.

⚠ WARNING

During the operation of the truckmount, chemicals known to the State of California to cause cancer, birth defects and other reproductive harm are produced by the engine exhaust.

⚠ WARNING

Never operate the truckmount with a portable gas container inside the vehicle. Doing so will increase the risk of fire and explosion. Serious injury or death may result.

Transporting a vented fuel container that presently contains, or has ever contained in the past, a flammable liquid is strictly forbidden by HydraMaster and by federal and state regulations. Doing so will increase the risk of fire and explosion. Serious injury or death may result.

⚠ WARNING

Never smoke in or around the truckmount. Doing so will increase the risk of fire and explosion. Serious injury or death may result.

⚠ WARNING

During the operation of the truckmount the exhaust system will become extremely hot. Keep all flammable materials away from the truckmount exhaust system. Failure to do so will increase the risk of fire and explosion. Serious property damage may result.

CAUTION

Never operate the truckmount when the vehicle is tilted more than 10 degrees in any direction. Doing so will result in improper lubrication of the internal components, and will increase the risk of serious component or engine damage.

CAUTION

Never perform cleaning operations when the truckmount engine is running at the IDLE throttle position. Failure to do so will increase the risk of serious component or engine damage.

CAUTION

Never operate the truckmount with the vehicle doors closed. Doing so results in extremely high temperatures inside the vehicle and will lead to serious component or engine damage.

CAUTION

Never use concentrated acids or solvents (including d-limonene) in the truckmount water system or chemical system. Use of these products will cause serious component damage.

CAUTION

Never operate the truckmount with a water hardness reading measuring 3.0 grains per gallon or higher. Using reading than 3.0 grains per gallon will cause scale to build up inside the truckmount water system. Scale build up causes serious component damage. Test all water prior to use and use water softening equipment if necessary.

GTXR+

CAUTION

Never allow water to freeze inside the truckmount. Serious component damage will occur. Perform all freeze guarding procedures outlined in this digital Owner's Manual.

CAUTION

Many vehicles have critical components mounted directly below the floor that can easily be damaged. Before drilling holes in the floor of the vehicle inspect the underside of the vehicle for critical components. Failure to do so may result in damage to the vehicle.

CAUTION

Use of the vacuum recovery system when stripping or otherwise removing wax from floors is specifically excluded as an approved use of the truckmount. Failure to follow this exclusion may lead to component failure and will invalidate your warranty.

CAUTION

Use of the vacuum recovery system for "dry cleaning", without corresponding solution application (i.e. duct cleaning), is specifically excluded as an approved use of the truckmount. Failure to follow this exclusion may lead to component failure and will invalidate your warranty.

CAUTION

If concentrated acids or solvents are used to pre-treat surfaces before power washing, do not recover them through the vacuum system. Failure to follow this exclusion may lead to component failure and will invalidate your warranty.

RESPONSIBILITIES

Purchaser's Responsibilities

- Prior to purchasing a van, ensure that the payload is suitable for all of the equipment that will be installed and transported. This includes and is not limited to: the truckmount, recovery tanks, fresh water tanks and any other on-board water hose reels, hoses, cleaning tools, chemicals and drying equipment. Payload capacity information is available through the auto dealer, the manufacturer's web site, and is also located on the door pillar of the driver's side door.
- Purchase a heavy duty Group 24 (500+ CC Amps) battery for this truckmount. This is normally available from the installation dealer.
- Prior to dropping your van off at the distributor for the truckmount to be installed, have a spray-on bed liner applied to the floor such as Rhino Lining® or Line-X®.

NOTICE

Plywood and carpet are not recommended.

- Prior to operating the truckmount, read this manual in its entirety and familiarize yourself with the information contained here. Special attention should be paid to all ***Warnings and Cautions***.
- The distributor is responsible for the correct installation of the truckmount. The distributor is also responsible to train you in the correct and proper operation and maintenance of the truckmount.

NOTICE

Any modification of the truckmount may void the warranty.



Distributor's Responsibility

Acceptance of Shipment

Before accepting the truckmount, check the following:

1. The truckmount should be free from any damage during shipping. Do not sign the delivery receipt until you have closely inspected the truckmount and noted any damage on the delivery receipt. Hidden damage may be present even if the box looks okay. It is recommended that the box be opened before you sign for the shipment.
2. Check the packing list and verify that all items are accounted for.

Installation Responsibilities

- Ensure proper payload capacity. It is the distributor's responsibility to verify that the equipment package does not exceed the vehicle capacity.
- Ensure installation of a safe fuel tap system and through-floor fittings as provided by HydraMaster.
- Ensure proper placement of the truckmount, recovery tank, fresh water tank, and accessories in the vehicle, and check that they are secured with bolts and back up plates. The distributor should verify that the owner is in agreement with the layout.
- Ensure proper connection of the fuel lines.
- Ensure proper connection and installation of the battery. Verify that the battery is in accordance with HydraMaster's recommendation.
- Check the pump, vacuum blower and engine oil levels prior to starting the truckmount.
- Start and run the truckmount and check that all systems function properly.
- Test all hoses, wands and other accessories for correct operation.
- Ensure timely return of the document package.

Training

The distributor should provide a thorough review of the operation manual with the purchaser along with instruction and familiarization in:

1. How all the truckmount's systems function.
2. All safety precautions and their importance.
3. How to correctly start and shut down the truckmount.
4. How to correctly clean with the truckmount.
5. Where and how often to check and change component oil levels.
6. Freezing damage and how to avoid it. This includes explaining proper freeze guarding procedures.
7. How to do basic troubleshooting of the truckmount.
8. Hard water damage and how to avoid it. This includes how to determine if hard water exists in your area and the installation and use of water softening systems.
9. The truckmount's warranty and warranty procedures.

GTXR+

MACHINE SPECIFICATIONS

Frame Dimensions	24"W x 31"H x 36"D	
Weight	563 lbs	
Engine	23HP Briggs and Stratton air-cooled	
	Pressurized Oil System	Engine Oil: 5W-30 Synthetic
	Capacity	Approx. 1 1/2 quarts, or 48 oz (when changing oil and filter)
	Engine rpm	3,000 rpm
	Fuel Consumption	1.1 gph
Ignition	Electric Keystart	
Vacuum Blower - Tuthill 4005	Oil Type	Blower Oil: Pneulube
	Gear End Capacity	Approx. 5.8 oz
	Drive End Capacity	Approx. 4.7 oz
	Blower rpm	3,000 rpm
Water Pump	3.5 gpm Plunger Pump, Electric Clutch Control	Oil Type 30W non-detergent
Drive System	Direct-drive Hayes 40-series Coupler	
Engine Exhaust Diverter	Automated Diverter Control (ADC) Temperature Control	
Operating Pressure	0 - 1,000 psi	
Chemical System	Stainless Steel Last-Step Chemical Injection, Meter Controlled	
Heating System	Finned Tube Heat Exchanger	

Standard Equipment	Runtime Hour Meter	
	Chemical Flow Meter (0-10 Gph)	
	Chemical Flow Control Valve	
	Vacuum Gauge (0-30" Hg)	
	Solution Pressure Gauge (0 - 1,500 Psi)	
	Solution Pressure Adjustment	
	Pre-Wired Pump-In Switch	
	Pre-Wired Pump Out Switch	
	Fresh Water Inlet	
	Water System Drain Valve	
	Diagnostic/Status Lights	
	Engine Choke	
	Engine Throttle	
	Electrical Circuit Protection (Fuse Protected)	
	Solution Temperature Control Selector	
	Fresh Water Tank (FWT)	70 Gallon Rotomold
	Universal Recovery Tank (URT)	70 Gallon URT
	Wand, 1.5" x 13" EVO	
Optional Equipment	Recovery Tank pump out	Automatic Wastetank Disposal System (AWDS)
	Recovery Tank	100 Gallon URT
	Hoses	
	Wand, 2.0"	
	Thru Floor Kit	

Spare Parts - Engine	HM part number
Oil Filter	000-049-014
Fuel Filter	000-049-258
Foam Pre-Air Filter	000-049-053
Air Filter	000-049-012
Exhaust Gasket	000-057-082
Spark Plug	000-106-016

GTXR+

HIGH ALTITUDE OPERATION

Elevation plays a key role in how the truckmount will operate. Operation at high altitude (above 5,000 ft [1,524 m]) may require a high-altitude carburetor jet. Use of this jet at high altitude will improve power, reduce fuel consumption and help reduce excessive carbon build-up in the exhaust and heat exchanger systems.

Contact the local Briggs and Stratton dealer or HydraMaster to obtain the proper jet size. Find your local Briggs and Stratton dealer at <http://www.vanguardengines.com/where-to-buy/dealer-locator/>

LOCAL WATER PRECAUTIONS

The quality of water varies greatly. Many areas have an excess of minerals in the water which results in what is commonly called “hard water.” These minerals tend to adhere to the insides of heater coils and other parts of the machines causing damage and a loss of cleaning effectiveness. This influences the reliability and efficiency of equipment in direct proportion to the level of hardness.

Hard Water Advisory

HydraMaster recognizes that any hard water deposits which might occur within the water system of our truckmounts is a serious problem. The precision technology of truckmount heat exchanger systems is intolerant of any foreign material. Hard water deposits will ultimately decrease the performance of the system and are expected to seriously lower the reliability of the machine.

To validate a machine’s warranty, HydraMaster requires that all machines operating in designated “Hard Water Areas” (3.0 grains or more per gallon [3.79 litres]) be fitted with a water softening system, or a properly installed magnetic-type descaler must be used and maintained. Periodic descaling or acid-rinsing alone is not adequate in these areas. HydraMaster does not recommend any particular type or brand; however, the relative effectiveness of some types of magnetic descalers or softeners may require additional periodic use of descaling agents.

HydraMaster also recommends, in the strongest possible terms, that machines in all areas be fitted with a water softening system for improved operation and reliability.

CAUTION

Failure to take appropriate measures to prevent scale build up can result in system failure and loss of warranty on affected parts.

Hard Water Area Map

The hard water map, shown in Figure 1-1, defines hard water areas in the continental United States which compromise fluid related components such as hoses, fittings, heaters, pumps, valves and water-cooled engines. For other countries, hard water area maps can be obtained from geological societies.

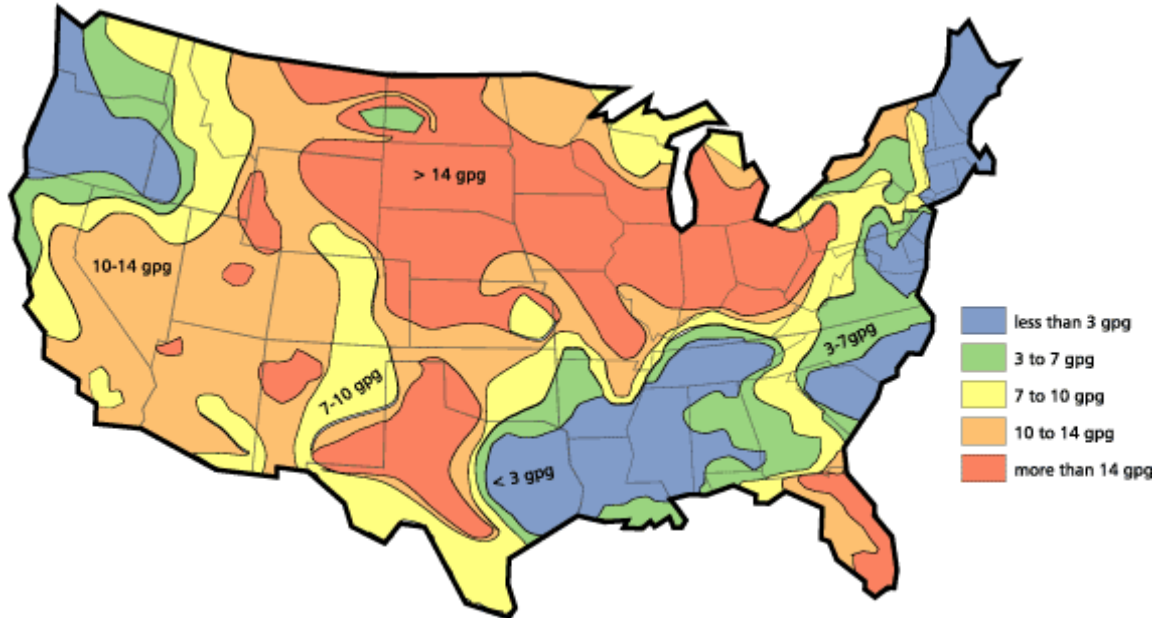

Figure 8-1. Hard Water Map of Mainland United States

NOTICE

The map shown in Figure 1-1 is provided for general reference only. Water hardness in your geographical location should be confirmed by testing.

GTXR+

Water Softener

Cleaning efficiency and equipment life is increased, chemical use decreased, and the appearance of cleaned carpets enhanced when water softeners are incorporated in hard water areas. HydraMaster strongly urges the use of water softener units with the in areas exceeding 3.0 grains per gallon.

Failure to use a water softener in these areas will invalidate the machine's warranty. Referring to the hard water area map shown Figure 1-1, determine the quality of water in your area and take immediate action if the water hardness exceeds 3.0 grains per gallon.

The relatively low cost of a water softener service is more than made up for by an increased life of machine parts, reduced chemical costs and continued cleaning efficiency. The water softener will also increase the effectiveness of the cleaning chemicals, therefore less chemical will be needed.

Contact a water softener distributor in your area for information on the rental of a simple water treatment unit to carry in your truck. Be sure to charge the water softener in accordance with the capability of the softener.

For example: If the softener will treat 900 gallons of water and the machine uses an average of 30 gallons/hour, for an average of 5 hours a day, this equals 150 gallons per day. In 6 days the machine would use 900 gallons of water. Therefore, the softener would need to be charged every 6 working days for maximum softening.

Waste Water Disposal Advisory

There are laws in most communities prohibiting the dumping of recovered “gray” water from carpet cleaning in any place but a sanitary treatment system.

The cleaning rinse water, recovered into your unit’s vacuum tank, contains materials such as detergents, and must be safely processed before entering streams, rivers and reservoirs.

In most cases, an acceptable method of waste water disposal is to discharge into a municipal sewage treatment system after first filtering out solid material such as carpet fiber. Access to the sanitary system can be obtained through a toilet, laundry drain, RV dump, etc. Permission should first be obtained from any concerned party or agency.

One disposal method which usually complies with the law is to accumulate the waste water and haul it to an appropriate dump site. Another solution to the disposal problem is to equip your GTXR + with an automatic pump-out system. These systems are designed to remove waste water from the extractor’s recovery system and actively pump the water through hoses to a suitable disposal drain.

HydraMaster makes an automatic pump-out system, called AWDS, which can be ordered with new equipment or installed later.

When properly configured, the systems will continuously monitor the level of waste water and pump it out simultaneously with the cleaning operation. The hidden benefit of this process is that the technician does not have to stop his/her cleaning to empty the recovery tank.

NOTICE

IN ACCORDANCE WITH EPA, STATE AND LOCAL LAWS, DO NOT DISPOSE OF WASTE WATER INTO GUTTERS, STORM DRAINS, STREAMS, RESERVOIRS, ETC.

The penalties for non-compliance can be serious. Always check local laws and regulations to be sure you are in compliance.

2 - Installation Information

Although there are many different heavy duty vehicles used for carpet cleaning equipment, the preferable vehicle for a GTXR + installation is a cargo van with a heavy-duty suspension package and a 3/4 HD ton capacity. If a fresh water tank is added, a one ton or larger capacity van is required.

Prior to installation of the GTXR +, HydraMaster recommends installing a spray-on bed liner in the vehicle. This provides 'metal to cushion' mounting rather than 'metal to metal' and makes for an attractive van interior.

HydraMaster also recommends installing roof vents in vehicles operated in hot weather locations. Roof vent positions are shown in Figure 2-1. Consult your local RV distributor about selection and/or installation of powered roof vents.

For best results, the fan should draw air into the vehicle which will supply cooler air to the air cleaner intake.

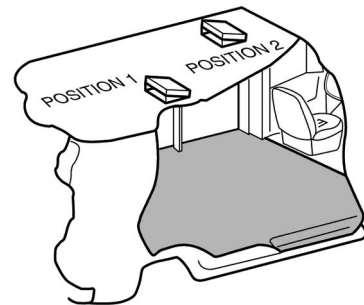

Figure 8-1. Location of Roof Vents in Vehicle

CAUTION

HydraMaster requires a powered roof vent above the air cleaner intake. Failure to install a powered roof vent in such a manner may result in serious component or engine damage.

GTXR+

OPERATING THE GTXR + IN HOT WEATHER

HydraMaster recommends the following steps when operating the GTXR + during periods of hot weather (95° F or higher). This will help ensure that your GTXR + continues to run at 100% capacity during even the hottest days.

1. A minimum of 9" (22.9 cm) of clearance is required on both sides of the GTXR +, when installed. Ensure that additional equipment or other materials are not stored at the sides or on top of the GTXR +. Unobstructed airflow around the unit is critical for cooling the engine and other components.
2. For side-door vans with "barn doors", open the doors as wide as their construction will allow. Be sure to open the doors beyond their standard "straight-out" position, if possible, by releasing the stops and putting the doors in their fully extended position.
3. Provide cross-ventilation. When possible, keeping the rear doors open while the GTXR + is running will substantially reduce the temperature inside the van and will provide a path for cooling air flow. For rear-mount installations, open up the other doors in the van.
4. Consider adding powered roof vents to the vehicle (if not already installed). These vents can significantly reduce interior temperatures and will result in much cooler operation.

CAUTION

Use caution when drilling any holes through the van floor. Many vans have critical components mounted directly below the vehicle floor that could be damaged by a misplaced drill bit.

LOCATING THE GTXR + IN VEHICLE

There are two recommended entry points on the vehicle for the GTXR + installation: the side door or the rear doors.

Most installations are through the side door. This provides rear access for accessories and hoses as well as unobstructed access to the component/working side of the machine, thus making it a bit easier to perform maintenance and/or repair without removing the unit from the truck.

Rear mounting requires the unit to be slid to the right side as far as possible. Although installing the GTXR + through the rear door partly limits working access, it does direct the noise away from the cleaning site.

In addition, rear mounting not only provides adequate working space on the component side of the unit but also improves weight distribution inside the van (engine and component weight line up over drive shaft). Some cleaners in colder geographical areas prefer this placement for better traction in ice and snow. Also, it is physically easier to load the unit into the rear door due to the height of the vehicle bed.

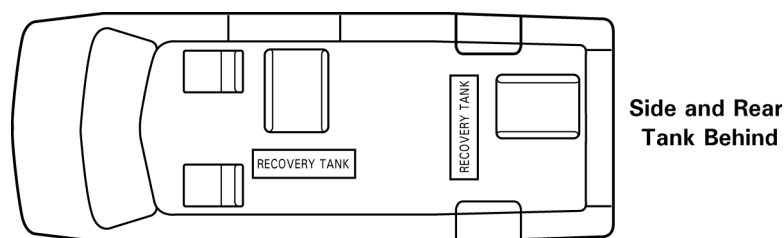

Figure 8-2. Recommended Location of GTXR + in Van

Secure Installation

No matter how the unit is installed, check to see if the GTXR + is properly secured to the floor of the van with the hardware provided. This safety measure will ensure that the machine will not slide inside the van. See Figure 2-2 for the correct installation.

GTXR+

⚠ WARNING

A sudden or crash stop will cause the machine to rocket forward if not properly secured. To prevent serious personal injury, ensure that the GTXR + is well secured to the floor of the vehicle with the hardware supplied. Protect yourself and the machine.

⚠ WARNING

HydraMaster strongly recommends that the exhaust from the front of the machine be vented down under the truck to prevent carbon monoxide from entering the job site. **Always park the truck so the exhaust is blowing away from the job site.**

⚠ WARNING

Never operate this machine with a portable gas can inside the truck. Doing so increases the risk of a fire or explosion.

⚠ WARNING

Mount a fire extinguisher just inside the rear or side door for emergencies.

⚠ WARNING

Do not use a portable propane tank inside of the truck or van. It is dangerous and illegal in most states.

⚠ WARNING

Transporting any vented fuel container that presently holds or has ever held a flammable liquid in a vehicle containing the GTXR + is strictly forbidden by HydraMaster Corporation and by federal and state regulation.

⚠ WARNING

The engine exhaust from this product contains chemicals known to the State of California to cause cancer, birth defects or other reproductive harm.

SETTING UP THE GTXR +

Prior to operating the GTXR +, follow these steps:

1. Adjust the vacuum relief located on the recovery tank by capping all the vacuum inlets. The machine should be set to 14" Hg maximum.

CAUTION

Setting the vacuum level higher than the recommended value can result in an increased risk of serious component damage.

The GTXR + is shipped from the factory with antifreeze added to the solution system.

Recover this antifreeze and dispose of the recovered antifreeze as stated in the local laws and regulations.

⚠ WARNING

KEEP ANTIFREEZE OUT OF REACH OF CHILDREN AND ANIMALS. Drinking antifreeze can cause death.

If required, dispose of antifreeze at facilities licensed to accept household hazardous waste. If permitted, dispose of antifreeze in sanitary sewer systems. Do not pour antifreeze into storm sewers, septic systems, or onto the ground. Doing so causes health and environmental dangers.

CAUTION

Ensure the antifreeze is completely drained from the solution system. If any antifreeze remains in the system, it could damage machine components and damage fabric.

ORIENTATION OF FUEL PUMP

For proper fuel pump operation and fuel flow, the vehicle's fuel pump must be installed in a lower position with respect to the fuel tank and in as vertical a position as possible (outlet side up - see Figure 2-3 and Figure 2-4).

Mount the fuel pump away from sources of heat

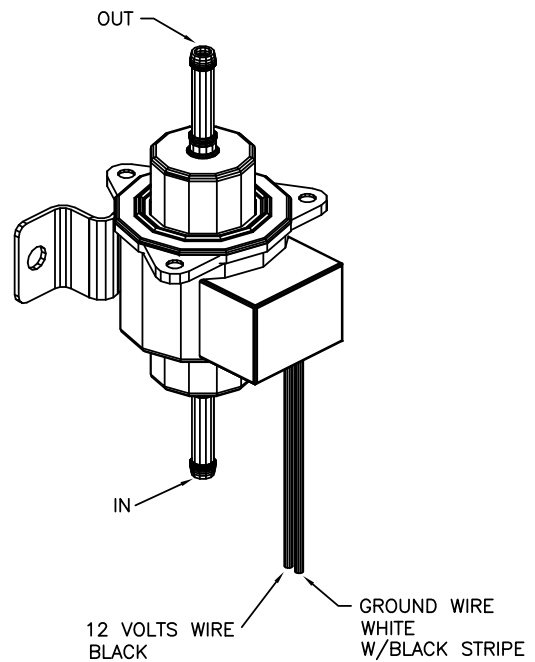

Figure 8-3. Install Fuel Pump, Outlet Side Up

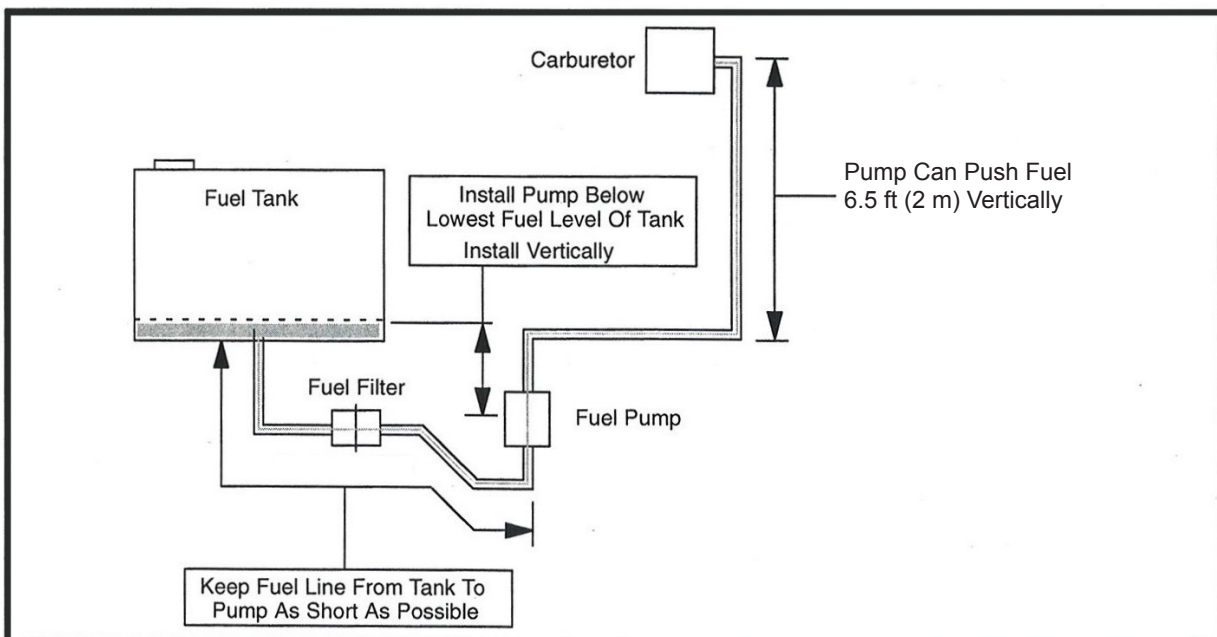

Figure 8-4. Fuel Pump Must Be in Vertical Position

3 - Cleaning and Chemicals

Your HydraMaster truckmount has been engineered using the latest and most sophisticated technology available to produce the finest carpet cleaning results possible. Despite this, it remains only a tool of the carpet cleaning trade and can produce only as good a job as the person operating it.

HydraMaster strongly recommends attending an Institute of Inspection, Cleaning and Restoration Certification (IICRC) approved school as soon as possible and to always follow the IICRC guidelines when cleaning.

This section describes the carpet cleaning procedure in the following areas:

- Precautions
- Preparing the Carpet for Extraction
- Rinse and Recover
- Overwetting
- Streaking
- Cleaning Tool Tips

PRECAUTIONS

The use of some chemicals (such as concentrated acids and/or solvents) in your truckmount can seriously damage the internal plumbing and high pressure pump.

HydraMaster strongly recommends purchasing a water softener to prevent the buildup of scale and hard water deposits in your truckmount.

HydraMaster recommends only the use of chemicals containing rust and corrosion inhibitors and water softening agents to prevent chemical buildup which may lead to component failure and warranty invalidation.

CAUTION

Increased demand for a neutralizing rinse results in the need for special care when using these acid based chemicals in your truckmount. The negative side of these products is the corrosive effects the acid can have on metals, including fittings, pumps, heat exchangers, etc.

HydraMaster's ***ClearWater Rinse™*** has been formulated to protect vital components. HydraMaster will not warranty parts that have been damaged from using acid products that have obviously caused failures.

PREPARING THE CARPET FOR EXTRACTION

Pre-Vacuum the Carpet

Whether you instruct the customer to pre-vacuum or you offer it as part of your service, proper vacuuming will make your job easier with superior end results. The more time spent removing loose particulate soil, the easier it will be to remove the oily soil stuck to the fibers.

Pretreat the Carpet

This process of applying traffic lane type chemicals to the carpet (whether by sprayer or rotary scrubber) is essential prior to extraction with your truckmount.

By applying cleaning agents to the carpet and letting them dwell 10-20 minutes prior to rinsing, you allow the product to dissolve and emulsify the oily, sticky binders holding the soil to the fiber. This will allow more soil to be removed in one or two cleaning passes and help prevent overwetting.

Remember the solution coming out of your cleaning tool is only in contact with the carpet fiber for a few seconds. Relying on the rinse detergent to do the majority of the cleaning will result in overly long dry times and excess detergent residue left in the carpet.

HydraMaster recommends the use of our pre-sprays: **Fastbreak™** for residential carpet and **Blitz™** for commercial carpet needs.

RINSE AND RECOVER

Whether you are using a wand or a rotary extraction tool, you should clean an area approximately 3 ft. x 3 ft. with the solution valve open then immediately go over that area with vacuum only to remove any excess moisture.

CAUTION

Olefin fiber is becoming more popular, particularly in commercial installations. The process mentioned above can leave excessive residual moisture because olefin fibers will not absorb any of the cleaning solution. You must only apply solution during the backward stroke of the wand so it can be immediately captured by the vacuum head. RX-20® users should follow each pass with a dry pass. Failure to follow this procedure will cause solution to flow to the back of the carpet along with some of the soil. This, along with any soil imbedded in the backing, will be wicked to the surface of the fibers as the carpet dries.

HydraMaster recommends the following rinse aids: Alkaline - **Hydra-Dri Powder™** or **Hydra-CleanLiquid™**. Acid - **Clear Water Rinse™**.

NOTICE

For more information about HydraMaster's complete chemical product line, visit this webpage: <https://HydraMaster.com/Chemicals>.

OVERWETTING

Overwetting is an annoyance to all concerned. Extended drying times will leave the customer with a negative impression of both the cleaning company and the process used.

There are several factors that will cause overwetting:

1. Too few vacuum strokes.
2. Clogged vacuum blower filter or Recovery Tank lid not sealing properly.
3. Recovery Tank drain valve left partially open.
4. Obstructed, cut or kinked vacuum hoses.
5. Obstructed vacuum hoses while cleaning a heavily foam-saturated carpet (it is recommended to use a crystal type defoamer distributed evenly over the carpet).

STREAKING

Streaks in the carpet can appear in both clean or dirty areas and normally appear in heavily soiled, light colored carpets.

Possible reasons of streaking may include:

1. Clogged or improperly angled spray nozzles.
2. Spray nozzles that overlap, concentrating the solution.
3. A partially clogged vacuum head.
4. Inconsistent solution temperature.

GTXR+

CLEANING TOOL TIPS

Wands

With a wand, keep cleaning strokes short, front to back, and run a “dry pass”.

After pulling the wand for a strip of 3 or 4 ft long with the solution trigger activated, go back up to the top of the stroke, and make a “dry “ pass [i.e. no solution flowing]. This gives the wand a second chance to pick up the solution on the carpet.

If you do not run a dry pass, the carpet can take longer to dry, and, possibly, the pad under the carpet can become saturated.

Be aware of the carpet seams; try to use strokes that are parallel with the seam. Avoid pulling the wand across the seam. Every stroke can peel the seam connection and pull the carpet off the floor.

Also, tilt the wand handle down [head up] to move the tool forward, and away from you, on the carpet. This means less pull on the carpet and less work for you.



The Evolution Wand is truly the next evolution in wand design and performance. The Aluminum tube and Rotomolded head make it extremely lightweight which helps to reduce fatigue on the technician. The sealed Delrin® glides help the wand to be easily pushed across the carpet, and are tapered to keep a good seal on the fibers.

No other tool has made such a dramatic increase in soil removal and water recovery. The laminar airflow design of the Evolution wand has boosted the performance of some portable extractors from a bronze to a gold level of certification from the Carpet and Rug Institute's Seal of Approval Program for tested cleaning performance. The Evolution will change the way carpets are cleaned.

Available in two sizes: a 12" head with 1-1/2" tube and two jets or a high production 16" head with 2" tube and 6 jets.

Evolution Wands

Half the weight, twice the performance.
The Evolution is not your standard wand.



16"
2" Evolution Truckmount Wand
Item #163-035

13"
1-1/2" Evolution Wand
Item #163-034

GTXR+



1½" HydraHoe Carpet Cleaning Wand

Glides over carpet without chattering! 12" wide head increases production. High temperature, high pressure, stainless steel fabrication, stainless valve, quick coupler and assist handle.

Item #163-020

2" S-Bend Wand

This 12" wide wand has two jets. It uses a 1¾" tube for improved airflow and comes with an expanded 2" vacuum hose connection.

Item #163-104

1½" S-Bend Two Jet Wand

This 12" wide S-Bend wand has two jets. It uses a 1½" tube and glides over the carpet for easy operation.

Item #100-011-106

UT-14 Truckmount Stair Tool

The best stair tool on the market today. This tough stainless steel hand tool is 14" long with 6" wide cleaning head and stainless steel valve with quick coupler, assist handle.

Item #163-009

UT-40 Utility Cleaning Tool

An all purpose tool for cleaning carpeted divider panels, under restaurant booths, landings, stairs and hard to reach carpeted areas. All stainless construction, 9" wide head and 40" long shaft allows operator to "stand-up" when cleaning stairs.

Item #163-008

Rotary Tools

HydraMaster's selection of Rotary Extraction Tools includes the RX-15H and the RX-20®.

RX-15H Hard Surface Cleaning Tool

The RX-15H can be used to clean tile, concrete and stone floors.

Select the appropriate pre-spray and apply to the floor. Usually, a 5 minute or less dwell time is ideal. Excessive dwell time may actually retard the cleaning process by soaking in deeper and requiring more drying time before sealing.

Avoid letting the pre- spray dry on the floor by extracting it within the 5 minute time frame.

Recommended pressure is 700 to 1,500 psi, and recommended temperature is up to 200 degrees F.

It is usually easiest to move at a moderate rate forward and backward. You need only overlap enough to assure complete coverage.

Moving the RX-15H too fast will create a spiral pattern in the grout or tile. Slow down so this pattern does not occur.



GTXR+

RX-20 Tool for Carpet, Hard Surface and Bonnet Cleaning

Before turning on the RX-20, adjust the handle; it should rest right below or even with the bottom of your pants' front pockets, with the tool resting flat on the floor. Take your time in adjusting the tool's height; make sure the head of the tool is flat with the floor while you are holding the handle. Relax your posture; the more difficult it is to hold the tool's head flat on the floor surface, the more quickly you will tire.

While the tool is running, control the left and right movements of the tool by tilting the head to the front and back, and lifting the handles up and pushing the handles down. The tool can be driven to the forward and backward by tilting the head of the unit to the left and right. The head must be turning to use the self driving feature of the tool, and only requires a slight bit of pressure to handles to get the head to move the tool across the floor.

As with the wand, drying times will be improved if you run a dry pass between wet passes. Hold down the solution trigger and move the unit left or right across the floor 3 or 4 ft, then immediately back across the same pass, without the solution flowing, to make the dry pass. Make the next pass half-overlapping the previous pass.

Use the RX-20 in very heavily trafficked areas or if it has been a long time since the carpet has been cleaned. Beware of the seam edges of carpets and transition edges between floor surfaces. Use extreme caution when cleaning these areas.

Sometimes it is necessary to use an edge tool or wand to run the perimeter of the room on in difficult-to-reach areas where the circular head of the rotary units will not reach.

For Truckmount or Portable Carpet Cleaning Systems

- ***Aggressive restorative extractor tool for carpet, hard surface and bonnet cleaning***
- ***Labor-saving, ergonomic design***
- ***Superior agitation for cleaning stains, heavily soiled and matted carpet***
- ***Durable construction for long life***
- ***Reduces fatigue of the operator***



The 5 vacuum heads and 3 jets rotate at 130 rpm, creating 650 complete cleaning passes per minute.

Upholstery Tool - DriMaster 3

Use the upholstery tool on small rugs and furniture. When you clean rugs, be sure that the temperature and chemicals are safe for that particular type of rug.



As with the larger tools, do not leave the surface of the upholstery too wet. Adjust the volume of water on the tool without it touching any surface: the water should just barely come out of the tool before the vacuum pulls it back in. The water will only just spray the top layer of the furniture and the vacuum will pull the dirty water back into the tool.

If you find it necessary to do a dry pass, keep strokes short to limit the amount of water that comes into contact with the fabric surface.

GTXR+

4 - Operating Instructions

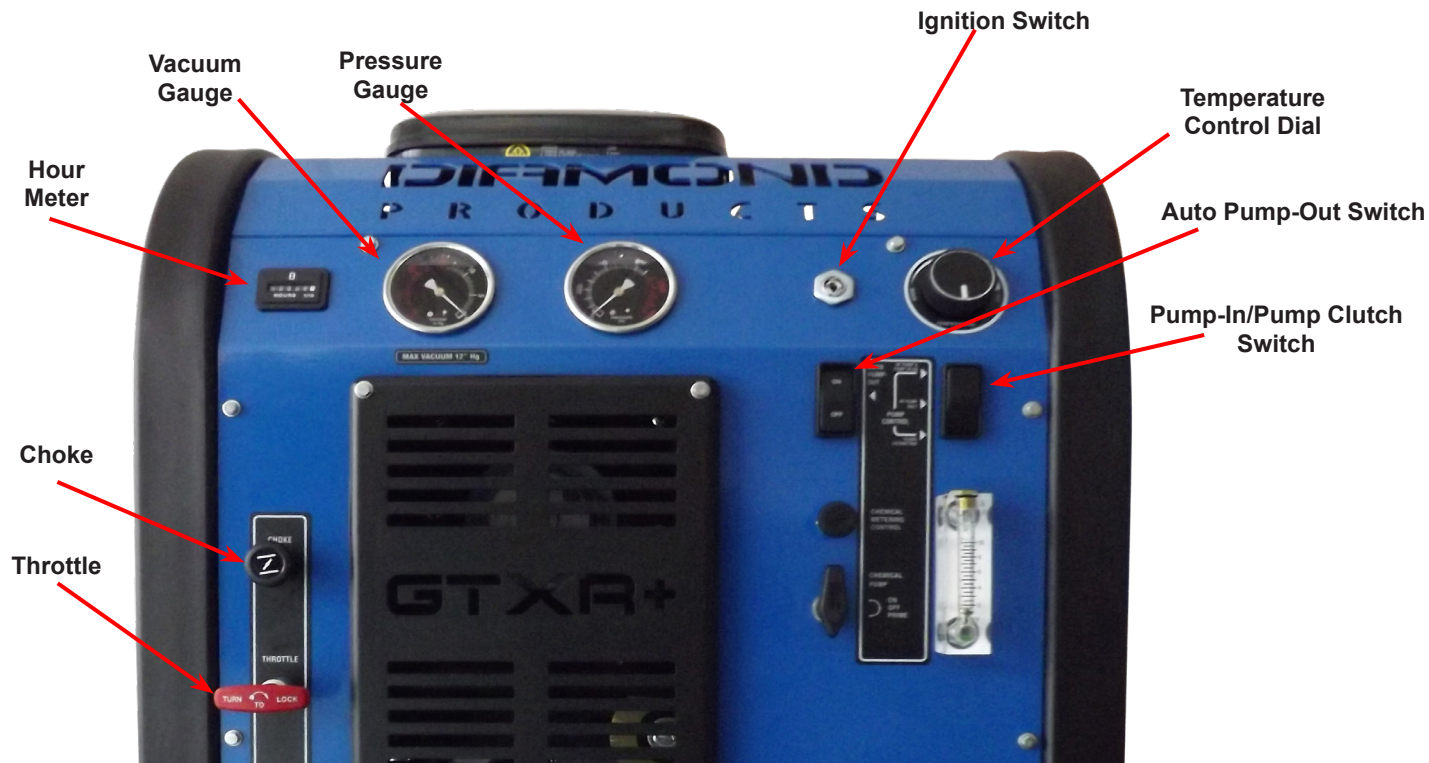

Figure 8-1. GTXR + Upper Dash Assembly

This section describes how to operate the GTXR +, starting with a description of the dash assembly (see Figure 4-1).

The front dash assembly includes controls for the:

- System's ignition switch
- Pump-Out system if included in the configuration
- Pump-In system if included in the configuration

The front dash assembly also includes the temperature control dial; the temperature, vacuum and pressure gauges; and the hour meter.

GTXR+



The lower dash houses the controls for:

Figure 8-2. GTXR + Lower Dash Assembly

- Water pressure
- Chemical system
- Water box drain

The lower dash assembly also houses the blower lube port and the solution out port where the wand/tool connects to the GTXR + (see Figure 4-2).

CAUTION

To ensure proper operation of the exhaust diverter system, the GTXR + must have a minimum of 10" Hg vacuum. If the vacuum level is lower than 10" Hg, the exhaust diverter will remain in "Divert" mode.

NOTICE

Photographs and illustrations included in this document can represent optional equipment as well as standard equipment.

CAUTION

Operating Instructions: 4-2

Never perform cleaning operations when the truckmount engine is running at

the IDLE throttle position. To do so will increase the risk of serious component or engine damage.

START UP PROCEDURE

1. Perform all daily periodic maintenance as specified in this Owner's Manual.
2. Connect a garden hose to supply water to the truckmount (see Figure 4-2). If the Pump-In feature is used on your system, push the "PUMP-IN SYSTEM" switch to the "ON" position.
3. Connect the cleaning wand or tool to the length of hose required to perform the cleaning job.
4. Start the truckmount with:
 - a. The "THROTTLE" cable in the "IDLE " position.
 - b. Pull the "CHOKE" cable out if the engine is cold.
 - c. The "PUMP CLUTCH" switch in the "OFF " position.
5. After the engine starts, allow the truckmount to run in "IDLE " for 2 - 3 minutes to warm up. Gradually push on the "CHOKE" as the engine warms up.

CAUTION

Never perform cleaning operation when the GTXR + is in the IDLE mode. Failure to follow this caution may result in serious component or engine damage.

6. Pull the "THROTTLE" cable all the way out and lock into place.
7. Press the "PUMP CLUTCH" switch to engage the pump clutch for carpet cleaning or upholstery cleaning as follows:
 - a. Switch to the "HP Only" if connected to a fresh water supply from a building.
 - b. Switch to the "HP On & Pump-In ON" if connected to a fresh water tank.
8. Set the "TEMPERATURE CONTROL" knob to the desired position.
9. If an automatic pump-out system option is included in your configuration, press the "PUMP-OUT" switch to the "ON" position.
10. Adjust the "PRESSURE REGULATOR", located on the left hand side of the machine, to the desired cleaning pressure level. Suggested Settings:
 - Carpet Cleaning: 300 - 400 psi
 - Hard Surface Cleaning: 1,000 psi or as indicated on the tool
11. Turn the "CHEMICAL SYSTEM" valve to the "PRIME" position to purge any air from the system (see Figure 4-3).
 - a. With the truckmount running at full throttle, block off the vacuum intake to the recovery tank. The vacuum gauge should read 14" Hg. This will assist in priming the chemical system.

GTXR+

- b. Allow the chemical to flow through the CHEMICAL METER at full flow for 30 seconds.
- c. Turn the “CHEMICAL SYSTEM” valve to “ON.” The restriction can now be

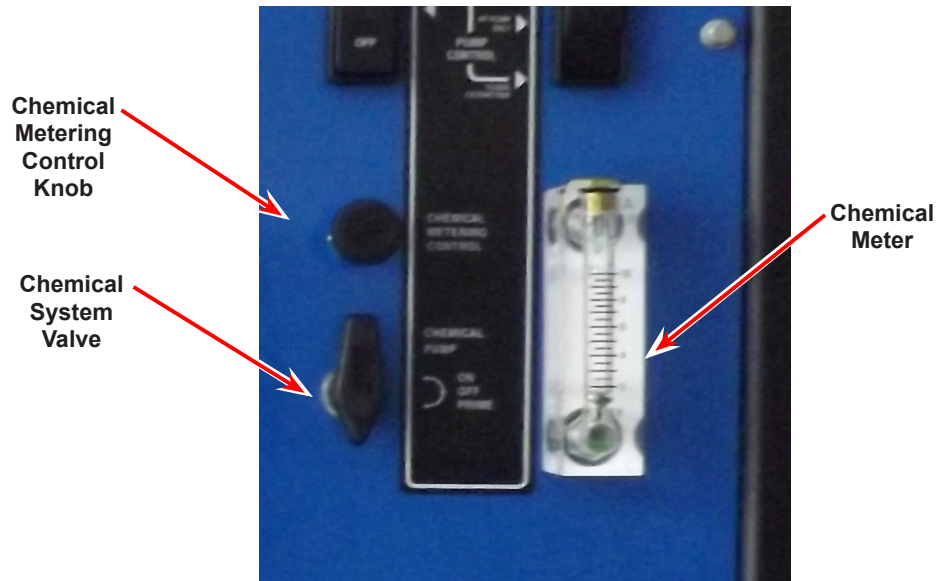

Figure 8-3. GTXR + Chemical System Control and Metering

- removed from the vacuum inlet.
- d. While spraying solution from the cleaning tool, adjust the chemical flow by turning the “CHEMICAL METERING CONTROL” knob.
12. Begin cleaning.

WATER EXTRACTION PROCEDURE

To perform water extraction, set the “PUMP CONTROL” switch to the Flood Extraction position. This will disengage the pump clutch, allowing for the machine to run without fresh water connected to it.

SHUT DOWN PROCEDURE

1. Flush clean water through the chemical system for 10 seconds. Turn the “CHEMICAL SYSTEM” valve to “OFF”.
2. Cool the truckmount down by turning the “TEMPERATURE CONTROL” dial to the lowest position (counter-clockwise). Spray the cleaning wand into the vacuum hose for 3-5 minutes. The chemical should now be flushed from the truckmount, hoses and cleaning tool.
3. Remove the vacuum hose.
4. Lubricate the blower to prevent it from rusting internally.
 - a. Allow the unit to run for a few minutes with the vacuum hose disconnected in order to remove moisture from the blower.
 - b. Cap off the inlet(s) to the recovery tank.
 - c. Spray a HydraMaster-recommended spray lubricant into the “BLOWER LUBE PORT” for about 5 to 7 seconds while the unit is running (see Figure 4-2).
 - d. Allow machine to run additional 2 to 5 minutes under load to flush off lubricant.
 - e. Uncap the inlet(s) and run the unit for another minute to allow the blower to cool down.
5. If freeze guarding is necessary, perform the procedure at this time. See the Freeze Guarding section of this Owner’s Manual (see page 5-18).
6. Push the throttle cable to the “IDLE ” position.
7. Turn the ignition switch to “OFF”.
8. Drain the water box using the water box drain valve (see Figure 4-2) .
9. Drain the recovery tank in an appropriate location.

NOTICE

In accordance with EPA, state and local laws, do not dispose of water into gutters, storm drains, streams or reservoirs.

10. Perform daily maintenance as specified in Section 5 of this Owner’s Manual.

GTXR+

5 - Machine Maintenance

To avoid costly repairs and downtime, it is imperative to develop and practice good maintenance procedures from the beginning. These procedures fall into daily, weekly, monthly and quarterly increments and are outlined in this section below. All recommended maintenance must be performed by qualified service personnel.

A maintenance log, provided in the Owner's Guide, must be correctly and completely filled out. HydraMaster may request to inspect the logs before a warranty claim is honored. It is recommended that the log be affixed to the vehicle door near the truckmount for convenience and to serve as a maintenance reminder.

This section describes how to properly maintain the truckmount in the following areas:

- Operational Maintenance
- Overall Machine Maintenance
- High Pressure Pump Maintenance
- Vacuum System Maintenance
- Descaling Procedure (Required)
- Freeze Guarding

GTXR+

OPERATIONAL MAINTENANCE

Daily Maintenance

- Check the engine oil level. Add oil if needed.
- Check the high pressure pump oil. Add oil if needed.
- Check the oil level in the blower. Add oil if needed.
- Inspect and clean the recovery tank filters.
- Inspect and clean the garden hose screen.
- Inspect the truckmount for water and oil leaks, loose electrical connections, etc. and repair as needed.
- Lubricate the blower lube port with a HydraMaster-recommended lubricant.

Weekly Maintenance

- Inspect the recovery tank filters for tears, holes, etc. Repair or replace as needed.
- Inspect the vacuum relief valve. Clean and lubricate as necessary.
- Clean the recovery tank thoroughly with pressure washer.
- Check the pump belt for wear and proper tension. Adjust as needed.
- Check all the hoses and wiring for wear and chafing. Secure as needed.
- Flush the water and chemical systems with solution of equal parts white vinegar and water.
- Check all the nuts and bolts. Tighten as needed.
- One time change of the high pressure pump oil after 50 hours of operation. (Every 500 hours thereafter.)
- One time change of the engine oil and oil filter after 5 hours of operation.
- Change the engine oil and oil filter every 50 hours. (Every 25 hours if operating in high ambient temperatures.)

Monthly Maintenance

- Check the engine air filter. Clean or replace as necessary.
- Check the water level in battery. Fill as needed.
- Clean the battery terminals as needed.

Quarterly Maintenance

- Check the fuel lines. Repair or replace as needed.
- Clean and gap the spark plugs to 0.030". Replace if excessive carbon buildup is visible.
- Check fuel filter. Replace as necessary.
- Change pump drive belt.

100 Hours

- Replace spark plugs every 100 hours.

- Change the blower oil after first 100 hours of use.

250 Hours

- Check coupler element (rubber insert) for cracks or wear. Replace as necessary.
- Check valve clearance, intake and exhaust 0.004 to 0.006" every 250 hours.

500 Hours

- Change blower oil.
- Change the high pressure pump oil.
- Change fuel filter.
- Check coupler element (rubber insert) for cracks or wear. Replace as necessary.

1,000 Hours

- Change air filters.
- Check plug wires. Replace as necessary.
- Check carburetor. Clean or replace as necessary.
- Clean the heat exchanger core.
- Replace coupler element (rubber insert).

NOTICE

Refer to the Interval in Hours Maintenance chart in the Owner's Guide for more information.

GTXR+

OVERALL MACHINE MAINTENANCE

Maintenance, troubleshooting and repair are much easier tasks to accomplish on a clean truckmount. Regular cleaning of the truckmount offers the user an opportunity to visually inspect all facets of the truckmount and spot potential problems before they occur. In addition to the operational maintenance the following “housekeeping” duties should be performed.

After each job

- Check the recovery tank and the recovery tank filters. Empty and clean as necessary.

Daily

- Wipe the truckmount down thoroughly with a damp cloth.
- Wipe down the vacuum and high pressure hoses as needed.
- Inspect and clean the vacuum slot on the cleaning wand.
- Check the wand head for sharp edges that could tear carpet. File down as needed.
- Clean the wand to maintain original appearance.
- Visually inspect the hoses for abrasions, cuts, etc. Repair or replace as needed.

Weekly

- Empty the chemical container. Wash out thoroughly to remove any chemical buildup.
- Inspect the chemical feed line strainer and use solution of equal parts white vinegar and water to remove any chemical buildup.
- Thoroughly clean the wand and inspect for clogged jets, debris in vacuum slot and leaking fittings at valve.
- Thoroughly clean the vacuum and high pressure hoses including quick releases and cuffs.

ENGINE MAINTENANCE

Engine Oil Level Check

The engine oil level should be checked daily. It is recommended that the oil be checked just before the engine is started for the first time for that day. The oil level should be between the 'Add' and the 'Full' marks on the dipstick.

CAUTION

Do not operate the engine with the oil level below the bottom of the 'Add' mark on the dipstick, or above the top of the 'Full' mark.

Adding Engine Oil

It is normal to add some oil in the period of time between oil changes. The amount will vary with the severity of operation. When adding or replacing engine oil, be sure the oil meets or exceeds the recommended specification.

Changing Engine Oil and Filter

The engine oil and filter must be changed every 50 hours or every 3 months whichever occurs first. The oil and filter should be changed more often if the engine is operating in dusty or extremely dirty areas, or during periods of high ambient temperature.

Engine Oil Quality

To achieve proper engine performance and durability, it is important that you use only engine lubricating oils of the correct quality in your engine. Proper quality oils also provide maximum efficiency for crankcase ventilation systems, which reduces pollution.

CAUTION

Use only engine oils displaying the American Petroleum Institute (API) "starburst" certification mark 'FOR GASOLINE ENGINES' on the container.

Engine Oil Recommendation

While multi-viscosity oils are generally recommended, SAE 5W-30 synthetic is specifically recommended year round for your GTXR + engine.

GTXR+

Oil Filter

Briggs and Stratton engines use Briggs and Stratton oil filters. An equivalent or better oil filter must be used when servicing the engine.

To replace the filter, use a proper filter wrench to remove the filter.

Clean the filter mounting base and lightly coat the gasket surface of the new filter with engine oil. Hand tighten the filter until the gasket contacts the base, then tighten another ½ turn. Fill the engine with the correct amount of oil, run the engine and check for oil leaks at the drain plug and oil filter gasket.

Spark Plugs

Always use the recommended spark plugs for your engine. Hotter or colder plugs, or similar plugs that are not exact equivalents to the recommended plugs, can cause permanent engine damage, reduce the engines useful life, and cause many other problems such as hard starting, spark knock and run-on. Installing new spark plugs regularly is one of the best ways to keep your engine at peak performance.

Fuel Filter

The fuel filter is located between the fuel pump and the fuel tank underneath the vehicle.

HIGH PRESSURE PUMP MAINTENANCE

Daily

Check the oil level and the condition of the oil. The oil level should be up to the center of the sight glass on the side or rear of the pump or between the “MIN” and “MAX” lines on the dipstick. The dipstick may be found by removing the oil cap.

Periodically

Change the oil after the initial 50 hours of operation and every 500 hours after that. It may be necessary to replace the pump seals and check valves at 500 hours if the truckmount has been running in high ambient temperatures.

Refer to the Pump Servicing Section starting on the following page for more information.

CAUTION

If the oil becomes discolored or contaminated one of the oil seals may be damaged. Do not operate the pump if the crankcase oil has become contaminated. Do not rotate the drive shaft without oil in the crankcase reservoir.

The pump should never be run dry. Running the pump dry will cause premature wear on the seals, packing and plungers. Running the pump dry for a prolonged period of time may cause damage that cannot be repaired and voids warranty.

Do not run the pump with frozen water in the manifold. If there is a risk of freezing, freeze guard the truckmount. See the Freeze Guarding section on page 5-18 of this manual.

GTXR+

Servicing Valves on the High Pressure Pump

Removing a Valve

1. Remove the valve cap (30 mm) and extract the valve assembly (see Figure 5-1).



Figure 8-1. Remove Valve Cap and Valve Assembly

2. Remove the valve assembly (retainer, spring, valve plate, valve seat) from the valve cavity.
3. Remove the O-ring and support from the valve cavity.
4. Examine the O-ring and replace if there is any evidence of cuts, abrasion, or distortion.
5. Inspect the manifold for wear or damage (see Figure 5-2).
6. Inspect the old valves for wear or damage. Only one valve kit (P/N 000-078-521) is necessary to repair all the valves in the pump. (The kit includes new supports, O-rings, valve seat, valve poppet, spring and retainer; all are pre-assembled.)

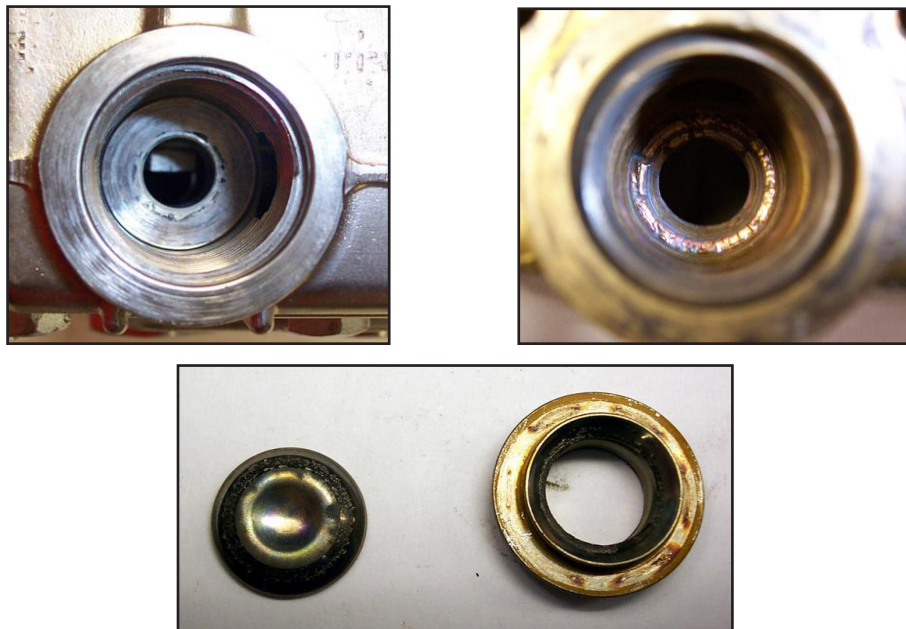

Figure 8-2. Inspect Manifold and Old Valves

7. Replace the center inlet check valve with a modified check valve - Figure 5-3.

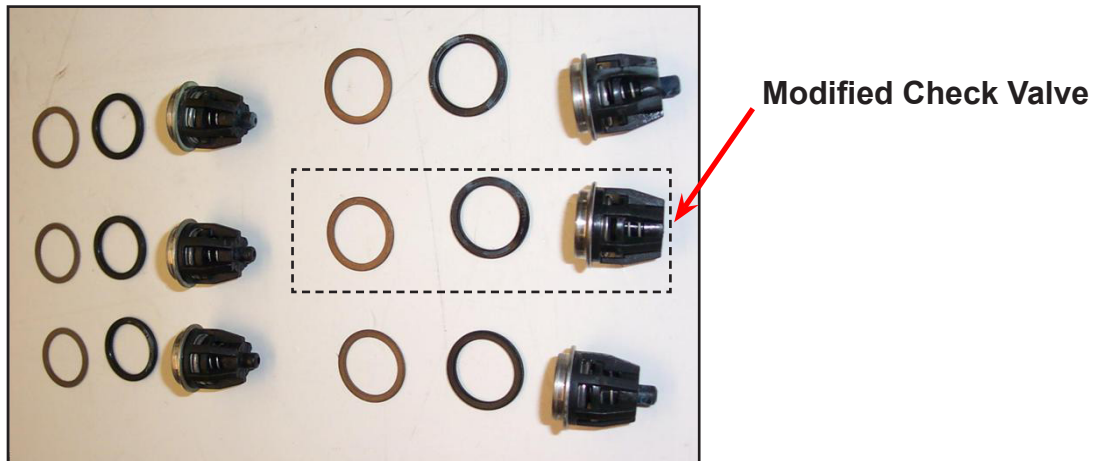

Figure 8-3. Replace Center Inlet Check Valve With Modified Check Valve

8. Apply O-ring grease to O-rings and install valves (Figure 5-4).
9. Replace valve cap and torque to 95 ft lbs see Figure 5-5).

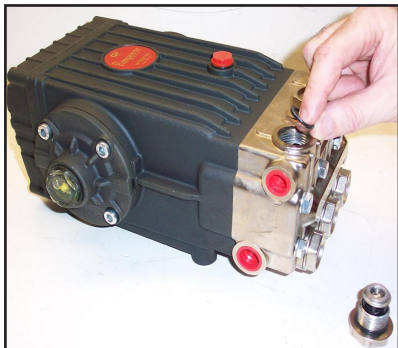

Figure 8-4. Apply Grease and Install Valves

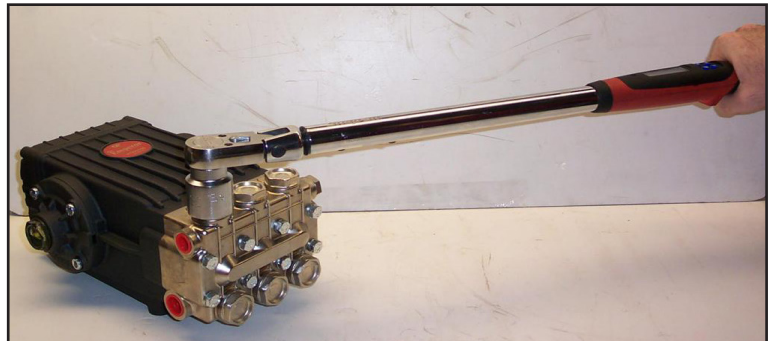

Figure 8-5. Replace Valve Cap and Torque to 95 ft lbs

GTXR+

10. Remove the fasteners retaining the manifold
11. Separate manifold from crankcase (see Figure 5-6).

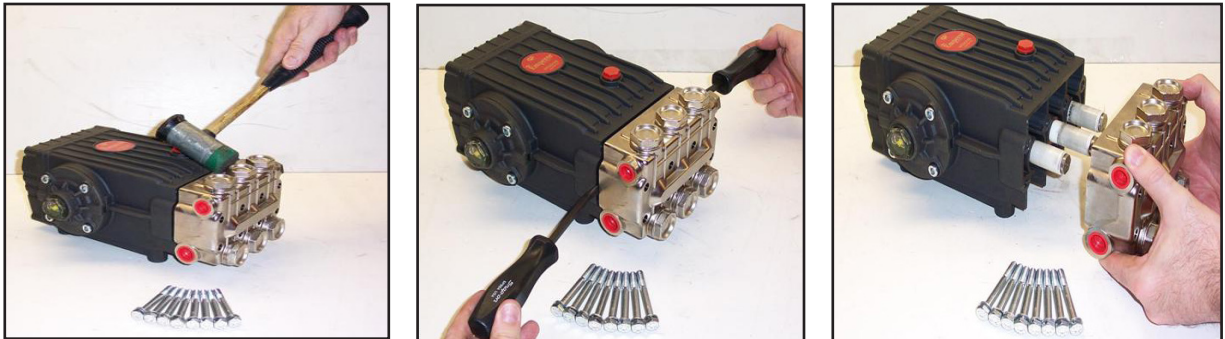

Figure 8-6. Separate Manifold from Crankcase

NOTICE

It may be necessary to rotate crankshaft or tap manifold with rawhide or plastic mallet to loosen.

CAUTION

When sliding manifold from crankcase, use caution not to damage ceramic plungers.

12. The seal assemblies may come off with the manifold (see Figure 5-7)

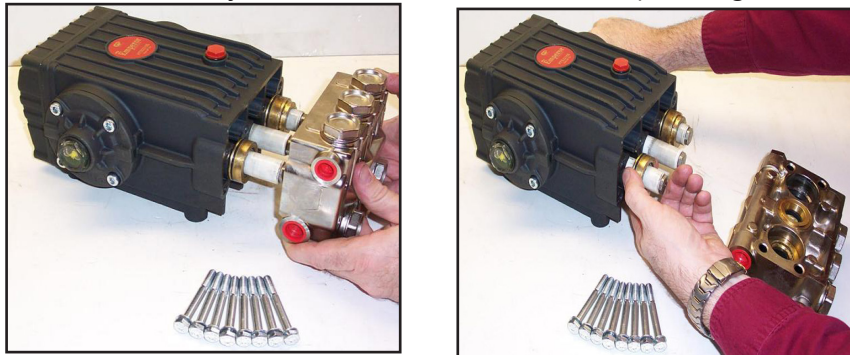

Figure 8-7. Seal Assemblies May Come Off with Manifold

13. Examine the ceramic plungers. The surface should be smooth and free from scoring, pitting or cracks (see Figure 5-8); if not, replace.
14. Loosen the stainless steel plunger bolt.



Figure 8-8. Examine Ceramic Plungers

15. Remove the stainless steel plunger bolt and ceramic plunger from the plunger guide (see Figure 5-9).
16. If the slinger washer is removed, be certain it is re-installed or replaced.
17. Separate plunger bolt from ceramic plunger (see Figure 5-9).

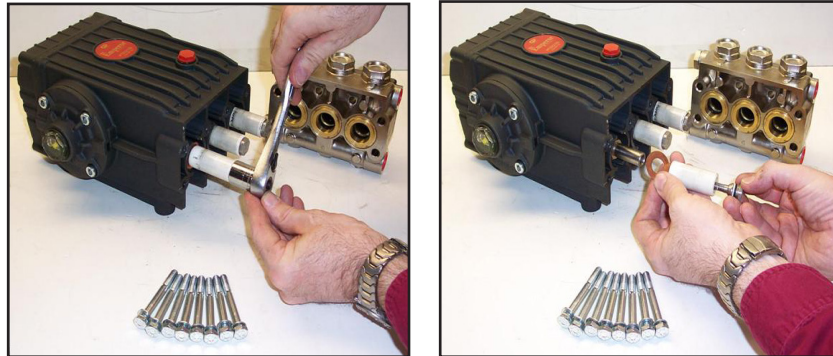

Figure 8-9. Remove Stainless Steel Plunger Bolt and Ceramic Plunger

18. Install new Teflon® back-up ring and O-ring on the plunger bolt. Apply a film of O-ring grease on the outside of the O-ring (see Figure 5-10).
19. Apply removable anaerobic thread sealant (Loctite® 542) to the threads of the plunger bolt, carefully pressing the plunger bolt into ceramic plunger (see Figure 5-10).
20. Slide new ceramic plunger over the plunger guide (see Figure 5-10).

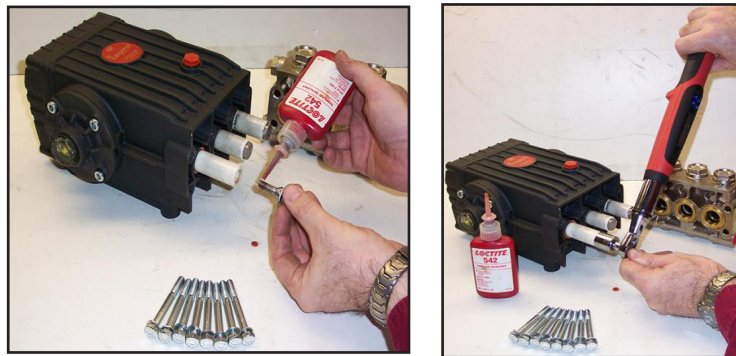

Figure 8-10. Install O-ring, Apply Sealant and Slide Plunger over Plunger Guide

21. Torque plunger to 14.5 ft lbs

GTXR+

Extracting Seals

With manifold removed from crankcase:

1. Insert proper extractor collet through main seal retainer (see Figure 5-11).
2. Tighten collet and extract retainers and seals.

NOTICE

The Teflon seals of the HT series will be damaged during disassembly so new ones will have to be installed.

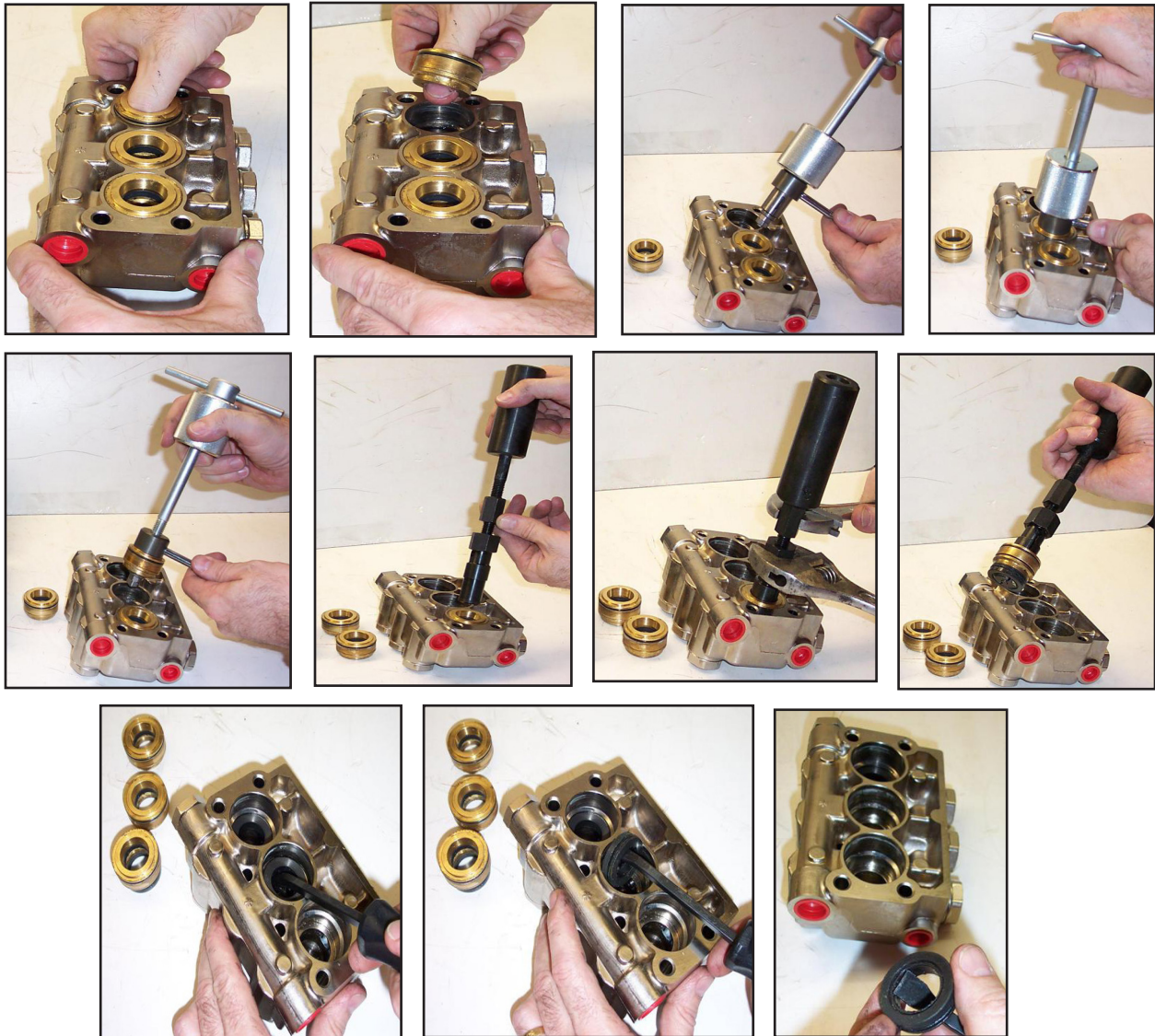

Figure 8-11. Extract Retainers and Seals

Replacing the Seal Assemblies

Only one seal kit is necessary to repair all the seals in the pump (see Figure 5-12). Use an insertion tool for seal installation

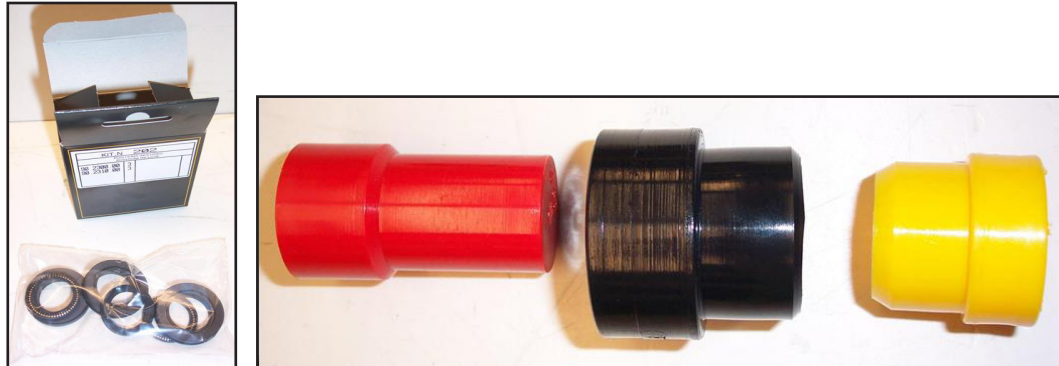

Figure 8-12. Seal Kit and Insertion Tool for Seal Installation

To install a seal assembly:

1. Apply a film of O-ring grease on the O-ring on the outside of the new high pressure seal.
2. Insert the high pressure seal into the cavity with the “U” shape down.
3. Press high pressure seal into place.
4. Apply a film of grease on the O-ring on the brass retainer (see Figure 5-13).

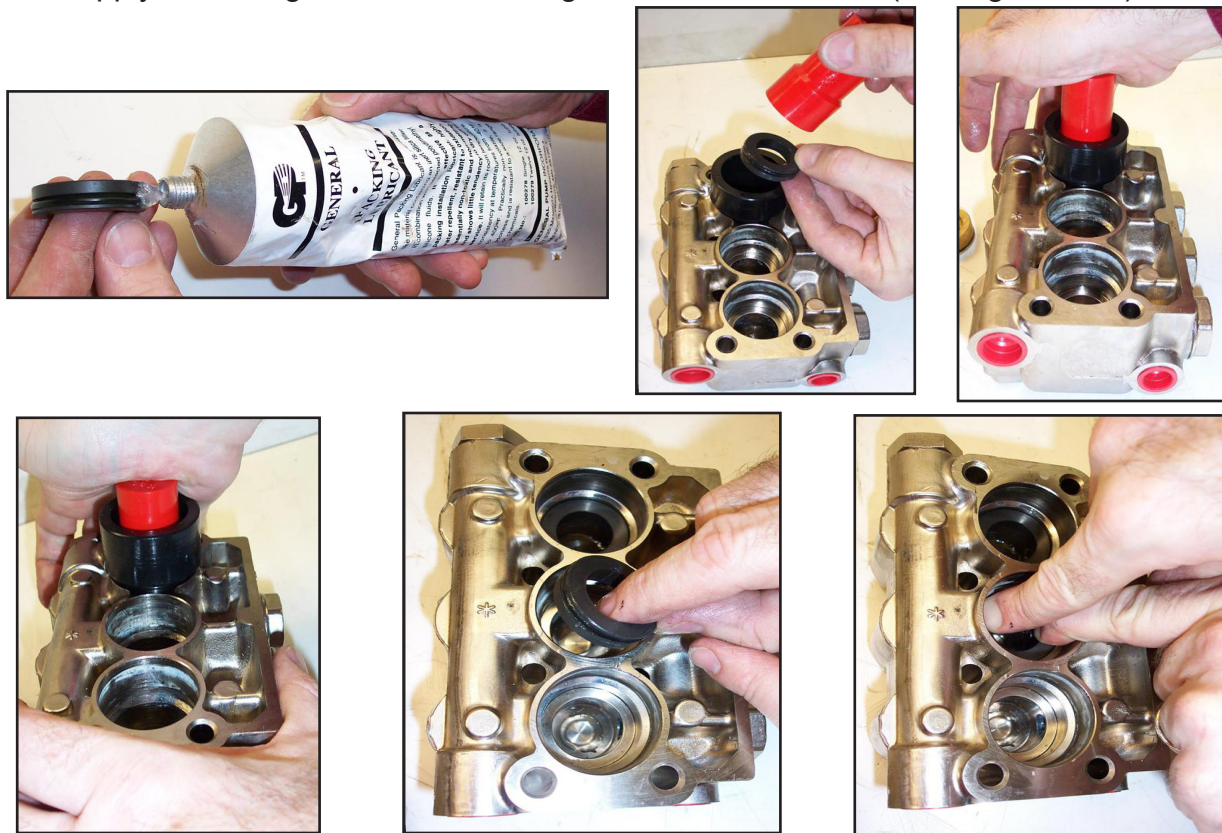

Figure 8-13. Install Seal Assembly Using O-Ring Grease

GTXR+

To install the intermediate retainers and the low pressure seals:

1. Insert the brass intermediate retainer into the cavity.
2. Press the new low pressure seal into the brass low pressure seal retainer and install a new O-ring on the outside (see Figure 5-14).

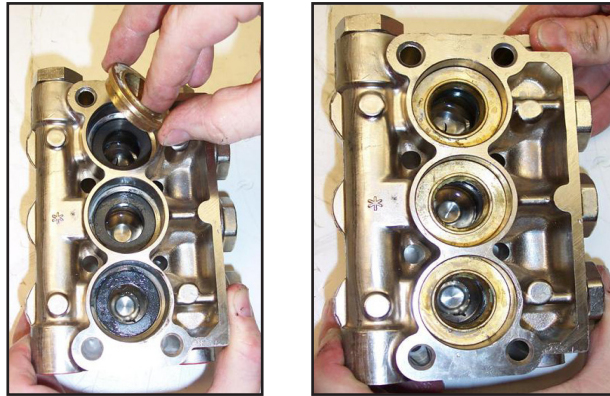

Figure 8-14. Install Retainers into Cavities

3. Press the low pressure seal assembly into the cavity (see Figure 5-15).

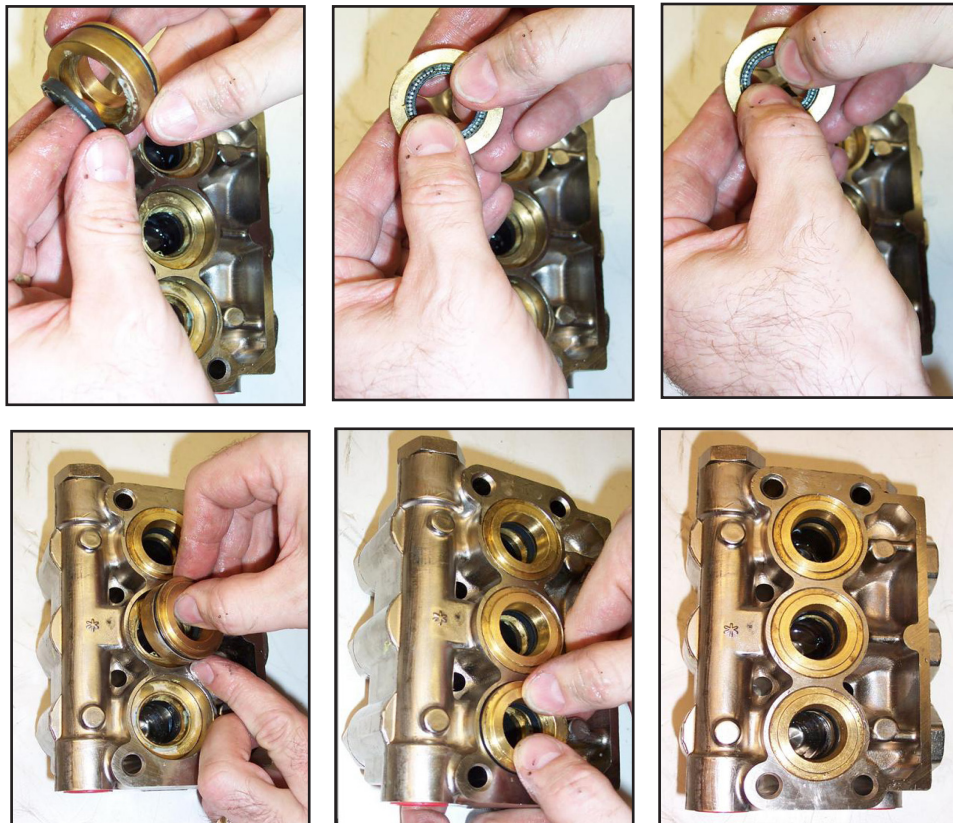

Figure 8-15. Press Low Pressure Seal Assembly into Cavity

Re-Installing Manifold

1. Position the outer plungers at the same position (see Figure 5-16).
2. Re-install manifold and torque the fasteners in an “X” pattern to 50% of specification and then retorque to 100% specification (see Figure 5-17 and Figure 5-18).

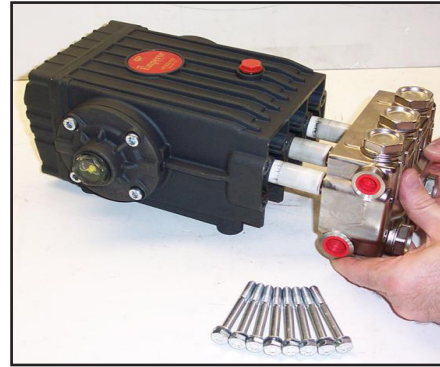
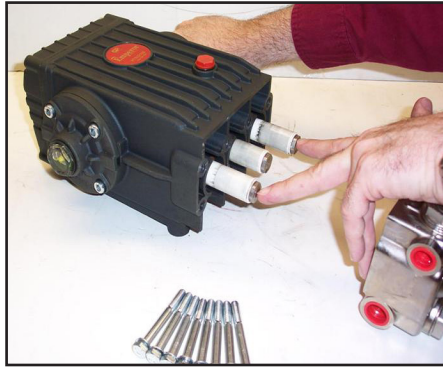
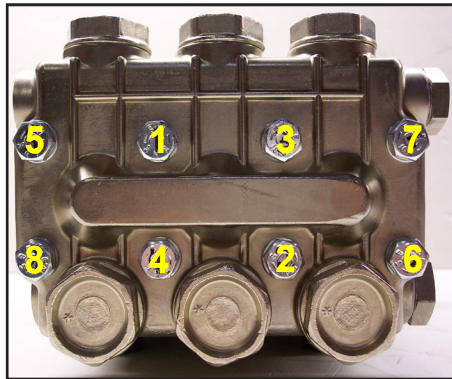
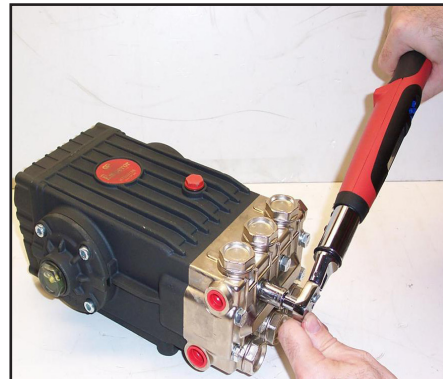

Figure 8-16. Re-install Manifold and Torque Fasteners



**Figure 8-17. Torque Sequence
in “X” Pattern**



**Figure 8-18. Torque Bolts to
22 ft. lbs**

GTXR+

VACUUM SYSTEM MAINTENANCE

The vacuum pump in this machine is commonly referred to as a “rotary positive displacement blower” or “blower” for short. The performance and life of the truckmount is greatly dependent on the care and proper maintenance it receives. The manual for the blower has been included. Review the manual for a better understanding of this piece of machinery.

CAUTION

To protect the blower from overloading and damaging itself, there is a vacuum relief system installed on the vacuum tank. When the vacuum tank inlet is completely sealed off a maximum of 12” Hg will be attained.

CAUTION

Solid objects entering the blower will cause serious damage to the internal components of the blower. Extreme caution should be used when the truckmount is being run for test purposes with the inlet to the blower open to the atmosphere.

CAUTION

Foam passing through the blower can lead to serious problems with the truckmount. It is important to keep the vacuum tank free of foam. The tank is protected from overflowing by a float kill switch; however, this switch is not activated by foam.

Daily

At the end of each day the internal components of the blower need to be lubricated. This helps to prevent rust deposits and prolongs the life of the truckmount.

To lubricate the blower:

1. Allow the unit to run for a few minutes with the vacuum hose disconnected in order to remove moisture from the blower.
2. Cap off the inlet(s) to the vacuum tank.
3. Spray a HydraMaster-recommended spray lubricant into the “BLOWER LUBE PORT” for about 5 to 7 seconds while the unit is running.
4. Uncap the inlet(s) and run the unit for another minute to allow the blower to cool down.

Periodically

Change the oil in both ends of the blower after the initial 100 hours of use. The oil is to be changed each 500 hours of use thereafter.

DESCALING PROCEDURE (REQUIRED)

Scale deposits on the interior of the heating system can cause a noticeable loss in heating performance. Deposits of this kind result from hard water. The frequency with which descaling procedures are required will vary. If the area has particularly hard water, you may have to descale often.

To descale the system, add an appropriate descaler chemical to the water box. Circulate it through the system. Let it stand. Flush and repeat as necessary. Clean all screens and strainers, and check them frequently following descaling.

NOTICE

If using TM DeScaler™ through the flow meter, make sure to run clean water through the flow meter after this procedure.

To descale using the recirculation kit (P/N 000-078-058), start with an empty water box. Fill a third of the water box with TM DeScaler™. Follow the recommendations on the TM DeScaler™ label for proportions. Verify that the float is not lying horizontal, but floats below.

Attach the recirculation fitting provided in the kit to the garden hose quick connect (see Figure 5-19) and this combination to the front of the truckmount.

Attach one section of the solution hose to the outgoing solution fitting on the front of the truckmount and the other end to the garden hose and recirculation fitting combination that is attached to the front of the truckmount. Additional hoses may be attached inline if descaling of hoses is needed.

Start the truckmount and allow it to run for 3 to 5 minutes. Do not leave the TM DeScaler™ solution in the system. Flush the system with clean water and turn the truckmount “OFF.”

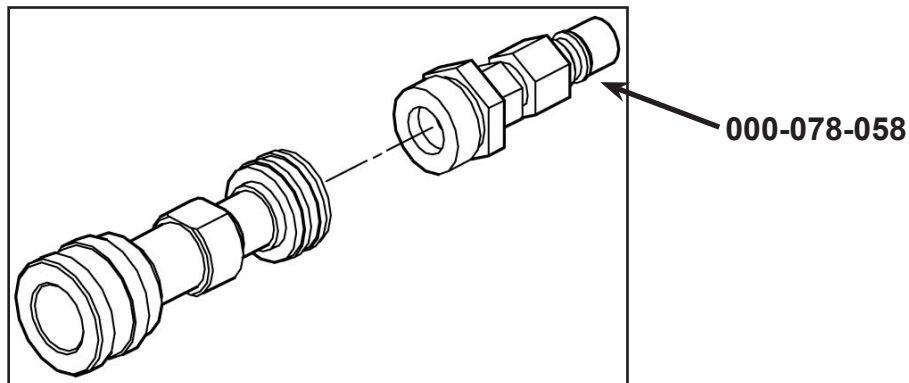

Figure 8-19. Recirculation Fitting

GTXR+

FREEZE GUARDING

To avoid permanent damage to the truckmount, it is imperative to follow the Freeze Guard Procedure whenever the possibility of freezing temperatures exists.

CAUTION

When disposing of antifreeze, follow local laws and regulations. Do not discard into storm sewers, septic systems or onto the ground.

⚠ WARNING

Antifreeze is harmful or fatal if swallowed. Do not store in open or unlabeled containers. Keep out of reach of children and animals.

⚠ WARNING

When draining solution from the machine, wear protective eye wear and ensure the solution temperature is cold. Failure to follow this caution can result in personal injury.

Freeze Guard Procedure

1. With the truckmount turned off and the incoming water line disconnected, open the water box drain valve on the front of the truckmount. Allow the system to fully drain.
2. Add 2 gallons of 50/50 antifreeze and water mix to the water box.
3. Attach a section of solution hose to the outgoing solution fitting on the front of the machine. Attach the opposite end to the recirculation fitting. (If more sections of hose are to be freeze guarded, attach those inline.)
4. Start the truckmount and allow it to run for 2 - 3 minutes. This will distribute antifreeze solution throughout the truckmount.
5. Remove the chemical feed line from the chemical jug. Turn the "CHEMICAL SYSTEM" valve to "PRIME." This will vacuum the chemical remaining in the lines to the recovery tank.
6. Remove the quick connect from the truckmount.
7. Spray the antifreeze and water mix out of the truckmount and into a container to reclaim the solution. Run the solution until it stops.
8. The truckmount is now freeze guarded. Remember to flush antifreeze from the system prior to carpet cleaning. See the following procedure.

NOTICE

The reclaimed antifreeze solution may be used three times before being discarded.

GTXR+

NOTICE

To freeze guard the hoses and wand, perform the preceding procedure with the items to be freeze guarded attached.

CAUTION

Always check the freezing level of your reclaimed antifreeze with a glycol tester before reusing. Failure to do so may result in serious component damage.

Recovering Antifreeze for Re-Use

1. Attach all hoses and wands which have been freeze guarded to the truckmount.
2. Attach the incoming water source to the front of the truckmount.
3. Start the truckmount.
4. Spray the solution through the hoses and wands into a sealable container until all signs of antifreeze are gone.

Freeze Protection of the Pump-In System

1. Drain the fresh water tank.
2. Remove the garden hose adapter from the pump-in pump hose and position the hose so it is pointing outside the van.
3. Turn on the pump-in pump and run for 1 - 2 minutes until all the water is purged from the hose.

NOTICE

The next time the truckmount is used, it may take a few minutes before the water box begins to fill.

6 - Water and Chemical System

This section describes the GTXR +' water and chemical systems, and includes the exhaust subsystem.

1. The process starts when fresh water is brought through the front of the truckmount into the water box, as indicated in Figure 6-1. The level of water in the box is maintained by the use of a float valve. The water is then gravity-fed to the pump where it is pressurized.
2. Next, the pressurized water enters the by-pass valve. This valve allows manual adjustment of the pressure level. When the valve at the wand is closed, the water in the system is recirculated to the water box. When solution is being used at the wand, the necessary amount of high pressure water passes through the by-pass valve and to the heat exchanger.
3. In the heat exchanger, the temperature is raised. The heat necessary to do this is provided by both the engine and blower exhausts. The heated water then travels to the high pressure manifold.
4. Water temperature is controlled via a temperature sensor inside the high pressure manifold. When the system achieves the maximum operating temperature, the high pressure solenoid opens and flows water into the recovery tank. This will reduce the internal temperature of the machine.
5. Water that is recirculated through the pressure regulator back to the water box travels past a thermal valve. This thermal valve monitors the water box temperature.
6. When the thermal valve senses the water in the water box has reached its set point, it opens the low pressure thermal valve on the side of the water box and closes once the temperature drops back below the set point (see Figure 6-2).
7. The water that is being called for by the wand then exits the manifold and passes through a check valve (see Figure 6-2).

GTXR+

Finally, the water joins the chemical where the solution is created (see Figure 6-2).

8. The chemical is pressurized by the HydraMaster diaphragm chemical pump attached to the head of the water pump. This pump pulls the chemical from the chemical, or soap, jug through the chemical flow meter (see Figure 6-3).
9. After being pressurized, the chemical travels through the metering valve and is injected into the high pressure stream. This solution then exits the front of the truckmount and is delivered to the cleaning tool.

Figure 8-1. Flow Diagram -
View 1 of 3
000-179-038 Rev. D

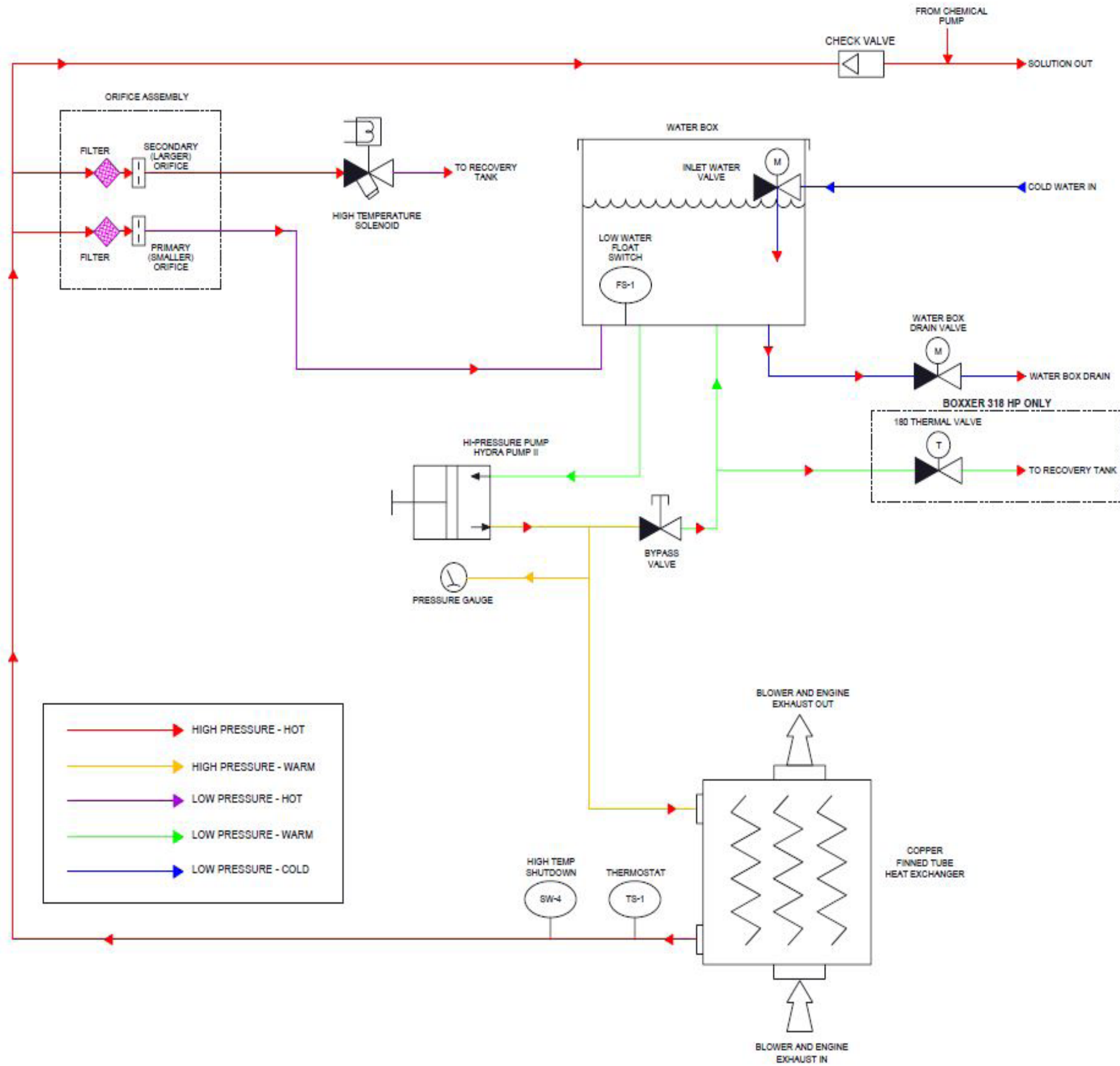

	HIGH PRESSURE - HOT
	HIGH PRESSURE - WARM
	LOW PRESSURE - HOT
	LOW PRESSURE - WARM
	LOW PRESSURE - COLD

G

Figure 8-2. Flow Diagram - View 2 of 3
000-179-038 Rev. D

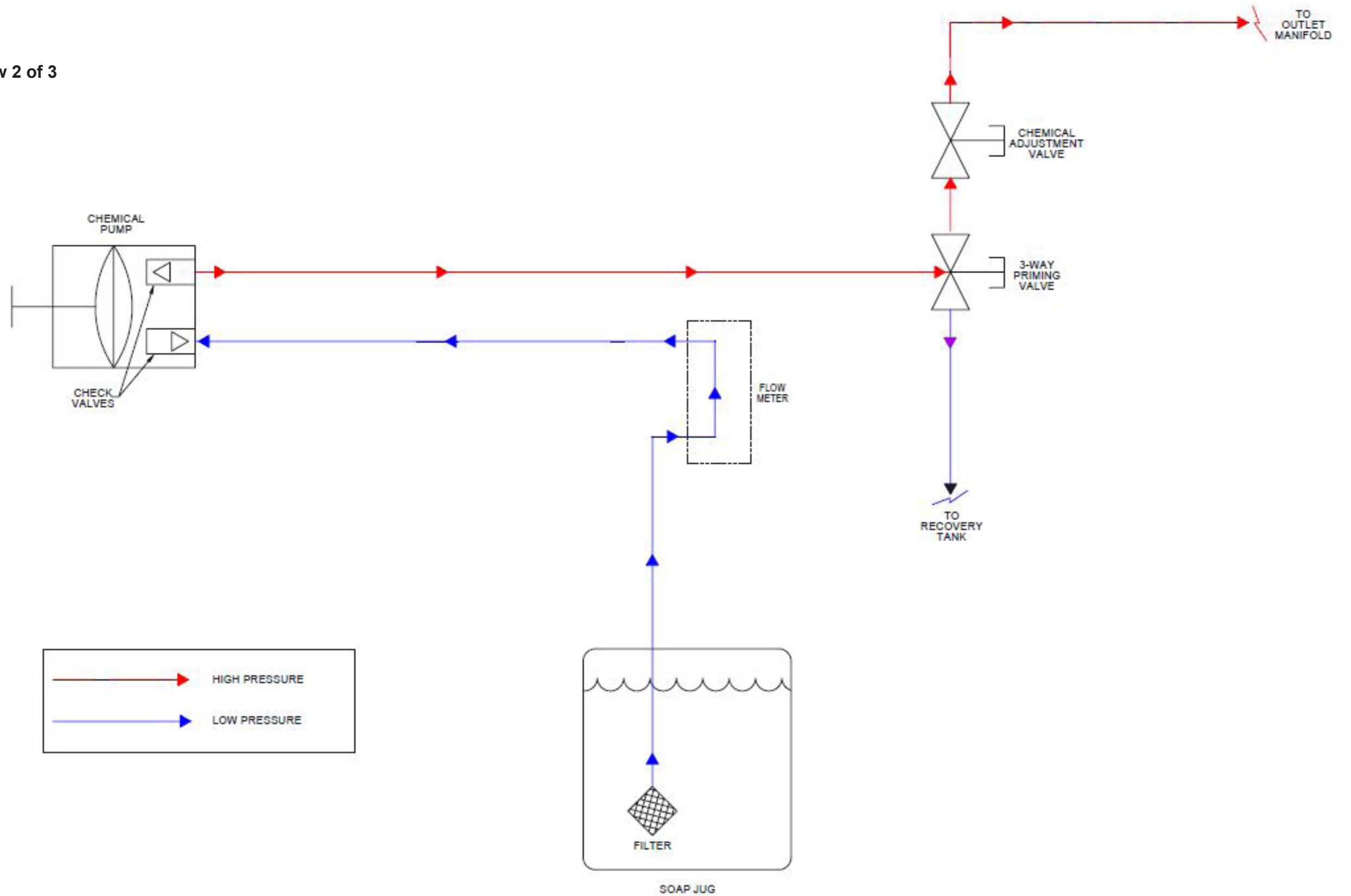
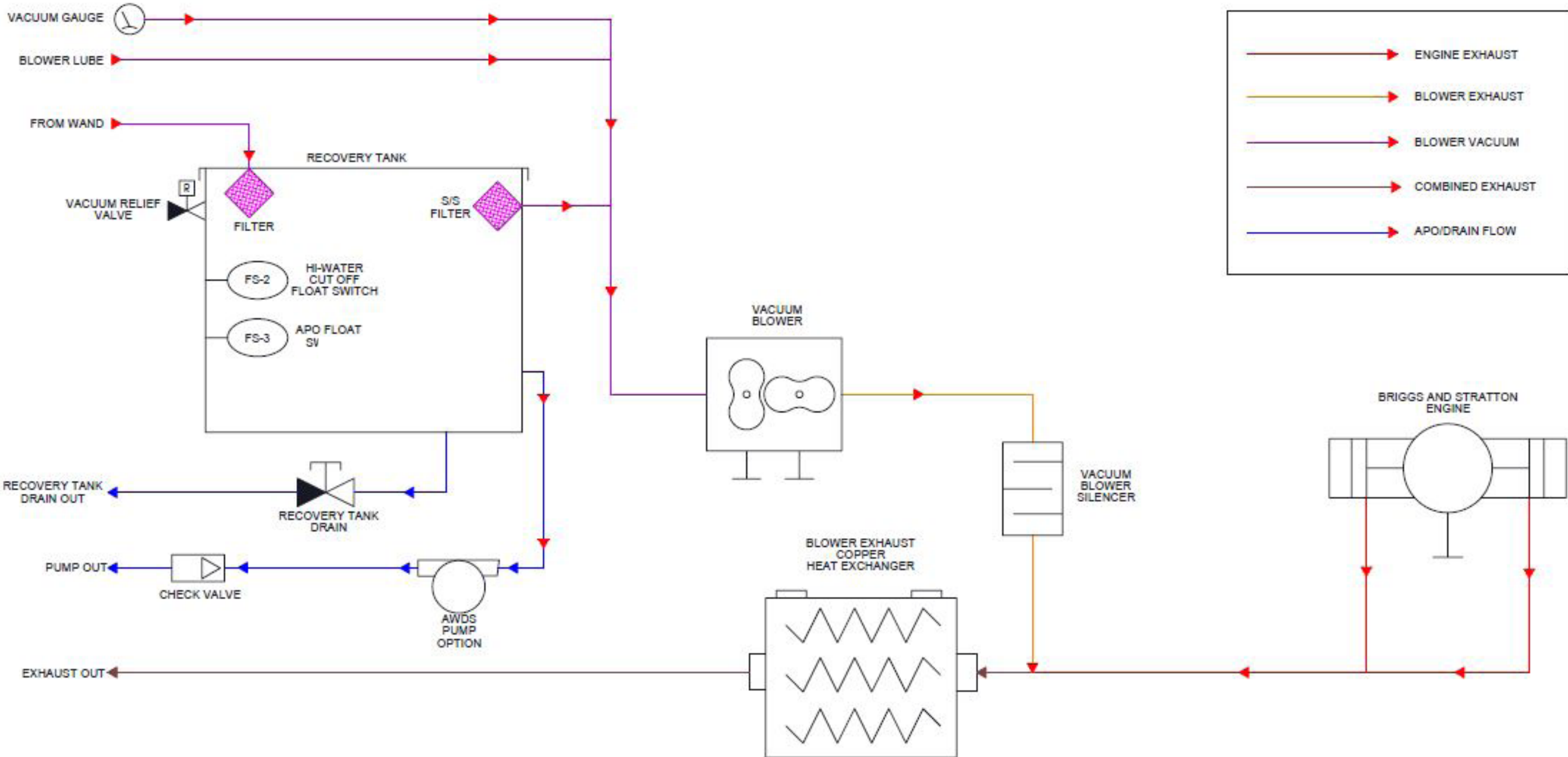

Figure 8-3. Flow Diagram - View 3 of 3
000-179-038 Rev. D



7 - Electrical System

This section describes how the electrical system functions in the following manner:

- Electrical System Information
- Electrical Schematic
- Wiring Diagram

ELECTRICAL SYSTEM INFORMATION

The GTXR + electrical system operates on 12 V DC which is provided by the battery. Battery levels are maintained by a 20 Amp alternator mounted on the engine.

NOTICE

When a new battery is installed, check that it is properly charged before installation or damage to the charging system may occur.

Figure 8-1. Electrical Schematic
000-179-048 Rev. B

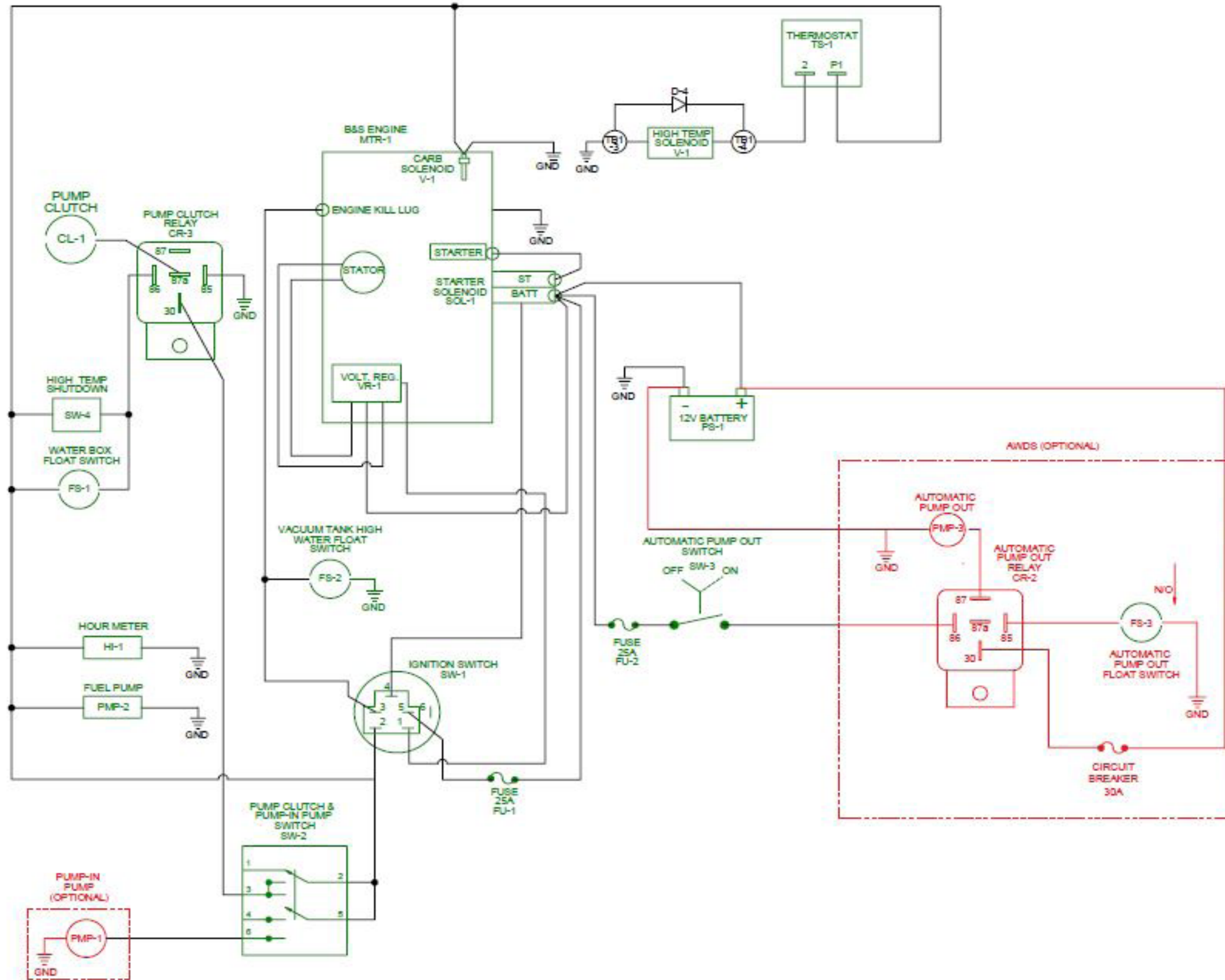

Figure 8-2. Wiring Diagram - View 1 of 2
000-179-047 Rev. C

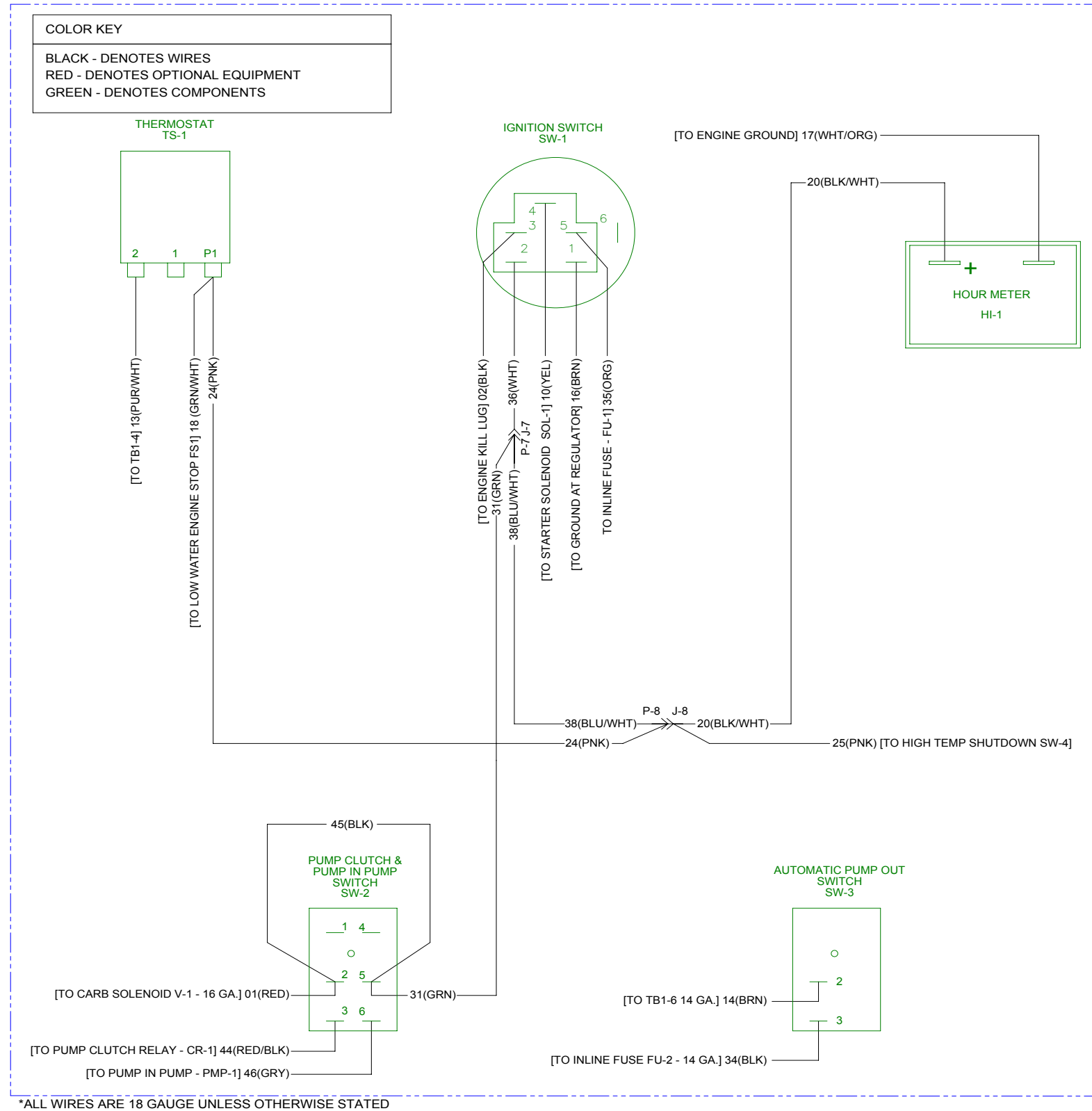
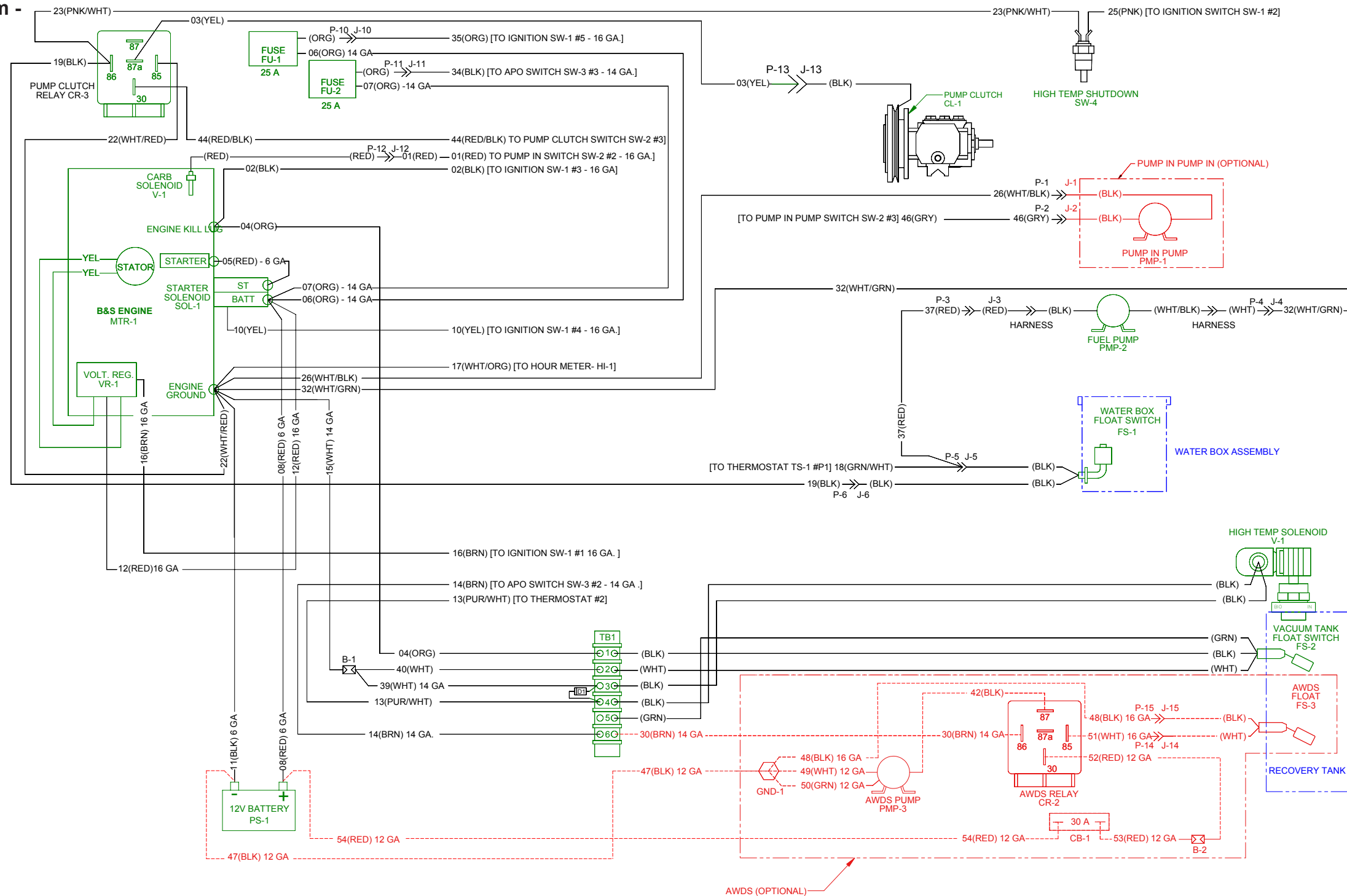

Figure 8-3. Wiring Diagram - View 2 of 2
000-179-047 Rev. C



COLOR KEY	
BLACK	- DENOTES WIRES
RED	- DENOTES OPTIONAL EQUIPMENT
GREEN	- DENOTES COMPONENTS

*ALL WIRES ARE 18 GAUGE UNLESS OTHERWISE STATED

8 - Systems Troubleshooting

This section describes the standard troubleshooting procedures in the following areas:

- Heating System
- Chemical System
- Engine
- High Pressure System
- Vacuum System

HEATING SYSTEM

1.0 Truckmount overheats and shuts down

Possible Cause		Solution
1.1	The orifice or filter screen is restricted.	Remove and inspect. Clean as necessary.
1.2	The dump solenoid is restricted.	Inspect the solenoid and the hose that delivers water to it. Clean or replace as necessary.
1.3	The dump solenoid is faulty.	Check the main fuse. If the fuse is blown, inspect electrical system for worn or shorted wires. Repair or replace as necessary.
		Inspect the solenoid and test for functionality. If the solenoid is operable, refer to a qualified service technician to test the temperature controller and sensor.

2.0 Unable to achieve normal cleaning solution temperature

Possible Cause		Solution
2.1	Temperature control knob is turned down.	Inspect the knob. Adjust if necessary.
2.2	The dump solenoid is faulty.	Inspect the solenoid and test for functionality. If the solenoid is operable, refer to a qualified service technician to test the temperature controller and sensor.
2.3	Excessive solution flow at tool.	The cleaning tool jet is too large or worn. Inspect the jet. Replace if necessary.
2.4	The heat exchanger has hard water scale buildup.	Descale the system.
2.5	The heat exchanger has blockage on the exhaust side.	Inspect the interior of heat exchanger. Remove the debris and clean as necessary.

CHEMICAL SYSTEM

1.0 System will not prime

Possible Cause		Solution
1.1	The check valves in chemical pump are faulty.	Remove the valves and inspect. Clean or replace as necessary.
1.2	The chemical pump diaphragm is faulty.	Remove and inspect. Replace as necessary.
1.3	The check valve in high pressure pump is faulty (piston which chemical pump is attached to).	Remove the valve and inspect. Clean or replace as necessary.
1.4	The filter on feed line in chemical jug is clogged.	Inspect and clean.
1.5	The feed line from chemical jug is loose, pinched or damaged.	Inspect and repair.
1.6	The chemical selector valve is faulty.	Inspect the valve for leaks between ports. Replace as necessary.

2.0 Chemical flow is unstable or low

Possible Cause		Solution
2.1	Air is in the lines.	Check that all fittings and connections are tight and in good condition. Repair or replace as necessary.
2.2	The filter screen in the chemical jug is partially obstructed.	Inspect and clean.
2.3	The chemical selector valve is faulty.	Inspect the valve for leaks between ports. Replace as necessary.
2.4	The chemical metering valve is faulty.	Remove and inspect the valve. Clean or replace as necessary.
2.5	The high pressure check valve is faulty.	Remove and inspect the valve. Clean or replace as necessary.

3.0 Chemical is present in water box

Possible Cause		Solution
3.1	The chemical pump diaphragm is faulty.	Remove and inspect the chemical pump diaphragm. Replace as necessary.
3.2	The high pressure check valve is faulty.	Remove and inspect the valve. Clean or replace as necessary.

ENGINE

1.0 Will not turn over

Possible Cause		Solution
1.1	A loose or corroded battery terminal.	Clean and tighten the battery terminal connections.
1.2	The battery is dead.	Recharge or replace the battery. Test the charging system. Repair if necessary. CAUTION Do not attempt to jump start the truckmount from a running vehicle. The amperage output from an automobile will damage the charging system of the truckmount.
1.3	The main fuse is blown.	Check the main fuse.
		If the fuse is blown, inspect the electrical system for worn or shorted wires. Repair or replace as necessary.
1.4	The vacuum blower has seized.	Attempt to turn the coupler by hand. If it will not turn refer to the Vacuum System Troubleshooting Section.
1.5	The ignition switch is faulty.	Test to see if there is power both to and from the switch. Refer to the Electrical Section.
1.6	The starter solenoid is faulty.	Test to see if there is power to solenoid with ignition in "Start" position. Refer to Electrical Section.
1.7	The starter motor is faulty.	Test to see if there is power to the motor with the ignition in "Start" position. Refer to the Electrical Section.
1.8	None of the above.	Refer to a qualified service technician for further troubleshooting.

2.0 Turns over but will not start; there is no spark. (To check for spark, refer to engine manual.)

Possible Cause		Solution
2.1	The recovery tank is full.	Drain the tank.
2.2	The recovery tank float is faulty.	Inspect the float. Repair or replace as necessary.
2.3	The engine ignition system is faulty.	Refer to a qualified service technician for further troubleshooting.
2.4	The water box is empty	Attach an inlet garden hose to fill the water box. <div style="background-color: yellow; padding: 5px; text-align: center;">CAUTION</div> If too many attempts are made to start the engine prior to filling the water box, it is possible to flood the engine (see step 3.3 in the next section)..

3.0 Turns over but will not start; there is spark. (To check for spark, refer to engine manual.)

Possible Cause		Solution
3.1	Fuel is not reaching the carburetor.	Test for power to the fuel pump. Refer to Electrical Section.
		If power is present, inspect the fuel pump. Replace if necessary.
		Inspect the fuel lines between the source and the carburetor. Repair or replace as necessary.
3.2	The carburetor solenoid is faulty.	Test for power to the solenoid. Refer to Electrical Section.
		If power is present, inspect the solenoid. Replace if necessary.
3.3	The engine is flooded.	Pull the throttle cable completely and crank until the engine starts.
3.4	The spark plugs are worn or dirty.	Inspect and replace as necessary.
3.5	None of the above.	Refer to a qualified service technician for further troubleshooting.

4.0 Will not come up to normal operating rpm. Note: engine should be adjusted to run at 3,200 rpm under no vacuum load.

Possible Cause		Solution
4.1	The throttle linkage is out of adjustment.	Inspect for broken or loose linkage. Repair or replace as necessary.
4.2	Excessive load on the engine.	Inspect and clean the recovery tank filters.
		Inspect the recovery tank to the blower hose. Repair or replace as necessary.
4.3	Excessive back pressure on the engine exhaust.	Inspect for blockage in the heat exchanger. Clean or replace as necessary.
4.4	The air filter is dirty.	Inspect and replace as necessary.

5.0 Runs rough at high speed

Possible Cause		Solution
5.1	The spark plug(s) are faulty.	Remove and inspect the plugs. Clean or replace as necessary.
5.2	The spark plug wire(s) are faulty.	Inspect the wires and connectors for damage or loose connections. Repair or replace as necessary.
5.3	Inadequate fuel supply to the carburetor.	Check if the fuel pump is mounted in a vertical position near the fuel source. Correct if necessary.
		Check for blockage in the filter. Repair or replace as necessary.
		If operating altitudes have changed, contact your distributor to have the engine carburetor jets checked.

6.0 Runs rich. (Black smoke)

Possible Cause		Solution
6.1	The air filter is dirty.	Inspect and replace as necessary.
6.2	The choke is partially closed.	Inspect and adjust or repair as necessary.
6.3	Excessive fuel to the carburetor.	Check to see if the proper fuel pump is installed.
		If operating altitudes have changed, contact your distributor to have the engine carburetor jets checked.

7.0 Engine overheats

Possible Cause		Solution
7.1	Poor ventilation in the van.	Open all the van doors.
		Install a roof vent in the van.
		Remove any dividers or other objects impeding airflow around the truckmount.
7.2	Low oil level.	Check the level and fill as necessary. <div style="background-color: yellow; padding: 5px; text-align: center;">CAUTION</div> Running the engine with a low oil level can cause severe damage to the engine. If this situation occurs, the engine should be inspected by a qualified service technician.
7.3	The engine rpm is too high.	Check the engine rpm. Adjust as necessary to run at 3,200 rpm under no vacuum load.
7.4	Excessive back pressure on the engine exhaust.	Inspect for blockage in the heat exchanger. Clean or replace as necessary.

HIGH PRESSURE SYSTEM

1.0 The pump will not come up to normal cleaning pressure

Possible Cause		Solution
1.1	The pressure adjusting valve is faulty.	Inspect the valve. Repair or replace if necessary.
1.2	Worn seals or valves in the pump.	Test the pump output volume directly from the pump at normal running rpm. If the volume is below the manufacturer's specifications, replace the seals and inspect for defective valves.
1.3	The pump rpm is too low.	Check for a loose pump belt. Adjust or replace as necessary.
		Check the engine rpm and adjust as necessary to 3,200 rpm under no vacuum load.
1.4	The primary orifice is missing or loose.	Remove and inspect. Tighten or replace as necessary.
1.5	The primary and secondary orifices have been installed incorrectly.	Inspect and reverse if necessary. Refer to the Machine Assemblies & Parts List Section.
1.6	The primary orifice is worn.	Measure the orifice size and replace as necessary. Correct size is 0.021".

2.0 No pressure reading on gauge

Possible Cause		Solution
2.1	The pump belt is broken.	Inspect and replace if necessary.
2.2	The gauge is faulty.	Replace the gauge.

3.0 The psi gauge reads normal; low pressure from wand

Possible Cause		Solution
3.1	Restriction in the cleaning tool.	Inspect the tool jet(s) and clean or replace as necessary.
		Inspect any filters in the cleaning tool and clean or replace as necessary.
3.2	Faulty quick connect in the system.	Inspect each quick connect and replace as necessary.
3.3	Restriction in one of the solution hoses.	Remove the quick connects and inspect hoses. Clean or replace as necessary.
3.4	Hard water deposits restricting the system.	Descale the truckmount.

4.0 Pressure pulsation

Possible Cause		Solution
4.1	Air leak between the water box and pump.	Check all the hoses and fittings for cuts, breaks, cracks, etc. Repair as necessary.
4.2	The check valve(s) in the pump are faulty.	Remove each valve and inspect for correct operation. See the Machine Maintenance Section.

5.0 Water box empty or fills slowly

Possible Cause		Solution
5.1	Restriction in the water supply system.	Inspect the supply system from the source through the incoming quick connect.
5.2	The float valve in the water box is faulty.	Disassemble and inspect the valve. Repair or replace as necessary.

6.0 The water box overflows

Possible Cause		Solution
6.1	The float valve in the water box is faulty.	Disassemble and inspect the valve. Repair or replace as necessary.
6.2	The float has absorbed water and lost buoyancy.	Detach the float and check to see if it will float to the surface. Replace as necessary.
6.3	The float has come out of adjustment.	Adjust the float as necessary.

VACUUM SYSTEM

1.0 A weak vacuum at wand. The gauge reads normal.

Possible Cause		Solution
1.1	Blockage in the hoses or wand tube	Disconnect the hoses and check for an obstruction.
1.2	Excessive length of hose connected to the truckmount	Do not attach excessive lengths of hose.

2.0 A weak vacuum

Possible Cause		Solution
2.1	Air leak somewhere in the vacuum system.	Check the vacuum relief valve for proper adjustment.
		Carefully check all the vacuum hoses for a cut or break.
		Check the recovery tank lid gasket.
		Make sure the recovery tank drain valve is fully closed.
2.2	The vacuum blower is turning too slowly.	Check the rpm of the engine. Adjust as necessary to 3,200 rpm under no vacuum load.
2.3	The vacuum gauge is defective.	Test the gauge and replace if necessary.

3.0 The vacuum gauge reads too high with no hoses attached

Possible Cause		Solution
3.1	The filter in recovery tank is clogged.	Remove and clean or replace as necessary.
3.2	The hose from recovery tank to the vacuum blower is collapsed internally.	Inspect and replace as necessary.

4.0 Excessive noise produced by the blower

Possible Cause		Solution
4.1	The blower is low on oil.	Inspect the oil levels and replenish as necessary. Note: Running the blower with low oil levels can cause severe damage. If this situation occurs the blower should be inspected by a qualified service technician.
4.2	The vacuum blower has internal damage.	Refer to a qualified service technician.

5.0 The vacuum blower is locked and will not turn

Possible Cause		Solution
5.1	Truckmount has been inactive for a period of time and the blower was not properly lubricated prior to final shutdown. Rust has possibly built up on the internal surfaces.	Spray penetrating oil into the blower and let sit for at least 1 hour. Then very carefully use pipe wrench on the outer diameter of the pulley on the coupler to attempt to free lobes of the blower. Do not use a wrench directly on the blower shaft.
		If unable to free up the blower in this manner, refer to a qualified service technician.
5.2	There is internal damage to the blower.	Refer to a qualified service technician.

6.0 Water in truckmount exhaust

Possible Cause		Solution
6.1	The recovery tank has been filled with foam or overfilled with water.	Inspect the recovery tank. If full, drain the tank.
		Inspect the high level shutoff switch for proper operation. Clean or replace the switch as necessary.
		If foam is in recovery tank, use defoamer on the carpet being cleaned.
6.2	Condensation in system.	This will be more common in cool weather and humid climates. If this is the cause, it should dissipate after a few minutes of running.
6.3	The heat exchanger is leaking water.	Inspect and repair or replace as necessary.

GTXR+

9 - Assemblies and Parts Lists

This section of the manual provides detailed illustrations and parts lists for the following assemblies.

NOTICE

When ordering parts for assemblies, first refer to the appropriate assembly listed here and then find the part number listed on that specific page. In most cases, you do not have to order the entire assembly to get a part.

If you have an electronic copy (a .pdf) of this Manual, you can search for the part number by pressing the **CTRL** key and the **F** key at the same time. This will “pop up” the Find window on your monitor. Type the part number, including dashes, into the Find window and press the **Enter** key.

- Adhesive and Sealant lists 9-2
- Console Assembly Parts List 9-9
- Frame Assembly Parts List 9-11
- Blower Assembly Parts List 9-14
- Silencer Assembly Parts List 9-15
- Engine Assembly Parts List 9-17
- Pump Assembly Parts List 9-19
- Blower Heat Exchanger Assembly Parts List 9-21
- Water Box Assembly Parts List 9-23
- Dash Assembly Parts List 9-26
- Differential Check Valve Assembly Parts List 9-27
- By-Pass Valve Assembly Parts List 9-29
- Hi-PSI Manifold Assembly Parts List 9-31
- Idler Pulley Assembly Parts List 9-32
- Exhaust Assembly Parts List 9-33
- 70 Gallon Universal Recovery Tank (URT) Assembly Parts List 9-35
- 70 Gallon Universal Recovery Tank (URT) Cover Assembly Parts List 9-37
- Vacuum Relief Valve Assembly Parts List 9-38
- 70 Gallon Fresh Water Tank Assembly Parts List 9-42
- Hose Routings 9-43

GTXR+

Some of the illustrations in this section reference sealants, thread lockers, adhesive, primer, anti-seize and lubricant specifications that are used in the construction of HydraMaster equipment.

Refer to Figure 9-1 to identify those substances such as A1, A2 and so forth. Equivalent products are acceptable if they meet or exceed current specifications and are approved by HydraMaster.

Adhesive Material Production Line Reference Card from ENG-45975 Rev. 0					
<p>A1 Silicone RTV</p> 	<p>A2 Loctite 567</p> 	<p>A3 Loctite 545</p> 	<p>A4 Teflon Tape</p> 	<p>E1 Loctite 51252 Grease</p> 	
<p>B1 Loctite 242</p> 	<p>B2 Loctite 262</p> 	<p>B3 Loctite 266</p> 	<p>C1 Gapper</p> 	<p>D1 Loctite 7649</p> 	<p>E2 Molykote Anti-Seize</p> 
<p>B4 Loctite 222MS</p> 	<p>B5 Loctite 425</p> 	<p>E4 Super Lube</p> 	<p>E5 SKF Anti-Fret</p> 		

Figure 8-1. Adhesive/Sealant Material Reference

Figure 8-2. Console Assembly - View 1 of 6
610-050-754 Rev. A

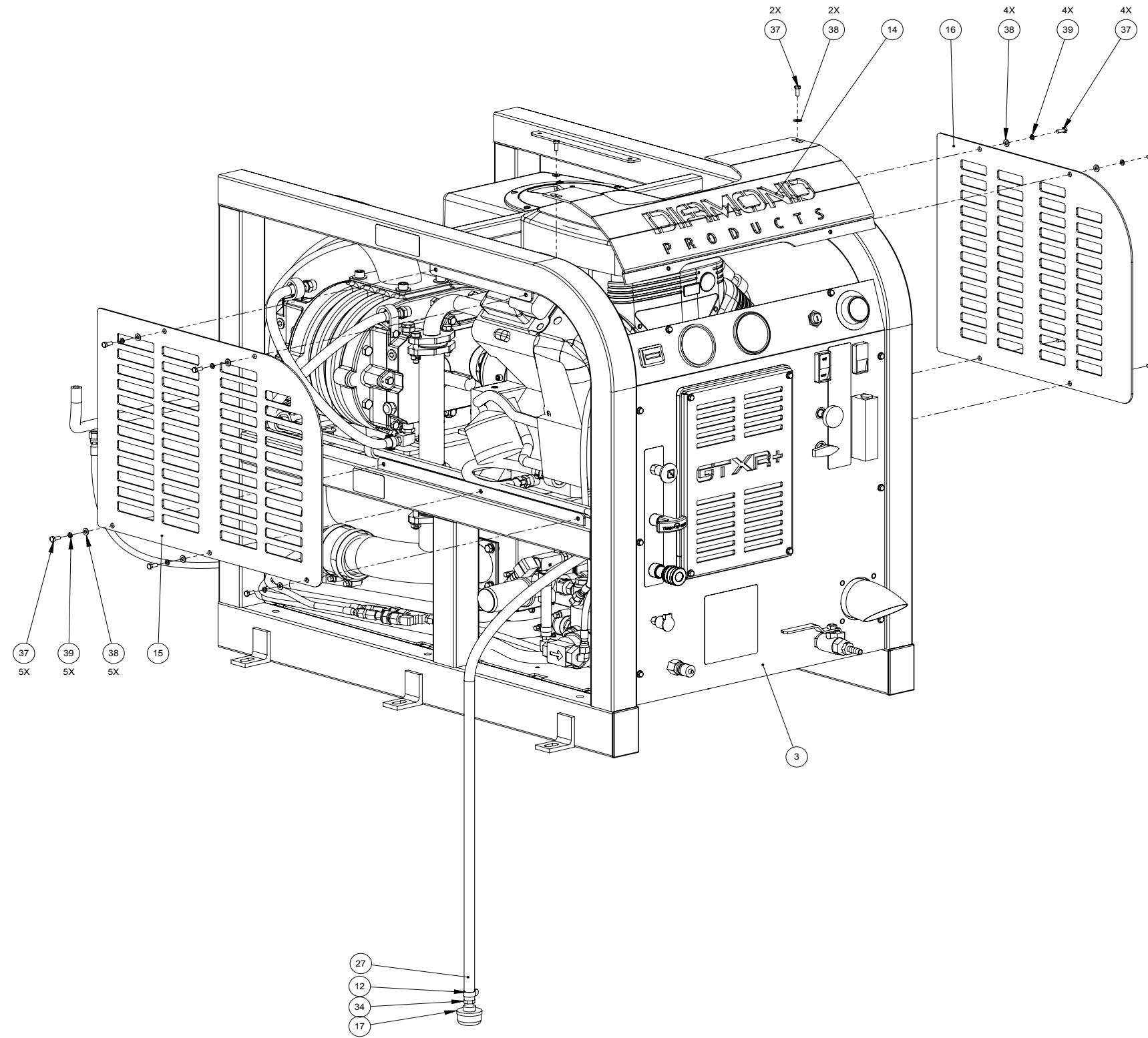

GTXR+

Figure 8-3. Console Assembly - View 2 of 6
610-050-754 Rev. A

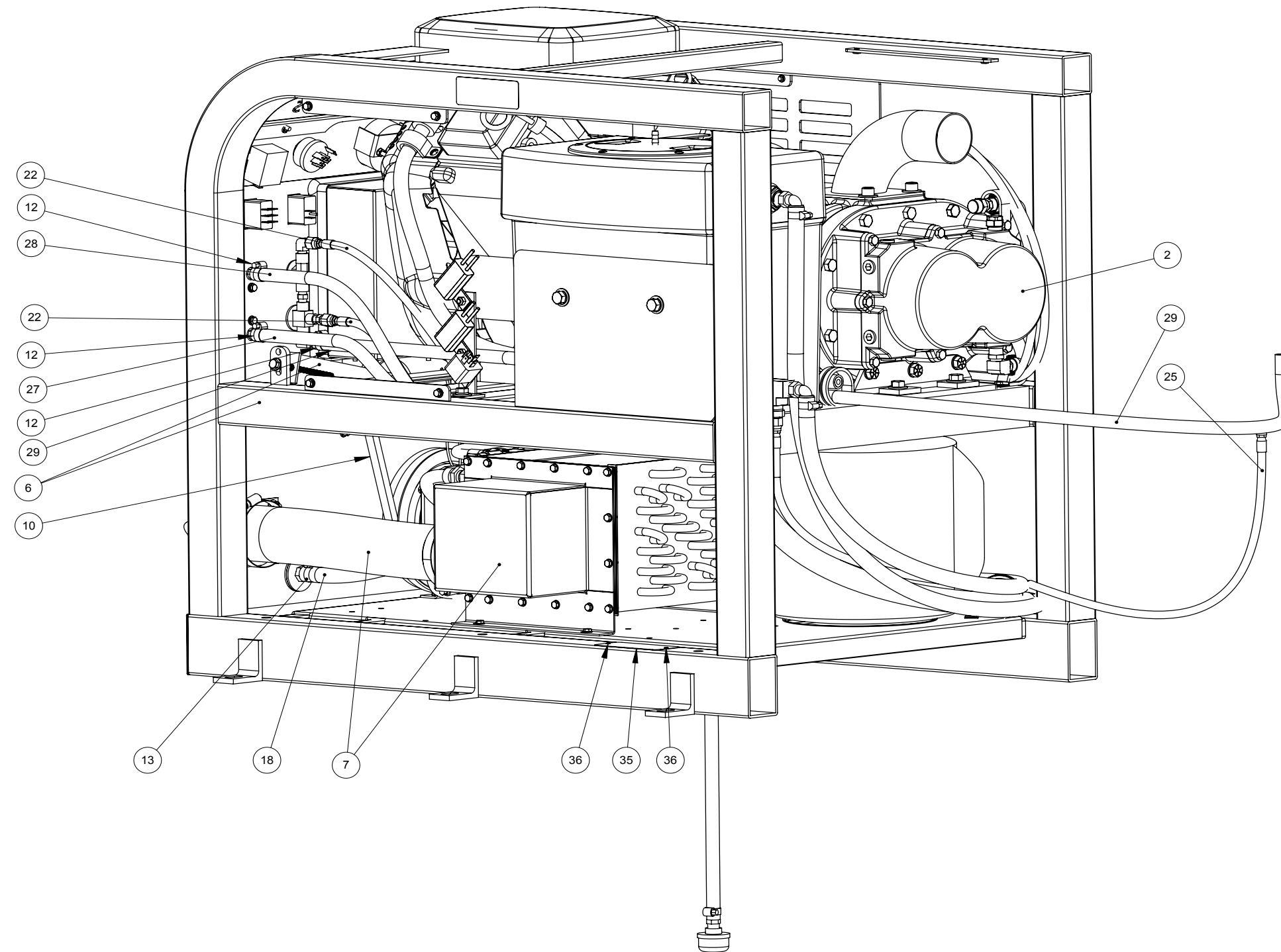
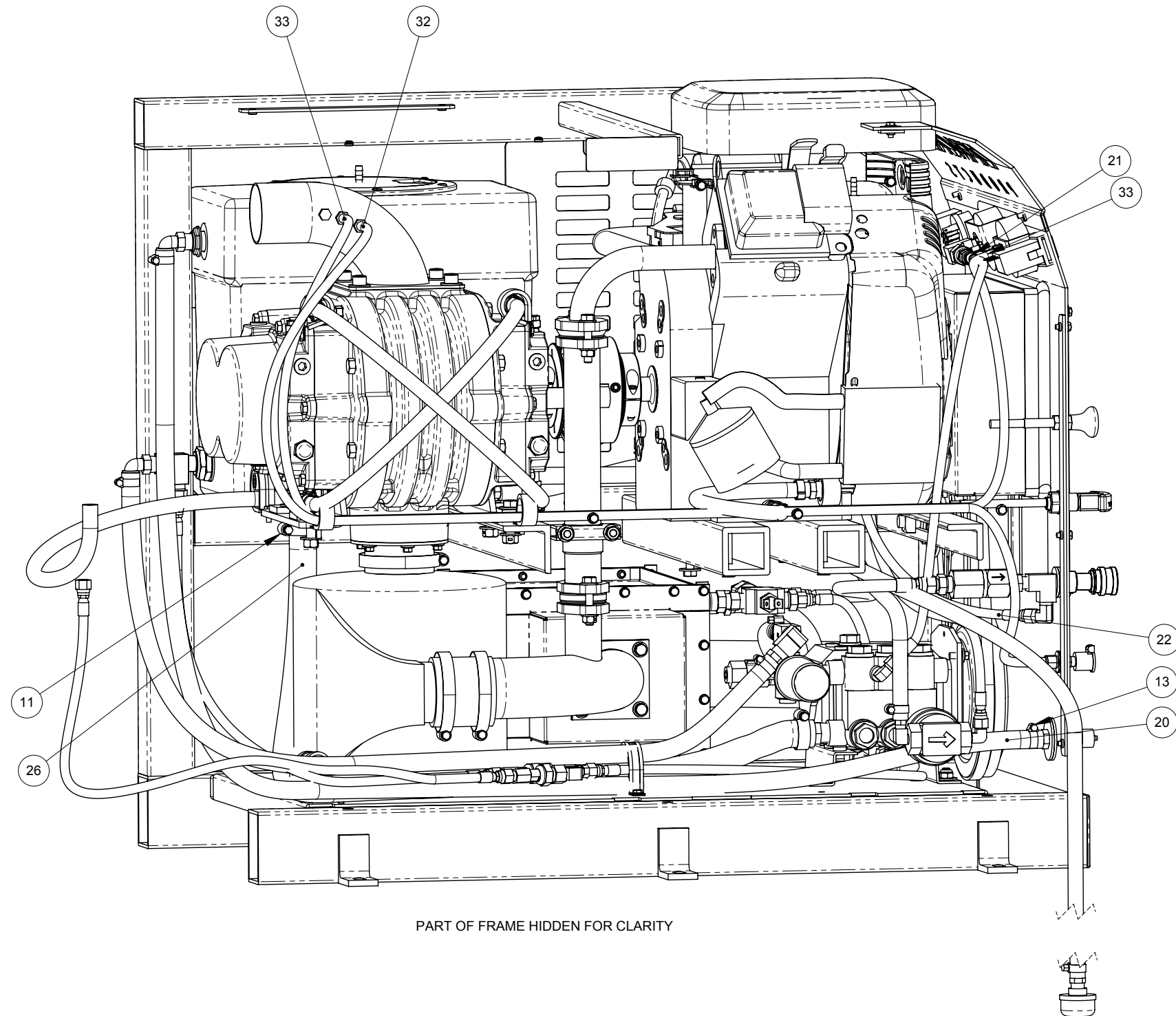
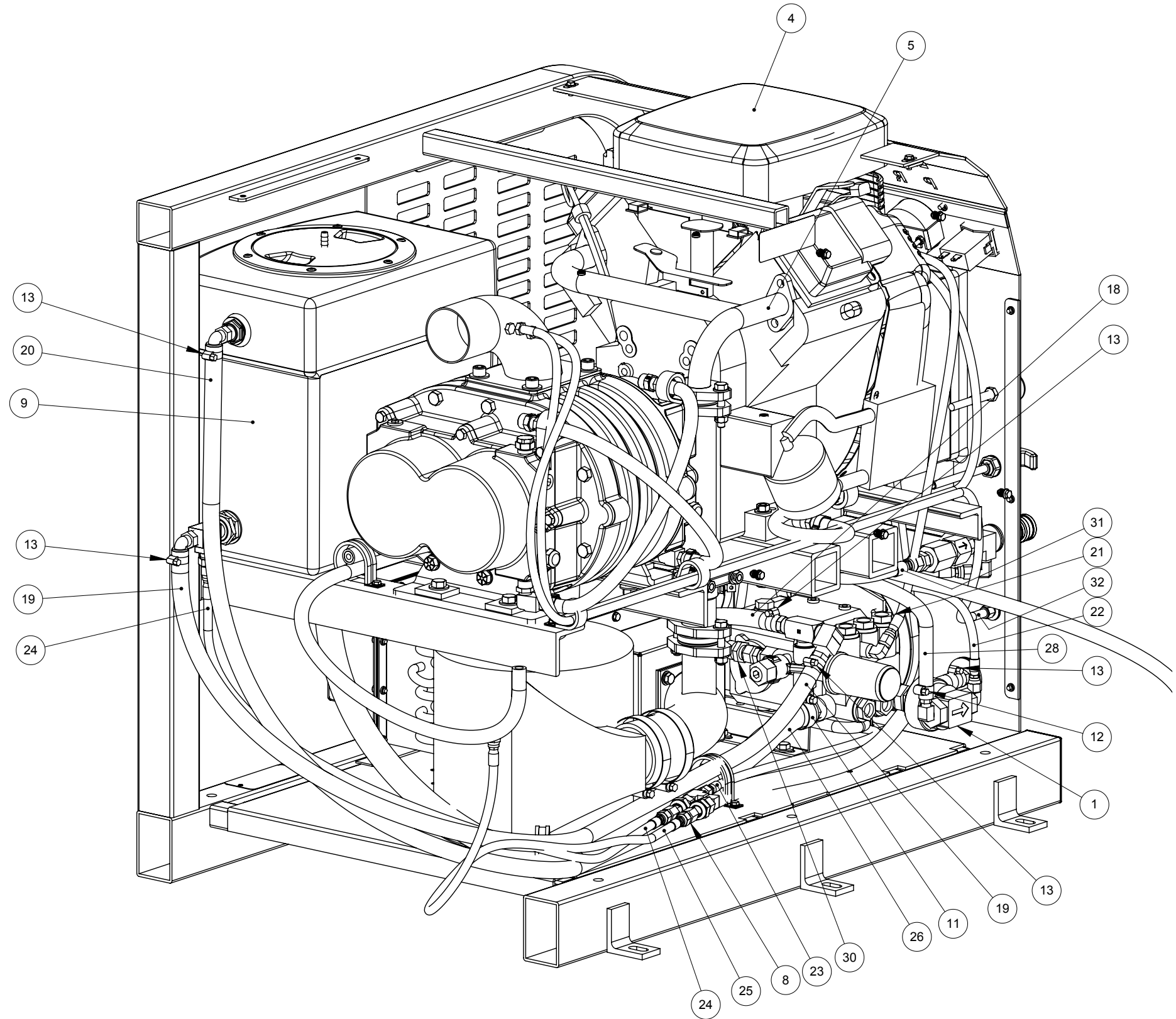

Figure 8-4. Console Assembly - View 3 of 6
610-050-754 Rev. A



GTXR+

Figure 8-5. Console Assembly - View 4 of 6
610-050-754 Rev. A



PART OF FRAME HIDDEN FOR CLARITY

Figure 8-6. Console Assembly - View 5 of 6
610-050-754 Rev. A

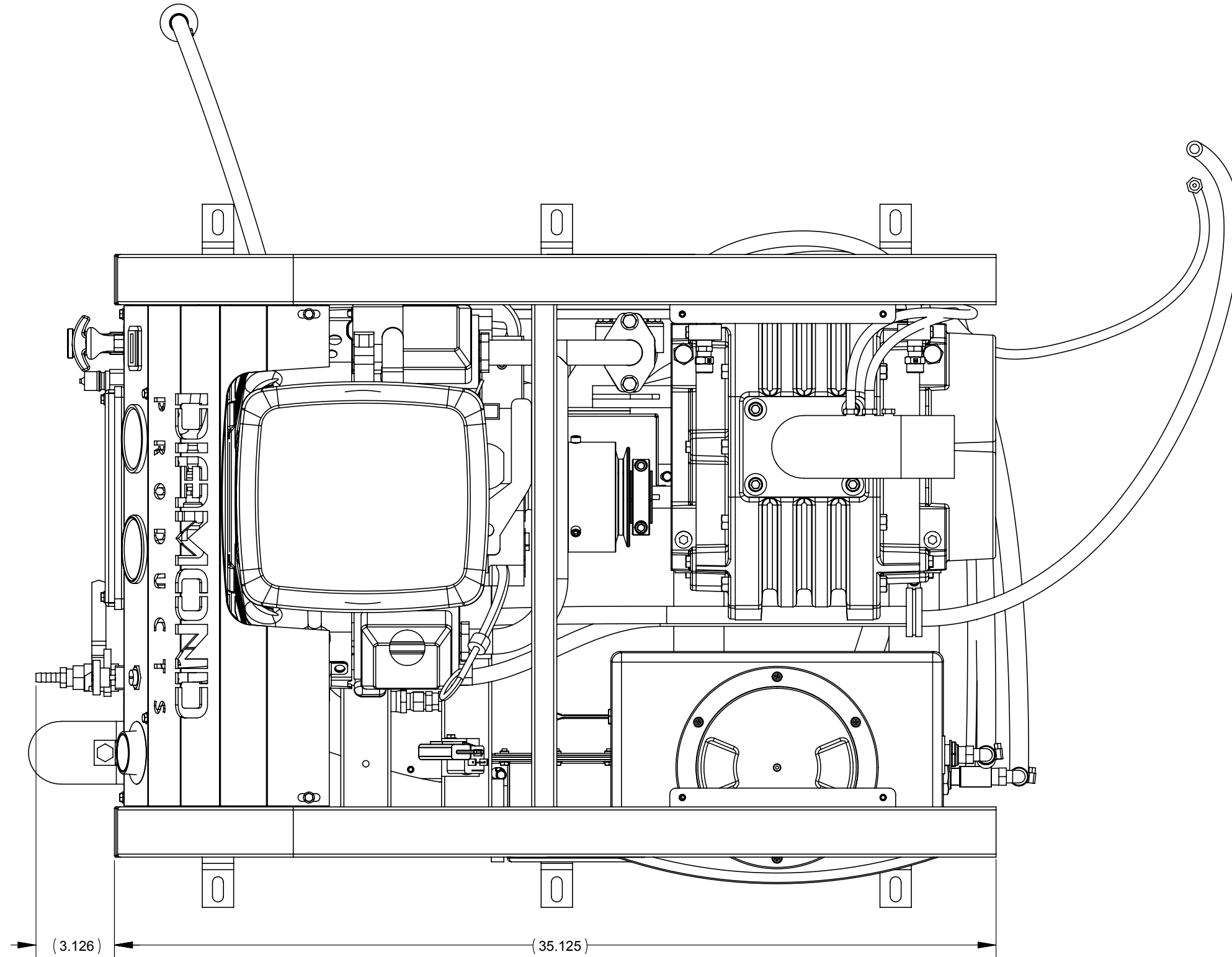

GTXR+

Figure 8-7. Console Assembly - View 6 of 6
610-050-754 Rev. A

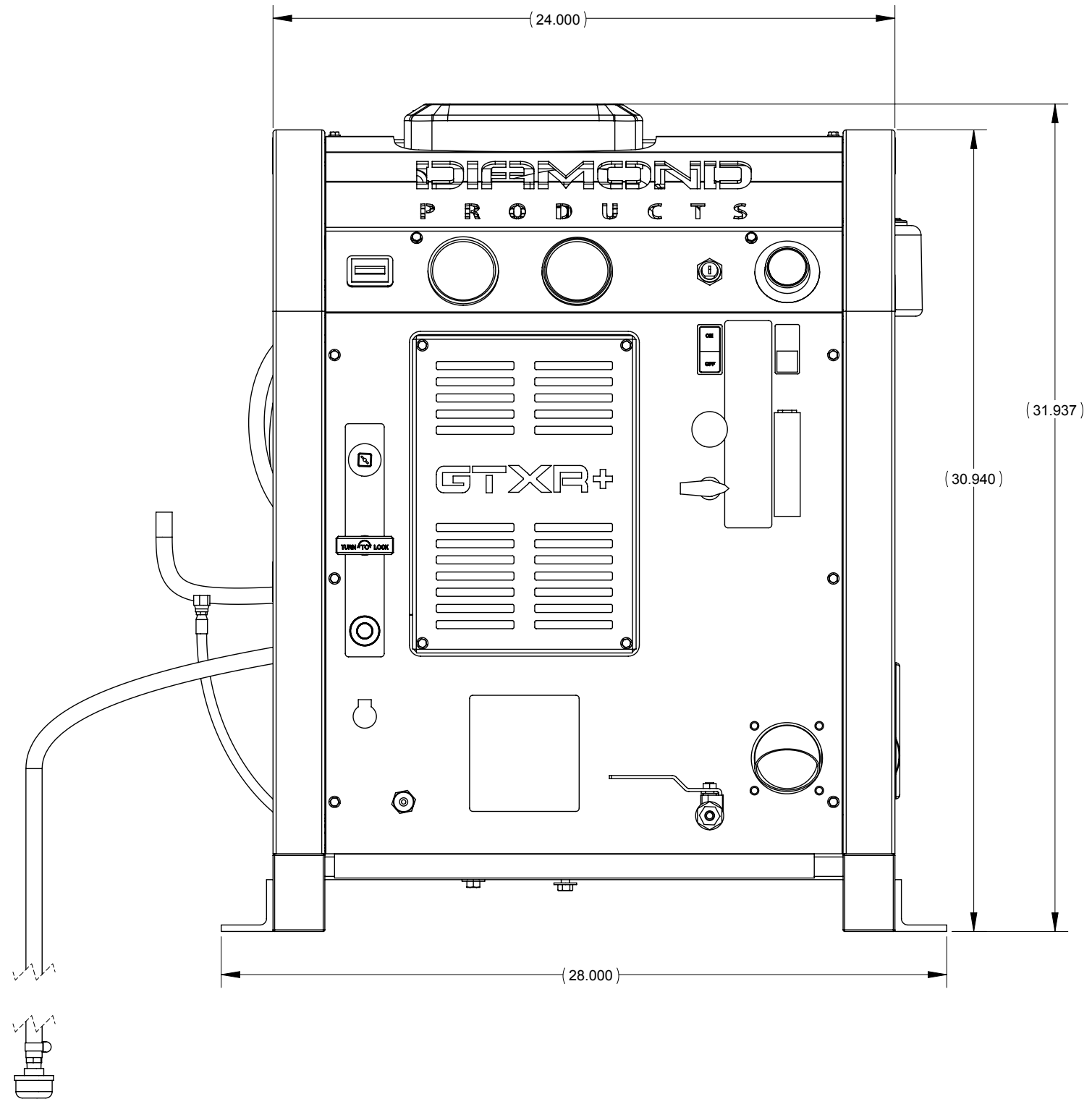

Console Assembly Parts List

Item	Part Number	Description	Qty	Item	Part Number	Description	Qty
1	610-007-737	ASSEMBLY, PUMP	1	24	000-068-203	HOSE, 3/16" I.D. TEFLON x 34" LG. (ORIFICE ASSY TO WB)	1
2	610-002-754	ASSEMBLY, BLOWER	1	25	000-068-627	HOSE, 3/16" I.D. TEFLON x 44" LG. (ORIFICE ASSY TO REC TANK)	1
3	610-018-754	ASSEMBLY, DASH - GTXR PLUS	1	26	000-068-970	HOSE, 3/4" I.D. RUBBER x 50" LG. (PUMP TO WB)	1
4	610-004-728	ASSEMBLY, ENGINE	1	27	000-068-980	HOSE, 3/8" I.D. CLEAR w/ BRAID x 28.5" LG. (CHEM JUG TO FLOW)	1
5	610-013-754	ASSEMBLY, EXHAUST - GTXR PLUS	1	28	000-068-971	HOSE, 3/8" I.D. CLEAR w/ BRAID x 60" LG. (CHEM PUMP TO FLOW)	1
6	610-001-729	ASSEMBLY, FRAME	1	29	000-068-972	HOSE, 3/8" I.D. RUBBER x 76" LG. (CHEM PRIME TO REC TANK)	1
7	610-005-754	ASSEMBLY, HEAT EXCHANGER - GTXR PLUS	1	30	000-068-587	HOSE, 3/8" I.D. THROB x 17.5" LG. (THROB)	1
8	610-021-729	ASSEMBLY, ORIFICE	1	31	000-068-724	HOSE, 5/16" I.D. TEFLON x 18" LG. (HX TO SOL OUT)	1
9	610-010-729	ASSEMBLY, WATER BOX	1	32	000-068-978	HOSE, 5/32" I.D. VACUUM x 52" LG. (BLOWER TO LUBE PORT)	1
10	000-010-124	BELT, 9430HD	1	33	000-068-977	HOSE, 5/32" I.D. VACUUM x 82" LG. (BLOWER TO VAC GAUGE)	1
11	000-033-029	CLAMP, SIZE #12 HOSE	2	34	000-052-102	INSERT, #46 (1/4" NPT x 3/8" BARB)	1
12	000-033-003	CLAMP, SIZE #4 MINI HOSE	5	35	000-105-012	PLATE, MACHINE SERIAL I.D.	1
13	000-033-005	CLAMP, SIZE #5 HOSE	6	36	000-140-001	RIVET, AB4-3A ALUMINUM POP 1/8" x 1/4" LG. (GRIP RANGE 0.126"-0.187")	2
14	000-041-900	COVER, BROW - MACHINE - COATED	1	37	000-143-126	SCREW, #10-24UNC x 0.50" LG. HEX HEAD	11
15	000-041-451	COVER, LEFT SIDE - COATED	1	38	000-174-001	WASHER, #10 FLAT	11
16	000-041-452	COVER, RIGHT SIDE - COATED	1	39	000-174-014	WASHER, #10 LOCK	9
17	000-049-118	FILTER, CHEMICAL INLET HIGH PRESSURE	1				
18	000-068-967	HOSE, 1/2" I.D. RUBBER x 20" LG. (WB DRAIN)	1				
19	000-068-968	HOSE, 1/2" I.D. RUBBER x 56" LG. (PUMP TO WB)	1				
20	000-068-969	HOSE, 1/2" I.D. RUBBER x 69" LG. (FRESH WATER IN TO WB)	1				
21	000-068-518	HOSE, 3/16" I.D. TEFLON x 18.25" LG. (PUMP TO GAUGE)	1				
22	000-068-517	HOSE, 3/16" I.D. TEFLON x 23" LG. (CHEM PUMP TO PRIME & CHEM METERING TO SOL OUT)	2				
23	000-068-888	HOSE, 3/16" I.D. TEFLON x 24" LG. (HX TO ORIFICE ASSY)	1				

GTXR+

Figure 8-8. Frame Assembly - View 1 of 2
610-001-729 Rev. E

NOTICE

P/N 000-081-327 is part of label set
P/N 000-081-039. Only label sets
can be sold; individual labels not
available for sale.

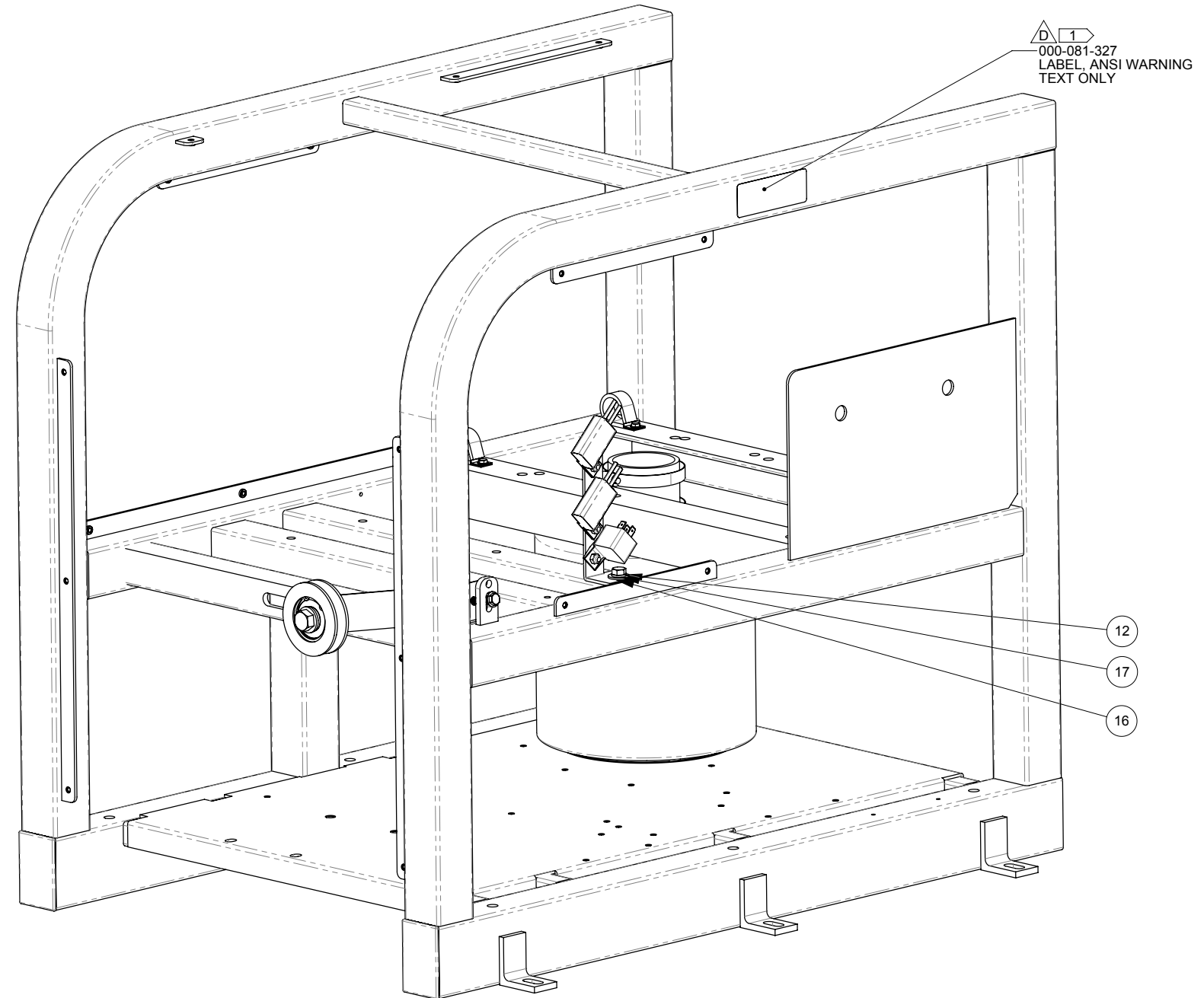

Figure 8-9. Frame Assembly - View 2 of 2
610-001-729 Rev. E

NOTICE

P/N 000-081-327 and 000-081-408 are part of label set P/N 000-081-039. Only label sets can be sold; individual labels not available for sale.

Frame Assembly Parts List

Item	Part Number	Description	Qty
1	610-021-009	ASSEMBLY, IDLER PULLEY	1
2	610-021-724	ASSEMBLY, SILENCER	1
3	000-015-177	BRACKET, DUAL HEAT EXCHANGER MOUNTING - LEFT - COATED	1
4	000-027-110	CAP, 2" X 3" FRAME END	2
5	000-033-050	CLAMP, 1-3/4" CUSHION LOOP	1
6	000-033-057	CLAMP, 1" CUSHION LOOP	2
7	000-033-067	CLAMP, 2" CUSHION LOOP	2
8	000-055-195	FRAME, COMPLETE - COATED	1
9	000-056-006	FUSE HOLDER, IN-LINE - WEATHERPROOF	2
10	000-056-011	FUSE, 30 AMP	2
11	000-094-034	NUT, #10-24UNC NYLOCK	3
12	000-143-012	SCREW, 5/16"-18UNC x 3/4" LG.	1
13	000-143-583	SCREW, #10-24UNC x 0.50" LG. HEX HEAD FLANGE Z/P	8
14	000-157-022	SWITCH, RELAY	1
15	000-131-131	TRIMLOK, 3/8" x 1/8" RUBBER - BULK	1
16	000-174-004	WASHER, 5/16" FLAT, USS	1
17	000-174-018	WASHER, 5/16" LOCK	1

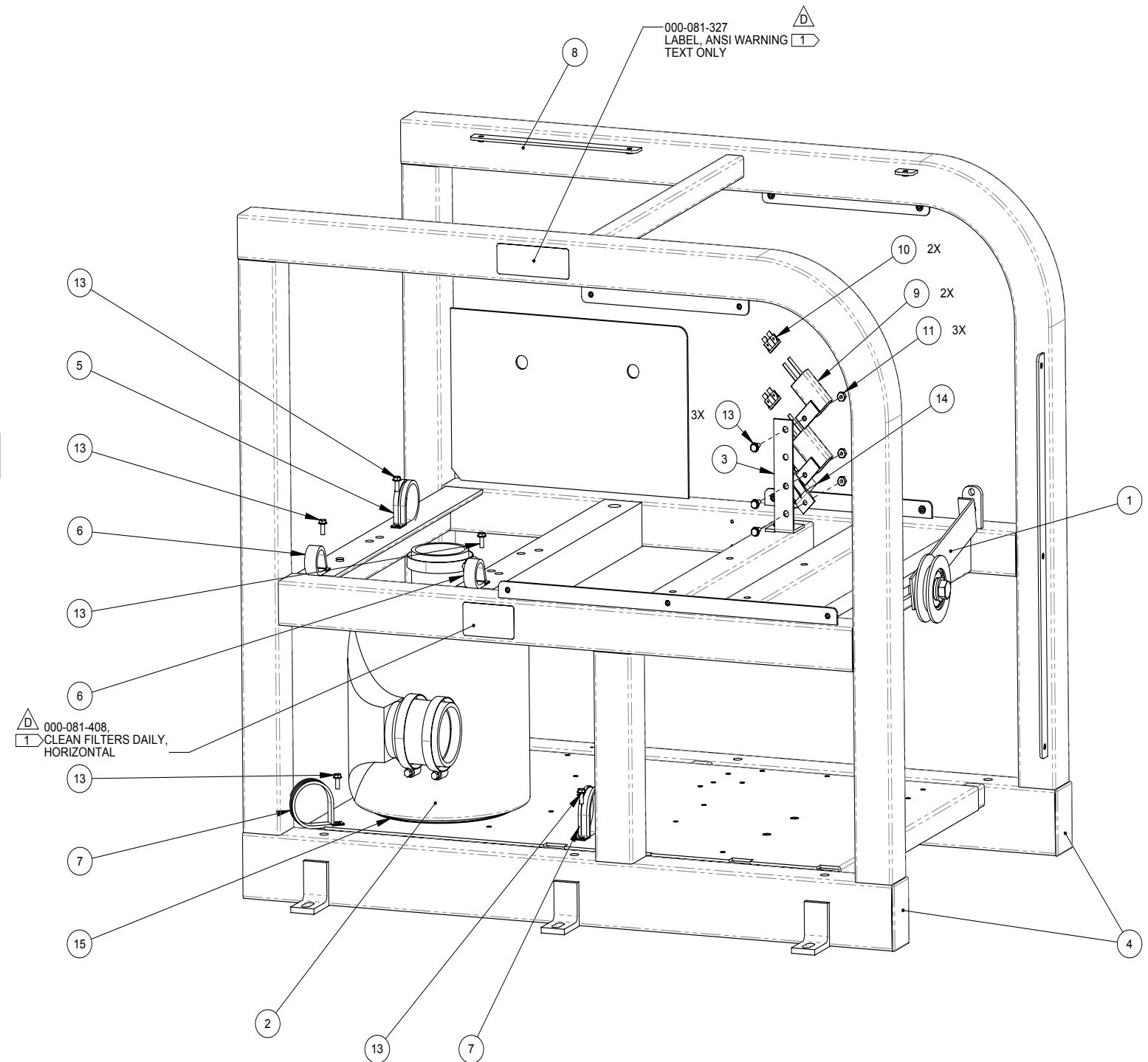

GTXR+

Figure 8-10. Blower Assembly - View 1 of 2
610-002-754 Rev. B

NOTICE

See Figure 9-1 for adhesive/sealant information.

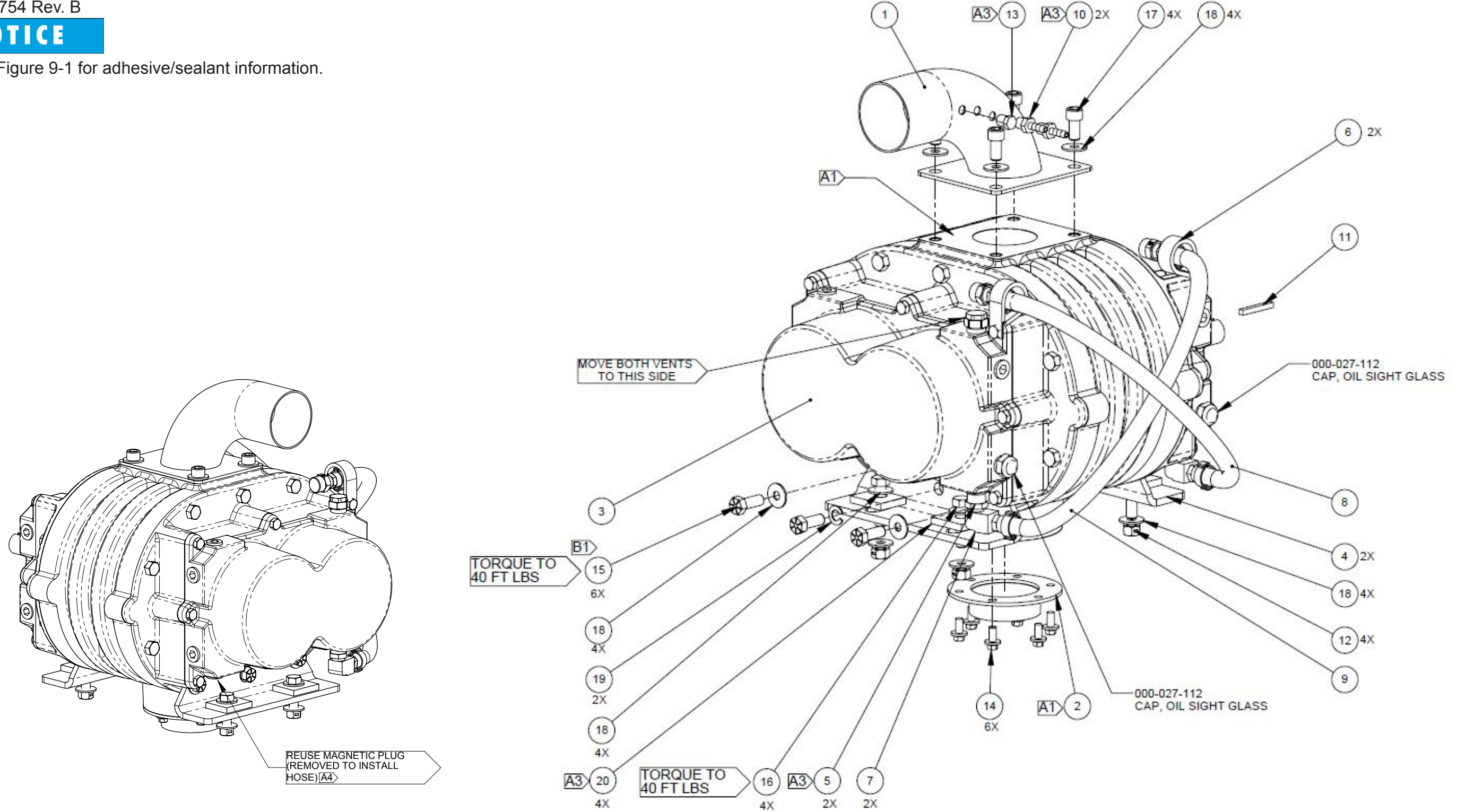
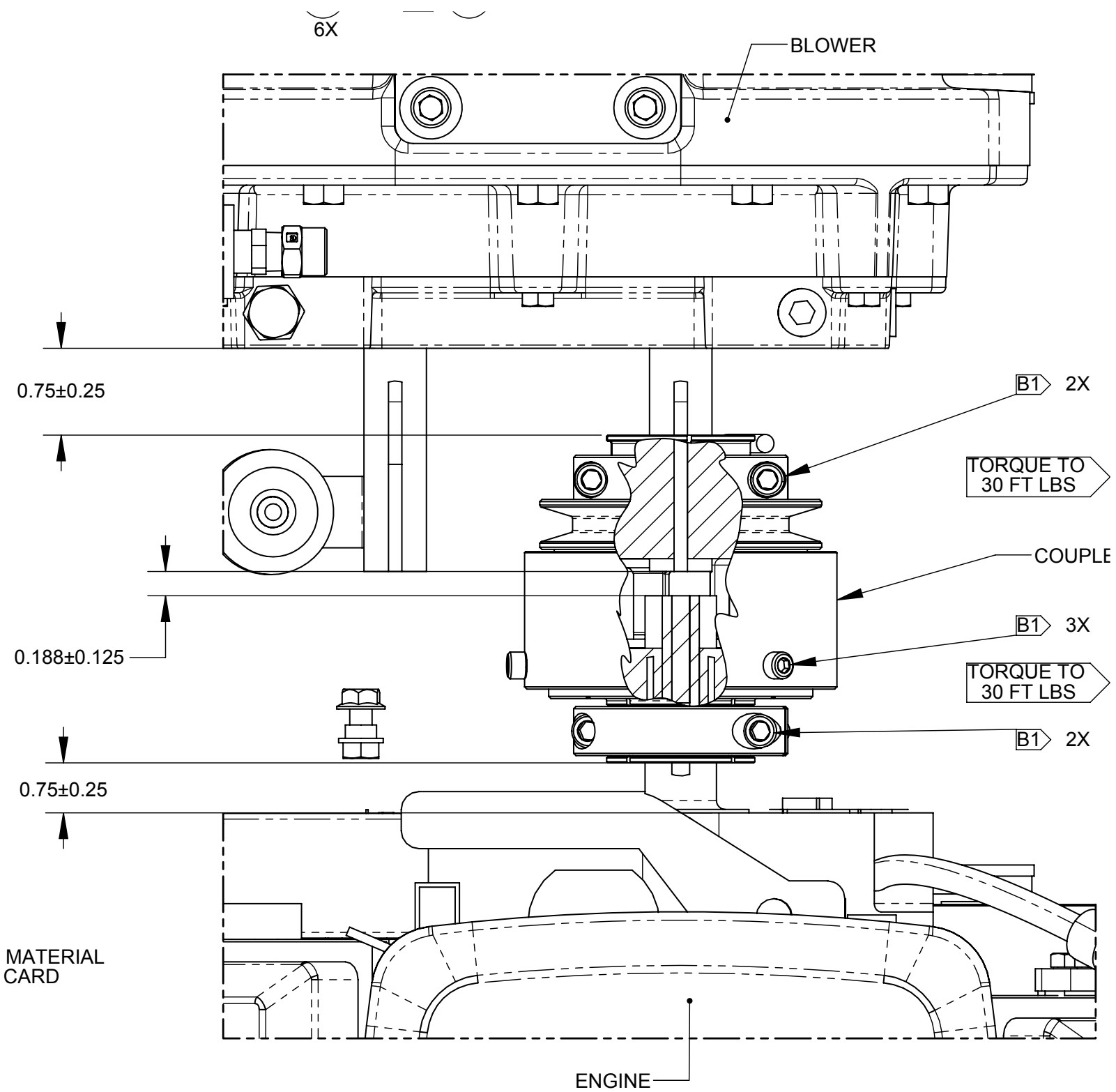

Figure 8-11. Blower Assembly - View 2 of 2
610-002-754 Rev. A

NOTICE

See Figure 9-1 for sealant information.



NOTES:
1. SEE ENG-45975 OR ADHESIVE MATERIAL
PRODUCTION LINE REFERENCE CARD
FOR SEALANT INFORMATION.

Blower Assembly Parts List

Item	Part Number	Description	Qty
1	000-001-071	ADAPTER BLOWER INLET - COATED	1
2	000-001-871	ADAPTER BLOWER OUTLET 2.5 - COATED	1
3	000-111-145	BLOWER, 4005 DOMINATOR	1
4	000-015-032	BRACKET, DOMINATOR 4005 MOUNTING - COATED	2
5	000-052-061	BUSHING, 3/8" NPT x 1/4" FPT	2
6	000-033-057	CLAMP, 1" CUSHION LOOP	2
7	000-052-085	ELBOW, 1/4" NPT STREET	2
8	000-068-794	HOSE ASSEMBLY, 3/8" x 17" LG. DRAIN	1
9	000-068-794	HOSE ASSEMBLY, 3/8" x 17" LG. DRAIN	1
10	000-052-293	INSERT, #23 (1/8" NPT x 3/16" BARB)	2

Item	Part Number	Description	Qty
11	000-077-011	KEY, 3/16" X 1 1/2" LONG	1
12	000-094-015	NUT, 3/8"-16UNC HEX 2 WAY LOCKING	4
13	000-106-001	PLUG, 1/8" NPT	1
14	000-143-141	SCREW, 1/4"-20UNC x 0.50" LG. WHIZ LOCK	6
15	000-143-018	SCREW, 3/8"-16UNC X 1.00" LG. HEX HD - GRADE 8	6
16	000-143-200	SCREW, 3/8"-16UNC x 1.50" LG. HEX HD GRADE 8	4
17	000-143-094-1	SCREW, 3/8"-16UNC x 0.75" LG. SOCKET HD	4
18	000-174-004	WASHER, 5/16" FLAT, USS	16
19	000-174-057	WASHER, 3/8" LOCK	2
20	000-174-068	WASHER, BLOWER FEET - COATED	4

Figure 8-12. Silencer Assembly
610-021-724 Rev. B

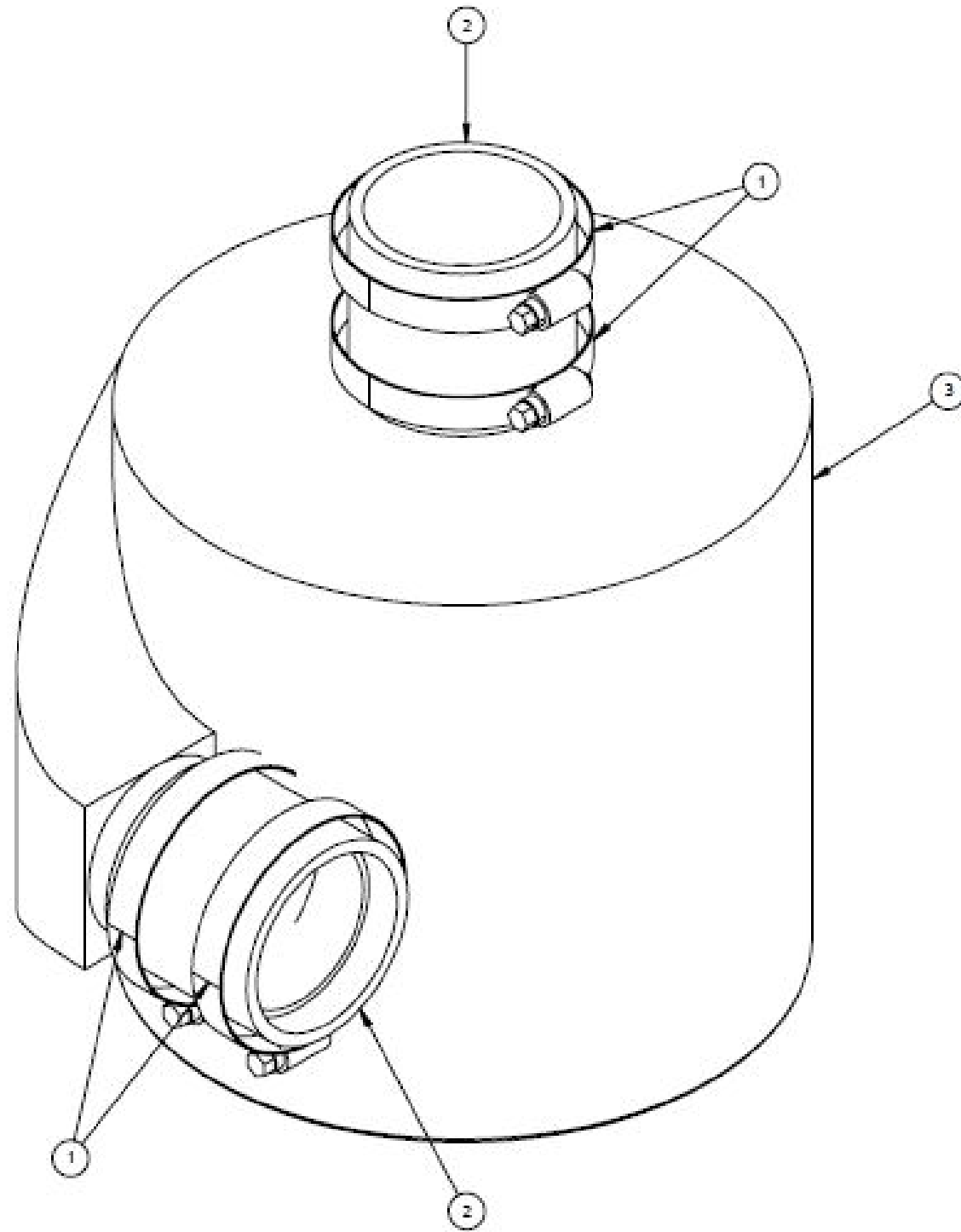

Silencer Assembly Parts List **GTXR+**

Item	Part Number	Description	Qty
1	000-033-012	CLAMP, SIZE #44 HOSE	4
2	000-068-104	HOSE, Ø2.5" ID x 2.5" LG.	2
3	000-093-108	SILENCER, Ø2.5" OD INLET/OUTLET - COATED	1

GTXR+

Figure 8-13. Engine Assembly - View 1 of 2
610-004-728 Rev. E

NOTICE

See Figure 9-1 for adhesive/sealant information.

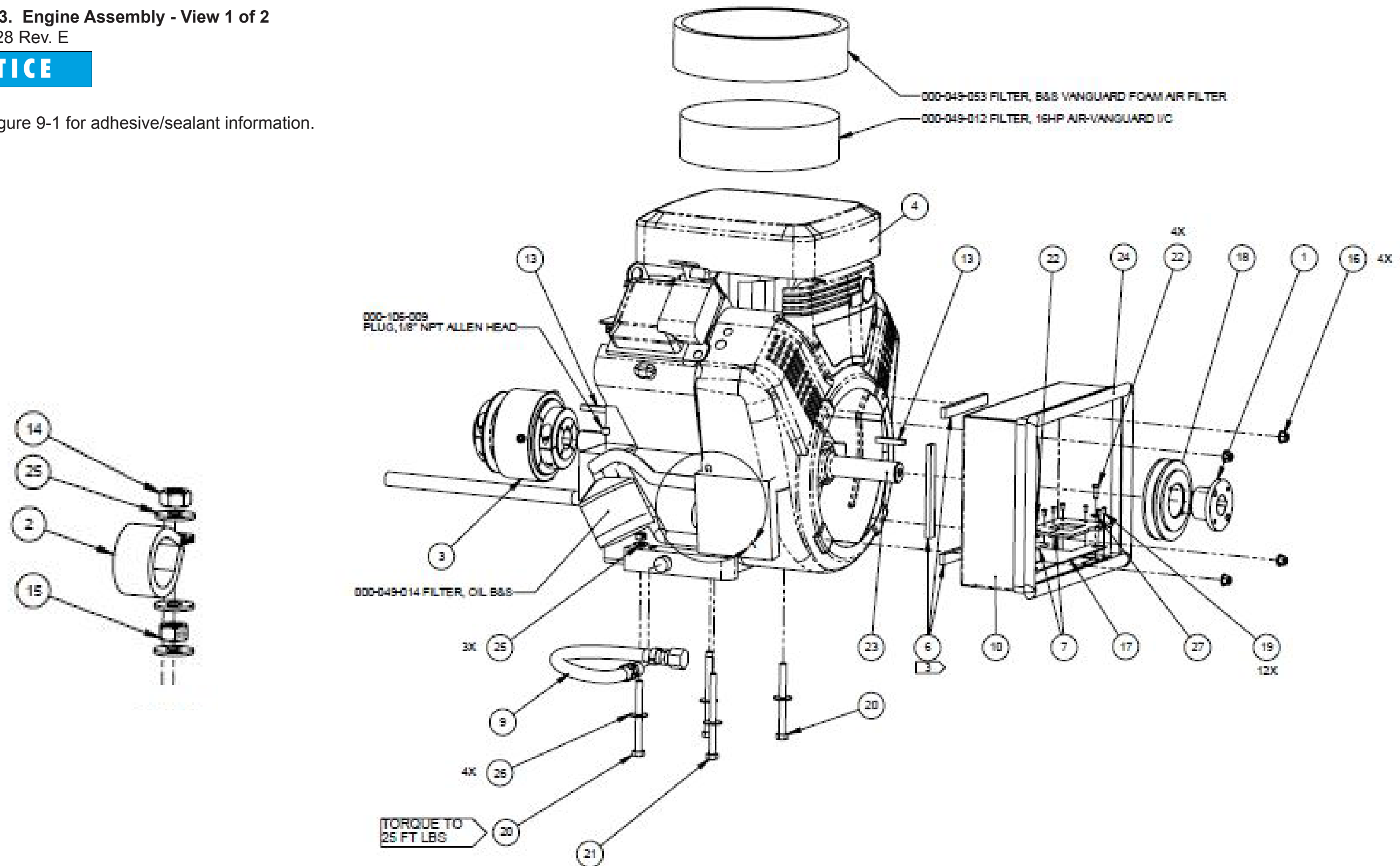
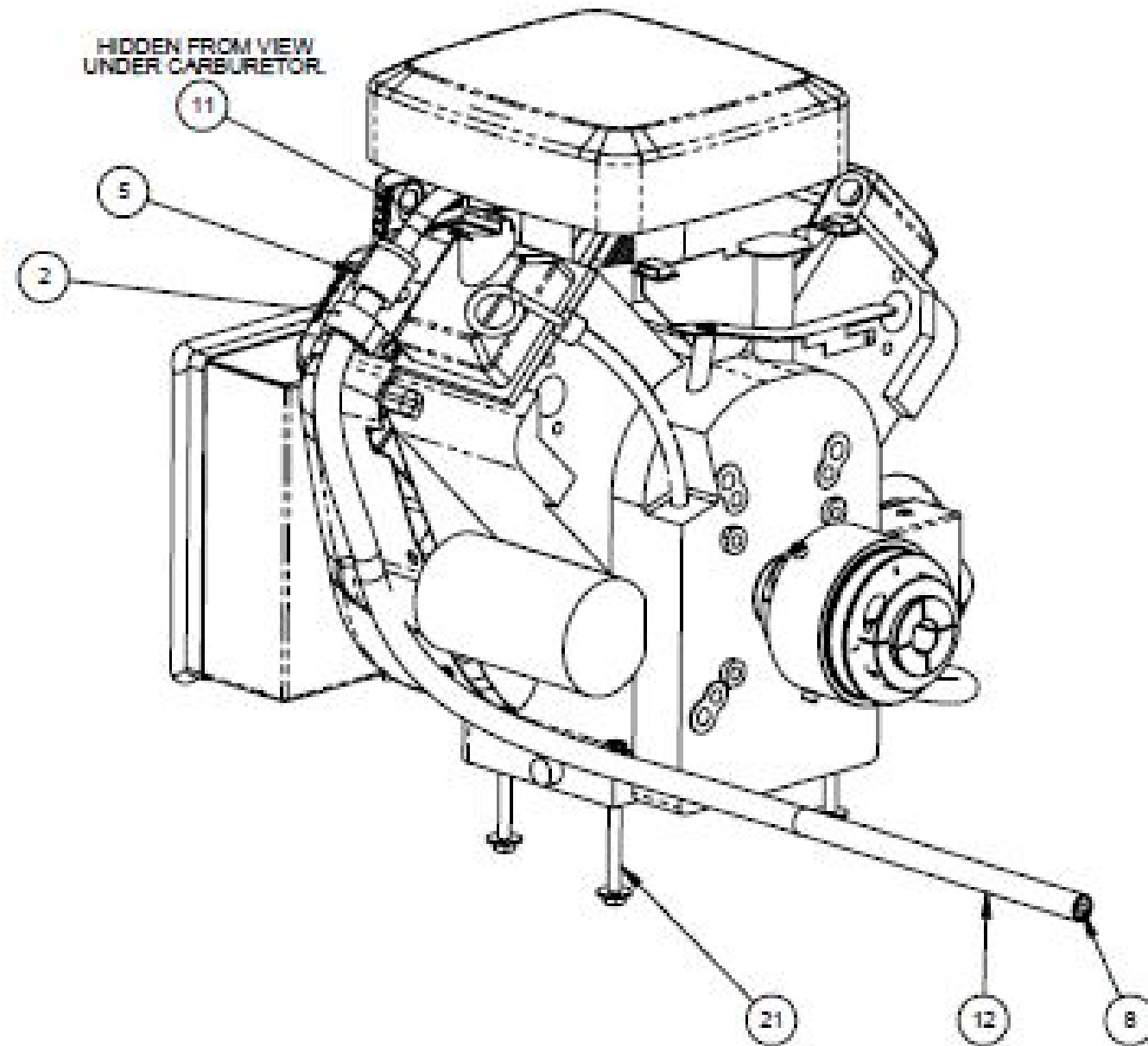

Figure 8-14. Engine Assembly - View 2 of 2
610-004-728 Rev. E



Engine Assembly Parts List

Item	Part Number	Description	Qty
1	000-020-025	Bushing, H X 1"	1
2	000-033-117	Clamp, 1" Cushion Loop w/ 7/16 Mount Hole	2
3	000-039-054	Coupler, 40 Series	1
4	000-047-037	Engine, 23HP	1
5	000-049-258	Filter, Fuel (Comes w/ Engine)	1
6	000-057-026	Gasket, 1/2" X 1/4" X 18-1/8" Lg.	2
7	000-057-226	Gasket, Engine Duct	2
8	000-068-979	Hose, 1/4" I.D. Fuel Low Perm X 120" Lg.	1
9	000-068-219	Hose, Drain	1
10	000-042-074	Housing, Radiator Duct - Coated	1
11	000-052-293	Insert, #23 (1/8" NPT X 3/16" Barb)	1
12	000-131-139	Insulation, 1" Hi-Temp Alum Sleeve X 60" Lg.	1
13	000-077-010	Key, 1/4" X 1-1/2" Lg. Class 2 Fit	2
14	000-094-012	Nut, 5/16"-18UNC Hex	1
15	000-094-081	Nut, 5/16"-18UNC Hex 2 Way Locking	4
16	000-094-125	Nut, 6mm Hex Nylock Flange S/S	4
17	000-105-562	Plate, Engine Duct - Coated	1
18	000-109-040	Pulley, AK47-H	1
19	000-140-001	Rivet, AB4-3A Aluminum Pop 1/8" X 1/4" Lg.	12
20	000-143-659	Screw, 5/16"-18UNC X 3.5" Lg. Grade 8	2
21	000-143-660	Screw, 5/16"-18UNC X 4.0" Lg., Hex Head	2
22	000-143-126	Screw, #10-24UNC X 0.50" Lg. Hex Head	4
23	000-150-169	Shaft, 23HP Stub	1
24	000-131-060	Trimlok, 3/4" Bulb X 3/16" Opening (40" Lg.)	1
25	000-174-002	Washer, 1/4" Flat	6
26	000-174-004	Washer, 5/16" Flat, Uss	4
27	000-174-001	Washer, #10 Flat	4

GTXR+

Figure 8-15. Pump Assembly
610-007-737 Rev. B

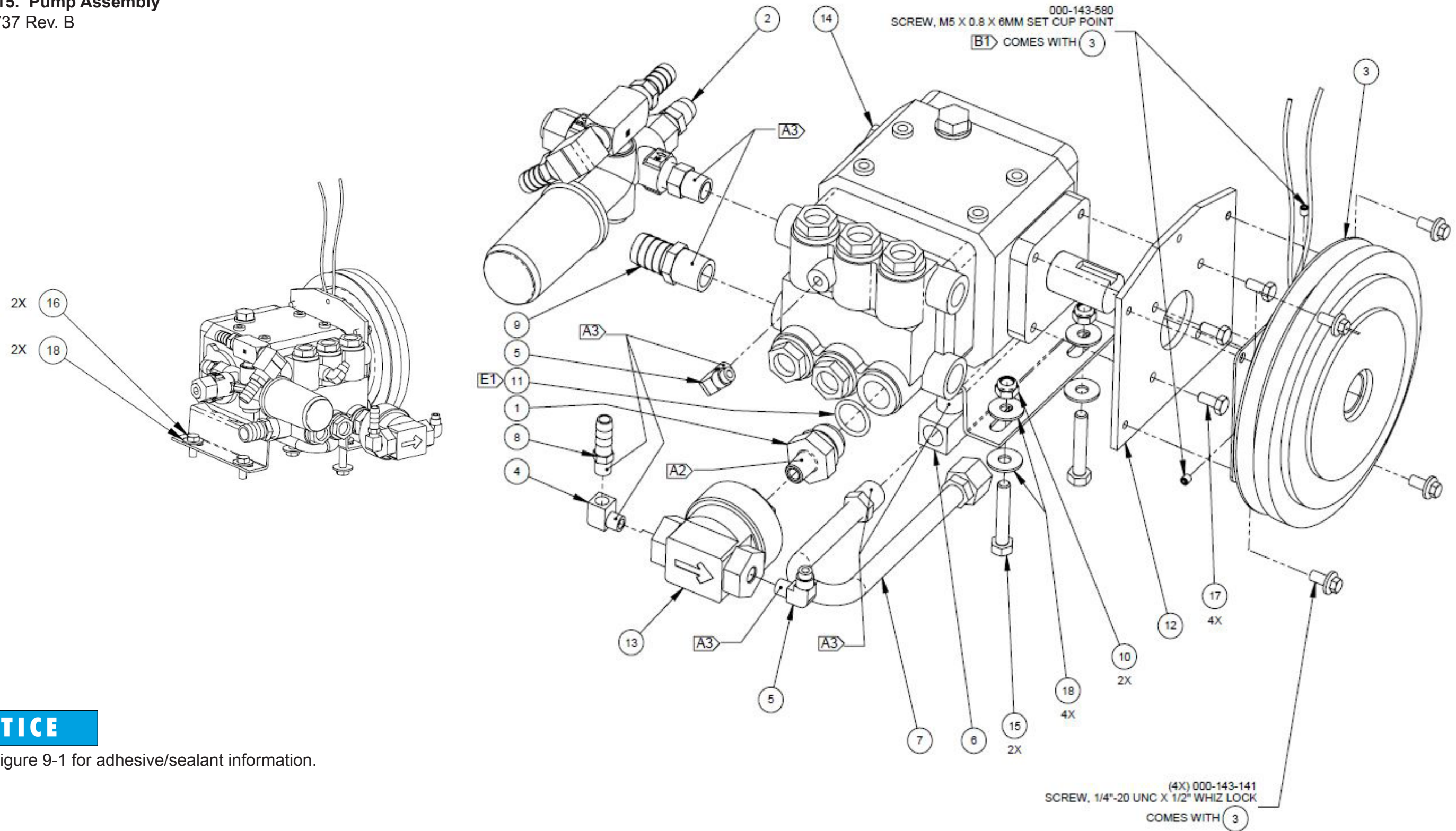

NOTICE

See Figure 9-1 for adhesive/sealant information.

Pump Assembly Parts List

Item	Part Number	Description	Qty
1	000-001-096	ADAPTER, CHEM. PUMP TO COMET	1
2	610-009-747	ASSEMBLY, BY-PASS VALVE - CTS 400 FLEX	1
3	000-036-008	CLUTCH, 7" O.D. 24mm SINGLE GROOVE	1
4	000-052-084	ELBOW, 1/8" NPT STREET	1
5	000-052-531	ELBOW, 1/8" NPT x 1/4" SAE	2
6	000-052-086	ELBOW, 3/8" NPT STREET	1
7	000-068-219	HOSE, DRAIN	1
8	000-052-099	INSERT, #26 (1/8" NPT x 3/8" BARB)	1
9	000-052-129	INSERT, #812, 1/2NPT X 3/4 HOSE	1

Item	Part Number	Description	Qty
10	000-094-038	NUT, 5/16"-18UNC HEX NYLOCK	2
11	000-097-057	O-RING, ADAPTER - CHEMICAL PUMP	1
12	000-105-148	PLATE, CLUTCH MOUNT COMET PUMP	1
13	000-111-184	PUMP, GP CHEMICAL	1
14	000-111-042	PUMP, HYDRAPUMP II	1
15	000-143-375	SCREW, 5/16"-18UNC x 1.75" LG. HEX HD GRD. 8 Z/P	2
16	000-143-012	SCREW, 5/16"-18UNC x 3/4" LG.	2
17	000-143-221	SCREW, M6-1 X 14MM LG. HEX HEAD	4
18	000-174-004	WASHER, 5/16" FLAT, USS	6

GTXR+

Figure 8-16. Blower Heat Exchanger Assembly - View 1 of 2
610-005-754 Rev. A

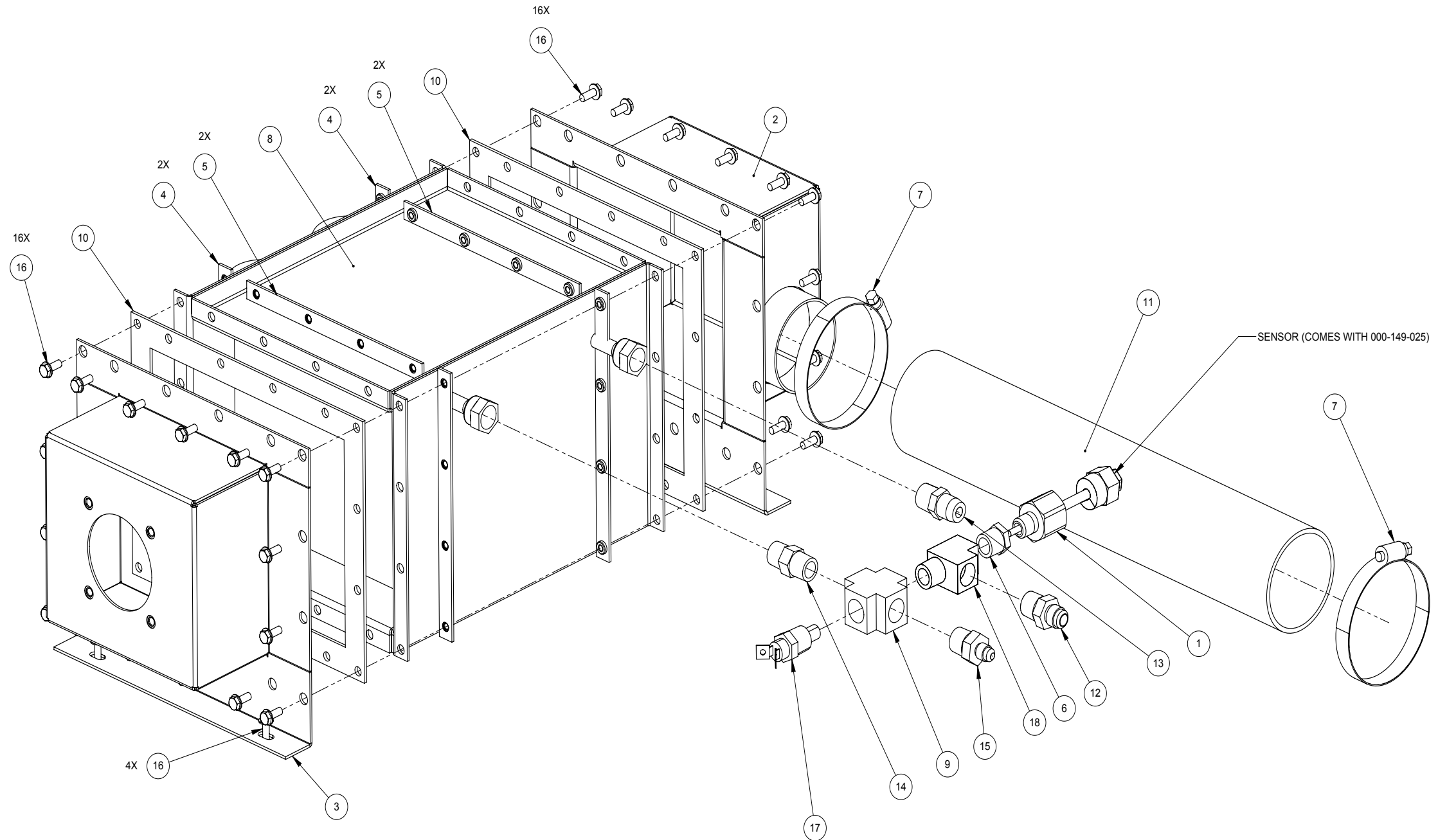

NOTICE

See Figure 9-1 for sealant information.

Blower Heat Exchanger Assembly Parts List

Item	Part Number	Description	Qty	Item	Part Number	Description	Qty
1	000-052-738	ADAPTER, 1/4" NPT x 1/2" FPT	1	10	000-057-255	GASKET, SALSA HX - CDS ZR-2017	2
2	000-013-115	BOX, OUTLET PLENUM, STEEL - COATED	1	11	000-052-528	NIPPLE, 3/8" M JIC x 3/8" NPT	1
3	000-013-118	BOX, PLENUM INLET, STEEL - COATED	1	12	000-052-128	NIPPLE, 3/8" MPT x 3/8" SAE FLARE	1
4	000-015-1303	BRACKET, HX PLENUM SIDE BACKING	4	13	000-052-074	NIPPLE, 3/8" NPT HEX	1
5	000-015-1302	BRACKET, HX PLENUM TOP BACKING	4	14	000-052-662	NIPPLE, 3/8" NPT x 1/4" M SAE	1
6	000-052-061	BUSHING, 3/8" NPT x 1/4" FPT	1	15	000-143-583	SCREW, #10-24UNC x 0.50" LG. HEX HD FLANGE	36
7	000-033-012	CLAMP, SIZE #44 HOSE	2	16	000-149-027	SENSOR, 285F NASON- 3/8" NPT	1
8	000-038-001	CORE, BLOWER HEAT EXCHANGER	1	17	000-052-023	TEE, 3/8" NPT MALE STREET	1
9	000-052-113	CROSS, 3/8" FPT	1	18	000-068-986	HOSE, 2.5" HEAT FLEX NS x 15" LG.	1

Figure 8-17. Blower Heat Exchanger Assembly- View 2 of 2
610-005-754 Rev. A

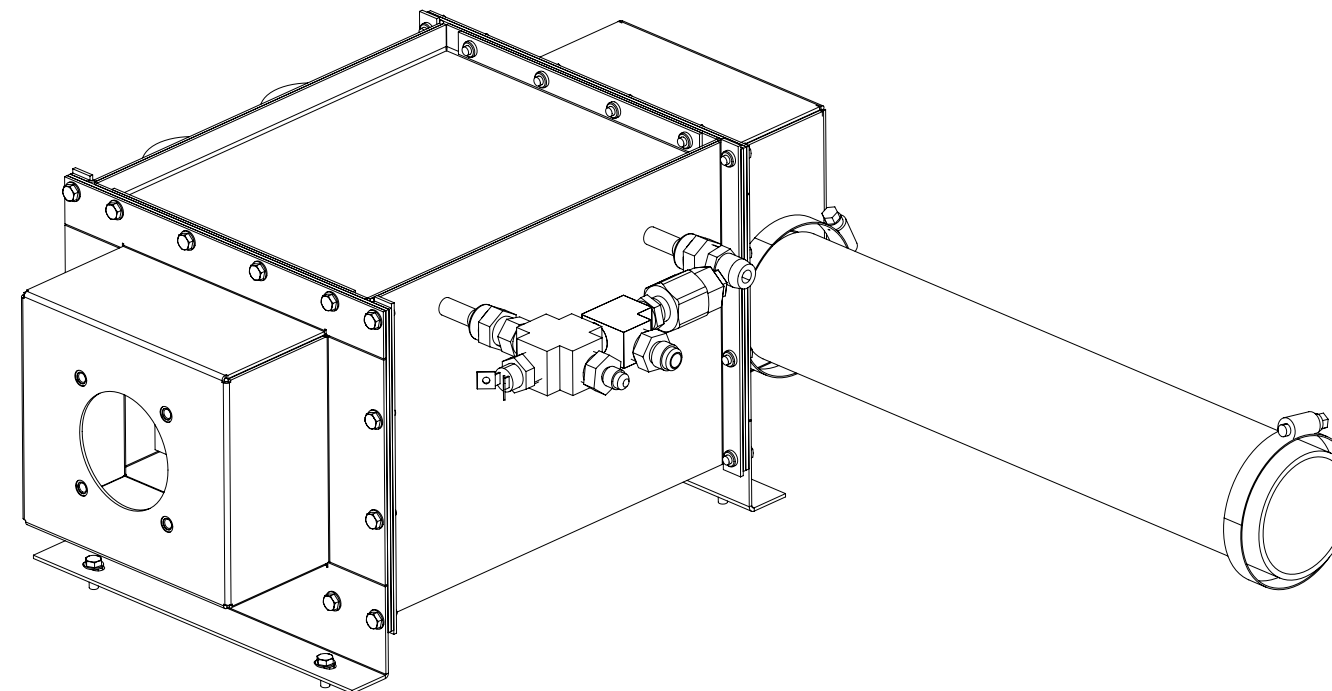

NOTICE

See Figure 9-1 for adhesive and sealant information.

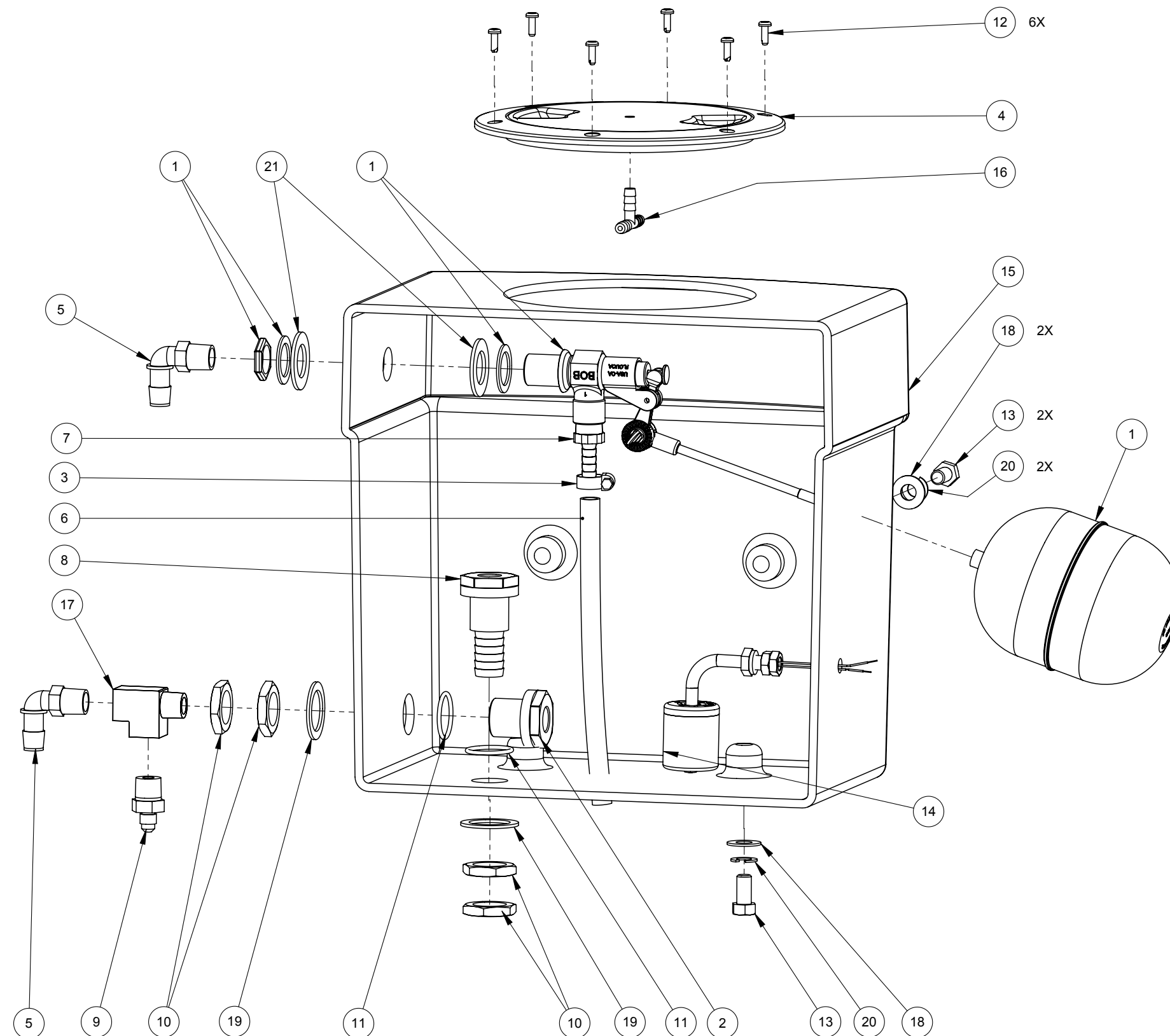

Water Box Assembly Parts List

Item	Part Number	Description	Qty
1	000-169-235	ASSEMBLY, ROBERT FLOAT VALVE	1
2	000-052-660	BULKHEAD, 3/8" FPT x 3/8" FPT	1
3	000-033-003	CLAMP, SIZE #4 MINI HOSE	1
4	000-041-005	COVER, 6" ACCESS	1
5	000-052-355	ELBOW, 3/8" NPT x 1/2" HOSE	2
6	000-068-827	HOSE, 3/8" CLEAR w/ BRAID x 8" LG.	1
7	000-052-104	INSERT, #66 (3/8" NPT x 3/8" BARB)	1
8	000-052-661	INSERT, 3/4" BARB X STRAIGHT	1
9	000-052-662	NIPPLE, 3/8" NPT x 1/4" M SAE	1
10	000-094-097	NUT, 1"-14UNS BRASS	4
11	000-097-041	O-RING, 1/2" BULK HEAD	2

Item	Part Number	Description	Qty
12	000-143-314	SCREW, #8 x 1/2" LG. PAN HEAD	6
13	000-143-017-1	SCREW, 3/8"-16UNC x 0.75" LG. HEX HEAD	3
14	000-157-0801	SWITCH, w/PROTECTOR, BARREL -NC	1
15	000-159-190	TANK, POLY WATER BOX - 4 GALLON - MODIFIED	1
16	000-052-156	TEE, 1/4" PLASTIC	1
17	000-052-023	TEE, 3/8" NPT MALE STREET	1
18	000-174-032	WASHER, 3/8" FLAT	3
19	000-174-063	WASHER, 1.5" O.D. x 1.073" I.D. x 0.075" THK.	2
20	000-174-057	WASHER, 3/8" LOCK	3
21	000-174-028	WASHER, 7/8" I.D. x 1.50" O.D. x 0.090" THK.	2

Figure 8-19. Water Box Assembly - View 2 of 2
610-010-729 Rev. C

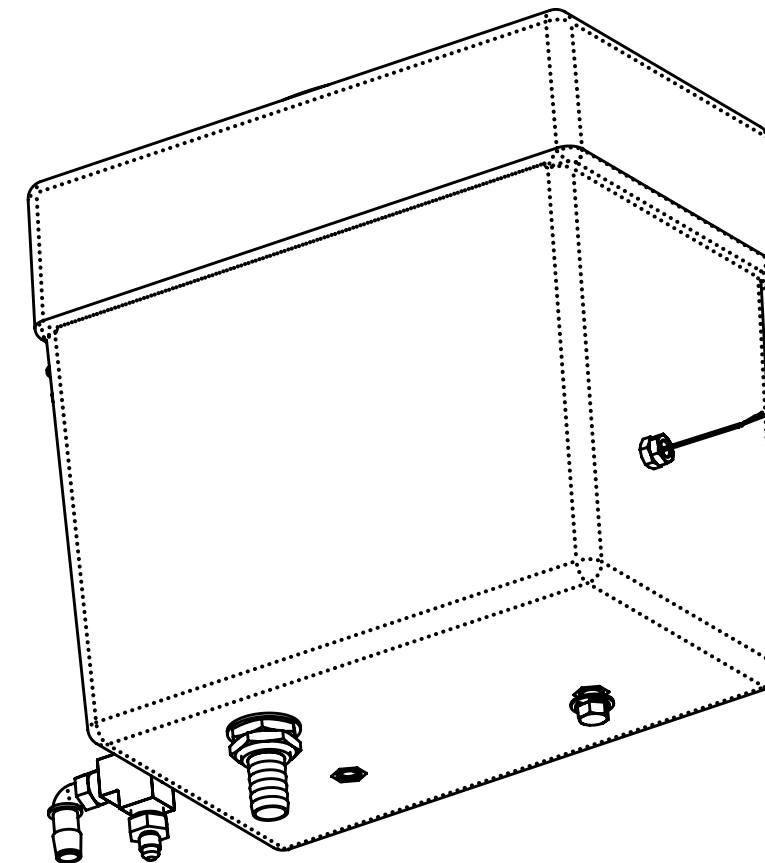
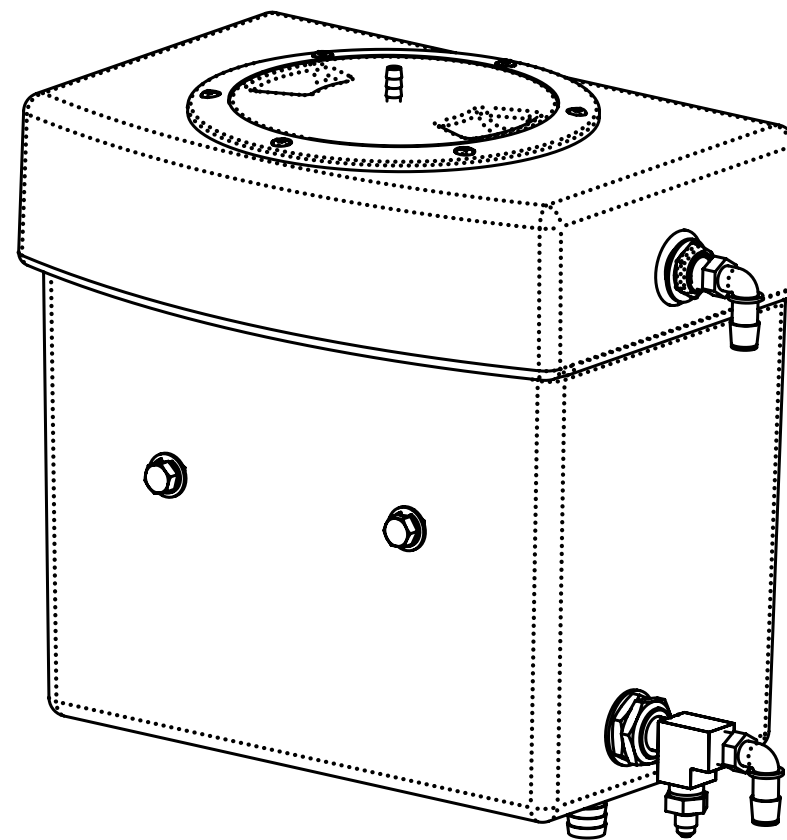

GTXR+

Figure 8-20. Dash Assembly - View 1 of 2
610-018-754 Rev. A

NOTICE

See Figure 9-1 for adhesive/sealant information.

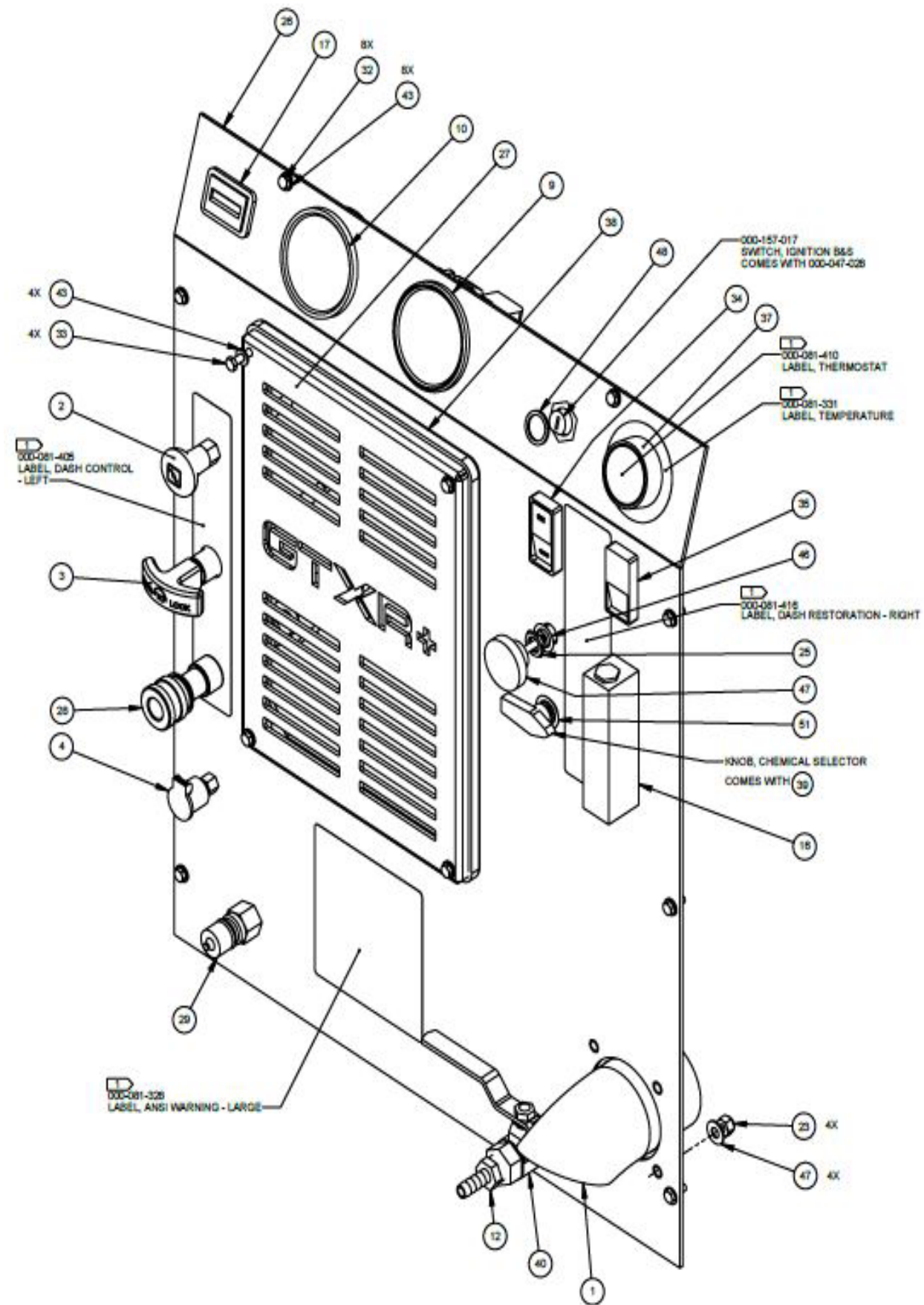
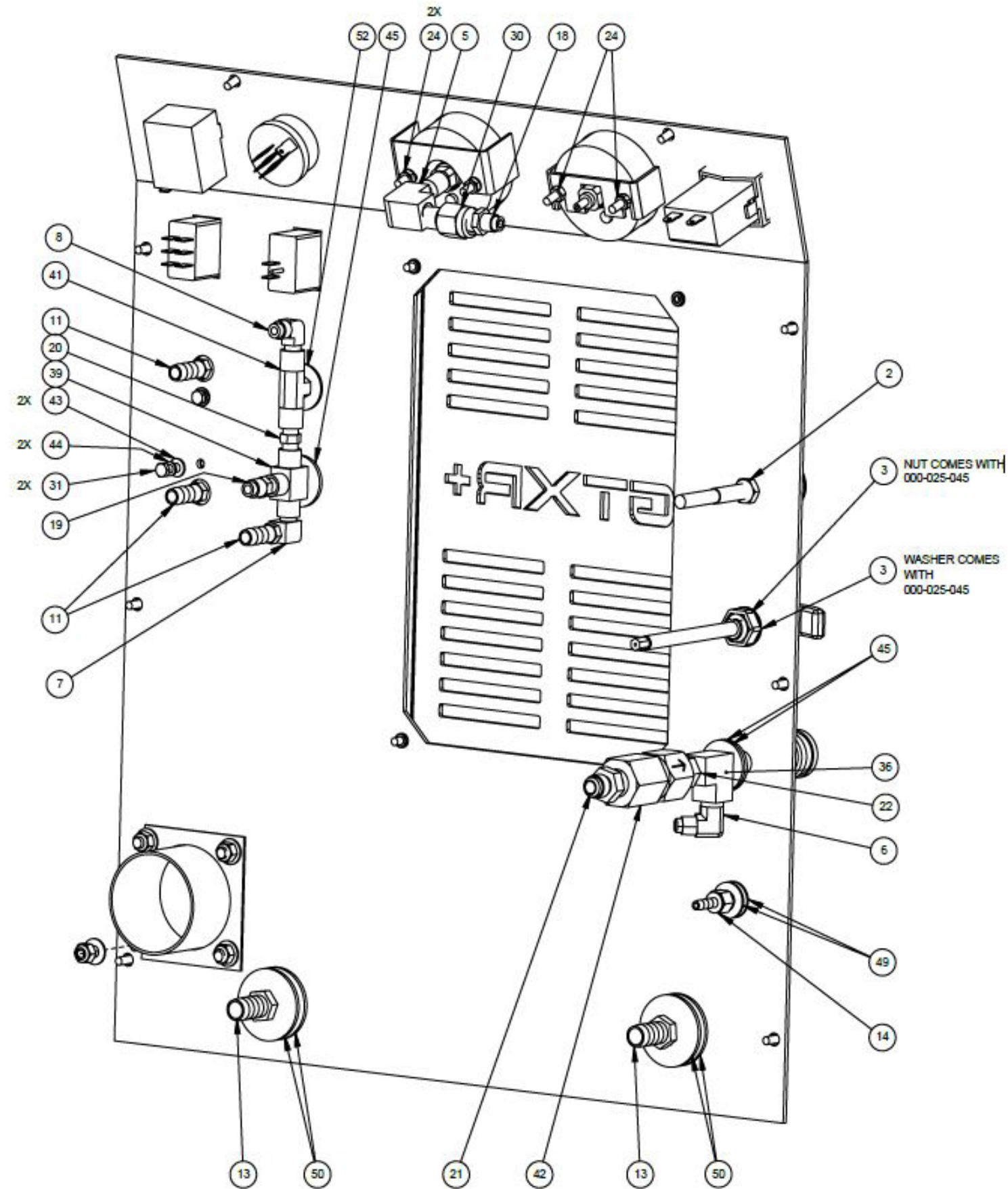

Figure 8-21. Dash Assembly - View 2 of 2
610-018-754 Rev. A



Dash Assembly Parts List

Item	Part Number	Description	Qty	Item	Part Number	Description	Qty
1	000-001-148	ADAPTER, 2.5" EXHAUST TURNDOWN - COATED	1	27	000-100-372	PANEL, GRILL - COATED	1
2	000-025-003	CABLE, CHOKE WITH DETENT	1	28	000-052-051	QUICK CONNECT, 440 FEMALE w/ EPDM O-RING	1
3	000-025-045	CABLE, THROTTLE - TURN TO LOCK	1	29	000-052-052	QUICK CONNECT, 660 3/8" BRASS W/ EPDM O-RING	1
4	000-052-272	CUP, GRAVITY FEED OIL BLOWER LUBE PORT	1	30	000-135-052	REGULATOR, HI PSI SNUBBER	1
5	000-052-088	ELBOW, 1/4" FPT x FPT	1	31	000-143-166	SCREW, #10-24UNC x 0.375" LG. HEX HEAD	2
6	000-052-532	ELBOW, 1/4" SAE x 1/4" NPT	1	32	000-143-126	SCREW, #10-24UNC x 0.50" LG. HEX HEAD	8
7	000-052-084	ELBOW, 1/8" NPT STREET	1	33	000-143-171	SCREW, #10-24UNC x 1.25" LG. HEX HEAD	4
8	000-052-531	ELBOW, 1/8" NPT x 1/4" SAE	1	34	000-157-040	SWITCH, 20 AMP ROCKER	1
9	000-074-007	GAUGE, PRESSURE 0 -1500 PSI, UPC #401406.	1	35	000-157-131	SWITCH, 3 WAY SPEED CONTROL	1
10	000-074-017	GAUGE, 30" HG. VACUUM - HYDRAMASTER	1	36	000-052-090	TEE, 1/4" NPT BRANCH M-F-F	1
11	000-052-099	INSERT, #26 (1/8" NPT x 3/8" BARB)	3	37	000-149-025	THERMOSTAT, BULB & CAPILLARY	1
12	000-052-104	INSERT, #66 (3/8" NPT x 3/8" BARB)	1	38	000-131-131	TRIMLOK, 3/8" x 1/8" RUBBER	1
13	000-052-105	INSERT, #68 (3/8" NPT x 1/2" BARB)	2	39	000-169-0171	VALVE, 3-WAY BALL O-RING STYLE	1
14	000-052-096	INSERT, #F23 (1/8" FPT x 3/16" BARB)	1	40	000-169-064	VALVE, 3/8" NPT FULL PORT BALL	1
15	000-081-415	LABEL SET, BOXXER 318	1	41	000-169-160	VALVE, CHEMICAL METERING	1
16	000-074-030	METER, CHEMICAL FLOW RAW	1	42	000-169-236	VALVE, DIFFERENTIAL	1
17	000-074-170	METER, RECTANGULAR HOUR w/o BEZEL	1	43	000-174-001	WASHER, #10 FLAT	14
18	000-052-527	NIPPLE, 1/4" SAE x 1/4" NPT	1	44	000-174-014	WASHER, #10 LOCK	2
19	000-052-530	NIPPLE, 1/4" SAE x 1/8" NPT	1	45	000-174-007	WASHER, 1/2" FLAT	3
20	000-052-069	NIPPLE, 1/8" NPT HEX	1	46	000-174-062	WASHER, 1/2" I.D. x 3/4" O.D. x 0.010" THK	1
21	000-052-528	NIPPLE, 3/8" M JIC x 3/8" NPT	1	47	000-174-003	WASHER, 1/4" FLAT S/S	4
22	000-052-073	NIPPLE, 3/8" NPT x 1/4" NPT HEX	1	48	000-174-058	WASHER, 21/32" I.D. x 27/32" O.D. NYLON	1
23	000-094-009	NUT, 1/4"-20UNC NYLOCK	4	49	000-174-032	WASHER, 3/8" FLAT	2
24	000-094-070	NUT, 5MM HEX NYLOCK	4	50	000-174-008	WASHER, 5/8" FLAT	4
25	000-094-098	NUT, 7/16"-24UNF - 2 WAY METERING VALVE	1	51	000-174-030	WASHER, 5/8" I.D. x 7/8" O.D. x 0.010" THK	1
26	000-100-310	PANEL, DASH, STEEL - COATED	1	52	000-174-038	WASHER, 7/16" FLAT SAE	1

Figure 8-22. Differential Check Valve Assembly
000-169-236 Rev. B

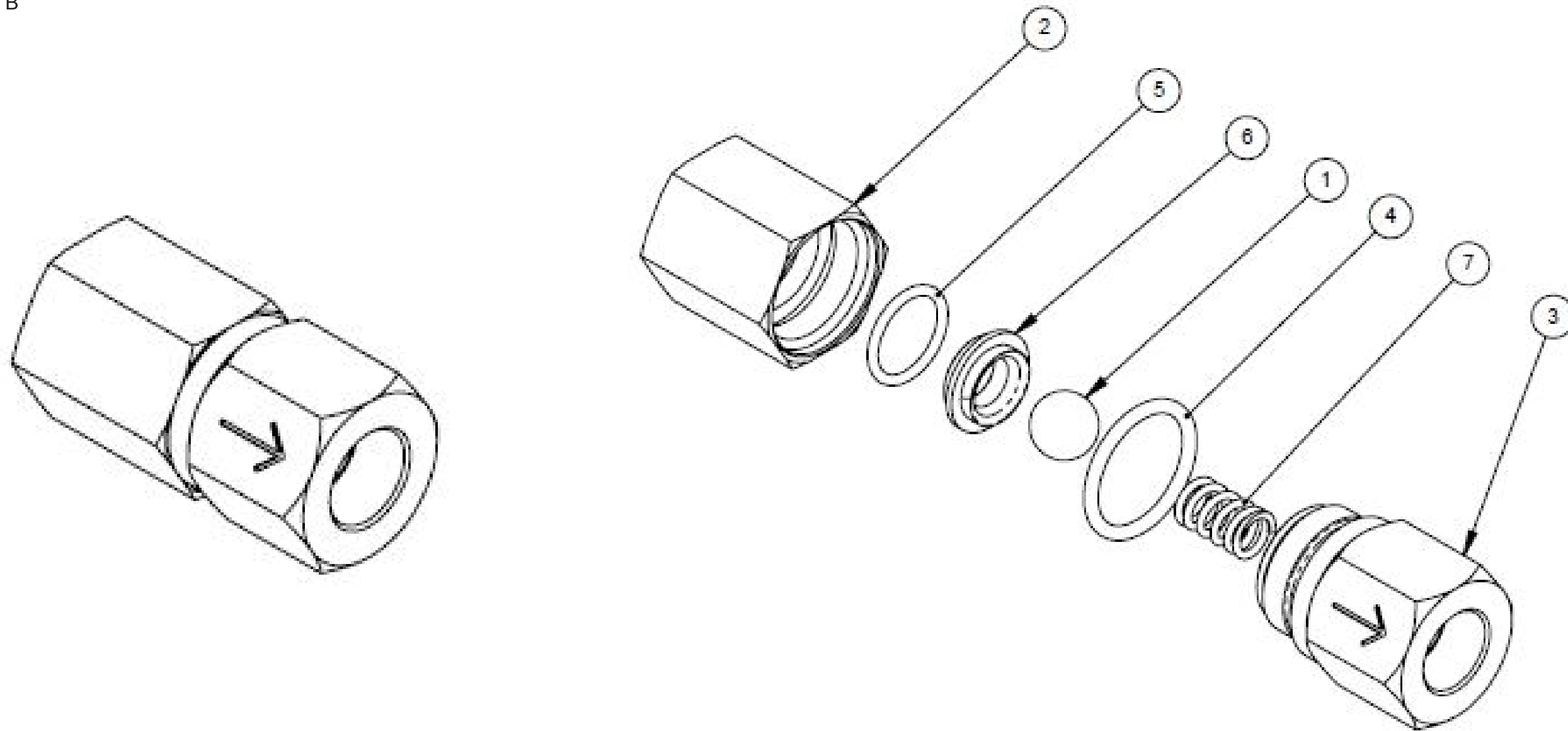

Differential Check Valve Assembly Parts List

Item	Part Number	Description	Qty
1	000-005-012	Ball, 0.500 Dia Stainless Steel	1
2	000-107-258	Body, Differential Check Valve	1
3	000-106-180	Cap, Differential Check Valve	1
4	000-097-056	O-Ring, Check Valve Plug, AN Size -118-Vit	1

Item	Part Number	Description	Qty
5	000-097-054	O-Ring, Chem. Pump Valve Viton-Parker 2-114	1
6	000-148-012	Seat, Differential Check Valve	1
7	000-155-106	Spring, Differential Check Valve	1

GTXR+

Figure 8-23. By-Pass Valve
Assembly - View 1 of 2
610-009-747 Rev. C

NOTICE

See Figure 9-1 for sealant information.

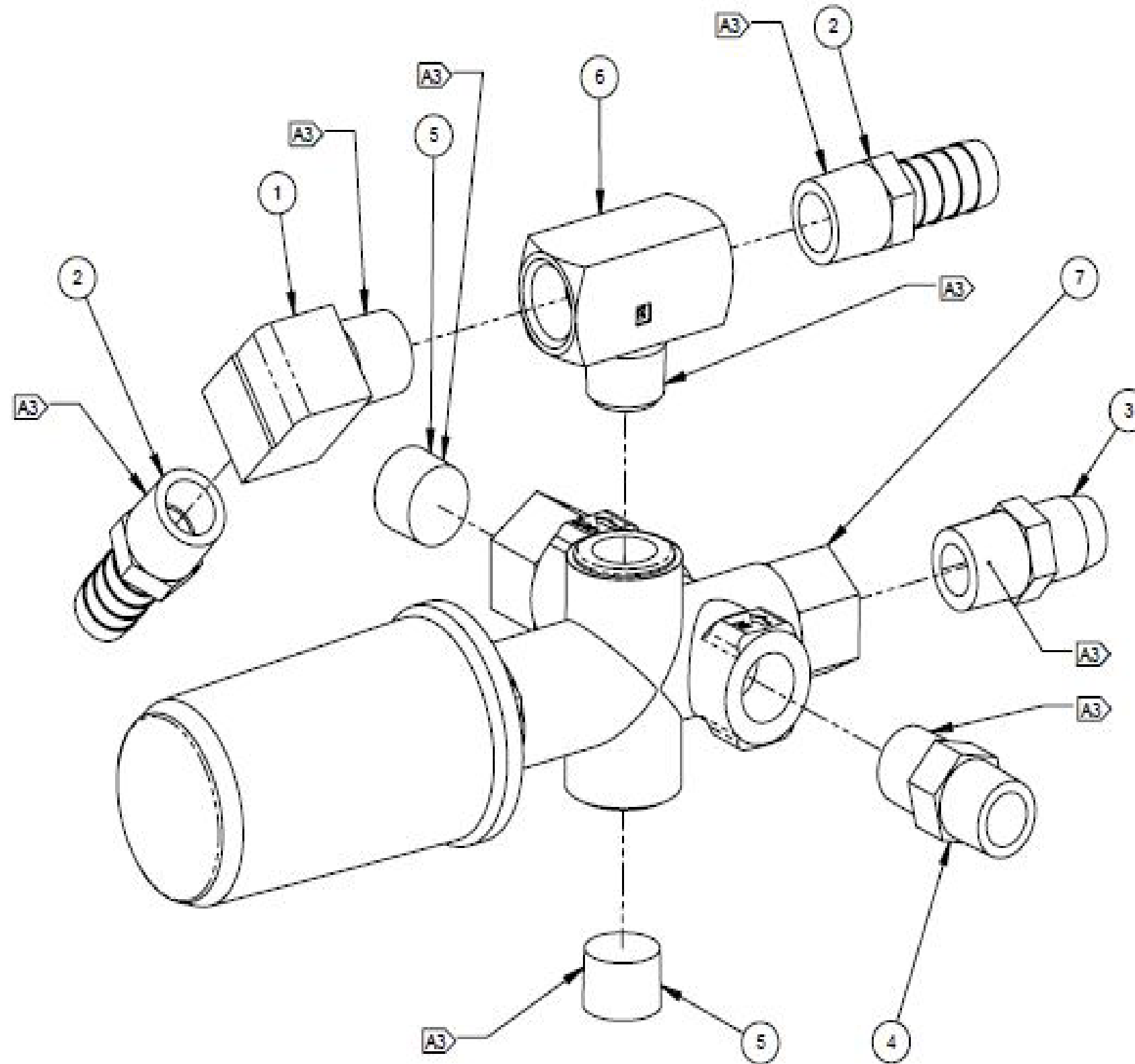

Figure 8-24. By-Pass Valve Assembly - View 2 of 2
610-009-747 Rev. C

By-Pass Valve Assembly Parts List

Item	Part Number	Description	Qty
1	000-052-086	ELBOW, 3/8" NPT STREET	1
2	000-052-105	INSERT, #68 (3/8" NPT x 1/2" BARB)	2
3	000-052-128	NIPPLE, 3/8" MPT x 3/8" SAE FLARE	1
4	000-052-074	NIPPLE, 3/8" NPT HEX	1
5	000-106-008	PLUG, 3/8" NPT ALLEN HEAD	2
6	000-052-447	TEE, 3/8" NPT MALE BRANCH	1
7	000-169-351	VALVE, PRESSURE REGULATOR-MODIFIED	1

NOTICE

* Order P/N 000-078-582 for the valve repair kit.

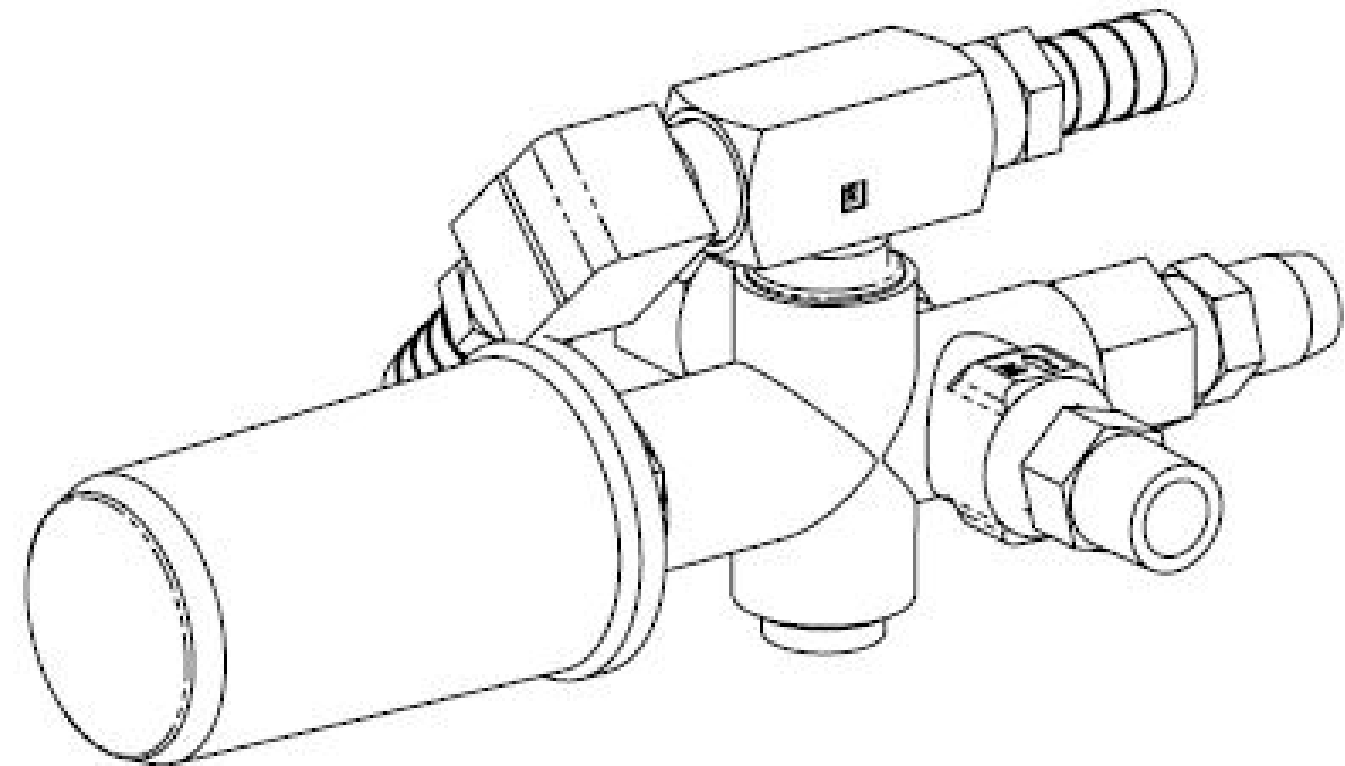
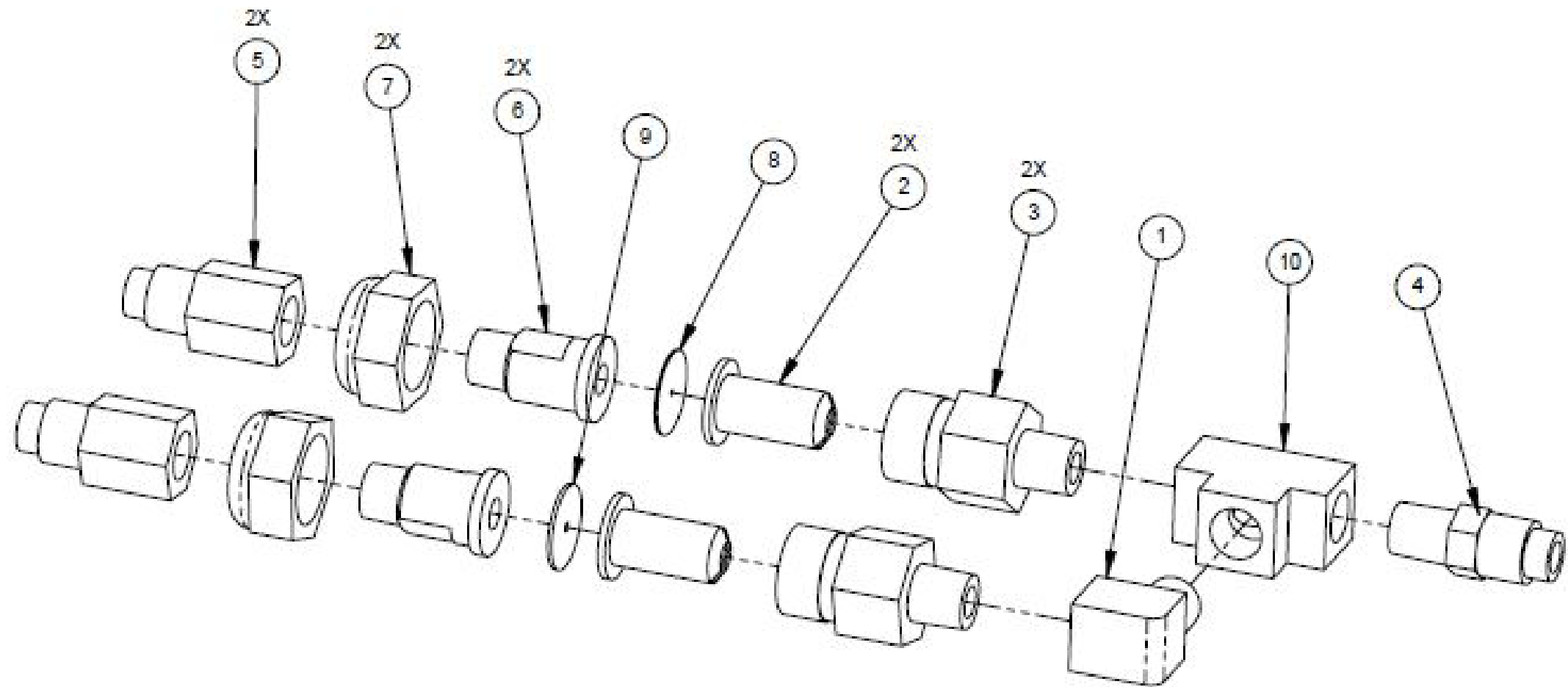

Figure 8-25. Hi-PSI Manifold
Assembly - View 1 of 2

610-021-729 Rev. -

NOTICE

See Figure 9-1 for sealant information.



**Figure 8-26. Hi-PSI Manifold
Assembly - View 2 of 2**

610-021-729 Rev. -

Hi-PSI Manifold Assembly Parts List

Item	Part Number	Description	Qty
1	000-052-084	ELBOW, 1/8" NPT STREET	1
2	000-049-052	FILTER CARTRIDGE, 1/4" BRASS	2
3	000-052-153	HOUSING, STABILIZER NOZZLE	2
4	000-052-530	NIPPLE, 1/4" SAE x 1/8" NPT	1
5	000-052-586	NIPPLE, 1/8" FPT X 1/4" SAE	2
6	000-052-582	NIPPLE, TEE JET STYLE COLLAR X 1/8" NPT	2
7	000-094-028	NUT, BRASS JET ASSEMBLY	2
8	000-180-010	ORIFICE, 0.039" PLATE	1
9	000-180-024	ORIFICE, PLATE 0.067"	1
10	000-052-092	TEE, 1/8" FPT	1

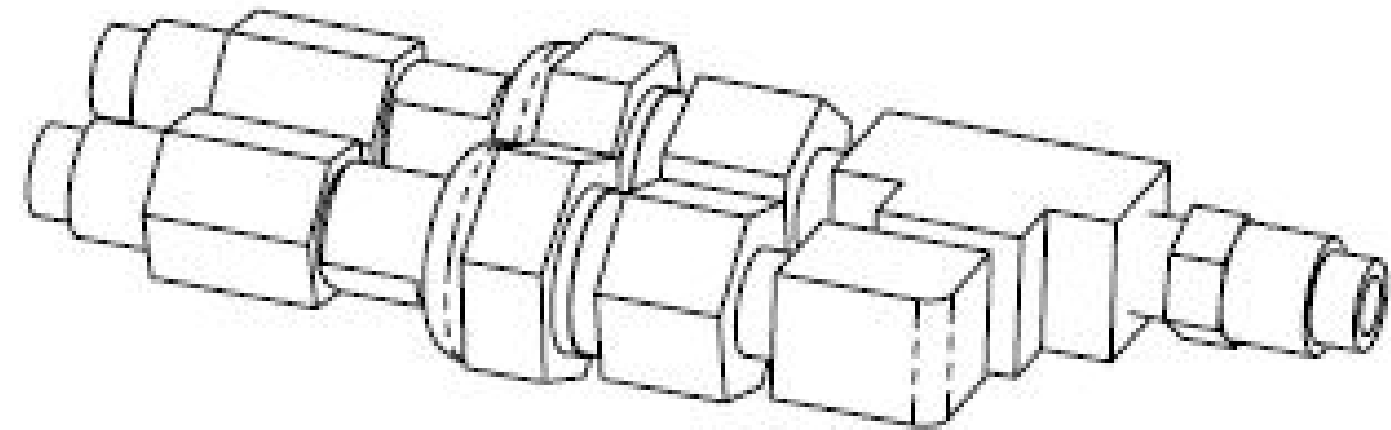
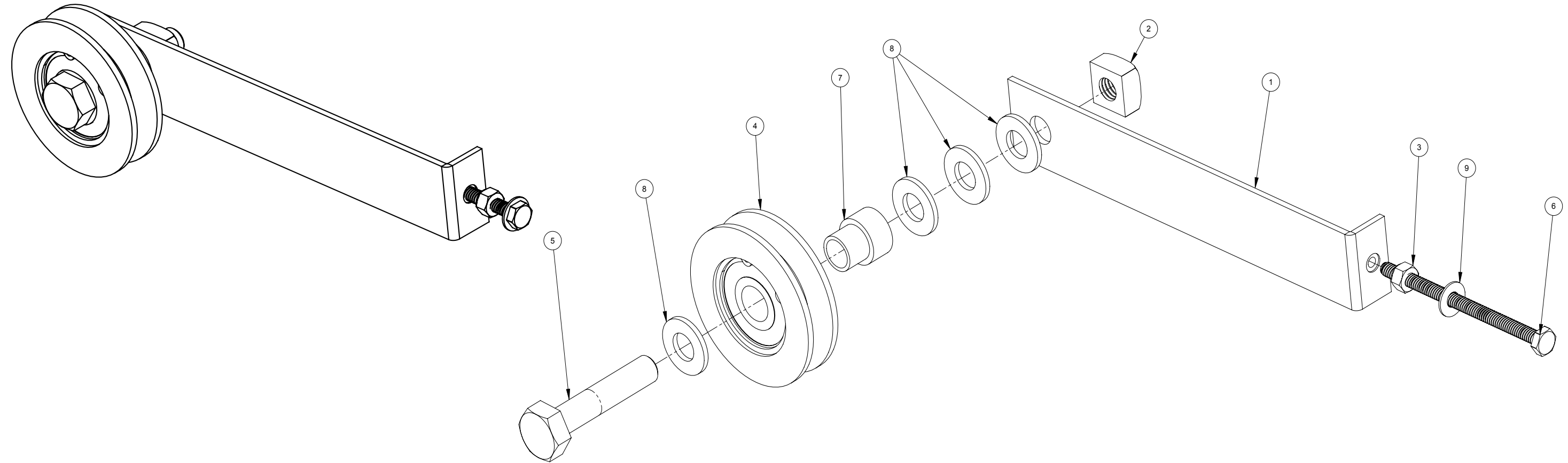

Figure 8-27. Idler Pulley Assembly
610-021-009 Rev. C



Idler Pulley Assembly Parts List

Item	Part Number	Description	Qty
1	000-015-942	Bracket, Idler Tension - Coated	1
2	000-094-119	Nut, 1/2-13UNC Zinc Plated Square	1
3	000-094-009	Nut, 1/4"-20UNC Nylock	1
4	000-109-093	Pulley, 3" "A" Sect. Ball Bearing Assembly	1
5	000-143-716	Screw, 1/2-13UNC X 2-1/2" HHC	1
6	000-143-376	Screw, 1/4-20UNC X 4" Lg. S/S- Full Thread	1
7	000-154-049	Spacer, Pump Idler Mounting - Coated	1
8	000-174-012	Washer, 1/2 SAE H/D	4
9	000-174-003	Washer, 1/4" Flat	1

Figure 8-28. Exhaust Assembly
610-013-754 Rev. B

Exhaust Assembly Parts List

Item	Part Number	Description	Qty
1	000-001-116	ADAPTER, n1.50" F SLIP TO FLARE	1
2	000-033-068	CLAMP, 1-1/2" EXHAUST	1
3	000-105-181	FLANGE, Ø1.50" EXHAUST DONUT - COATED	1
4	000-057-199	GASKET, EXHAUST DONUT	1
5	000-057-010	GASKET, EXHAUST MANIFOLD - VANGUARD	2
6	000-057-212	GASKET, HALF DONUT	1
7	000-057-209	GASKET, Ø2.5" x 3.5" BCD	1
8	000-090-001	MANIFOLD EXHAUST - WELDMENT	1
9	000-094-081	NUT, 5/16"-18UNC HEX 2 WAY LOCKING	6
10	000-143-001	SCREW, 1/4"-20UNC x 0.75" LG. HEX HEAD	4
11	000-143-124	SCREW, 5/16"-18UNC x 1.75" LG. HEX HEAD	4
12	000-125-954	TUBE, EXHAUST 8.75" LG. w/ FLARE	1
13	000-125-259	TUBE, LOWER EXHAUST - WELDMENT	1
14	000-174-003	WASHER, 1/4" FLAT S/S	4
15	000-174-019	WASHER, 1/4" LOCK S/S	4
16	000-174-049	WASHER, 5/16" FLAT	10

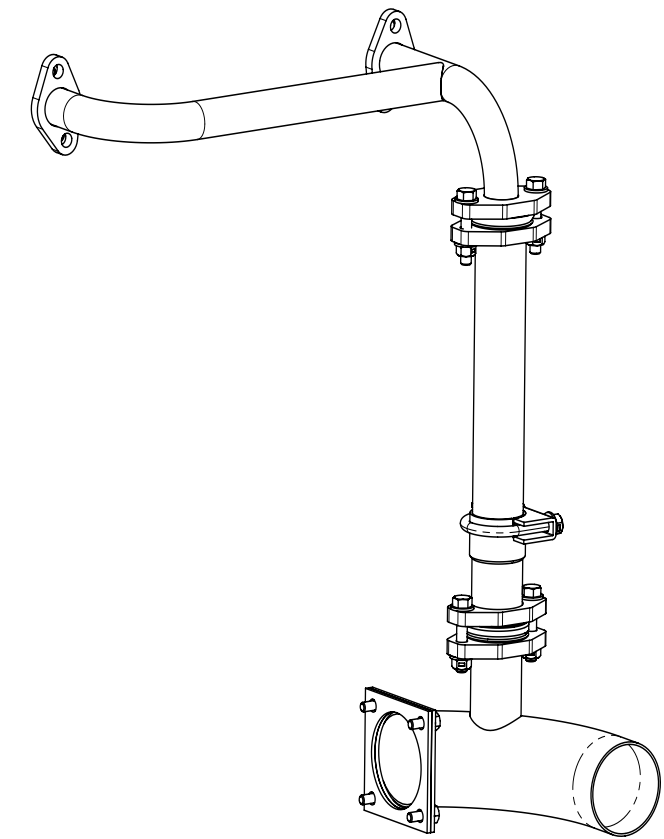
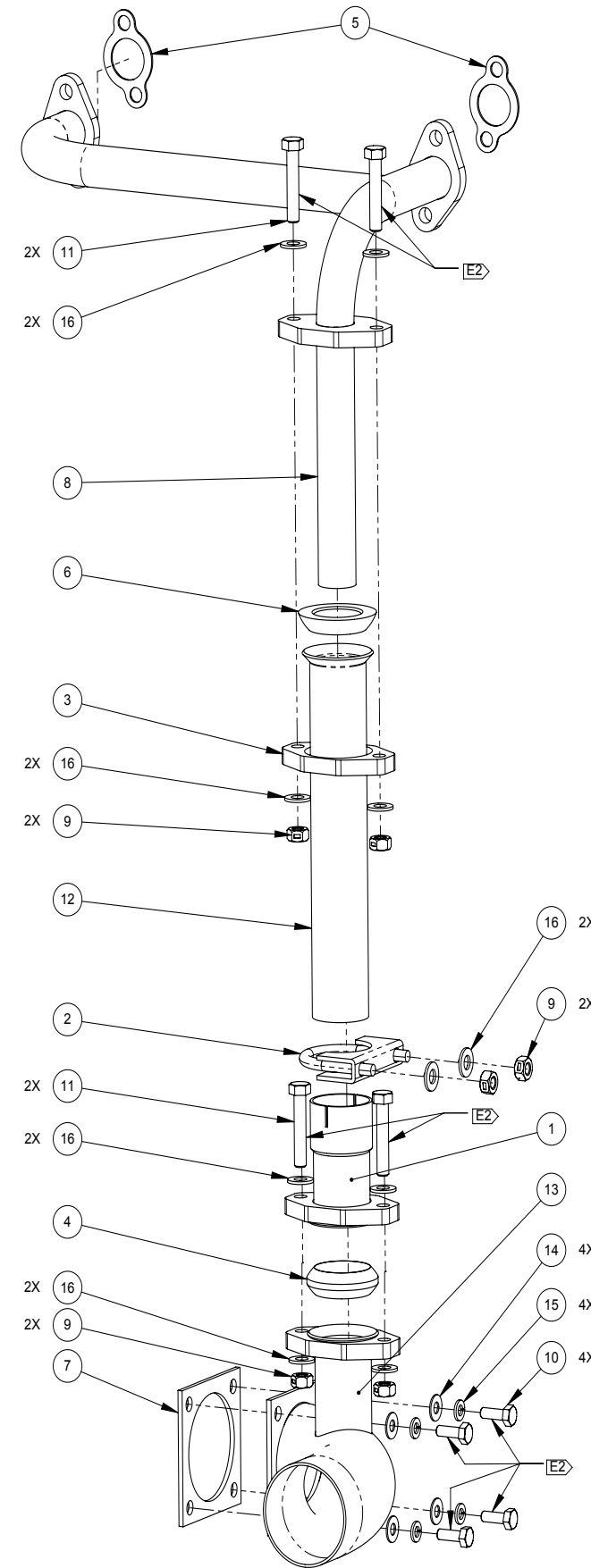

GTXR+

Figure 8-29. 70 Gallon Universal Recovery Tank (URT) Assembly
610-003-728 Rev. D

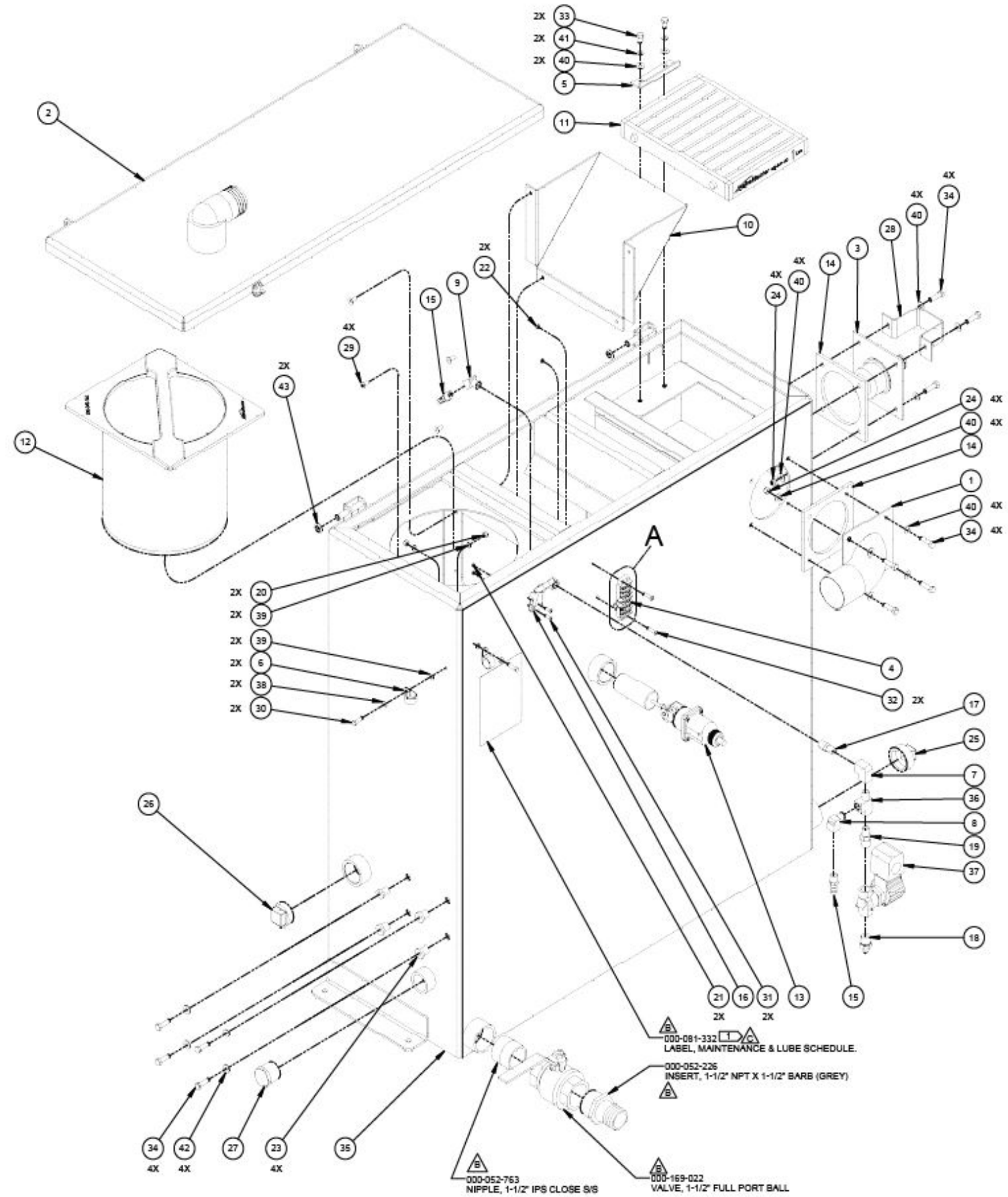

NOTICE

The AWDS is optional equipment. The lower float switch is only used when the automatic pump-out system is installed.

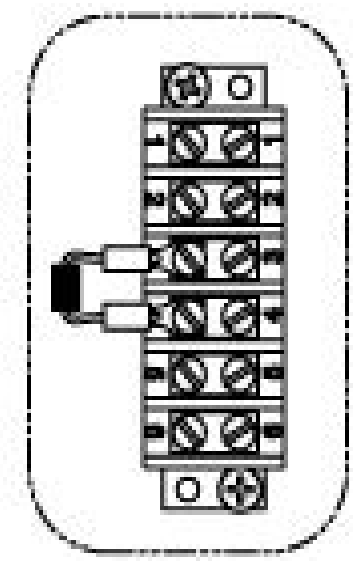

DETAIL VIEW A

70 Gallon Universal Recovery Tank (URT) Assembly Parts List

Item	Part Number	Description	Qty
1	000-001-134	Adapter, Ø2.5" Tank X 90° Blower Hose - Coated	1
2	610-029-726	Assembly, Cover, 70 Gal URT, Single Vac.	1
3	610-026-724	Assembly, Vacuum Relief Valve - URT	1
4	000-012-002	Block, 6 Post Terminal	1
5	000-015-932	Bracket, Flat Filter Securing - Uncoated	1
6	000-033-023	Clamp, 3/4" Nylon Hose	2
7	000-052-088	Elbow, 1/4" FPT X FPT	1
8	000-052-085	Elbow, 1/4" NPT Street	1
9	000-052-082	Elbow, 1/4" NPT Street X 45°	1
10	000-049-154	Filter, Air Deflector, URT - Fabricated	1
11	000-049-153	Filter, Flat - Universal Recovery Tank	1
12	000-049-152	Filter, Recovery Tank Basket	1
13	000-157-091	Float, Lever Switch	1
14	000-057-206	Gasket, Adapter - URT	2
15	000-052-102	Insert, #46 (1/4" NPT X 3/8" Barb)	2
16	000-086-008	Latch, Bungee	1
17	000-052-071	Nipple, 1/4" NPT Hex	1
18	000-052-662	Nipple, 3/8" NPT X 1/4" M SAE	1
19	000-052-073	Nipple, 3/8" NPT X 1/4" NPT Hex	1
20	000-094-034	Nut, #10-24UNC Nylock	2
21	000-094-063	Nut, #6-32UNC Nylock	2
22	000-094-059	Nut, #8-32UNC Nylock	2

Item	Part Number	Description	Qty
23	000-094-113	Nut, 1/4"-20UNC Neoprene Wellnut	4
24	000-094-009	Nut, 1/4"-20UNC Nylock	8
25	000-106-019	Plug, 1-1/2" NPT *	1
26	000-106-046	Plug, 1-1/4" NPT	1
27	000-106-049	Plug, 1" NPT Black Nylon *	1
28	000-108-179	Protector, Vacuum Relief - Coated	1
29	000-140-023	Rivet, AB8-6A Aluminum Pop	4
30	000-143-132	Screw, #10-24UNC X 0.75" Lg. Hex Head	2
31	000-143-539	Screw, #6-32UNC X 0.50" Lg. Button Head	2
32	000-143-051	Screw, #8-32UNC X 3/4" Lg. Binder Head	2
33	000-143-333	Screw, 1/4"-20UNC X 0.50" Lg. Hex Head	2
34	000-143-002	Screw, 1/4"-20UNC X 1.00" Lg. Hex Head	12
35	000-159-128	Tank, 70 Gallon URT - Coated	1
36	000-052-090	Tee, 1/4" NPT Branch M-F-F	1
37	000-169-082	Valve, 12 Volt Solenoid 1,200 psi	1
38	000-174-001	Washer, #10 Flat	2
39	000-174-036	Washer, #10 Flat Rubber Backed	4
40	000-174-003	Washer, 1/4" Flat	18
41	000-174-019	Washer, 1/4" Lock	2
42	000-174-060	Washer, 1/4" Rubber Backed	4
43	000-174-029	Washer, 3/8" Rubber Backed	2

NOTICE

P/N 000-081-332 is part of label set P/N 000-081-728. Only label sets can be sold; individual labels not available for sale.

* Items 25 and 27 are not used when the AWDS is installed.

GTXR+

Figure 8-30. 70 Gallon Universal Recovery Tank (URT) Cover Assembly
610-029-726 Rev. A

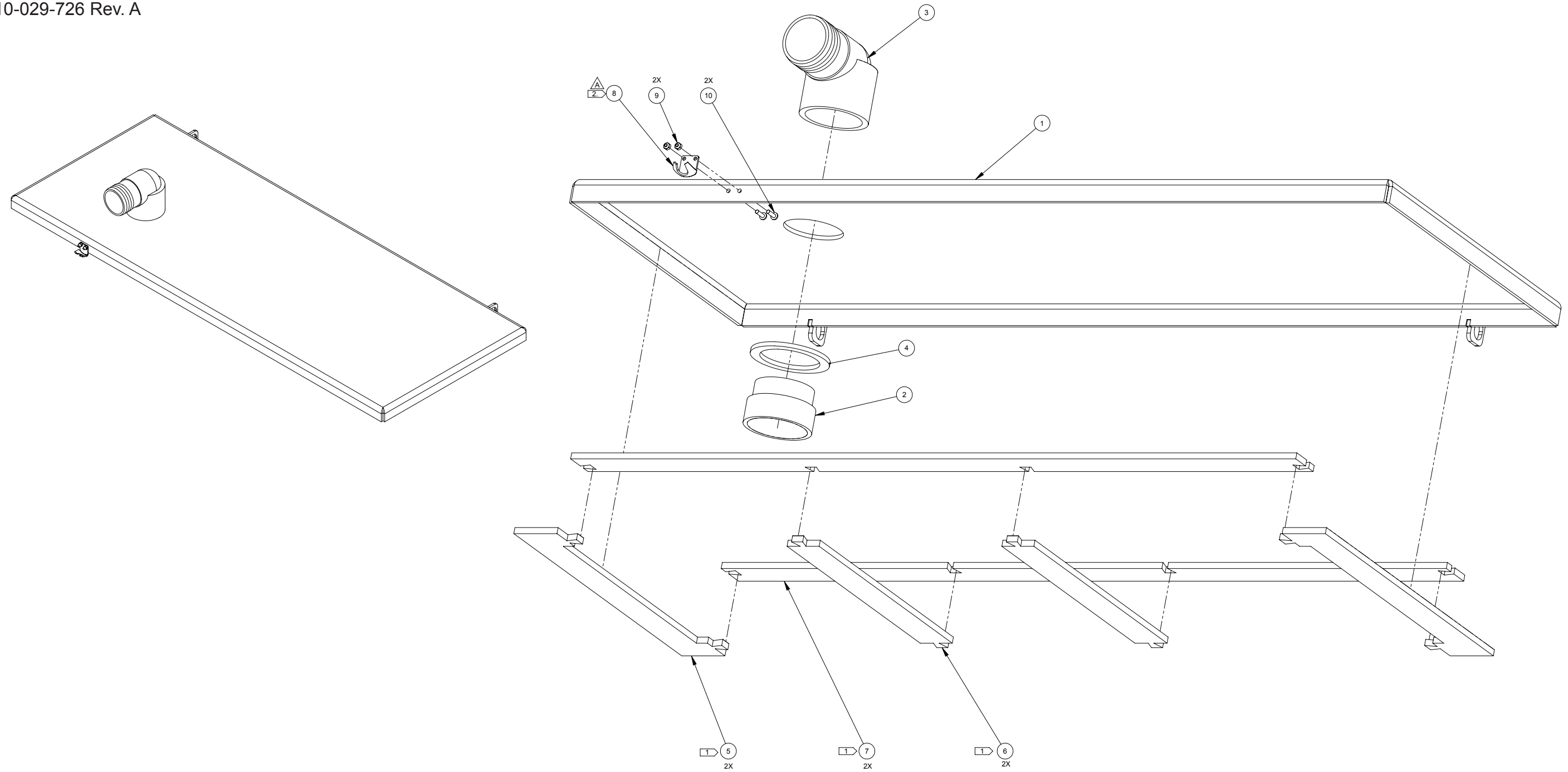

70 Gallon Universal Recovery Tank (URT) Cover Assembly Parts List

Item	Part Number	Description	Qty
1	000-041-443	Cover	1
2	000-052-219	Adapter, 2" NPT X 2" F Slip	1
3	000-052-222	Elbow, 2" Barb X 2" FPT	1
4	000-057-015	Gasket, 1-1/2" Bulkhead Fitting	1
5	000-057-202	Gasket, End - Recovery Tank Cover	2

Item	Part Number	Description	Qty
6	000-057-203	Gasket, Middle - Recovery Tank Cover	2
7	000-057-204	Gasket, Side - Recovery Tank	2
8	- - -	Latch, Bungee - Strike (Part of 000-086-008)	1
9	000-094-063	Nut, #6-32UNC Nylock	2
10	000-143-539	Screw, #6-32UNC X 0.50" Lg. Button Head	2

Figure 8-31. Vacuum Relief Valve Assembly
610-026-724 Rev. B

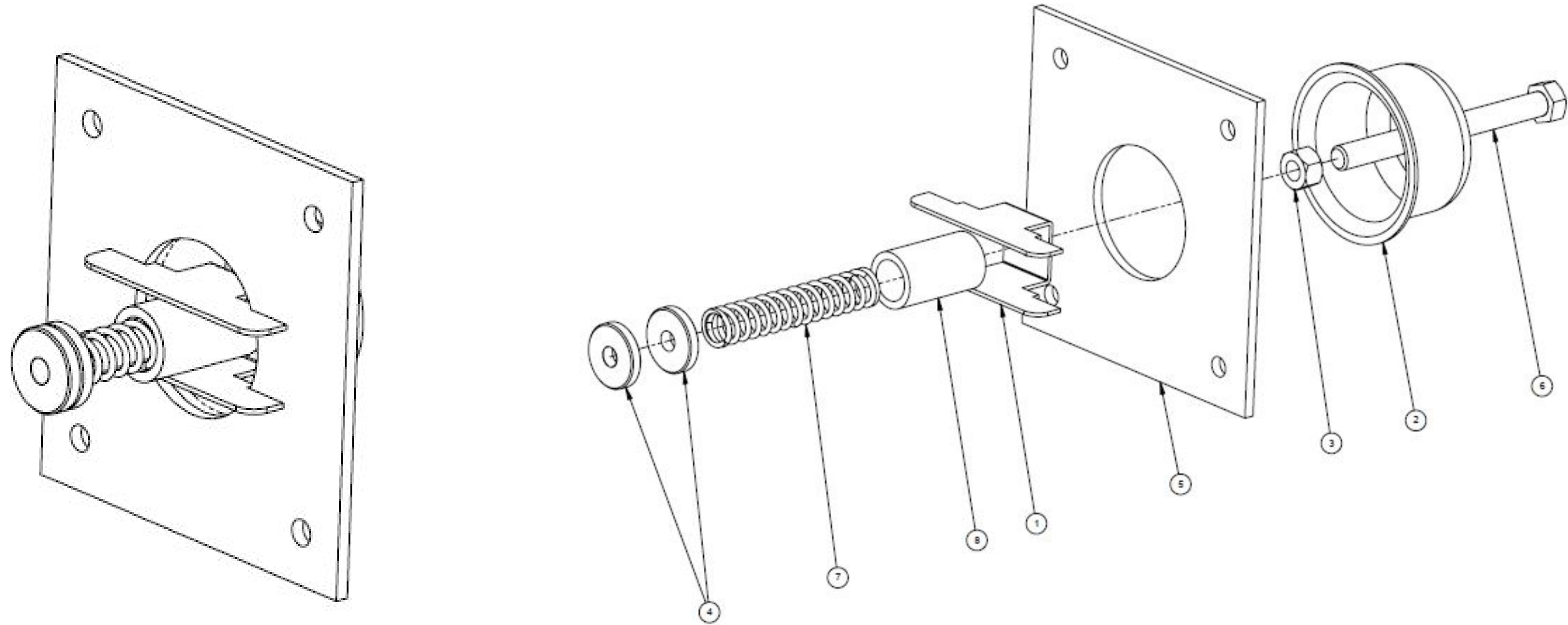

Vacuum Relief Valve Assembly Parts List

Item	Part Number	Description	Qty
1	000-015-182	Bracket, Vacuum Relief Valve - Fabricated	1
2	000-027-032	Cap, Spun Vacuum Relief Valve	1
3	000-094-101	Nut, 3/8"-16 UNC Hex Jam	1
4	000-094-077	Nut, 3/8"-16UNC X 1.00" O.D. Knurled	2

Item	Part Number	Description	Qty
5	000-105-332	Plate, Vacuum Relief Valve Mounting - Coated	1
6	000-143-198	Screw, 3/8"-16UNC X 4" Lg. Hex Head - Full Thread	1
7	000-155-026	Spring, Vacuum Relief Valve	1
8	000-125-111	Tube, Vacuum Relief Spring Guide	1

GTXR+

Figure 8-32. 70 Gallon
Fresh Water Tank (FWT) Assembly
View 1 of 2
000-163-212 Rev. B

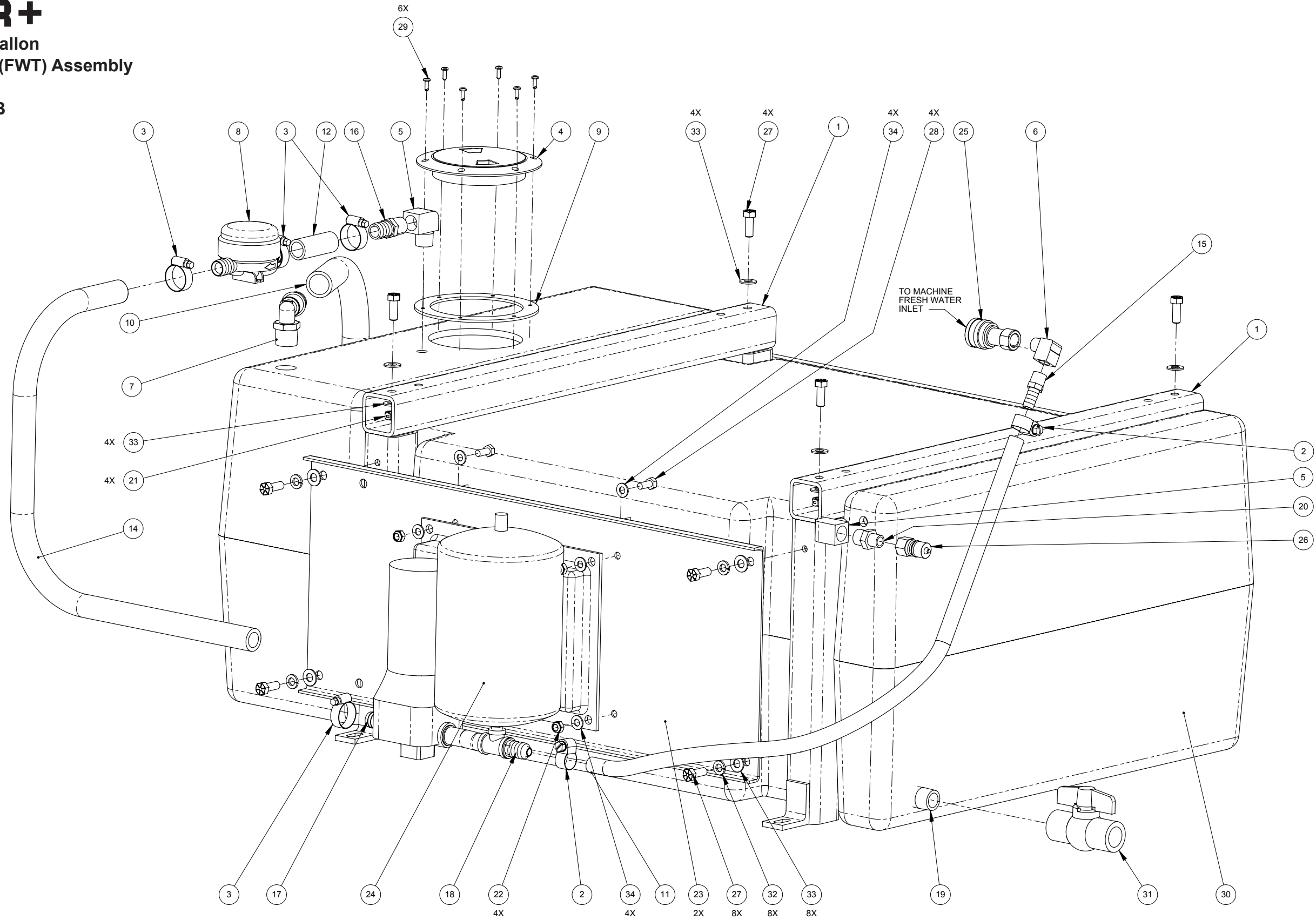
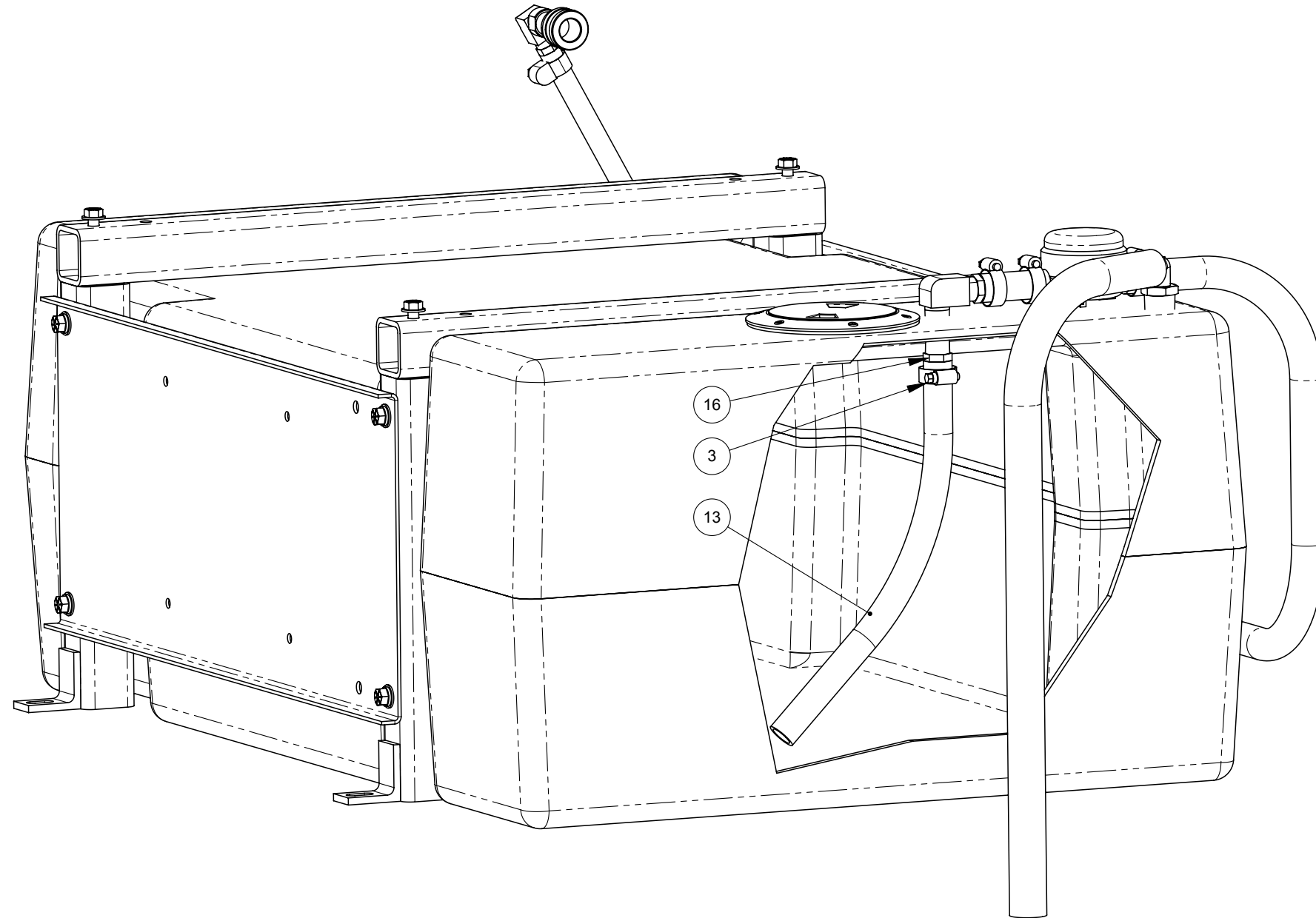

Figure 8-33. 70 Gallon
Fresh Water Tank (FWT) Assembly
View 2 of 2
000-163-212 Rev. B



70 Gallon Fresh Water Tank (FWT) Assembly Parts List

Item	Part Number	Description	Qty
1	000-015-1238	BRACKET, 70 FWT MOUNTING - COATED	2
2	000-033-004	CLAMP, SIZE #6 MINI HOSE	2
3	000-033-029	CLAMP, SIZE #12 HOSE	5
4	000-041-892	COVER, 4" ROUND POLYCARBONATE - RAW	1
5	000-052-087	ELBOW, 1/2" NPT STREET	2
6	000-052-086	ELBOW, 3/8" NPT STREET	1
7	000-052-348	ELBOW, 3/4" NPT x 1" HOSE	1
8	---	FILTER, FLOJET PUMP (COMES w\ 000-111-170)	1
9	000-057-254	GASKET - 4 IN. COVER LID	1
10	000-068-964	HOSE, 1" I.D. RUBBER x 36" LG. - RED	1
11	000-068-975	HOSE, 1/2" I.D. RUBBER x 32" LG.	1
12	000-068-973	HOSE, 3/4" I.D. RUBBER x 2.5" LG.	1
13	000-068-965	HOSE, 3/4" I.D. RUBBER x 16" LG.	1
14	000-068-974	HOSE, 3/4" I.D. RUBBER x 30" LG.	1
15	000-052-105	INSERT, #68 (3/8" NPT x 1/2" BARB)	1
16	000-052-129	INSERT, #812, 1/2NPT X 3/4 HOSE	2
17	---	INSERT, FLOJET PUMP IN (COMES w/ 000-111-170)	1

Item	Part Number	Description	Qty
18	---	INSERT, FLOJET PUMP OUT (COMES w/ 000-111-170)	1
19	000-052-326	NIPPLE, 3/4" NPT CLOSE	1
20	000-052-075	NIPPLE, 3/8" NPT x 1/2" NPT	1
21	000-094-015	NUT, 3/8"-16UNC HEX 2-WAY LOCKING	4
22	000-094-038	NUT, 5/16"-18UNC NYLOCK	4
23	000-105-668	PLATE, SIDE - COATED	2
24	000-111-170	PUMP, FLOJET W/ BLADDER 40 PSI FRESH WATER	1
25	000-052-053	QUICK CONNECT, 3/8 FEMALE	1
26	000-052-052	QUICK CONNECT, 660 3/8" BRASS W/ EPDM O-RING	1
27	000-143-018	SCREW, 3/8"-16UNC x 1" LG. HEX HEAD - GRADE 8	12
28	000-143-012	SCREW, 5/16"-18UNC x 3/4" LG.	4
29	000-143-314	SCREW, #8 x 1/2" LG. PAN HEAD	6
30	000-159-182	TANK, 70 GALLON FRESH WATER ROTOMOLDED	1
31	000-169-202	VALVE, 3/4" FPT BALL VALVE	1
32	000-174-021	WASHER, 3/8" LOCK	8
33	000-174-005	WASHER, 3/8" FLAT Z/P	16
34	000-174-049	WASHER, 5/16" FLAT	8

Hose Routings

Part No.	Description	Hose Routing	
		From	To
000-068-104	Hose, 2.5" I.D. X 2.5" Lg. Silicone	Blower	Silencer
000-068-104	Hose, 2.5" I.D. X 2.5" Lg. Silicone	Silencer	Lower Exhaust Elbow
000-068-203	Hose, 3/16" I.D. X 34" Lg.	Orifice Assembly	Water Box
000-068-517	Hose, 3/16" I.D. X 23" Lg.	Chemical Metering	Solution Out
000-068-517	Hose, 3/16" I.D. X 23" Lg.	Chemical Pump	Prime
000-068-518	Hose, 3/16" I.D. X 18.25" Lg.	Pump	Gauge
000-068-587	Hose, 3/8" I.D. Throb X 17.5" Lg.	By-Pass Valve	Heat Exchanger
000-068-627	Hose, 3/16" I.D. X 44" Lg.	Orifice Assembly	Rec Tank
000-068-724	Hose, 5/16" I.D. X 18" Lg.	Heat Exchanger	Solution Out
000-068-888	Hose, 3/16" I.D. X 24" Lg.	Heat Exchanger	Orifice Assembly
000-068-967	Hose, 1/2" I.D. Rubber X 20" Lg.	Water Box Drain	
000-068-968	Hose, 1/2" I.D. Rubber X 56" Lg.	Pump	Water Box
000-068-969	Hose, 1/2" I.D. Rubber X 69" Lg.	Fresh Water In	Water Box
000-068-970	Hose, 3/4" I.D. Rubber X 50" Lg.	Pump	Water Box
000-068-971	Hose, 3/8" I.D. Clear w/ Braid X 60" Lg.	Chemical Pump	Flow
000-068-972	Hose, 3/8" I.D. Rubber X 76" Lg.	Chemical Prime	Recovery Tank
000-068-977	Hose, 5/32" I.D. Vacuum X 82" Lg.	Blower	Vacuum Gauge
000-068-978	Hose, 5/32" I.D. Vacuum X 52" Lg.	Blower	Lube Port
000-068-979	Hose, 1/4" I.D. Fuel Low Perm X 120" Lg.	Carburetor	Fuel Hook Up
000-068-980	Hose, 3/8" I.D. Clear w/ Braid X 28.5" Lg.	Chemical Jug	Flow

10 - How to Order Parts

To order warranty replacement parts or repairs, it is important that you read this section which includes:

- Warranty Parts Orders
- Parts Orders
- Emergencies

WARRANTY PARTS ORDERS

1. Call the local distributor where you purchased your equipment and ask for the Service Department.
2. Have the following information ready:
 - a. Equipment Model
 - b. Date of Purchase
 - c. Unit Serial Number
 - d. Description of Malfunction
3. Once it has been determined which parts are needed to correct the problem with your machine, make arrangements with your distributor to either perform the repairs or ship the parts to you.

Any questions you have regarding the warranty program should be directed to the Customer Service Department at (800) 426-1301, 7 a.m. to 5 p.m. Monday through Friday (PT).

We shall always endeavor to be fair in our evaluation of your warranty claim and shall provide you with a complete analysis of our findings.

HydraMaster warranty covers only defective materials and/or workmanship for the periods listed. Diagnostic reimbursement is specifically excluded.

PARTS ORDERS

Call your local distributor. In most instances, they either stock or have access to parts through a regional service center.

EMERGENCIES

If, for any reason, your distributor is unable to supply you with the necessary parts, they may call us and arrange for expedited shipping.

HydraMaster sells parts only through authorized distributors and service centers.

GTXR+

11 - Warranty Information

To avoid misunderstandings which might occur between machine owners and the manufacturer, we are listing causes of component failure that specifically voids warranty coverage. Such causes listed in this section shall constitute abuse or neglect.

BLOWER

- Failure to lubricate impellers daily with a HydraMaster-recommended lubricant, to lubricate bearings, to maintain proper oil levels, or to use the correct oil grade and viscosity as recommended in blower manual.
- Failure to properly maintain blower safeguard systems such as waste tank filter screen, vacuum safety relief valve and waste tank automatic shut-off system.
- Allowing foam to pass through blower.

HIGH PRESSURE WATER PUMP

- Failure to maintain proper oil level as recommended in pump manual.
- Failure to change oil in pump at recommended intervals.
- Failure to protect pump against freezing.
- Failure to maintain pump protection shut-off system.
- Failure to use water softener in hard water areas.
- Use of improper chemicals.

RECOVERY TANK

- Failure to properly maintain filtering devices in tank.
- Failure to clean tank as recommended by manufacturer.
- Failure to maintain vacuum safety release in tank.
- Use of improper chemicals.

CHEMICAL SYSTEM

- Use of improper chemical.
- Failure to use water softener in hard water area.
- Operating machine without proper chemical filter screen.
- Failure to protect against freezing.

CONTROL PANEL

- Failure to protect flowmeter and water pressure gauge against freezing.

GTXR+

VACUUM AND SOLUTION HOSES

- Failure to protect hoses against freezing.
- Failure to protect hoses against burns from engine and blower exhaust.
- Damage to hoses from being run over by vehicles.
- Kinking or cracking from failure to store or unroll hoses correctly.
- Normal wear and tear from everyday use.

CLEANING WAND AND TOOL

- Failure to protect against freezing.
- Obvious physical abuse of wand or tool.

WATER HEATING SYSTEM

- Over-pressurization of the system (recommended maximum working pressure - 1,000 psi).
- Failure to protect against freezing.

HARD WATER DEPOSITS

- Failure to use or maintain a water softening system or a properly installed magnetic-type descaler, whichever might be necessary, with machines operating in designated "Hard Water Areas" (3.0 grains or more per gallon).

WARRANTY PROCEDURE

Warranty coverage is available to you through your local distributor.

If you have moved to a new area or have purchased a used machine and need information regarding your local distributor, call HydraMaster at (800) 426-1301 or email us at: techsupport@hydramaster.com.

When calling your distributor, be sure to have the machine's information; model and serial number, ready for the service representative.

HYDRAMASTER® STANDARD SLIDE-IN LIMITED WARRANTY

HydraMaster warrants to the original end user, each new machine, new accessories and genuine replacement parts against defects in material and workmanship under normal use and service. Our obligation under this warranty is limited to repair or replacement of the defective item at our factory or by an Authorized Service Center. Warranty coverage shall begin on the date of purchase by the original end user (as evidenced by your invoice from the factory or Authorized Dealer) or six (6) months from the date the machine was shipped from the factory, whichever is earlier. The warranty registration card must be completed and returned within 30 days of purchase. The warranty coverage period is specified below.

GROUP	Parts^{1,2}	Labor²
Frame	3 Years	2 Years
Covers	3 Years	2 Years
Vacuum Recovery Tank (Structural only)	3 Years	2 Years
Vacuum Pump – see Note 3	2 Years	2 Years
Chemical Systems	2 Years	2 Years
Hoses, Internal Machine	2 Years	2 Years
Hoses, External Machine	2 Years	2 Years
Valve, High pressure bypass	2 Years	2 Years
Water Heating System	2 Years	2 Years
Pump, High pressure water	2 Years	2 Years
Belts	2 Years	2 Years
Fittings, internal machine	2 Years	2 Years
Filter Screens	2 Years	2 Years
Gauges	2 Years	2 Years
Electrical Components	2 Years	2 Years
Engine	See Note 3	2 Years
Accessories and Fresh Water Tanks	1 Year	1 Year
Replacement Parts – see Note 4	90 Days	NA
NOTES:		
1-Parts repaired or replaced are guaranteed for the remainder of the original machine warranty period.		
2-Coverage only applicable to products sold and used in the United States and Canada.		
3-As provided by the original Manufacturer.		
4-Applies to replacement parts only after machine warranty coverage has expired.		

This warranty shall not apply to repairs resulting from accidents or misuse, damage in transit, overloading the capacity of the machine, failure due to lack of proper maintenance or care as described in the operating and maintenance instructions. Freezing of any water or chemical related component will VOID all warranties on water or chemical related components, internal or external. Corrosion, deposits and/or build-up in the water, chemical, recovery or heating systems due to hardness in the water used or chemicals which result in deposits, will VOID all warranties on affected components. The use or application of any chemical, including but not limited to acids or solvents, which results in damage to metal, rubber, plastic, or painted parts will VOID all warranties on those parts. Minor adjustments, such as tightening of screws or bolts not connected with the replacement of parts, are not covered. Replacement of expendable wear items including, but not limited to paint, labels and other cosmetic parts are also not covered. Repairs or alterations by an organization other than the factory or an Authorized Service Center are not covered and will void any HydraMaster warranty as to the parts or systems repaired or altered by a non-authorized organization.

THERE ARE NO WARRANTIES THAT EXTEND BEYOND THE DESCRIPTION OF THE LIMITED WARRANTIES STATED WITHIN. NO OTHER WARRANTY, EXPRESSED OR IMPLIED, INCLUDING BUT NOT LIMITED TO ANY IMPLIED WARRANTY OF MERCHANTABILITY OR FITNESS FOR A PARTICULAR PURPOSE, IS MADE EXCEPT AS EXPRESSLY STATED HEREIN. ANY STATUTORY IMPLIED WARRANTIES, INCLUDING ANY WARRANTY OF MERCHANTABILITY OR FITNESS FOR A PARTICULAR PURPOSE, THAT ARE IMPOSED BY LAW DESPITE THE EXPRESS LIMITATION OR WARRANTIES ABOVE, ARE EXPRESSLY LIMITED TO THE DURATION OF THE WRITTEN WARRANTY. BUYER UNDERSTANDS, ACKNOWLEDGES AND AGREES THAT THE REMEDIES PROVIDED UNDER THIS LIMITED WARRANTY ARE THE SOLE AND EXCLUSIVE REMEDIES AVAILABLE TO THE BUYER. HYDRAMASTER WILL NOT BE LIABLE FOR ANY OTHER OR ADDITIONAL DAMAGES, INCLUDING BUT NOT LIMITED TO INDIRECT, SPECIAL OR CONSEQUENTIAL DAMAGES ARISING OUT OF OR IN CONNECTION WITH THE FURNISHING, PERFORMANCE, USE OF OR INABILITY TO USE THE MACHINE. ANY EXTENSIONS OF OR MODIFICATIONS MADE TO THIS WARRANTY BY A DEALER/DISTRIBUTOR OF HYDRAMASTER ARE THE SOLE RESPONSIBILITY OF THE DEALER/DISTRIBUTOR.

HydraMaster will pay all freight and transportation charges within the United States, via normal ground shipping means, for replacement of parts covered under this warranty. All material must be properly authorized by HydraMaster prior to being returned. When returning, please provide an explanation of the problem and include the serial number of the machine as well as the name of the selling organization. All defective material must be returned to HydraMaster within 60 days of authorization. The Technical Service department of the authorized Dealer Service Center or the factory will investigate and then contact you.

Transportation of hazardous waste or contaminated equipment is subject to various laws and regulations. In returning machines, parts, or accessories under this limited warranty, the end user must certify in writing that the machines, parts or accessories being returned have not been used for handling, clean up, or disposal of hazardous waste or hazardous materials including but not limited to such things as asbestos, anthrax etc. or if the machines, parts or accessories being returned have been used for handling, clean up, or disposal of hazardous waste or hazardous materials, then the end user must have the machines, parts or accessories decontaminated by licensed and qualified decontamination professionals and provide written certification of this decontamination signed by the decontamination professionals. These machines, parts or accessories are to be returned only to the local HydraMaster Authorized Service Center for Warranty service along with decontamination certification.

HydraMaster reserves the right to change its warranty policy without notice.

HydraMaster is a Nilfisk, Inc. brand.

12 - Accessories and Chemical Solutions

HydraMaster's machine accessories are the most innovative collection available in the cleaning industry. For example, our RX-20® has changed the shape of steam cleaning. In addition, our hoses, reels and tanks are of the finest quality construction.

Our carpet care and hard floor care chemical solutions have been specially prepared, not only to give you exceptional cleaning, but also to optimize your truckmount's operation and reliability. HydraMaster's chemical solutions will help maintain your machine's water pump and water heating systems at peak efficiency and also help ensure fewer breakdowns.

HydraMaster's full line of machine accessories and chemicals can enhance cleaning performance while reducing your labor costs, and include:

- Upholstery Tools
- Wands
- Vacuum Hoses
- Tanks
- Van Accessories
- Hose Reels
- Carpet Care Detergents
- Rinse Agents
- Pre-Sprays
- Hard Floor Care Detergents
- De-Foamers and Descalers
- Deodorizers and Disinfectants
- Spotting Agents

For more information about our full line of accessories and chemical solutions, refer to the HydraMaster website at <http://www.hydramaster.com>.

To order genuine HydraMaster accessories and chemical solutions, call your nearest authorized HydraMaster Distributor.

GTXR+

