

CTS 450 Hot Carbonating Truckmount System™

Manufactured Exclusively for
By

ChemDry®

HydraMaster

Mukilteo, Washington

Machine Serial Number _____

Copyright © 2012
HydraMaster Corporation

No Part of this manual may be reproduced or used in any form or by any means (i.e. graphic, electronic, photocopying or electronic retrieval systems) without written permission by HydraMaster® Corporation. All Rights Reserved.

Revised March 23, 2012

Table of Contents

Table of Contents

List of Figures

Quick Reference

GENERAL INFORMATION..... Section 1

Telephone Numbers..... 1-2

Precautions..... 1-3

Responsibilities..... 1-6

Vehicle Preparation..... 1-8

High Altitude Operation Preparation 1-12

Local Water Precautions..... 1-13

 Hard Water Advisory 1-13

 Hard Water Area Map 1-13

 Water Softener..... 1-13

 Waste Water Disposal Advisory 1-14

MACHINE SPECIFICATIONS..... Section 2

Machine Layout (Gas) 2-3

Machine Layout (Diesel)..... 2-4

Component Descriptions 2-5

OPERATING INSTRUCTIONS Section 3

Start Up (Gas and Diesel Versions)..... 3-1
Carpet or Upholstery..... 3-2
Flood Extraction..... 3-2
Solution Fill Procedure..... 3-3
Shut Down 3-3
Safety Shutdown..... 3-4
General Operating Information 3-4

MACHINE MAINTENANCE Section 4

Engine..... 4-1
Air Filter 4-1
Engine Oil and Filter Change..... 4-2
Engine Coolant 4-3
Spark Plug Replacement (Gas Engine Only) 4-3
Fuel Filter (Gas Only) 4-4
Fuel Separator (Diesel Engine) 4-4
Blower..... 4-5
Blower Oil Change..... 4-5
Recovery Tank..... 4-6
Solution System..... 4-8
Orifice Manifold..... 4-8
General Maintenance 4-9
Freeze Guard Information..... 4-9
Maintenance Logs

MACHINE ASSEMBLIES AND PARTS LIST Section 5

WATER AND CHEMICAL SYSTEM Section 6

ELECTRICAL SYSTEM Section 7

WARRANTY INFORMATION..... Section 8

Limited Warranty Plan 8-2

List of Figures and Tables

Fig. 1-1	Plywood Installation	1-8
Fig. 1-2	Astroturf and Roof Vent Installation	1-8
Fig. 1-3	Recommended Placement	1-9
Fig. 1-4	Installation Using Tie-down Cleats.....	1-10
Fig. 1-5	Hard Water Map.....	1-15

Figures 2-1 through 2-6 are photos relating to machine specifications

Figures 3-1 through 3-4 are photos relating to operating instructions

Figures 4-1 through 4-15 are photos relating to machine maintenance

Machine Assemblies and Parts Lists	5-1	
Fig. 5-1	Machine Assembly - Front View	5-1
Fig. 5-2	Machine Assembly - Rear View	5-2
Fig. 5-3	Machine Assembly - Side View.....	5-3
Fig. 5-4	Frame Assembly	5-5
Fig. 5-5	Dash Assembly - Front View.....	5-7
Fig. 5-6	Dash Assembly - Rear View	5-8
Fig. 5-7	Brow Assembly - Front View	5-10
Fig. 5-8	Brow Assembly - Rear View.....	5-11
Fig. 5-9	Compressor Regulator Assembly	5-13
Fig. 5-10	Engine Assembly - Right View	5-15
Fig. 5-11	Engine Assembly - Left View	5-16
Fig. 5-12	Exhaust Assembly.....	5-20

Fig. 5-13	Air Cleaner Assembly.....	5-20
Fig. 5-14	Air Compressor Assembly	5-21
Fig. 5-15	Compressor Check Valve Assembly	5-25
Fig. 5-16	Blower Assembly - CTS 450 Gas.....	5-26
Fig. 5-17	Dump & Vacuum Bracket Assembly - Front.....	5-28
Fig. 5-18	Dump & Vacuum Bracket Assembly - Rear	5-29
Fig. 5-19	Coolant Heat Exchanger Assembly	5-31
Fig. 5-20	Blower Exhaust Heat Exchanger Assembly.....	5-33
Fig. 5-21	15 Gallon Chemical Jugs Assembly	5-35
Fig. 5-22	15 Gallon Chemical Tank Assembly.....	5-37
Fig. 5-23	100 Gallon Universal Recovery Tank Assembly	5-38
Fig. 5-24	100 Gallon Universal Recovery Tank Cover Assembly.....	5-41
Fig. 5-25	Vacuum Relief Valve Assembly.....	5-42

CTS 450 Diesel

Fig. 5-26	Machine Assembly - Front View (CTS 450 Diesel).....	5-44
Fig. 5-27	Machine Assembly - Rear View (CTS 450 Diesel).....	5-45
Fig. 5-28	Machine Assembly - Side View (CTS 450 Diesel)	5-46
Fig. 5-29	Dash Assembly - Front View (CTS 450 Diesel)	5-48
Fig. 5-30	Dash Assembly - Rear View (CTS 450 Diesel).....	5-49
Fig. 5-31	Brow Assembly (CTS 450 Diesel).....	5-52
Fig. 5-32	Frame Assembly (CTS 450 Diesel).....	5-54
Fig. 5-33	Engine Assembly - Right View (CTS 450 Diesel)	5-56
Fig. 5-34	Engine Assembly - Left View (CTS 450 Diesel).....	5-57
Fig. 5-35	Air Cleaner Assembly (CTS 450 Diesel).....	5-61
Fig. 5-36	Blower Assembly (CTS 450 Diesel).....	5-62

Fig. 6-1 Solution Flow Diagram 6-1

Fig. 7-1 Wiring Diagram CTS 450 Gas (Sheet 2) 7-1

Fig. 7-2 Wiring Diagram CTS 450 Gas (Sheet 3) 7-2

Fig. 7-3 Wiring Diagram CTS 450 Gas (Sheet 4) 7-3

Fig. 7-4 Wiring Diagram CTS 450 Diesel (Sheet 1) 7-4

Fig. 7-5 Wiring Diagram CTS 450 Diesel (Sheet 2) 7-5

Fig. 7-6 Wiring Diagram CTS 450 Diesel (Sheet 3) 7-6

Fig. 7-7 Electrical Schematic CTS 450..... 7-7

Quick Reference

Fuel Pump Assembly
B-4627 Rev-

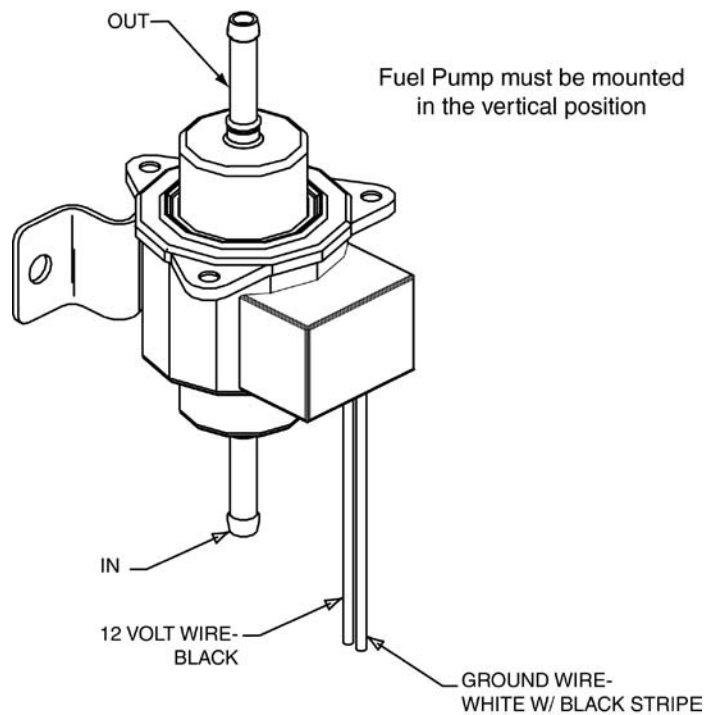

General Information

This manual contains installation and operation instructions as well as information required for proper maintenance, adjustment and repair of this unit. Since the first and most important part of repair work is the correct diagnosis of the problem, component manual troubleshooting charts have been included for your convenience.

Unlike a garden tractor, lawn mower or cement mixer, all having one or two functions to perform, the truckmounted carpet cleaning plant has many functions to perform simultaneously.

- The engine has to run at a consistent rpm.
- The vacuum has to pull air and dirty water back from cleaning site.
- The solution system provides stable pressure at proper water flow for cleaning.
- The heating system must maintain proper heat.
- The vacuum tank must store dirty water until drained.

As you can see, this machine is not just a simple turn-key operation where your only worry is “**Does it start?**”

 **WARNING**

The manufacturer uses this symbol throughout the manual to warn of possible injury or death.

 **CAUTION**

This symbol is used to warn of possible equipment damage.

Telephone Numbers

CTS Installer: _____	_____
HydraMaster/ChemDry Tech Support	(877) 282-2319
HydraMaster Customer Service	(800) 426-1301
Harris Research, Inc. Tech Support	(435) 755-0255

Hours

HydraMaster	Monday-Friday 6:00 am to 5:00 pm Pacific Standard Time
Harris Research, Inc.	Monday-Friday 8:00 am to 5:00 pm Mountain Standard Time

Precautions

 **CAUTION**

1. Engine Cooling

Units employing internal combustion engines must not be enclosed within a van with doors and windows closed. Excessive temperatures within the engine will result in premature engine failure and a compromise of applicable warranty.

 **CAUTION**

2. Level Operation

During operation, van or trailer must be parked on level ground not to exceed + or – 10 degrees. Failure to ensure proper leveling may prevent proper internal lubrication of engine, vacuum and/or high pressure components.

 **WARNING**

3. Moving Parts

Never touch any part of the machine that is in motion. Severe bodily injury may result.

 **CAUTION**

4. Freeze Protection

There is often little warning before a cold spell. Failure to protect this equipment from freezing will result in costly down time. Placing an electric heater in the truck or parking the truck indoors will help to insure against freezing, but should not be the primary method of freeze protection.

 **WARNING**

5. Exhaust System

Do not allow flammable material (i.e. oil, fuel, plastic, or wood products) to come in contact with the exhaust system.

 **WARNING**

6. Hot Surfaces

During the operation of this equipment, many surfaces on the machine will become very hot. When standing in the proximity of the van, care must be taken not to touch any hot surface such as the heater, engine, exhaust, and etc.

 **WARNING**

7. Hearing Protection

The Occupational Safety and Health Administration (OSHA) recommends the use of hearing protection when a technician is exposed to an average of 85 decibels. This is an average of exposure over an 8 hour period. This equipment can produce 85 decibels to a distance of 10 feet. Please check with your local state agencies to see if OSHA standards apply to your machine use.

 **WARNING**

8. Carbon Monoxide

This unit generates toxic fumes. Position the vehicle so that the fumes will be directed away from the job site. Do not park where exhaust fumes can enter a building through open doors, windows, air conditioning units, or kitchen fans.

 **WARNING**

9. Toxic Fumes

Do not occupy the vehicle when the cleaning equipment is operating. Toxic fumes may accumulate inside a stationary vehicle.

 **WARNING**

10. Engine Exhaust

The engine exhaust from this product contains chemicals known to the State of California to cause cancer, birth defects, or other reproductive harm.

 **WARNING**

11. Carburetor Drain

Under no circumstances should the drain in the carburetor bowl be used when the machine is hot.

 **WARNING**

12. Portable Gas Tank

Never operate this machine with a portable gas can inside the truck. Doing so increases the risk of a fire or explosion.

 **WARNING**

13. Transportation of Fuel Containers

Transportation in a vehicle of any vented fuel container that presently has or has ever contained a flammable liquid is strictly forbidden by Harris Research Inc. and by federal and state regulations.

 **WARNING**

14. Vacuum System

When machine is being run for test purposes and the vacuum inlet on top of the machine is open, caution should be used.

To protect the vacuum blower from over loading and damaging itself, there is a vacuum relief system installed on the vacuum tank. When the vacuum tank inlet is completely sealed off, a maximum of 12 inches Hg will be attained. At the end of each day, an oil based lubricant should be sprayed into the blower lubrication port before shutting down the machine. If this operation is not performed daily the vacuum blower will develop rust deposits from moisture and will decrease the life of the vacuum blower.

 **CAUTION**

15. Vacuum Tank

Foam passing through the blower could lead to equipment malfunction. Therefore, it is important to keep the vacuum tank foam free.

 **WARNING**

16. Vacuum Hose

Do not leave the vacuum hose unattended during operation. This could cause bodily injury.

Responsibilities

The **Purchaser's** responsibilities are:

Reading of Owner's Manual: It is the purchaser's responsibility to read the unit operation manual and to familiarize himself with the information contained therein. *Special attention should be paid to all **Cautions and Warnings.***

Prior to arrival of unit, install exterior plywood flooring in the vehicle and we suggest sealing with a sealer.

Purchase a heavy duty group 24 - 60 amp hour battery and have the battery 'slow' charge if new. If the battery is not fully charged, damage can occur to the engine charging regulator.

The **Equipment Installer** responsibilities are:

ACCEPTANCE OF SHIPMENT:

1. If the unit shows any outward signs of damage, do not sign the delivery receipt until you have closely inspected the unit and noted any damage on the delivery receipt.
2. The equipment installer is responsible for the correct installation of the unit in your vehicle and thoroughly training you in its operation, maintenance and precautions.

Correct Installation Includes:

- Installation of through-floor fittings for gasoline fuel lines.
- Placing the unit and recovery tank in your vehicle and securing them with bolts or tie down cleats.
- Install and connect the fuel pump.
- Connecting gasoline lines.
- Connecting the battery.
- Checking the vacuum blower and engine oil levels prior to starting the unit.
- Starting the unit to check engine and see that all systems function normally.
- Checking all hoses, wands, etc. for correct operation.

Note: Under certain circumstances, machines may require modification for optimal performance. Certain environmental conditions may require engine modification or control function calibration.

Training Shall Include:

- A thorough review of the operation manual with purchaser.
- A thorough review of the unit warranty and warranty procedures.
- Instruction and familiarization in:
 1. How to correctly start up and shut down the unit.
 2. How to correctly clean with the unit.
 3. Where and how often to check and change component oil levels.
 4. How the unit's systems work.
 5. How to troubleshoot the unit.
 6. How to do basic repairs.
 7. Safety precautions and their importance.
 8. Freezing damage and how to avoid it.
 9. Cleaning the orifices and how they function in the system.

Vehicle Preparation

The preferable vehicle for the CTS 450 Truckmount installation is either a cargo van or a minivan with a heavy-duty suspension package. The van should have a minimum 1/2 ton capacity.

Be cautious when drilling any holes through the van floor. Many vans have critical components mounted directly below the van floor that could be damaged by a misplaced drill bit.

TRUCK PREPARATION

The manufacturer recommends a spray-on bed liner or the installation of plywood flooring, in the vehicle prior to installation of machine.

This provides a metal-to-cushion mounting rather than metal-to-metal, insulation and makes an attractive van interior.

Materials Needed:

1. 2 sheets 4 x 8 x 5/8" exterior plywood
2. 1 Gallon Polyurethane Wood Sealer
3. 16 - 1½" sheet metal screws

(See **Figures 1-1 and 1-2** for correct placement of plywood flooring)

Roof Vents

Harris Research strongly recommends installing roof vents in vehicles operated in hot weather locations.

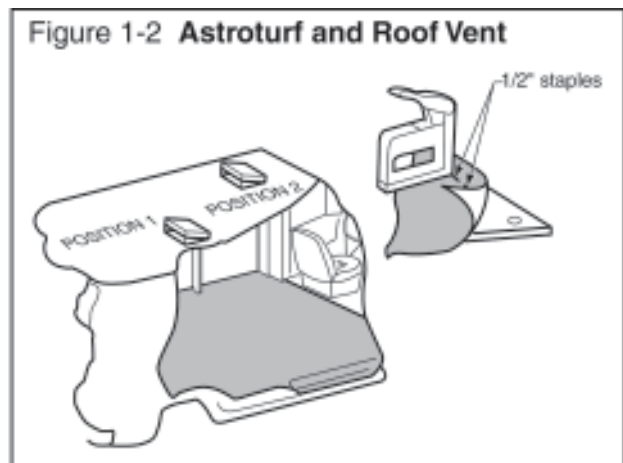
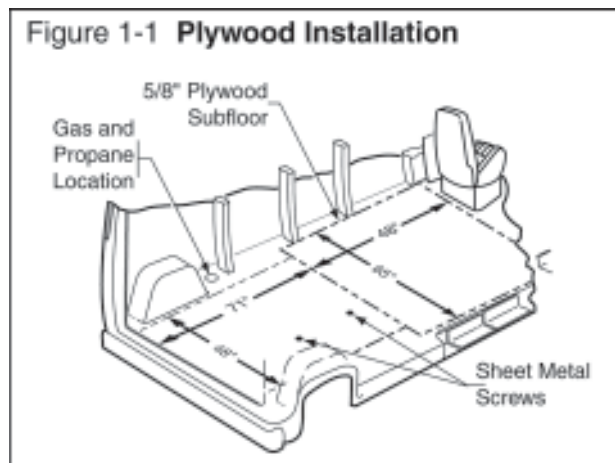

PLACEMENT OF UNIT IN VEHICLE

There are two recommended unit placements, side door and rear door. These recommended placements are described below and illustrated in **Figure 1-3**.

SIDE DOOR:

Most installations are side door. This provides rear access for accessories and hoses as well as unobstructed access to the component/working side of the machine, thus making it a bit easier to perform maintenance and/or repair without removing the unit from the truck.

REAR DOOR:

Although this location partly limits working access, it does direct the noise away from the cleaning site. Some cleaners in the colder areas prefer this location because it puts the weight over the rear wheels for better traction in ice and snow. Rear mounting requires the unit to be slid to the right side as far as possible.

This not only provides adequate working space on the component side of the unit but also improves weight distribution inside the van (engine and component weight line up over drive shaft). Also, it is physically easier to load the unit into the rear door due to the height of the van bed.

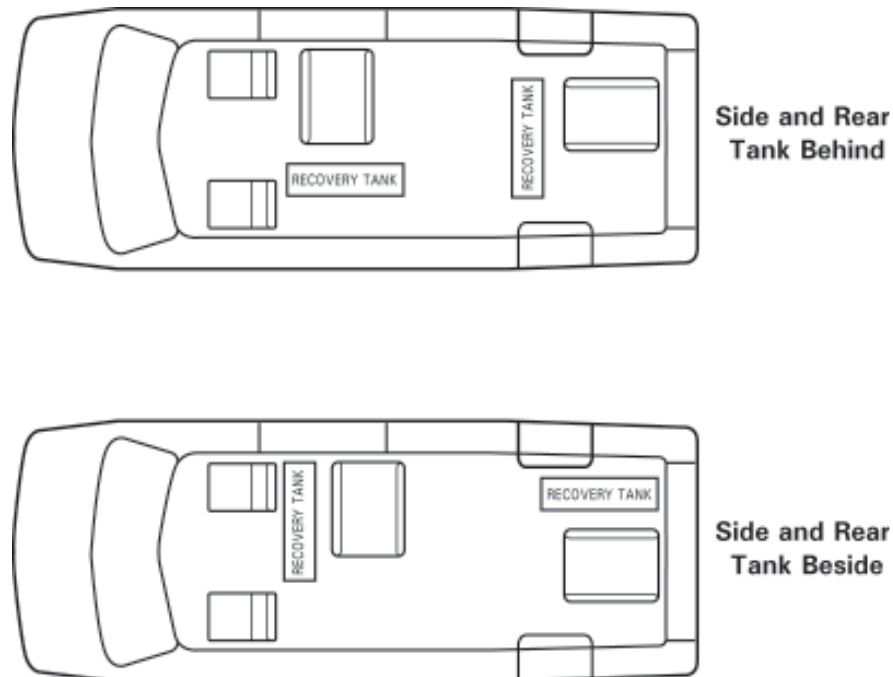

Figure 1-3 Recommended Placement

Machine Tie Down Cleats

Secure the machine to the floor of the van with the four tie down cleats provided (See **Figure 1-4**). This safety measure will ensure that the machine will not slide inside the van. See the following illustration for the correct installation.

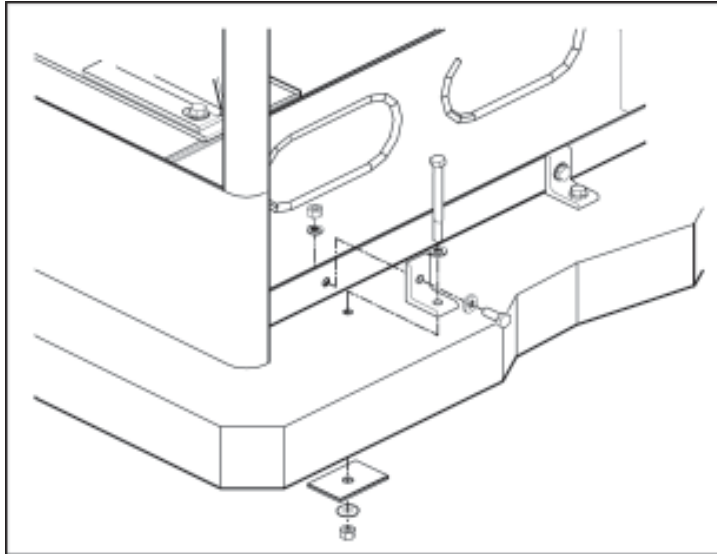

Figure 1-4 Installation Using Tie-down Cleats

WARNING

Ensure that the machine is well secured to the floor of the van with the hardware supplied. A sudden or crash stop will cause the machine to rocket forward. Protect yourself and the machine. **SECURE IT!**

WARNING

It is recommended by the manufacturer that the exhaust from the front of the machine be vented down under the truck to prevent carbon monoxide from entering the job site. **Always park the truck so the exhaust is blowing away from the job site.**

The manufacturer also recommends the installation of 12 volt powered vents in the truck roof to allow heat to escape.

WARNING

Never operate this machine with a portable gas can inside the truck. Doing so increases the risk of a fire or explosion.

Mount a fire extinguisher just inside the rear or side door for emergencies.

 **WARNING**

Do not use a portable propane tank inside of the truck or van. It is dangerous and illegal in most states.

 **WARNING**

Transportation in a vehicle of any vented fuel container that presently holds or has ever held a flammable liquid is strictly forbidden by HydraMaster Corporation and by federal and state regulation.

 **WARNING**

The engine exhaust from this product contains chemicals known to the State of California to cause cancer, birth defects or other reproductive harm.

 **WARNING**

If the battery location is at your option, first make sure it is in an approved battery container and that it is covered and secured to the floor of the vehicle. Make sure the battery is isolated from hot machine components. This will cause the battery to last longer and also prevent the possibility of fire or explosion.

High Altitude Operation Preparation

To have your machine run at its peak performance; you may have to make adjustments depending on the elevation. Elevation plays a key role in how the machine will operate.

The factory setting of the machine is set for elevations from 0—3,000 feet. Any time the machine is operated above 3,000 feet there are two areas on the machine the *may* need adjustment.

The first area is the carburetor jet. The higher the elevation, the less air is provided to the fuel mixture. This will make the engine run 'rich', and, in turn will result in the loss of power, excessive heat in the exhaust, and carbon buildup in the exhaust and heat exchanger system. The jet sizes vary per engine and elevation. Consult HydraMaster to obtain proper jet size.

The second area that may need adjustment is the heat control system. The heat control system is also optimized to 0-3,000 feet. At higher altitudes the boiling point of water is lowered. In turn, this can cause the water box to boil and the high pressure pump to cavitate. The heat control system settings will have to be adjusted to compensate for the elevation. These settings will vary according to elevation. Contact HydraMaster to obtain the recommended settings.

Local Water Precautions

The quality of water varies greatly. Many areas have an excess of minerals in the water which results in what is commonly called “hard water.” These minerals tend to adhere to the insides of heater coils and other parts of the machines causing damage and a loss of cleaning effectiveness. This influences the reliability and efficiency of equipment in direct proportion to the level of hardness.

HARD WATER ADVISORY

HydraMaster recognizes that any hard water deposits which might occur within the water system of our truckmounts is a serious problem. The precision technology of truckmount heat exchanger systems is intolerant of any foreign material. Hard water deposits will ultimately decrease the performance of the system and are expected to seriously lower the reliability of the machine.



Failure to take appropriate measures to prevent scale build up can result in **system failure** and **loss of warranty** on affected parts.

HARD WATER AREA MAP

The hard water map on page 1-15 defines areas in the United States which compromise fluid related components such as hoses, fittings, heaters, pumps, valves and water cooled engines. For other countries, hard water area maps can be obtained from geological societies.

WATER SOFTENER

Cleaning efficiency and equipment life is increased, and the appearance of cleaned carpets enhanced when water softeners are incorporated in hard water areas. The manufacturer strongly urges the use of a water softener units in areas exceeding 32 grains per gallon. Failure to use a water softener in these areas will invalidate the machine’s warranty. Using a hard water area map as a reference, determine the quality of water in your area and take action immediately, if necessary.

Reports from several of our machine users commending the results of the use of water softeners in conjunction with their machines prompts us to recommend the procedure to everyone in a “hard water” area.

The relatively low cost of a water softener service is more than made up for by an increased life of machine parts, reduced chemical costs and continued cleaning efficiency.

Contact a water softener distributor in your area for information on the rental of a simple water treatment unit to carry in your truck. Be sure to change the water softener in accordance with the capability of the softener. For example: If the softener will treat 900 gallons of water and the machine uses an average of 30 gallons per hour, for an average of 5 hours a day, this equals 150 gallons per day. In 6 days the machine would use 900 gallons of water. Therefore, the softener would need to be changed every 6 working days for maximum softening.

WASTE WATER DISPOSAL ADVISORY

There are laws in most communities prohibiting the dumping of recovered “gray” water from carpet cleaning in any place but a sanitary treatment system.

This cleaning rinse water, recovered into your unit’s vacuum tank, contains materials such as detergents. These must be processed before being safe for streams, rivers and reservoirs.

IN ACCORDANCE WITH THE EPA, STATE AND LOCAL LAWS, DO NOT DISPOSE OF WASTE WATER INTO GUTTERS, STORM DRAINS, STREAMS, RESERVOIRS, ETC.

In most cases, an acceptable method of waste water disposal is to discharge into a municipal sewage treatment system after first filtering out solid material such as carpet fiber. Access to the sanitary system can be obtained through a toilet, laundry drain, RV dump, etc. Permission should first be obtained from any concerned party or agency.

One disposal method which usually complies with the law is to accumulate the waste water and haul it to an appropriate dump site. Another solution to the disposal problem is to equip the machine with an Automatic Pump-Out System. These systems are designed to remove waste water from the extractor’s recovery system and actively pump the water through hoses to a suitable disposal drain. Properly designed, they will continuously monitor the level of waste water and pump it out simultaneously to the cleaning operation. The hidden benefit of this process is that the technician does not have to stop his cleaning to empty the recovery tank.

HydraMaster makes an A.P.O. System available which can be ordered with new equipment or installed later.

The penalties for noncompliance can be serious. Always check local laws and regulations to be sure you are in compliance.

Figure 1-5 Hard Water Map

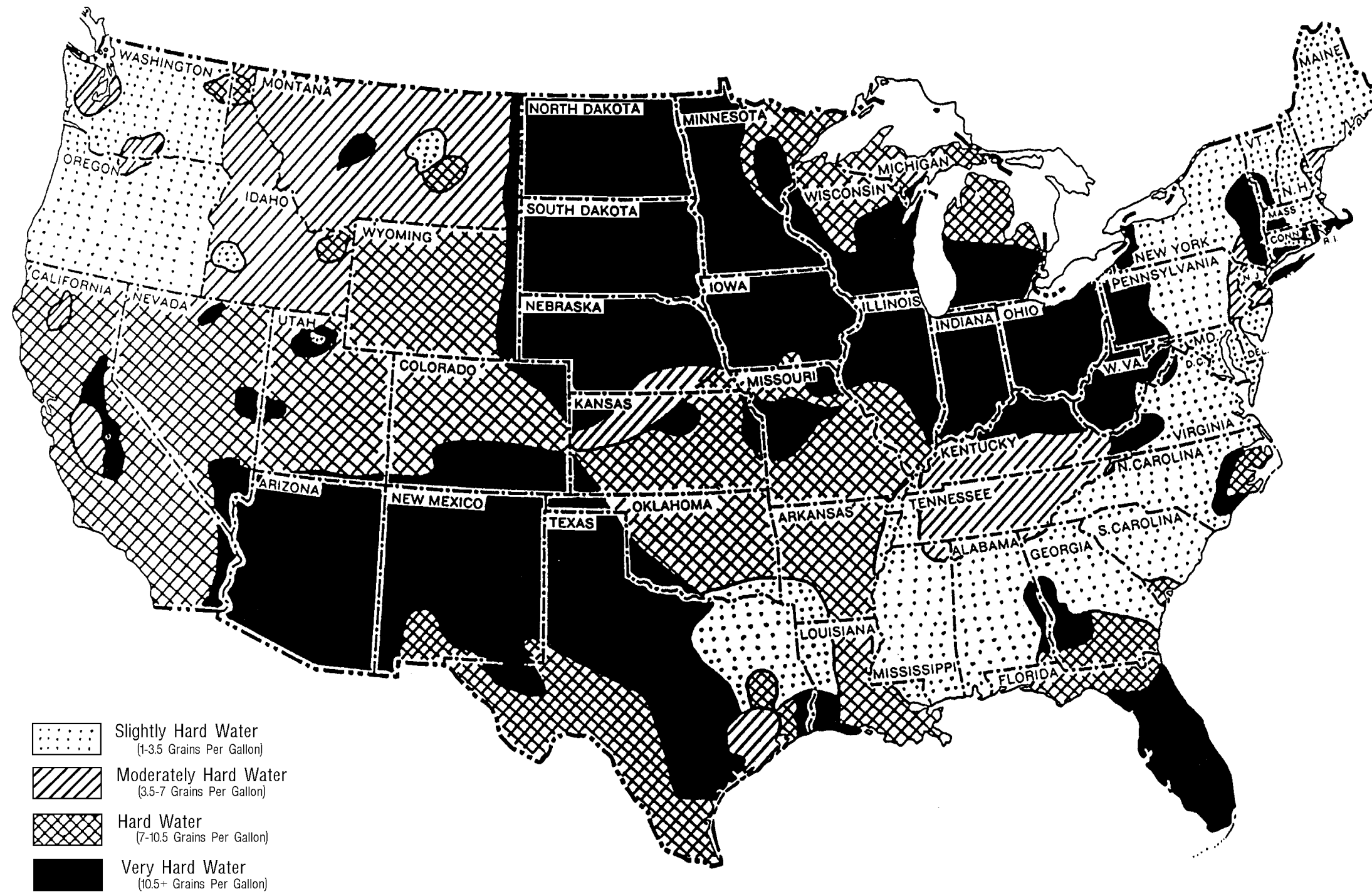

Source: Water Treatment Fundamentals, Water Quality Association, 1996.

Machine Specifications

Frame: 24.5"W x 47.75"L x 37.375"H

Weight: 600 lbs.

Engine

Gasoline: Daihatsu Liquid Cooled 3 Cylinder, Cast Iron Block
Displacement: 697cc/23.5 HP
Ignition: Electronically Triggered Coils (1 per cyl.)
12 v Electric Starter Motor
12 v, 40 amp Alternator, Regulated
Electronic Governor
Pressurized Oil System with Filter
Pressurized Cooling System
Triple Row Radiator

Engine

Diesel: Daihatsu Liquid Cooled 3 Cylinder, Cast Iron Block
Displacement: 697cc/23.6 HP
12 v Electric Starter Motor
12 v, 40 amp Alternator, Regulated
Electronic Governor
Pressurized Oil System with Filter
Pressurized Cooling System
Triple Row Radiator

Air Compressor: Thomas Clutch Driven

Vacuum Blower: Proprietary Tuthill, 4005 Dominator Tri Lobe

Solution System: Dual High Pressure Tank compressed air fed

Heating System: 1 Stainless Steel Coil Blower Exhaust Heat Exchanger
1 Stainless Steel Coil Coolant Heat Exchanger

Drive System: Proprietary Engine to Blower Drive Bell Housing (Patent Pending)

Instruments and Controls: Solution Temperature Gauge, 0-250°F
Engine Coolant Temperature Gauge, 0-250°F
Vacuum Level Gauge, 0-30" Hg
Hour Meter, Machine Run Time
Overheat Shutdown Lamp
Overheat Engine Lamp
Glow Plug Lamp (Diesel Only)
Engine Oil Pressure Lamp
Pump Out Operating Lamp
Vacuum Tank Full Lamp
Keyed Ignition
Circuit Breakers Panel
Electronic Three Speed Engine Throttle
Recovery Tank Drain Valve
Manual Engine Choke

Instruments and Controls (Cont.): Blower Lubrication Port
Auto Pump Out Switch

Recovery Tank: 50 gallon Aluminum, Epoxy Finish (Optional)
100 gallon Aluminum, Epoxy Finish

High Pressure Hose: 3/16" High Temperature, Lined, Vinyl Covered
Hose rated to 2200 PSI, 250° F.

Vacuum Hose: 2" Reinforced

Standard Equipment: Machine Power Console
Full Instrumentation
Thomas Clutch Driven Air Compressor
Tuthill Dominator Tri-Lobe™ Vacuum Blower
Stainless Steel Water Heating Package
Vacuum Recovery Tank
2 Five Gallon Stainless Steel Solution Tanks with holder
1 2 ½ Gallon Stainless Steel Air Tank
150 ft, 2" Vacuum Hose
150 ft, 3/16" Solution Line
10 ft, 1½" Recovery Drain Line
Battery Box
Van Installation Kit
Operation Manual

Machine Layout (Gas)

Recovery Tank – Holding tank for solution recovered from the carpet

Engine Mode Switch – Controls the speeds of the engine.

Choke – Pull style cable for cold starts.

Compressor Valve – Allow compressed air to be purged from the system

Solution Valve – Allows priming of the high temperature solution to be purged from the system.

Solution Outlet – Hook up for the 3/16" solution hose

Lube Port – Allows the blower to be lubricated.

Vac. Hose Hook Up – Hook up for the 2" vacuum hose.

Dump Valve – Allows the recovery tank to be dumped manually into a treated sanitary system (i.e. toilet).

Ignition Switch – Main power control to the machine.

Gauges – Instruments that display engine temp, solution temp (older versions), and vacuum.

Shutdown Lights – Shows what safety switch has activated.

Pump Out Switch – Electrical switch to activate Automatic Pump Out.

Exhaust Out – Engine and Blower exhaust outlet.

Auto-Pump Out Outlet – Hook up for the pump out garden hose.

Compressor Switch – Manual control for compressor.

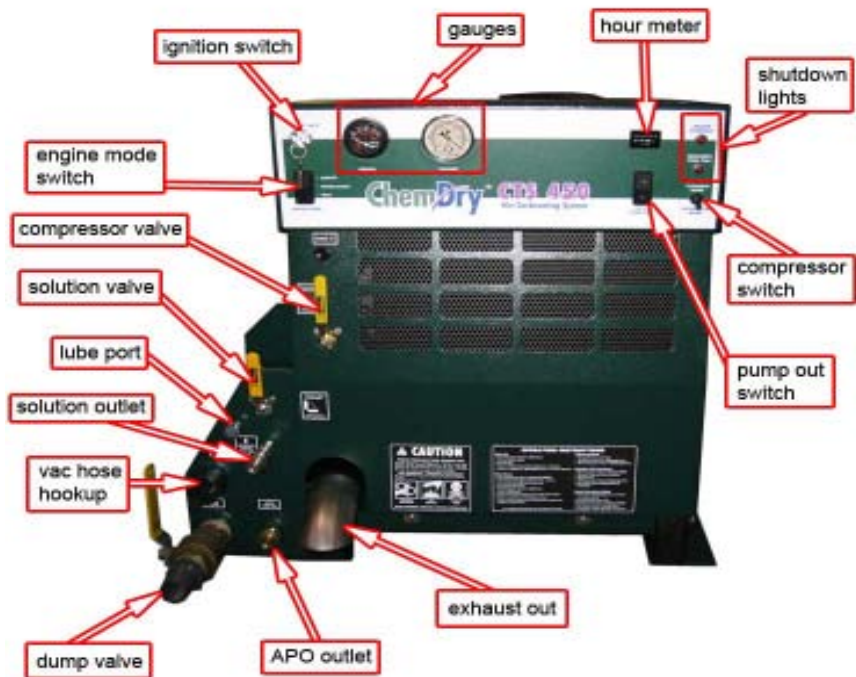

Machine Layout (Diesel)

Engine Mode Switch –

Controls the speeds of the engine.

Hour Meter – Keeps track of machine usage.

Water Separator – Removes moisture from the fuel.

Glow Plug Light – Indicates that the are pre-heating the combustion chamber.

Compressor Valve – Allow compressed air to be purged from the system

Solution Valve – Allows priming of the high temperature solution to be purged from the system.

Solution Outlet – Hook up for the 3/16" solution hose

Lube Port – Allows the blower to be lubricated.

Vac. Hose Hook Up – Hook up for the 2" vacuum hose.

Dump Valve – Allows the recovery tank to be dumped manually into a treated sanitary system (i.e. Toilet).

Ignition Switch – Main power control to the machine.

Gauges – Instruments that display engine temp, solution temp (older versions), and vacuum.

Shutdown Lights – Shows what safety switch has activated.

Pump Out Switch – Electrical switch to activate Automatic Pump Out.

Exhaust Out – Engine and Blower exhaust outlet.

Auto-Pump Out Outlet – Hook up for the pump out garden hose.

Compressor Switch - Manual control for compressor.

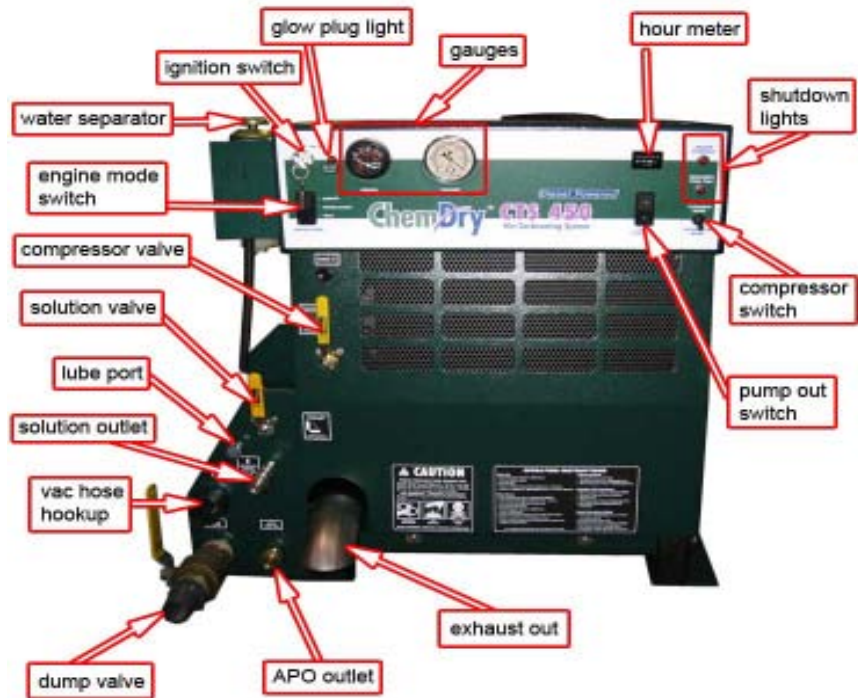

Component Descriptions

The engine produces the power required to operate the vacuum pump and air compressor.

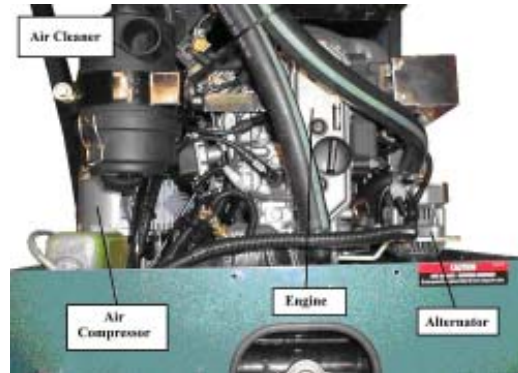

Figure 2-3

The vacuum pump is driven through the drive bell housing by the engine.

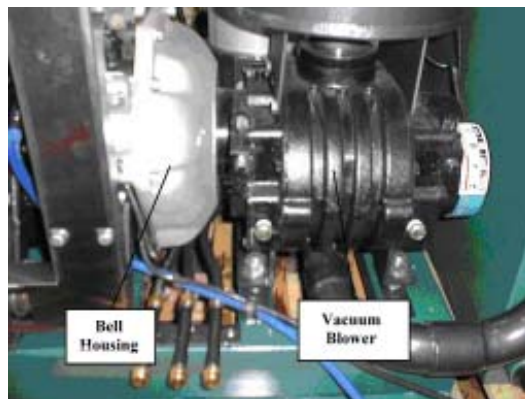

Figure 2-4

The air compressor is driven by a v-belt located at the front of the engine.



Figure 2-5

The engine, vacuum pump, air compressor, drive system, and heat exchangers are the primary components of the cleaning system. The objective of this system is to move cleaning solution from the solution tanks to the surface in need of cleaning, and eventually back to the recovery tank. The first part of this process is to move the cleaning solution out of the solution tanks. This is accomplished by pressurizing the solution tank with the air compressor. The compressed air pushes the solution out of the tanks and through hoses to the outlet manifold.

The orifice regulates the flow of the cleaning solution. The solution then flows through the heat exchange system, and into the outlet manifold. The outlet manifold contains a solution valve, pop off valve, and solution outlet. If the wand trigger is in use and the solution is at the desired temperature, the chemical solution will flow through the solution outlet. The solution valve and the pop off valve send the solution to the recovery tank.

The heat exchange system elevates the cleaning solution to the desired temperature. This system is comprised of two main components. The first component is the engine coolant heat exchanger, and the second is the blower exhaust heat exchanger. The engine coolant heat exchanger has two primary parts. These parts are the stainless steel coil that the cleaning solution flows through and the outer shell that contains the engine coolant. The blower exhaust heat exchanger is the same as the coolant heat exchanger with the exception of the outer shell that contains the exhaust from the blower.

The heating process begins when the engine coolant flows through the outer shell of the engine coolant heat exchanger. The cleaning solution is preheated as it flows through the inner coil of the engine coolant heat exchanger. The solution then flows into the blower heat exchanger coil, which is heated by the blower exhaust. Once the cleaning solution has passed through the heat exchangers the flow is directed to the outlet manifold then to the cleaning tool.

Compressor Valve

The purpose of this valve is to manually relieve the system of compressed air. This is done in situations such as removing the lids on the solution tanks.

Solution Valve

The purpose this valve is to relieve the system of excessive pressure on the solution side. This is done in situations such as “Flood Damage Mode” or in a case of the machine running for an extended period of time with no solution hoses hooked up. The pressure build up in the heat exchangers and hoses can be too high for the solution hose to be hooked up. By turning this valve to prime, it will relieve the pressure and allow the solution hose to be connected. The valve can also be used for priming the solution.

Compressor System

The compressor pump in this machine is also referred to as an oil-less reciprocating piston pump. The performance and life of this unit is greatly dependent on the care and proper maintenance it receives.

The compressor is belt and clutch driven. The clutch is controlled by the pressure switch located on the front panel. The compressor operates as follows:

- With the cleaning mode switch in “Cleaning Mode” and the pressure in the solution tank is below the set point, the pressure switch will activate the clutch. This allows the compressor to turn and pressurize the system.
- With the cleaning mode switch in “Cleaning Mode” and the pressure in the solution tank is above the set point, the pressure switch will deactivate the clutch. This will turn off the compressor.
- With the cleaning mode switch in “Extraction Mode” the clutch will turn off regardless of the pressure in the solution tank.



Figure 2-6

⚠ CAUTION

The compressor should be well ventilated. Objects placed or installed adjacent to the pump will significantly reduce the life of the pump

Filtration: Periodically check the inlet air filter. To clean filter, disassemble filter housing and use compressed air to blow dirt particles from the filter element. Replace filter when element can no longer be cleaned with this method

⚠ CAUTION

Do not operate without an inlet air filter. Excessive dirt, foreign particles, moisture, or liquids entering the pump can contribute to poor performance and/or premature failure. Dirty filters reduce pump performance by restricting air flow.

Lubrication: The CTS 450 compressor is a dry, oil-less compressor. The product uses sealed grease packed bearings and does not require additional lubrication

⚠ CAUTION

DO NOT LUBRICATE. Adding grease products to this unit will reduce performance and can potentially damage the product.

Operating Instructions

WARNING

Do not jump start machine! Damage may occur to Electrical System!

Start Up, Gasoline Engine

1. Perform daily and periodic maintenance as specified in this Owner's Manual.
2. Pull out Choke knob.
3. Switch engine speed to IDLE position.
4. Start engine.
5. Push in Choke knob.
6. Allow engine to warm up in the idle position for 3-5 minutes.
7. Switch engine speed to CARPET or UPHOLSTERY.

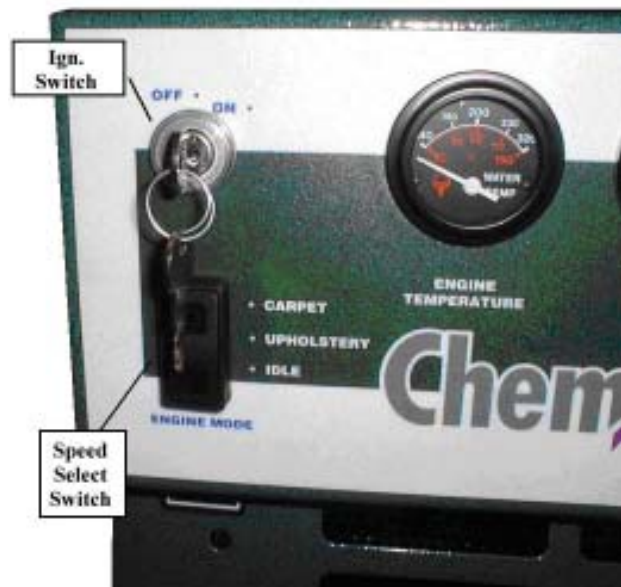

Figure 3-1

Start Up, Diesel Engine

1. Perform daily and periodic maintenance as specified in this Owner's Manual.
2. Switch engine speed to IDLE position.
3. Turn the ignition switch to the "ON" position. Wait for the "Glow Plug Light" to turn off.
4. Start engine.
5. Allow engine to warm up in the idle position for 3-5 minutes.
6. Switch engine speed to CARPET or UPHOLSTERY.

Notes:

- The engine throttle has three settings: IDLE, UPHOLSTERY, and CARPET.

WARNING

The machine cannot be run in the IDLE position for cleaning upholstery, carpet, or flood extraction. This will void the warranty.

- The machine operates at a pressure of 100-120 psi.

Carpet or Upholstery Cleaning

1. Fill solution tanks with A and B solution.
2. Position the Compressor Valve to CLEANING MODE.
3. Position the Solution Valve to CLEANING MODE.
4. Position cleaning mode switch to carpet mode.
5. Connect the solution and vacuum hoses to the tool.
6. Commence cleaning.

Notes:

- *If the Solution Valve is left in the PRIME position, the solution will evacuate from the chemical tanks into the recovery tank.*
- *If the solution tanks run dry, air will fill the system. After the solution tanks have been filled, with solution, purging the air from the system may require several minutes. This can be expedited by turning the solution valve to prime for 15 seconds, then returning the valve to cleaning mode.*

Flood Extraction

1. Position Solution Valve to PRIME mode.
2. Position Compressor Valve to PRESSURE RELIEF.
3. Set the cleaning mode switch to EXTRACTION MODE.
4. Connect vacuum hoses and tool.
5. If equipped, switch Auto Pump Out to ON.
6. Disconnect out-going quick connects on chemical tanks.



Figure 3-2

Notes:

- *The Compressor Valve must be positioned in the PRESSURE RELIEF and CLEANING MODE switch must be in EXTRACTION MODE during flood extraction. If the valve is left in the CLEANING MODE, this may cause damage to the air compressor and related components.*
- *The Solution Valve must be positioned in the PRIME mode during flood extraction. If the valve is left in the CLEANING MODE, the system may build up excessive pressure, which could cause damage to the machine.*

Solution Fill Procedure

1. Position Compressor Valve to PRESSURE RELIEF.
2. Remove the lid from the solution tank.
3. Disconnect hoses if necessary.
4. Fill solution tank with solution.
5. Replace the lid on the chemical tank.
6. Reconnect hoses if necessary.
7. Position the Compressor Valve to CLEANING MODE.



Figure 3-3

Shut Down

1. Set Compressor Valve to PRESSURE RELIEF.
2. Position cleaning mode switch to EXTRACTION MODE.
3. Lube vacuum blower at blower port. (End of Day)
4. If in use, switch OFF Auto Pump –Out.
5. Disconnect all hoses.
6. Switch engine speed to IDLE mode.
7. Switch OFF ignition.
8. Drain and Flush recovery tank with clean water.
9. Remove and clean filter bag. (End of Day)

Safety Shut Down

This machine is equipped with two safety shutdowns. This will alert you by shutting down the machine and activating one of the lights (**Figure 3-4**).

The two machine shutdowns are:

- **Engine Overheat** – This will activate when the engine coolant temperature reaches 245° F.
- **Recovery Tank Full** – This will activate once the recovery tank has reached its full capacity.



Figure 3-4

General Operating Information

1. In accordance with state and local EPA laws, do not dispose of wastewater into gutters, storm drains, streams, reservoirs, etc. Dispose wastewater into a treated sanitary system.
2. Perform daily maintenance as prescribed in this manual.

Machine Maintenance

Engine

Quick Reference List

- Check air filter
- Drain oil.
- Change oil filter.
- Fill oil.
- Remove and replace spark plugs. (Gasoline Engine Only)
- Set spark plug gap. (Gasoline Engine Only)
- Check coolant overflow bottle.
- Check radiator coolant level.
- Change fuel filter
- Visually check alternator belt.
- Visually check compressor belt.
- Tighten belts.
- Loosen belts.
- Check exhaust system (doughnut gaskets).

Engine Air Filter

- 1 Unlock the two clamps and remove cover (**Figure 4-1**).
- 2 Remove air filter cartridge.
- 3 Carefully clean out cartridge.
- 4 Reinstall air filter cartridge.
- 5 Install cover and lock clamps.

Note: Do not use pressurized air or solvents to clean cartridge.



Figure 4-1

Engine Oil and Filter Change

1. Remove oil drain cap located on right center bottom side of machine (**Figure 4-2**). Do not reinstall cap until you begin filling the engine with oil (refer to step 4).

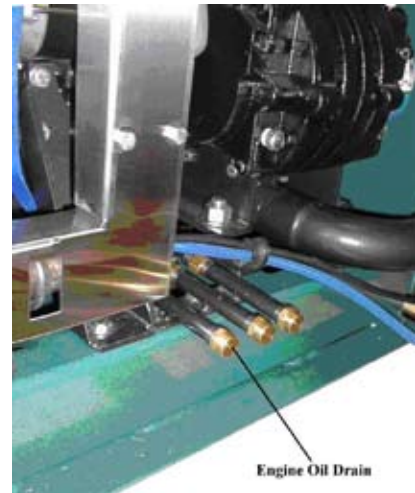

Figure 4-2

- 2 Remove oil filter located on the left side of the engine.
- 3 Apply oil to the new oil filter gasket. Install oil filter.
- 4 Remove the oil fill cap located on top of the valve cover.
- 5 Begin filling engine with 30W. After the oil begins to flow out of the oil drain fitting, re-install the cap. This will allow air to evacuate from the system and give accurate oil level readings.



Figure 4-3

! CAUTION

Failure to do this step will result in an insufficient amount of oil in the engine! Engine oil capacity is 3.5 quarts.

- 6 Check oil dipstick for proper level.
- 7 Re-install the oil fill cap.

Tools

- 11/16 inch wrench,
- Oil filter wrench

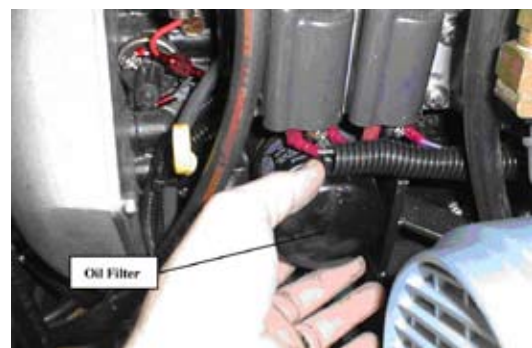

Figure 4-4

Engine Coolant

- 1 **Daily**, check the coolant overflow jug for the proper amount of coolant. The fluid level should reach the top line. (**Figure 4-5**)
- 2 **Weekly**, remove the radiator cap and check the coolant for proper level (**Figure 4-6**). This level should be approximately ½ inch from the top.
- 3 When adding coolant to the system, use a mixture of 50% antifreeze and 50% distilled water.



Figure 4-5



Figure 4-6

Spark Plug Replacement (Gas Engine Only)

The spark plugs are located at the center of the left side of the engine.

1. Unplug the wires from the spark plugs (**Figure 4-7**).
2. Remove the spark plugs with a 5/8" Socket.
3. Install the new plugs with a gap of 0.030".
Champion Part # RC12YC
HRI Part # 000-106-016
4. Re-install the spark plug wires.

Tools

- 5/8 inch spark plug socket,
- 0.030" feeler gauge



Figure 4-7

Fuel Filter (Gas Engine Only)

The fuel filter is located underneath the van. It is between the fuel filler neck and the fuel through floor assembly.

1. Loosen the hose clamps on either side of the filter.
2. Pull the hoses off of the filter.
3. Install the new filter (**Figure 4-8**). The filter has an arrow on it. The arrow should point towards the floor of the van.
HRI Part # 049-049
4. Tighten the hose clamps.



Figure 4-8

Tools

- ¼ inch nut driver

Fuel Separator (Diesel Engine)

Water should be drained from the fuel separator **weekly**. The fuel filter should be replaced every **800 hours**. See **Figure 4-9** for reference.

To drain water:

1. Stop engine
2. Place a drain pan under fuel filter and loosen the drain plug approximately 1 turn.
3. Water should drain. If necessary, operate priming pump to drain water, but only until fuel flows from filter.
4. Tighten drain plug. Bleed air from fuel line.
5. Start engine and check for leaks.

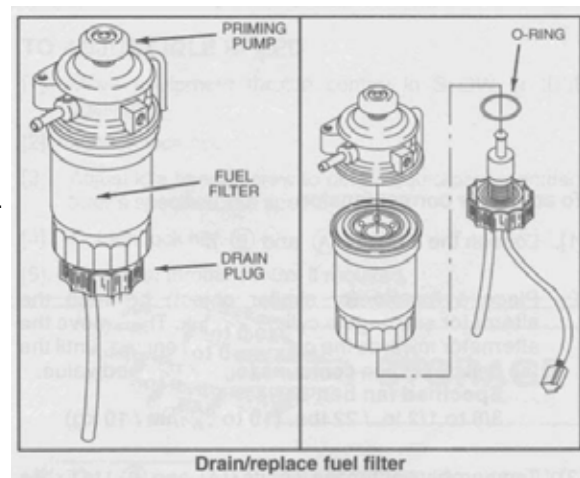

Figure 4-9

To replace fuel filter:

1. Remove drain plug and discard O-Ring.
2. Remove fuel filter with filter wrench.
3. Screw new filter on by hand until gasket contacts housing. Then tighten 1/3 turn more.
4. Install drain plug with new O-Ring.
5. Bleed air from fuel line. Start engine and check for leaks.

Blower

Quick Reference List

- Check blower level.
- Drain oil.
- Fill oil.
- Lube blower.

Blower Oil Change

The vacuum blower has two sight glasses for checking the oil level. One is located in the rear of the blower (**Figure 4-10**) and the other is towards the front near the bell housing. The oil level should be checked daily to ensure that it reaches over half the sight glass.

1. Remove the two oil drain caps, which are located on right center bottom side of the machine.
2. Remove oil fill caps.
3. Fill the blower with 40W non-detergent oil. After oil begins to flow out of the oil drain fitting, re-install the caps. This will allow air to evacuate from the system and give accurate oil level reading.

WARNING

Failure to do this step will result in an insufficient amount of oil in the blower will lead to damage or failure!

4. Re-install the oil fill plugs.

Tools

- 11/16 wrench

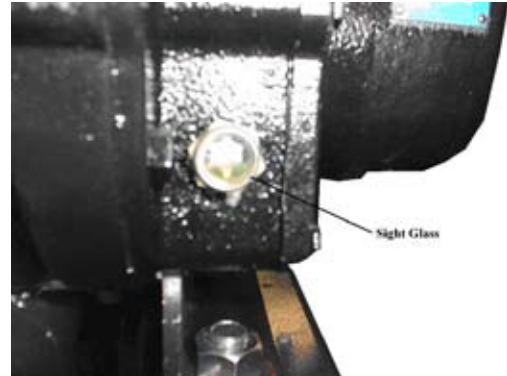

Figure 4-10

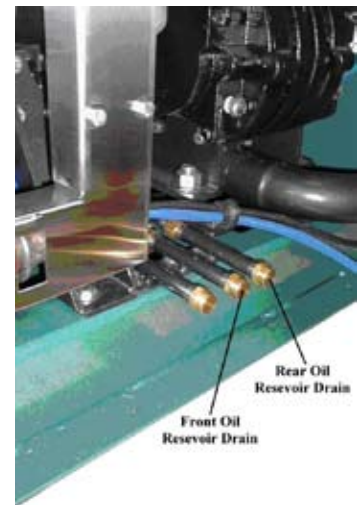

Figure 4-11



Figure 4-12

Recovery Tank

Quick Reference List

- Remove and Clean Filter Basket
- Remove and Clean Rectangular Blower Filter
- Clean Vac Relief Assembly

1. Remove the filter basket and clean. **Perform this operation after every cleaning job.**
2. Clean the rectangular blower filter of debris **daily**. This filter is connected to the vacuum blower. Failure to clean the filter daily will result in a loss of vacuum. This loss of vacuum will cause the blower to over heat.
3. Rinse out the recovery tank thoroughly. **Perform this operation daily.**
4. Clean vacuum relief assembly as necessary.
5. Replace all parts before starting up machine.

This page intentionally left blank.

Solution System

Quick Reference List

- Remove filters.
- Clean filters.
- Remove orifice.
- Clean orifice.
- Inspect manifold.
- Rinse tanks.

Orifice Manifold

The orifice assembly is located on the side of the solution tank bracket, in line with the outlet hose. The purpose of the orifice is to control the amount of solution being used and to filter any debris from entering the system.

Orifice and Filter Maintenance

1. Position Compressor Valve to PRESSURE RELIEF.
2. Remove the filter (Stainless Steel plugs) and orifices by disconnecting the stainless steel quick connect (**Figure 4-13**).
3. Clean the filter and orifice with fresh water or compressed air (**Figures 4-14 and 4-15**). **Perform this operation daily.**

Tools

- 3/32 Allen wrench



Figure 4-13



Figure 4-14

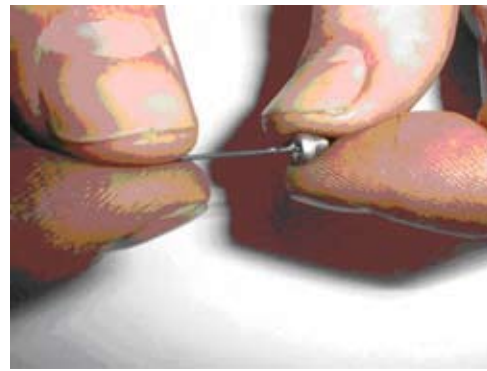

Figure 4-15

General Maintenance

1. Inspect hoses.
2. Inspect wire connections.
3. Check nuts, belts, and hose clamps.

Freeze Guard Information

Your machine should be protected from freezing for any temperature below 35° F.



WARNING

Water freezes at 32° F

Freeze Guard Procedure

1. Empty the solution tank. Once it has been emptied, reinstall the lid and all the hoses.
2. Turn the Solution Valve to the “Purge” position.
3. Turn the Air Valve to the “Cleaning Mode” position.
4. Position cleaning mode switch to CARPET MODE
5. Run the machine for approximately 3 to 5 minutes.
6. Empty the recovery tank.

CTS 450 Hot Carbonating Truckmount System™

**CTS 450
GENERAL MAINTENANCE LOG**

MAX HRS	DAILY SERVICE	OIL RECOMMENDATIONS						
		BLOWER						
8	ENGINE OIL check	BLOWER	40 weight non-detergent					
8	MACHINE general inspection	PUMP	30 weight non-detergent					
8	RECOVERY TANK FILTER BAG clean	ENGINE	30 weight motor oil					
8	RECOVERY TANK STAINLESS STEEL FILTER Clean							
8	BLOWER INLET spray with lubricant		NOTE: Overhead valve engines can use multi-viscosity oil, but will experience increased oil consumption.					
8	Empty Air Tank							
8	Clean ORIFICE FILTER							
8	ORIFICE inspect/clean							
	WEEKLY SERVICE	DATE & HOURS						
20	COOLANT check							
See Note	OIL change with filter		Note: Break-in period determined by manufacturer. Reference engine manual.					
25	BLOWER check oil level							
25	Drain Fuel Separator (Diesel Only)							
25	DRIVE SYSTEM tighten screws							
25	COMPRESSOR BELTS & PULLEYS check for wear <i>HRI Part # 000-010-124 Gates Belt # 9340</i>							
25	HIGH PRESSURE LINES check for chafing							
25	NUTS & BOLTS check tightness							
25	ORIFICE MANIFOLD CHECK VALVES inspect/clean							
25	Check the coolant level.							
25	VACUUM RELIEF VALVE inspect, clean, lube							
25	VACUUM TANK clean & flush							
25	WIRING check for chafing							
25	FLOAT SWITCHES check for debris							
	MONTHLY SERVICE							
100	ENGINE OIL change							
100	ENGINE AIR CLEANER clean <i>HRI Part # 000-049-071</i>							
100	BATTERY WATER LEVELS check							
200	OIL FILTER change							
200	COMPRESSOR BELT check tension							
	QUARTERLY SERVICE (3 MONTHS)							
300	FUEL LINES check for wear							
300	SPARK PLUGS clean and gap (Gas Only) <i>HRI Part # 000-106-016 Champion Part # RC12YC</i>							
300	SOLUTION TANKS clean & flush							
400	BLOWER OIL change							

CTS 450 Assemblies & Parts

Figure 5-1 Machine Assembly - Front View
D-5256 Rev D

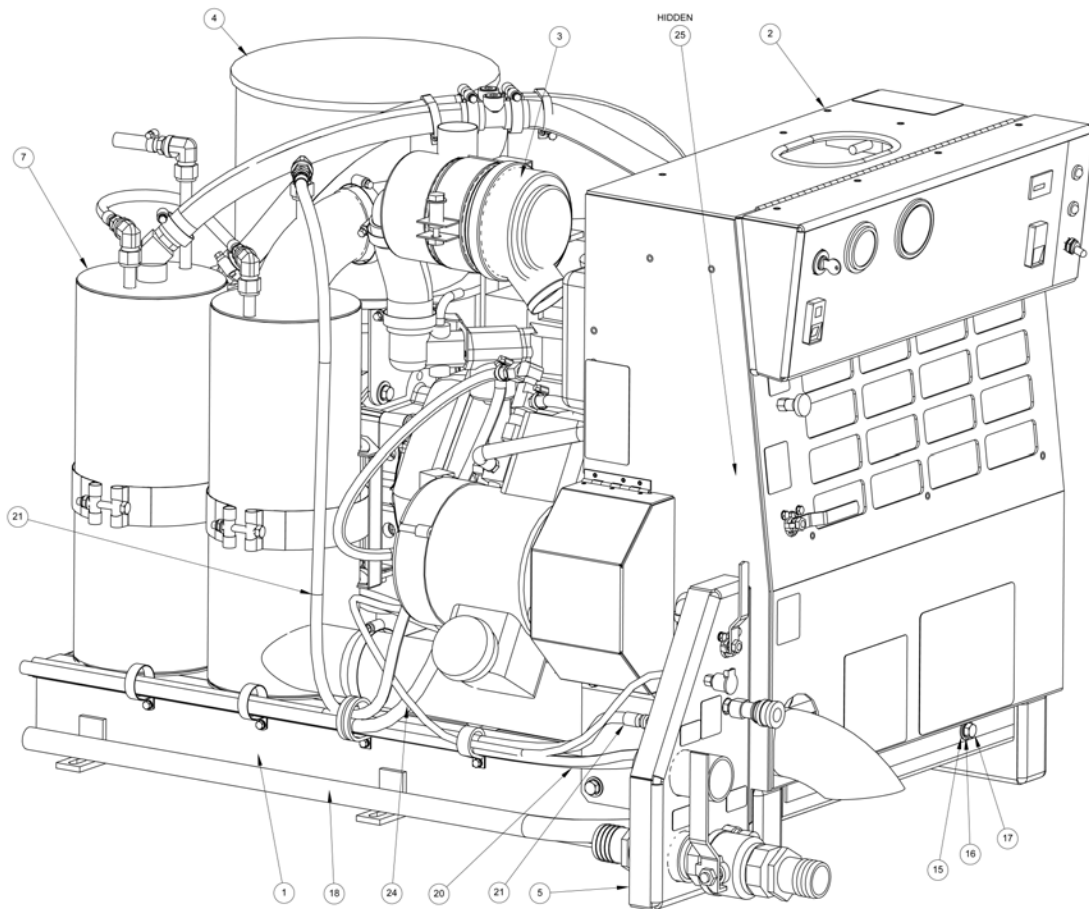

Figure 5-2 Machine Assembly - Rear View
D-5256 Rev E

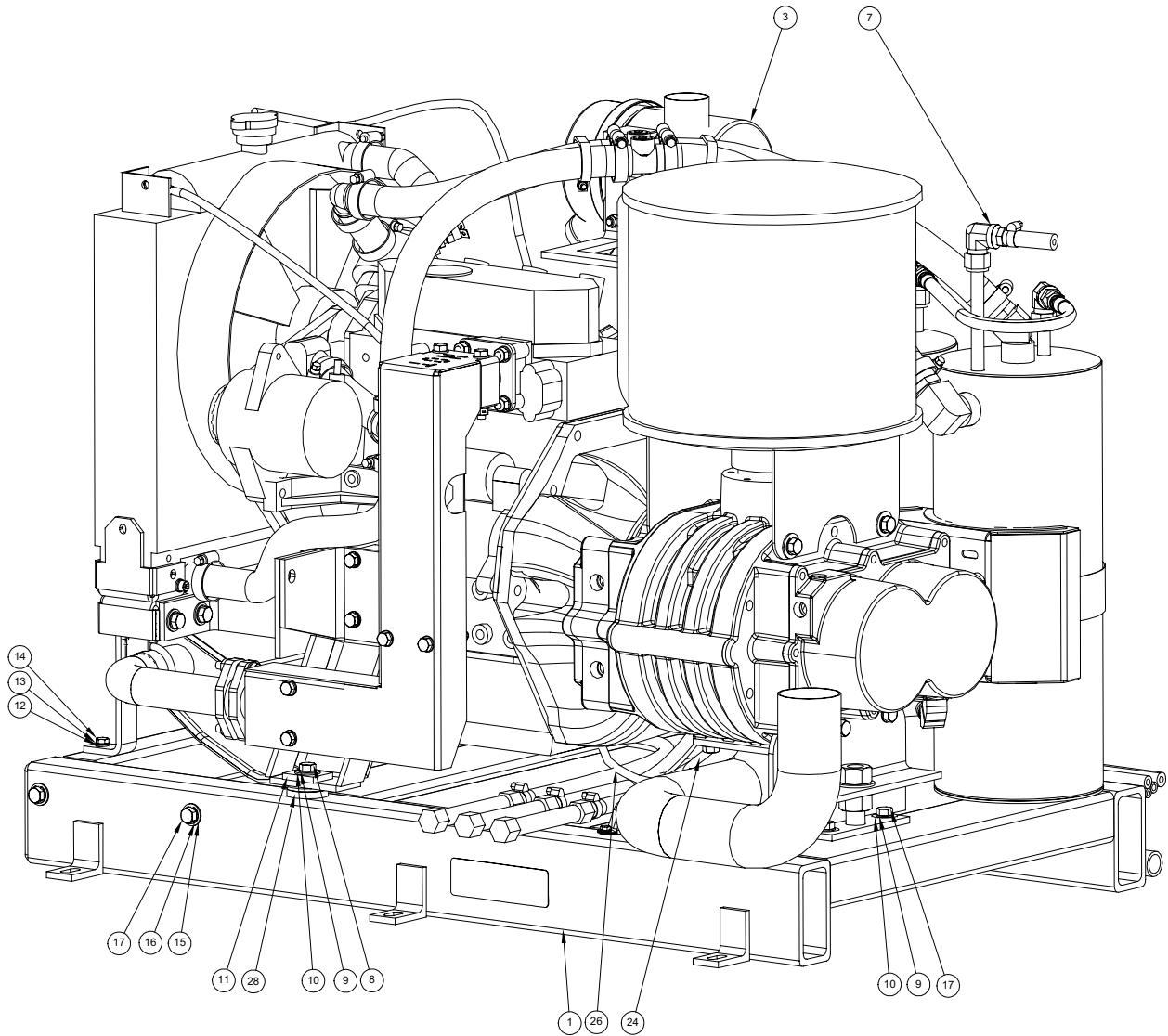
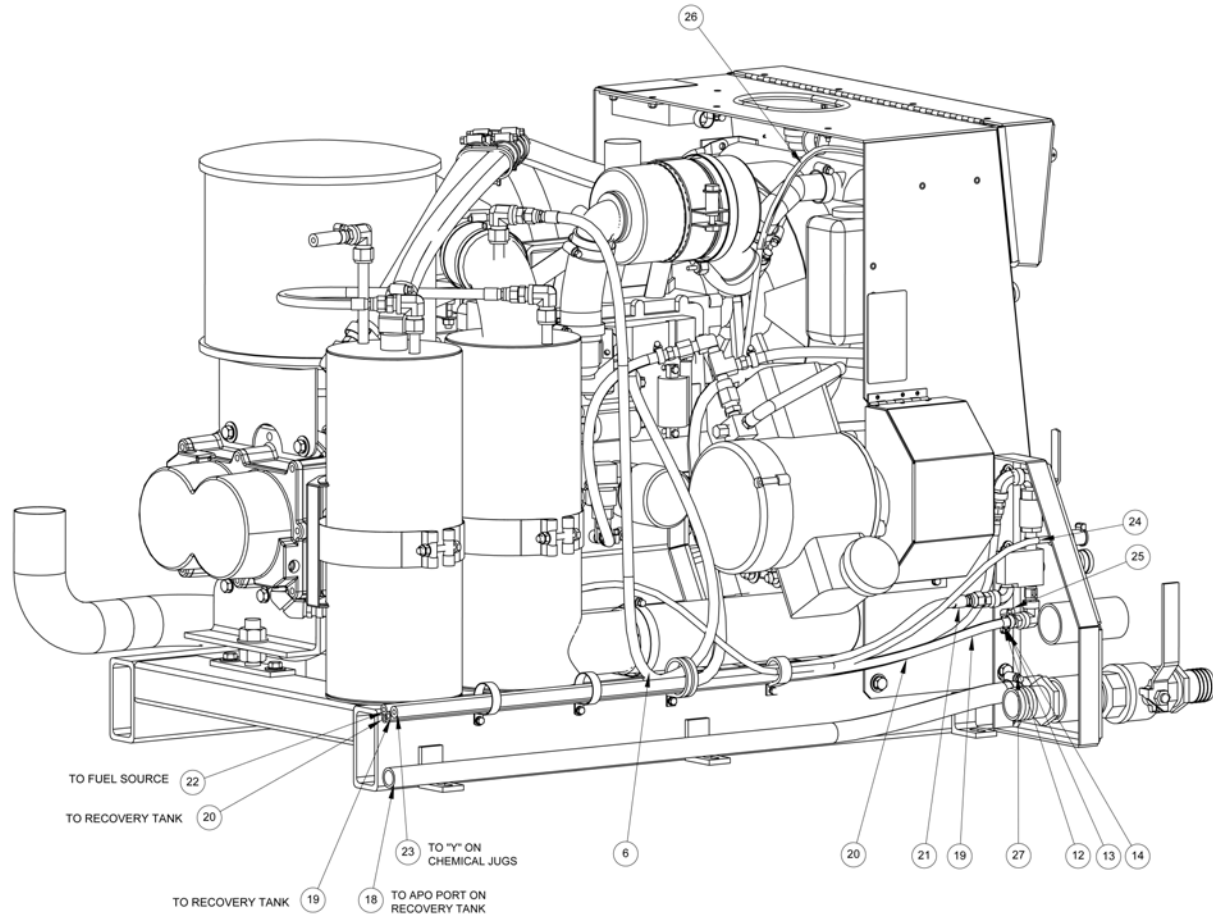

Figure 5-3 Machine Assembly - Side View
D-5256 Rev D



Machine Assembly Parts List

Item	Part Number	Description	Qty
1	610-001-029	Assembly, Frame - CTS 450 (Fig. 5-4)	1
2	610-020-029	Assembly, Dash - CTS 450 (Fig. 5-5 & 5-6)	1
3	610-003-029	Assembly, Engine - CTS 450 (Fig. 5-10 & 5-11)	1
4	610-002-029	Assembly, Blower - CTS 450 (Fig. 5-16)	1
5	610-019-029	Assembly, Dump & Vacuum Bracket (Fig. 5-17 & 5-18)	1
6	610-005-029	Assembly, Blower Exhaust Heat Exchanger (Fig. 5-20)	1
7	610-006-029	Assembly, Coolant Heat Exchanger (Fig. 5-19)	1
8	000-143-025	Screw, 3/8"-16UNC x 1.25" Lg. Hex Head Grd 8	2
9	000-174-021	Washer, 3/8" Lock	4
10	000-174-005	Washer, 3/8" Flat	4
11	000-174-068	Washer, Blower Feet	2
12	000-174-003	Washer, 1/4" Flat	5
13	000-174-019	Washer, 1/4" Lock	5
14	000-143-001	Screw, 1/4"-20UNC x 0.75" Lg. Hex Head	5
15	000-174-032	Washer, 3/8" Flat	6
16	000-174-057	Washer, 3/8" Lock	6
17	000-143-017	Screw, 3/8"-16UNC x 0.75" Lg. Hex Head Grd. 8	8
18	000-068-004	Hose, 3/4" I.D. Steam	1
19	000-068-015	Hose, 1/4" I.D. Bulk	1
20	000-068-723	Hose, 3/16" x 75" Lg. Teflon w/ JIC Ends	1
21	000-068-722	Hose, 3/8" x 46" Lg. Teflon w/ JIC Ends	1
22	000-068-660	Hose, 1/4" Fuel - Trident	1
23	000-068-131	Hose, 1/4" I.D. Hi-Temp Silicone	1
24	000-068-030	Hose, 5/32" I.D. Vacuum	1
25	000-033-003	Clamp, Size #4 Mini	2
26	000-068-030	Hose, 5/32" I.D. Vacuum	1
27	000-033-026	Clamp, Size #10 Hose	1
28	000-174-105	Washer, 1-1/16" I.D. Self Aligning Spherical 2 Pc Set	2

Figure 5-4 Frame Assembly
D-5258 Rev B

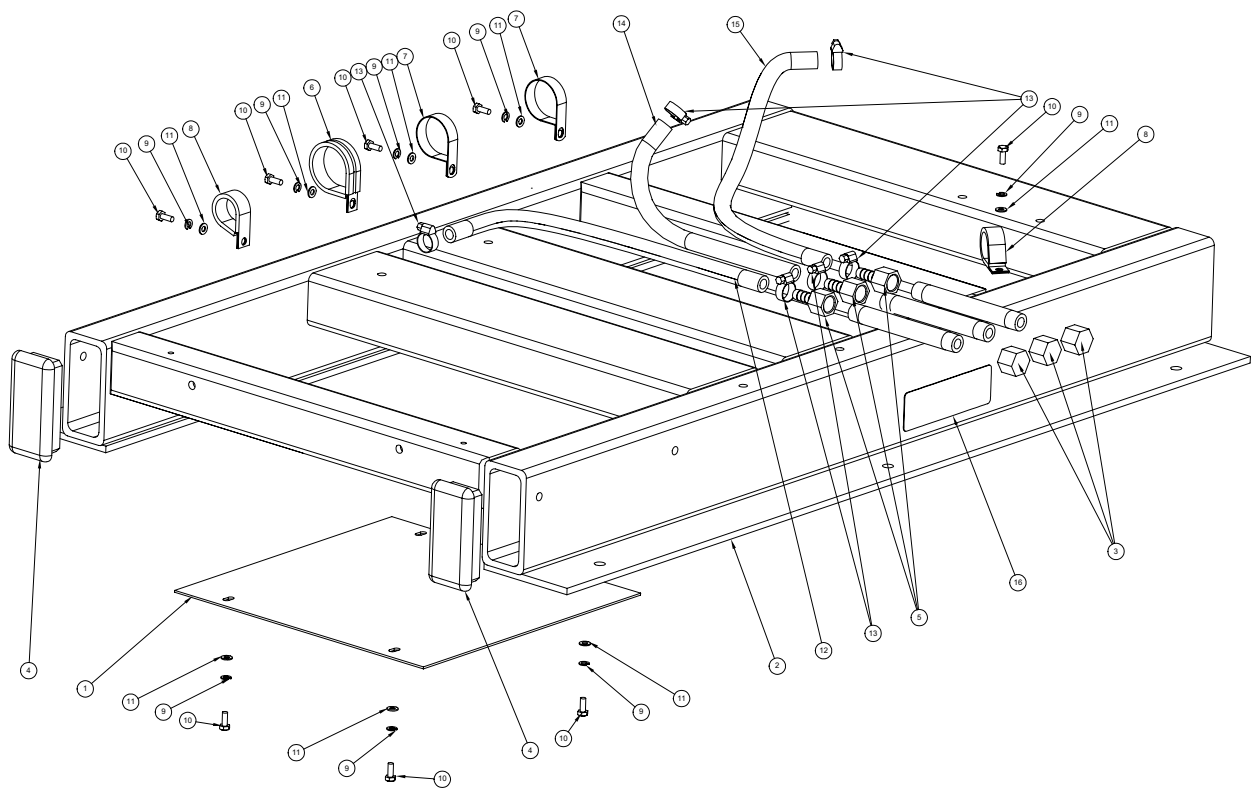

Frame Assembly Parts List

Item	Part Number	Description	Qty
1	000-108-124	Protector, Muffler Heat Shield - CTS 450	1
2	000-055-159	Frame, Weldment - CTS 450	1
3	000-027-008	Cap, 3/8" FPT	3
4	000-027-034	Cap, Frame End - Modified - Maxx/CTS 450	2
5	000-052-488	Insert, #F66 (3/8" NPT x 3/8" Hose Barb)	3
6	000-033-050	Clamp, 1-3/4" Cushion Loop	1
7	000-033-053	Clamp, 1-1/2" Cushion Loop	2
8	000-033-057	Clamp, 1" Cushion Loop	2
9	000-174-014	Washer, #10 Lock	9
10	000-143-126	Screw, #10-24UNC x 0.50" Lg. Hex Head	9
11	000-174-001	Washer, #10 Flat	9
12	000-068-085	Hose, 3/8" I.D. Hi-Temp	1
13	000-033-005	Clamp, Size #5 Hose	6
14	000-068-085	Hose, 3/8" I.D. Hi-Temp	1
15	000-068-085	Hose, 3/8" I.D. Hi-Temp	1
16	000-081-215	Label, Oil Drain Plugs - CTS 450	1

Figure 5-5 Dash Assembly - Front View
D-5257 Rev E

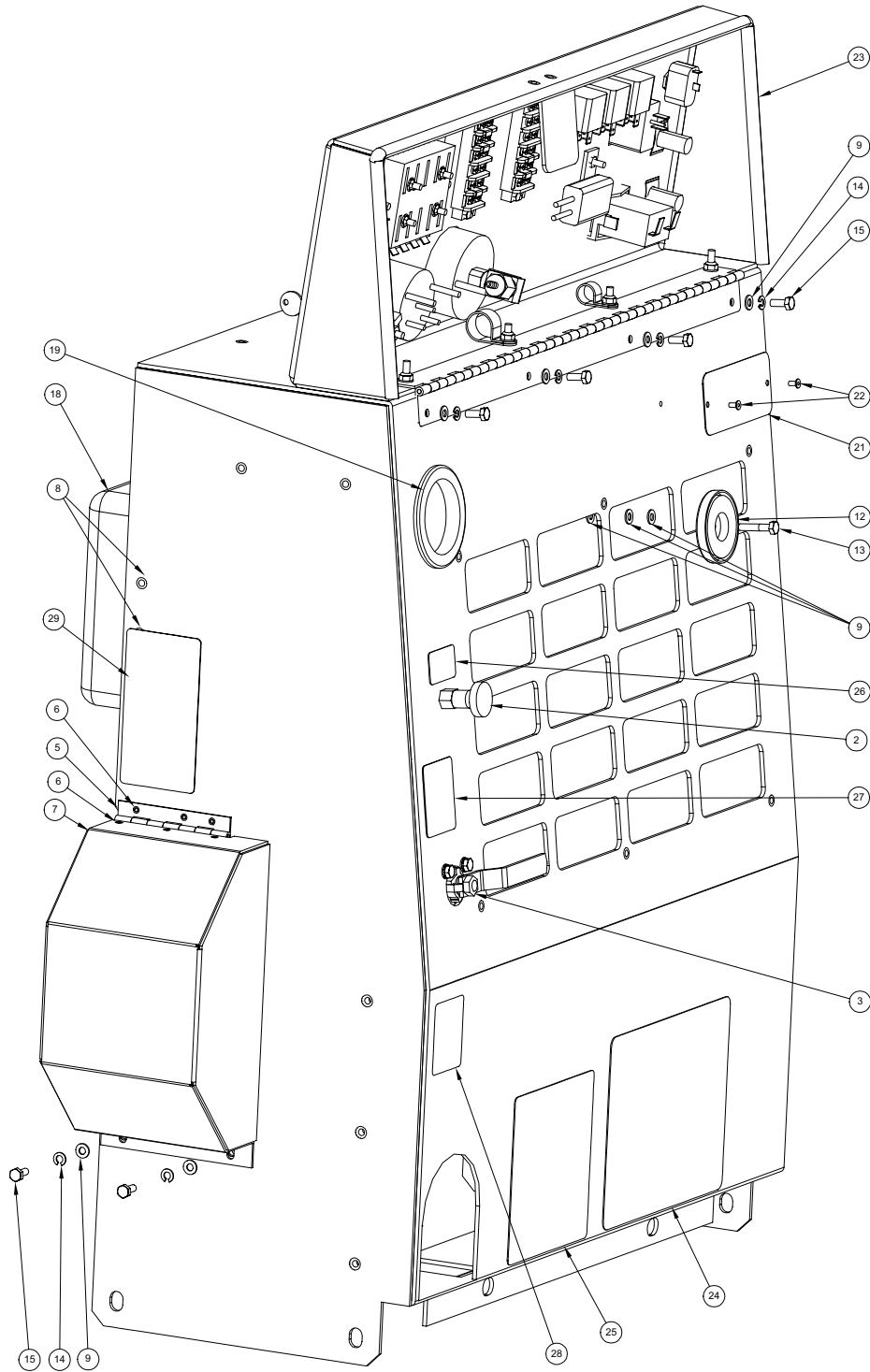

CTS 450 *Hot Carbonating Truckmount System*

Figure 5-6 Dash Assembly - Rear View
D-5257 Rev E

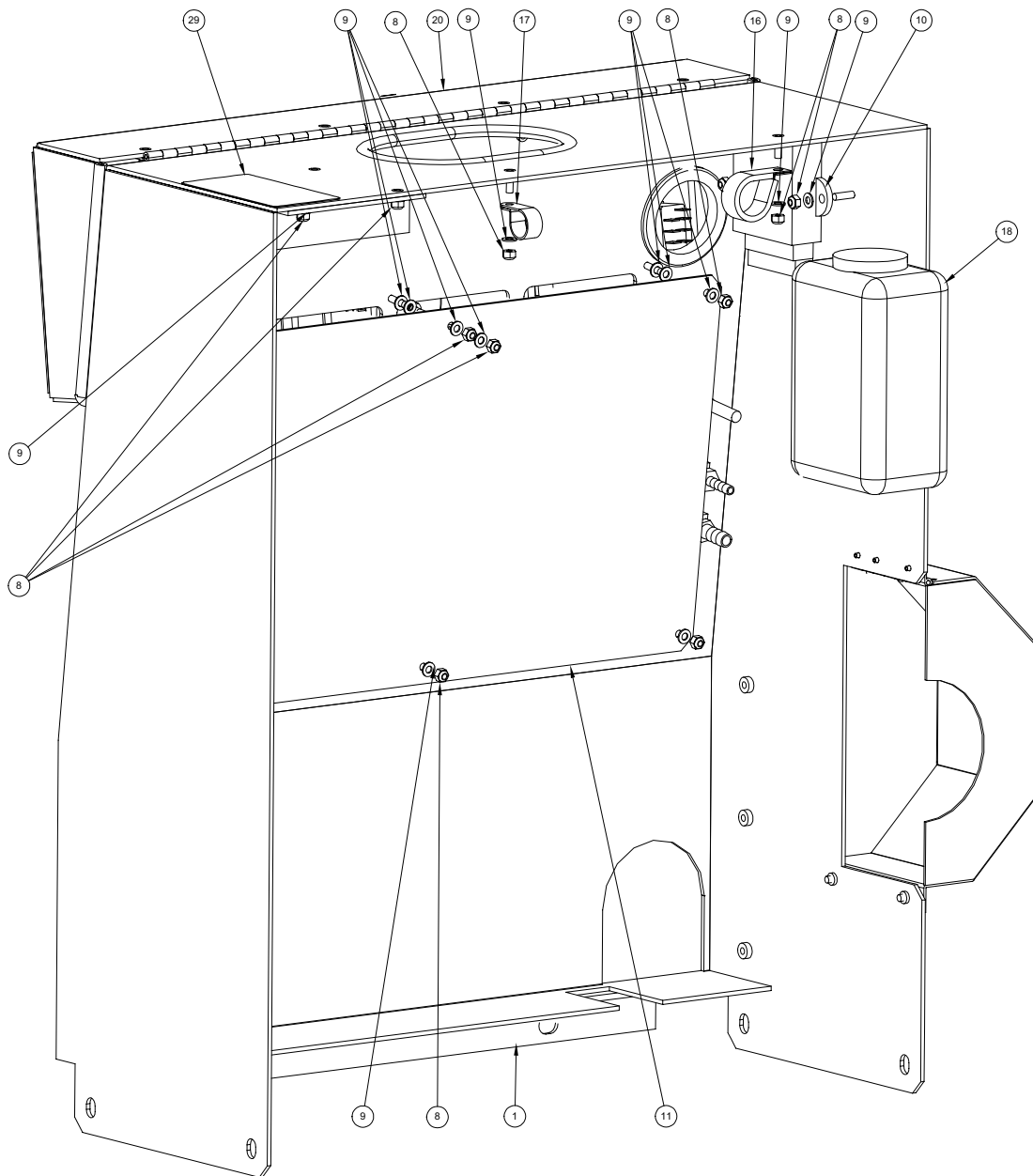

Dash Assembly Parts List

Item	Part Number	Description	Qty
1	000-100-135	Panel, Dash - Weldment - CTS 450	1
2	000-025-011	Cable, Choke (5 Foot)	1
3	610-018-029	Assembly, Compressor Regulator - CTS 450 (Fig. 5-9)	1
4	000-029-016	Governor, Hall Affects Maxx 450D/470D	1
5	000-067-034	Hinge, Compressor Cover - CTS 450	1
6	000-140-001	Rivet, 1/8" x 1/4" Aluminum	6
7	000-108-123	Protector, Compressor Pulley - Weldment - CTS 450	1
8	000-094-034	Nut, #10-24UNC Nylock	17
9	000-174-001	Washer, #10 Flat	36
10	000-072-010	Ignition Processor, 700G Daihatsu	1
11	000-100-102	Panel, Perforated Grill	1
12	000-089-003	Magnet, Treadmaster	1
13	000-143-134	Screw, #10-24UNC x 1.00" Lg Hex Head	1
14	000-174-014	Washer, #10 Lock	6
15	000-143-126	Screw, #10-24UNC x 0.50" Lg. Hex Head	6
16	000-033-057	Clamp, 1" Cushion Loop	1
17	000-033-023	Clamp, 3/4" Nylon Hose	1
18	000-047-016	Tank, Coolant Overflow - Daihatsu Engine	1
19	000-060-003	Grommet, 2.50"	1
20	000-131-131	Trimlok, 3/8" x 1/8" Edge Trim	1
21	000-105-012	Plate, Machine Serial I.D.	1
22	000-140-015	Rivet, 1/8" x 1/4" Lg. Pop	2
23	Fig. 5-7 & 5-8	Assembly, Brow - Dash - CTS 450	1
24	000-081-215	Label, Maintenance & Lubrication Schedule - CTS 450	1
25	000-081-215	Label, Engine Produces Toxic Gas - CTS 450	1
26	000-081-215	Label, Choke - CTS 450	1
27	000-081-215	Label, Compressor Valve - CTS 450	1
28	000-081-215	Label, Solution Valve - CTS 450	1
29	000-081-215	Label, Caution Rotating Equipment - CTS 450	2

CTS 450 *Hot Carbonating Truckmount System*

Figure 5-7 Brow Assembly - Front View
D-5521 Rev D

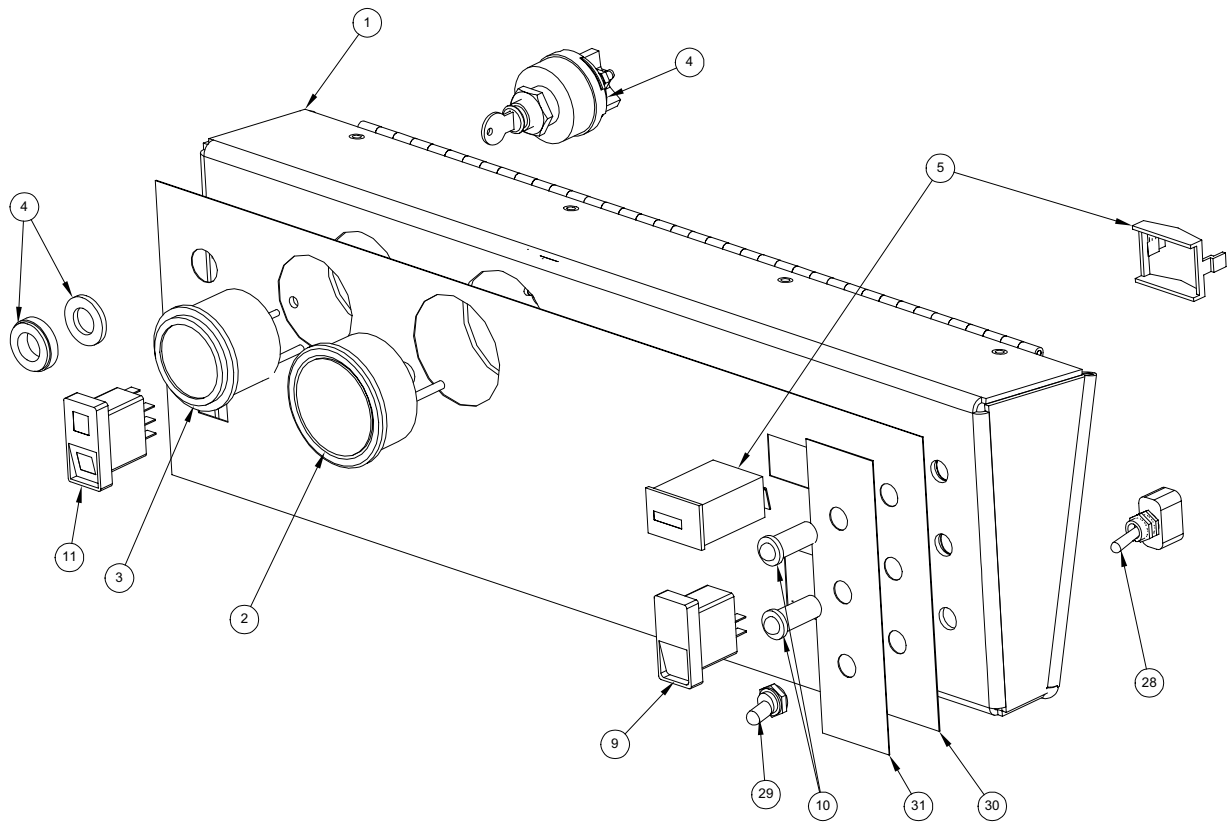
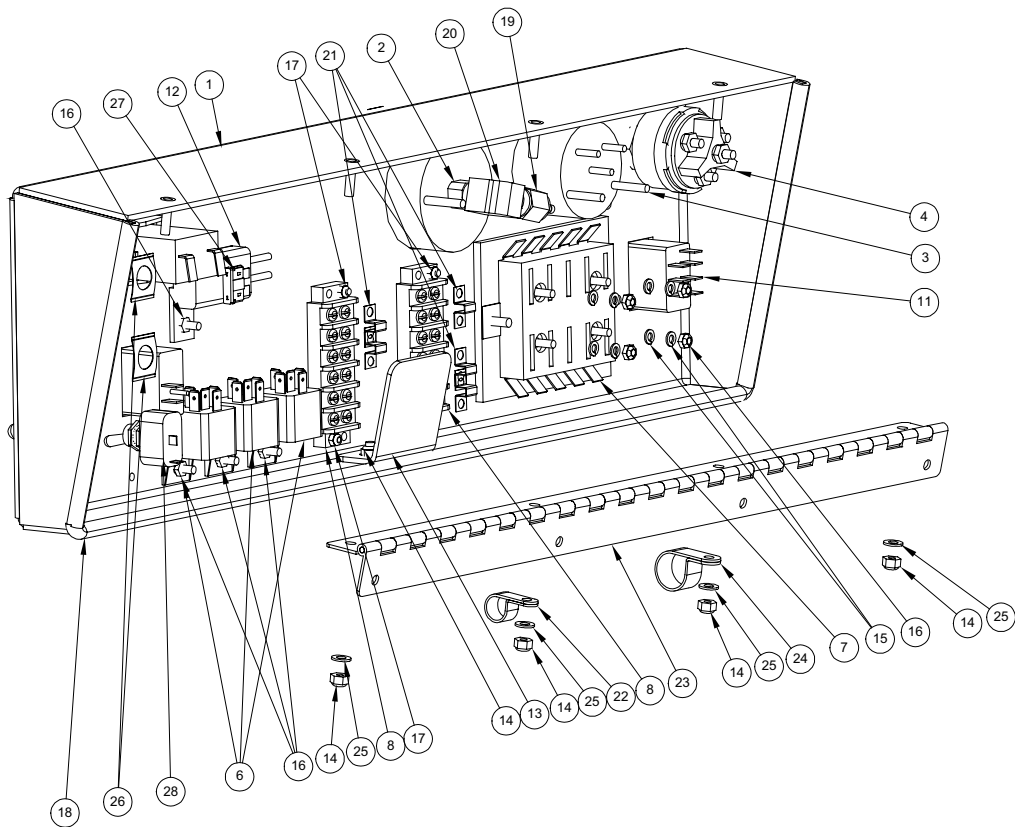

Figure 5-8 Brow Assembly - Rear View
D-5521 Rev D



Brow Assembly Parts List

Item	Part Number	Description	Qty
1	000-100-136	Panel, Dash Brow - Weldment - CTS 450	1
2	000-074-025	Gauge, 0-30"Hg Vac. 2 1/2"	1
3	000-074-024	Gauge, Temperature	1
4	000-157-008	Switch, Ignition	1
5	000-074-018	Meter, Rectangular w/o Bezel	1
6	000-157-022	Switch, Relay	3
7	000-056-030	Diode Panel	1
8	000-012-002	Block, 6 Post Terminal	2
9	000-157-040	Switch, 20 AMP Rocker	1
10	000-084-015	Lamp, 12V 2W Round Red Indicator	2
11	000-157-131	Switch, 3 Way Speed Control	1
12	000-056-006	Fuse Holder, Inline Weather Proof	1
13	000-015-839	Bracket, Magnet - Painted - CTS 450	1
14	000-094-034	Nut, #10-24UNC Nylock	6
15	000-174-025	Washer, #8 Lock	8
16	000-094-059	Nut, #8-32UNF Nylock	8
17	000-094-063	Nut, #6-32UNC Nylock	4
18	000-131-131	Trimlok, 3/8" x 1/8" Edge Trim	1
19	000-052-652	Insert, #F42 (1/4" FPT x 1/8" Barb)	1
20	000-052-085	Elbow, 1/4" NPT Street	1
21	000-037-011	Connector, "Jumper" Terminal Block	5
22	000-033-022	Clamp, 1/2" Nylon Hose	1
23	000-067-014	Hinge, Dash - CF 3.7/CTS 450	1
24	000-033-023	Clamp, 3/4" Nylon Hose	1
25	000-174-001	Washer, #10 Flat	4
26	000-033-049	Clamp, Indicator Lamp	2
27	000-056-011	Fuse, 30 AMP Plug In	1
28	000-157-101	Switch, 15 AMP 115 Volt Toggle	1
29	000-108-144	Protector, Chrome Switch	1
30	000-081-215	Label, Dash - CTS 450	1
31	000-081-239	Label, Compressor Retro Kit - Dash - CTS 450	1

Figure 5-9 Compressor Regulator Assembly
C-6249 Rev B

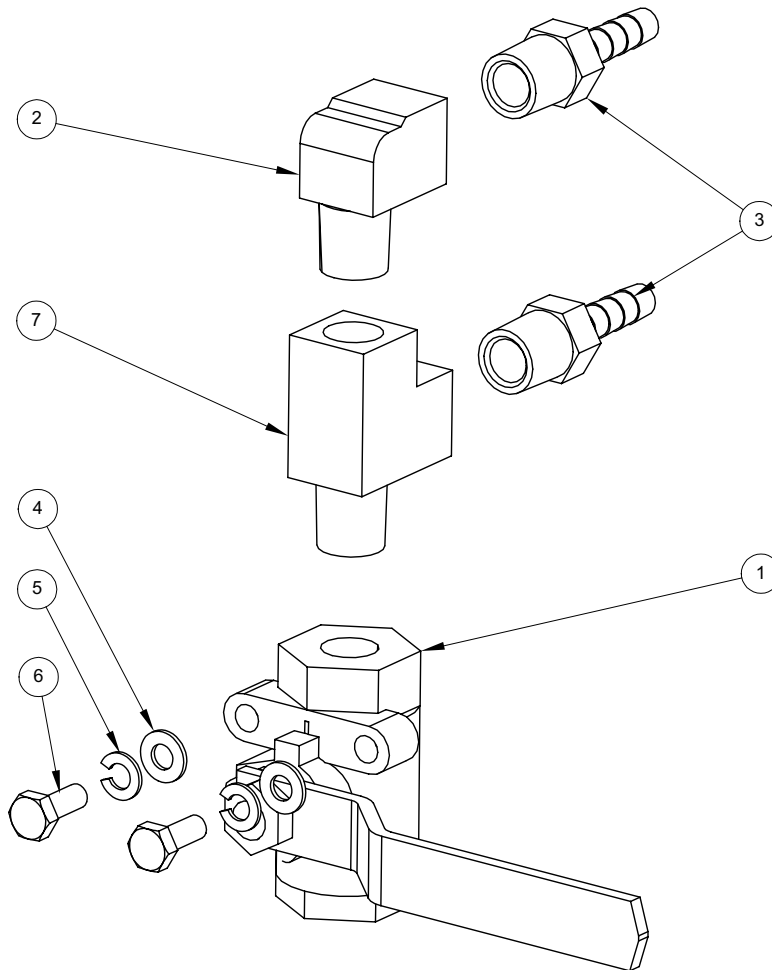

Compressor Regulator Assembly Parts List

Item	Part Number	Description	Qty
1	000-169-090	Valve, 1/4" NPT Panel Mount - Full Port Ball	1
2	000-052-085	Elbow, 1/4" NPT Street	1
3	000-052-100	Insert, #44 (1/4" NPT x 1/4" Barb)	2
4	000-174-001	Washer, #10 Flat	2
5	000-174-014	Washer, #10 Lock	2
6	000-143-126	Screw, #10-24UNC x 0.50" Lg. Hex Head	2
7	000-052-090	Tee, 1/4" NPT Branch M-F-F	1

Figure 5-10 Engine Assembly - Right View
D-5259 Rev F

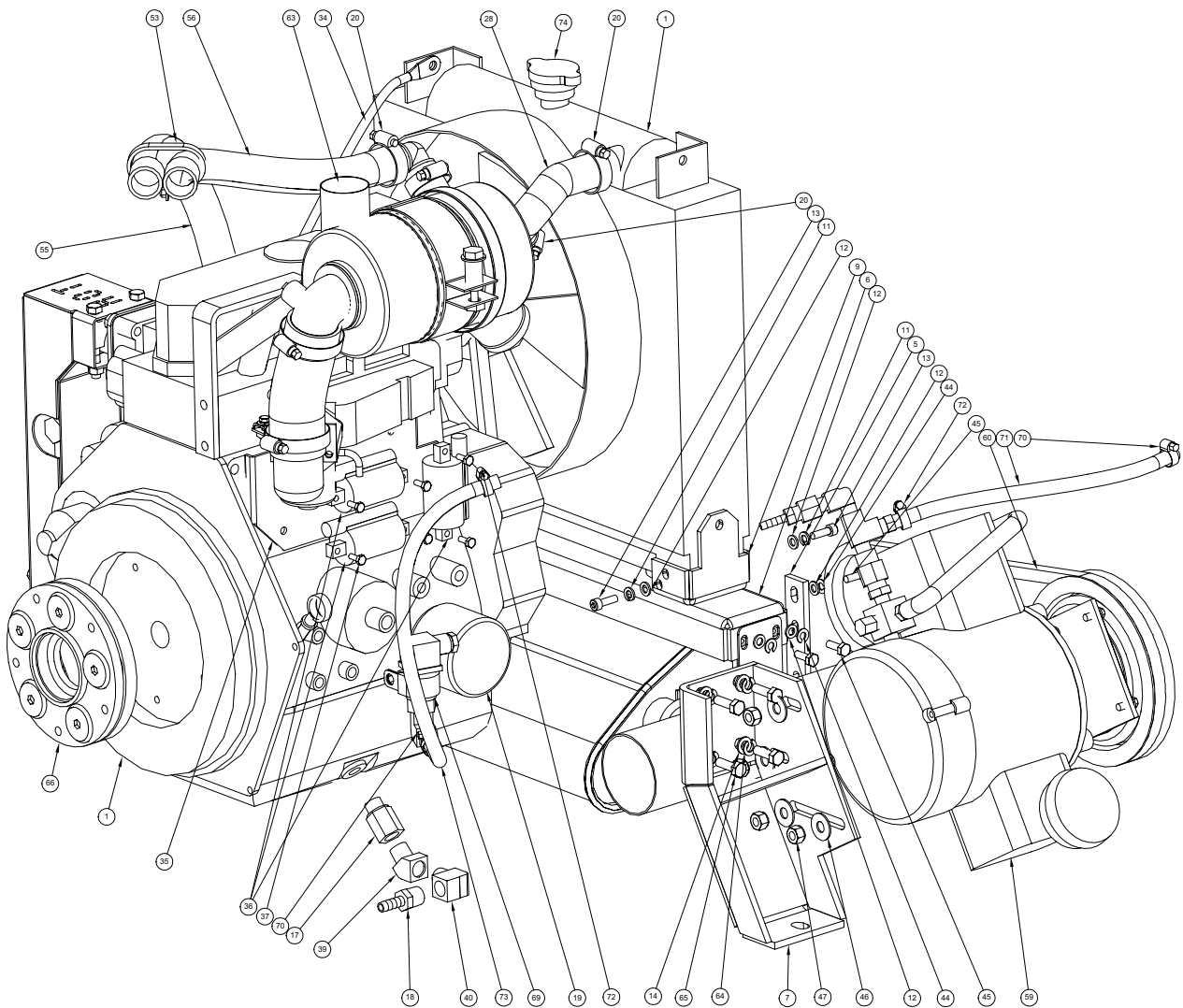

CTS 450 *Hot Carbonating Truckmount System*

Figure 5-11 Engine Assembly - Left View
D-5259 Rev F

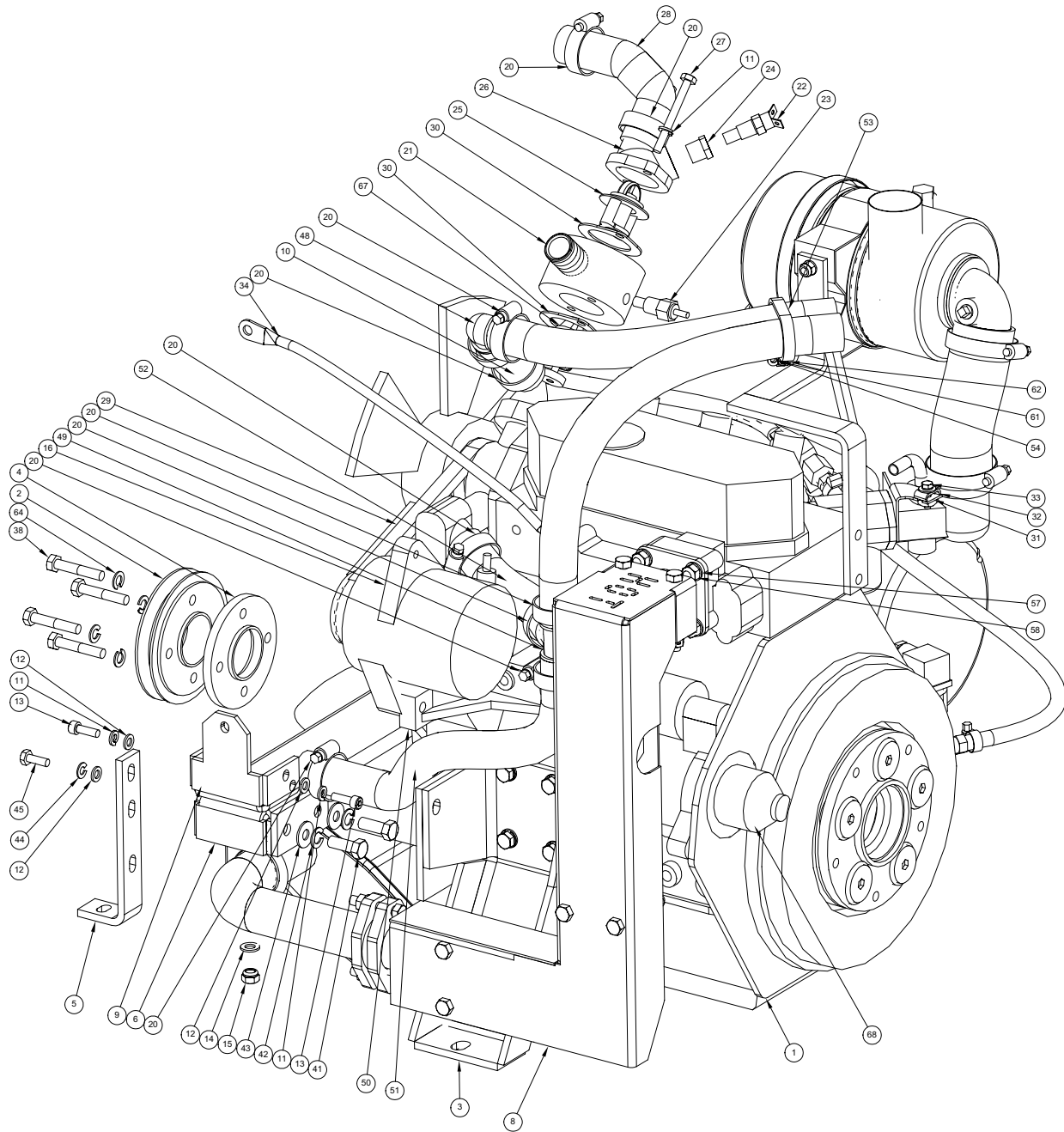

Engine Assembly Parts List

Item	Part Number	Description	Qty
1	000-047-016	Engine, Daihatsu 700G	1
2	000-109-078	Pulley, CAT Pump Drive	1
3	000-015-731	Bracket, Right Front Foot - Daihatsu	1
4	000-154-126	Spacer, Daihatsu Crank Shaft - CTS 450	1
5	000-015-872	Bracket, Radiator Mounting - CTS 450	2
6	000-015-831	Bracket, Radiator Channel	1
7	000-015-858	Bracket, Left Front Engine Mounting	1
8	610-003-029	Assembly, Exhaust - CTS 450 (Fig. 5-12)	1
9	000-015-737	Bracket, Radiator Mounting	2
10	000-068-250	Hose, 1" Green Stripe	1
11	000-174-017	Washer, 1/4" Lock	6
12	000-174-003	Washer, 1/4" Flat	8
13	000-143-077	Screw, 6mm x 20mm Lg. Socket Head	4
14	000-174-049	Washer, 5/16" Flat	10
15	000-094-038	Nut, 5/16"-18UNC Nylock	2
16	000-004-001	Alternator, Daihatsu 700G & 950G	1
17	000-052-058	Adapter, 3/8" FPT x 16mm Male Engine Oil Drain	1
18	000-052-104	Insert, #66 (3/8" NPT x 3/8" Barb)	1
19	000-049-014	Filter, 16HP Oil - All B & S	1
20	000-033-020	Clamp, Size #16 Hose	10
21	000-001-033	Adapter, Thermostat Housing	1
22	000-149-505	Sensor, 240° F Daihatsu Engine	1
23	000-149-039	Sender, Temperature	1
24	000-052-061	Bushing, 3/8" NPT x 1/4" FPT	1
25	000-149-023	Thermostat, 195° F Engine	1
26	000-047-016	Thermostat Housing - Daihatsu Engine	1
27	000-143-220	Screw, 6mm x 65mm Lg. Hex Head	2
28	000-068-500	Hose, Upper Radiator Daihatsu Engine	1
29	000-010-027	Belt, CTS 450 Alternator Replacement	1
30	000-057-050	Gasket, Thermostat Housing Daihatsu Engine	2

Engine Assembly Parts List

Item	Part Number	Description	Qty
31	000-015-782	Bracket, Choke Daihatsu (Manual)	1
32	000-033-124	Clamp, Daihatsu Choke (Manual)	1
33	000-143-551	Screw, Daihatsu Choke (Manual)	1
34	000-047-016	Bracket, Radiator Upper Support - Right - Raw	1
35	000-015-836	Bracket, Ignition Coil Mounting - CTS 450	1
36	000-047-016	Coil, Daihatsu 700G Engine	3
37	000-143-327	Screw, #10-32UNF x 0.50" Lg. Hex Head	6
38	000-143-184	Screw, 8mm x 45mm Lg. Hex Head Grd. 10.9	4
39	000-052-083	Elbow, 3/8" NPT Street x 45°	1
40	000-052-086	Elbow, 3/8" NPT Street	1
41	000-143-018	Screw, 3/8"-16UNC x 1.00" Lg. Grade 8	2
42	000-174-057	Washer, 3/8" Lock	2
43	000-174-032	Washer, 3/8" Flat	2
44	000-174-019	Washer, 1/4" Lock	4
45	000-143-001	Screw, 1/4"-20UNC x 0.75" Lg. Hex Head	4
46	000-174-005	Washer, 3/8" Flat	4
47	000-094-100	Nut, 3/8"-16UNC Hex Nylock	4
48	000-052-091	Elbow, 1" Barb x 1" Barb (For Radiator Hose)	1
49	000-052-648	Tee, 1" Barb x 1" Barb x 1" Barb	1
50	000-047-016	Bracket, Alternator Mounting - Lower - Daihatsu 700G/	1
51	000-068-032	Hose, 1" I.D. w/90° Preform Lower Rad.	1
52	000-068-500	Hose, Upper Radiator - Daihatsu Engine	1
53	000-033-067	Clamp, 2" Cushion Loop	1
54	000-143-126	Screw, #10-24UNC x 0.50" Lg. Hex Head	1
55	000-068-250	Hose, 1" I.D. Green Stripe	1
56	000-068-250	Hose, 1" I.D. Green Stripe	1
57	000-174-069	Washer, 5/16" Inconel Belleville, Diverter Valve	4
58	000-094-043	Nut, 8mm Hex	4
59	610-007-029	Assembly, Air Compressor - CTS 450 (Fig. 5-14)	1
60	000-010-124	Belt, Compressor Clutch Drive - CTS 450	1

Engine Assembly Parts List

Item	Part Number	Description	Qty
61	000-174-001	Washer, #10 Flat	1
62	000-094-034	Nut, #10-24UNC Nylock	1
63	610-003-029	Assembly, Air Cleaner - CTS 450 (Fig. 5-13)	1
64	000-174-018	Washer, 5/16" Lock	12
65	000-143-187	Screw, 8mm x 25mm Lg. Grade. 10.9 Hex Head	8
66	000-039-020	Coupler, C-Face Daihatsu - CTS 450	1
67	000-149-052	Thermostat, Daihatsu Engine Coolant	1
68	000-091-021	Starter, Daihatsu 700G Engine	1
69	610-003-029	Assembly, Compressor Check Valve (Fig. 5-15)	1
70	000-033-003	Clamp, Size #4 Mini	2
71	000-068-131	Hose, 1/4" I.D. Silicone - Bulk	1
72	000-033-005	Clamp, Size #5 Hose	2
73	000-068-131	Hose, 1/4" I.D. Silicone - Bulk	1
74	000-027-114	Cap, Radiator 3LC Engine - Daihatsu	1

Figure 5-12 Exhaust Assembly
C-5332 Rev C

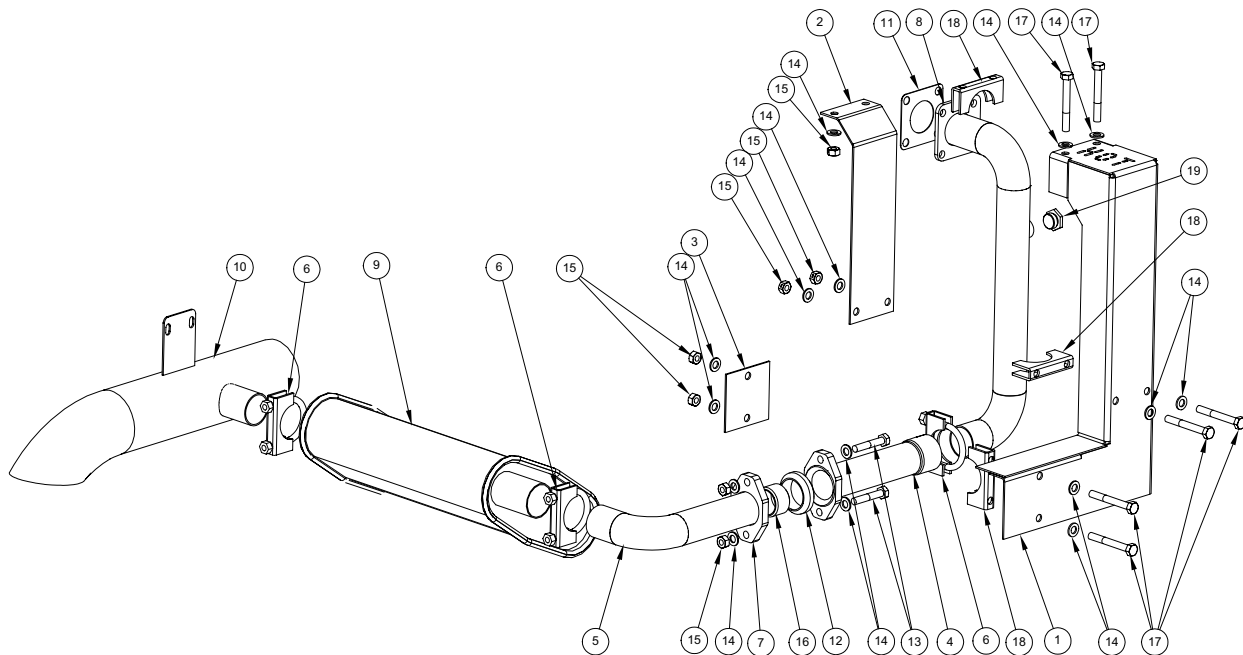

Exhaust Assembly Parts List

Item	Part Number	Description	Qty
1	000-041-400	Cover, Outer Exhaust - CTS 450	1
2	000-041-401	Cover, Inner Exhaust - CTS 450	1
3	000-015-822	Bracket, Exhaust Cover Securing - CTS 450	1
4	000-125-168	Tube, Exhaust Adjustment - CTS 450	1
5	000-125-169	Tube, Muffler Inlet - CTS 450	1
6	000-033-068	Clamp, 1-1/2" Muffler	3
7	000-105-181	Flange, Exhaust Donut	1
8	000-125-174	Tube, Exhaust Manifold Outlet - Weldment	1
9	000-093-091	Muffler, Daihatsu - Modified - CTS 450	1
10	000-001-112	Adapter, Final Exhaust - Weldment - CTS 450	1
11	000-057-070	Gasket, Manifold Daihatsu 700G & 950G	1
12	000-057-177	Gasket, Exhaust Donut 1.50"	1
13	000-143-124	Screw, 5/16"-18UNC x 1.75" Lg. Hex Head	2
14	000-174-049	Washer, 5/16" Flat	16
15	000-094-081	Nut, 5/16"-18UNC Hex 2-Way Locking	8
16	000-125-128	Tube, 1-3/8" OD x 1/8" Wall x 7/8" Long	1
17	000-143-106	Screw, 5/16"-18UNC x 2.5" Lg. Hex Head	6
18	000-033-068	Clamp, 1-1/2" Muffler (Base Only)	3
19	000-106-120	Plug, M18 x 1.5	1

Figure 5-13 Air Cleaner Assembly

C-5526 Rev A

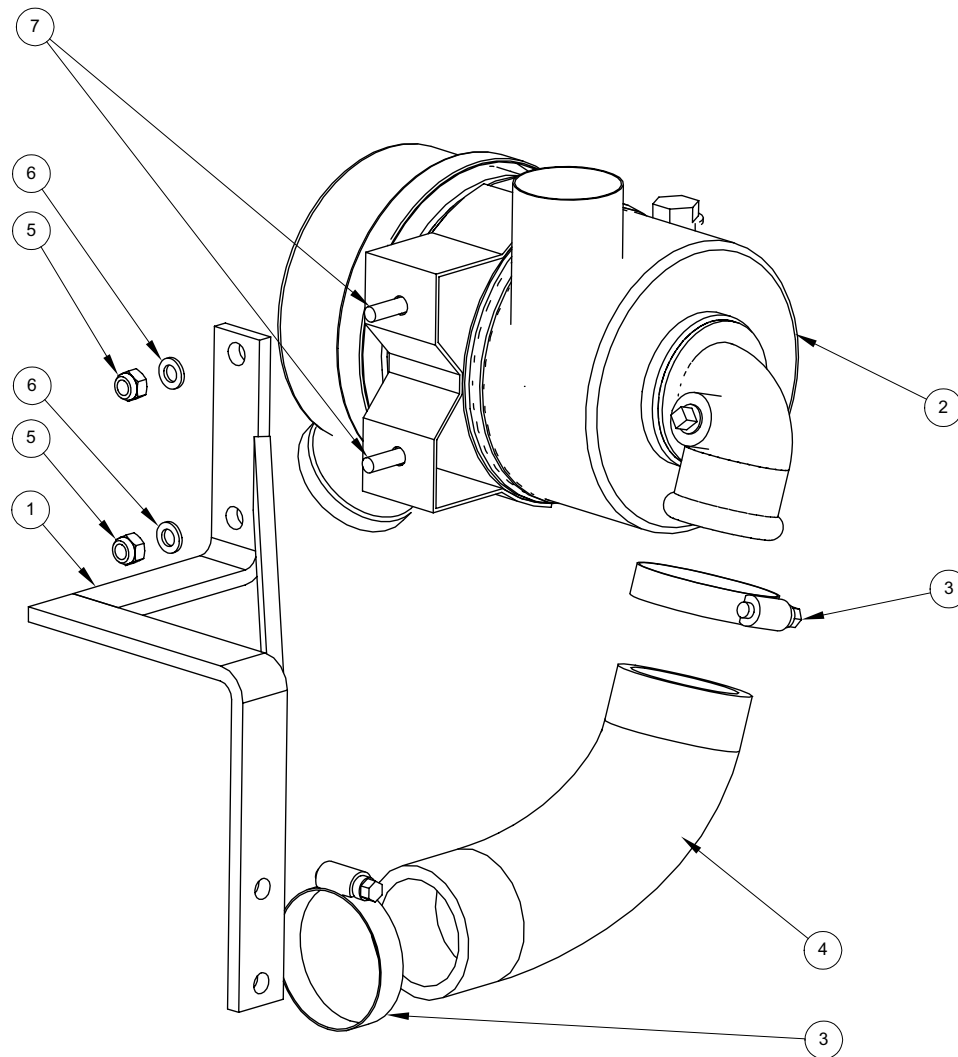

Air Cleaner Assembly Parts List

Item	Part Number	Description	Qty
1	000-015-844	Bracket, Air Cleaner Mounting - CTS 450	1
2	000-047-016	Air Cleaner - Daihatsu Engine	1
3	000-033-007	Clamp, #28 Hose	2
4	000-068-765	Hose, 1.75" x 'S' Bend - Modified	1
5	000-094-009	Nut, 1/4"-20UNC Hex Nylock	2
6	000-174-003	Washer, 1/4" Flat	2
7	000-143-001	Screw, 1/4"-20UNC x 0.75" Lg. Hex Head	2

Figure 5-14 Air Compressor Assembly
C-5525 Rev G

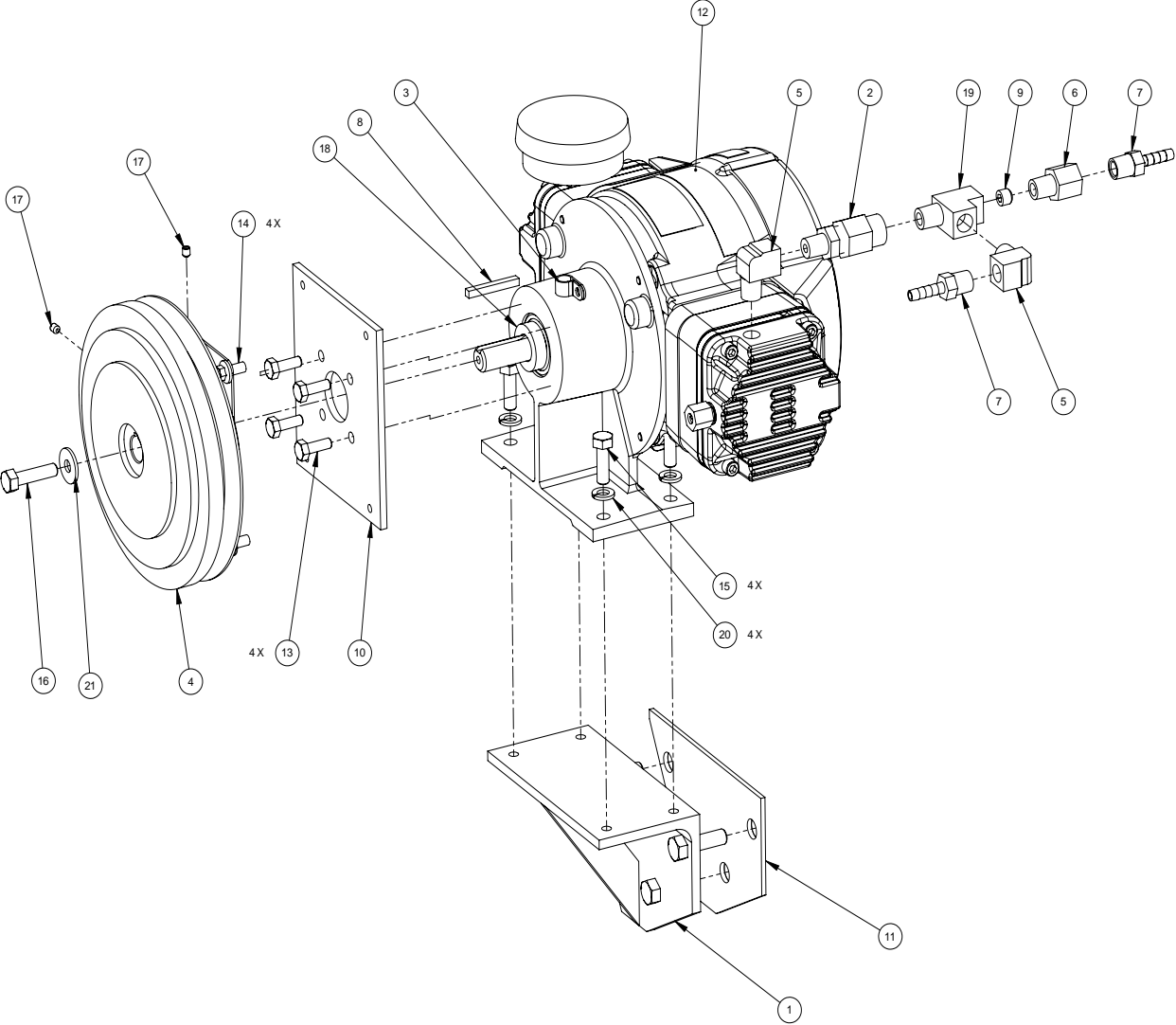

Air Compressor Assembly Parts List

Item	Part Number	Description	Qty
1	000-015-825	Bracket, Air Compressor Mounting - Coated	1
2	- - -	Check Valve (Comes w/Compressor)	1
3	000-033-128	Clamp, 3/8" Nylon Hose	1
4	000-036-010	Clutch, 7" O.D. 0.625" Bore Single Groove	1
5	000-052-085	Elbow, 1/4" NPT Street	2
6	000-052-423	Fitting, Bushing Modified Orifice Housing	1
7	000-052-100	Insert, #44	2
8	000-077-015	Key, 3/16" X 1-1/2"	1
9	000-180-004	Orifice, Set Screw - 0.033"	1
10	000-105-323	Plate, Compressor Clutch Mount	1
11	000-105-252	Plate, Compressor Spacer	1
12	000-111-204	Pump, Compressor (Thomas SGH-617B)	1
13	000-143-001	Screw, 1/4"-20UNC X 0.75" Lg. Hex Head	4
14	000-143-141	Screw, 1/4"-20UNC X 1/2" Lg. Whiz Lock	4
15	000-143-013	Screw, 5/16"-18UNC X 1.00" Lg. Hex Head Grade 8	4
16	000-143-014	Screw, 5/16"18UNC X 1.25" Lg. Hex Head	1
17	000-143-580	Set Screw, 5mm X 0.8 X 6mm Lg. Cup Point	2
18	000-020-064	Spacer, Compressor Clutch	1
19	000-052-090	Tee, 1/4" NPT Branch M-F-F	1
20	000-174-018	Washer, 5/16" Lock	4
21	000-174-170	Washer, Hardened, 5/16"	1

Figure 5-15 Compressor Check Valve Assembly
C-6246 Rev A

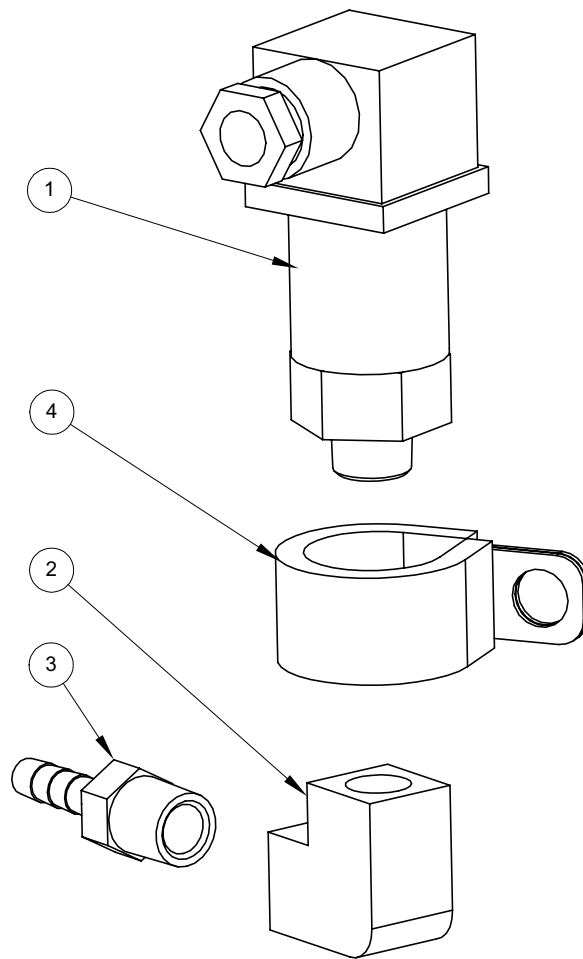

Compressor Check Valve Assembly Parts List

Item	Part Number	Description	Qty
1	000-157-148	Switch, Pressure 125 PSI	1
2	000-052-088	Elbow, 1/4" FPT x FPT	1
3	000-052-100	Insert, #44 (1/4" NPT x 1/4" Barb)	1
4	000-033-117	Clamp, 1" Cushion Loop w/ 7/16" Mount Hole	1

Figure 5-16 Blower Assembly

D-5371 Rev E

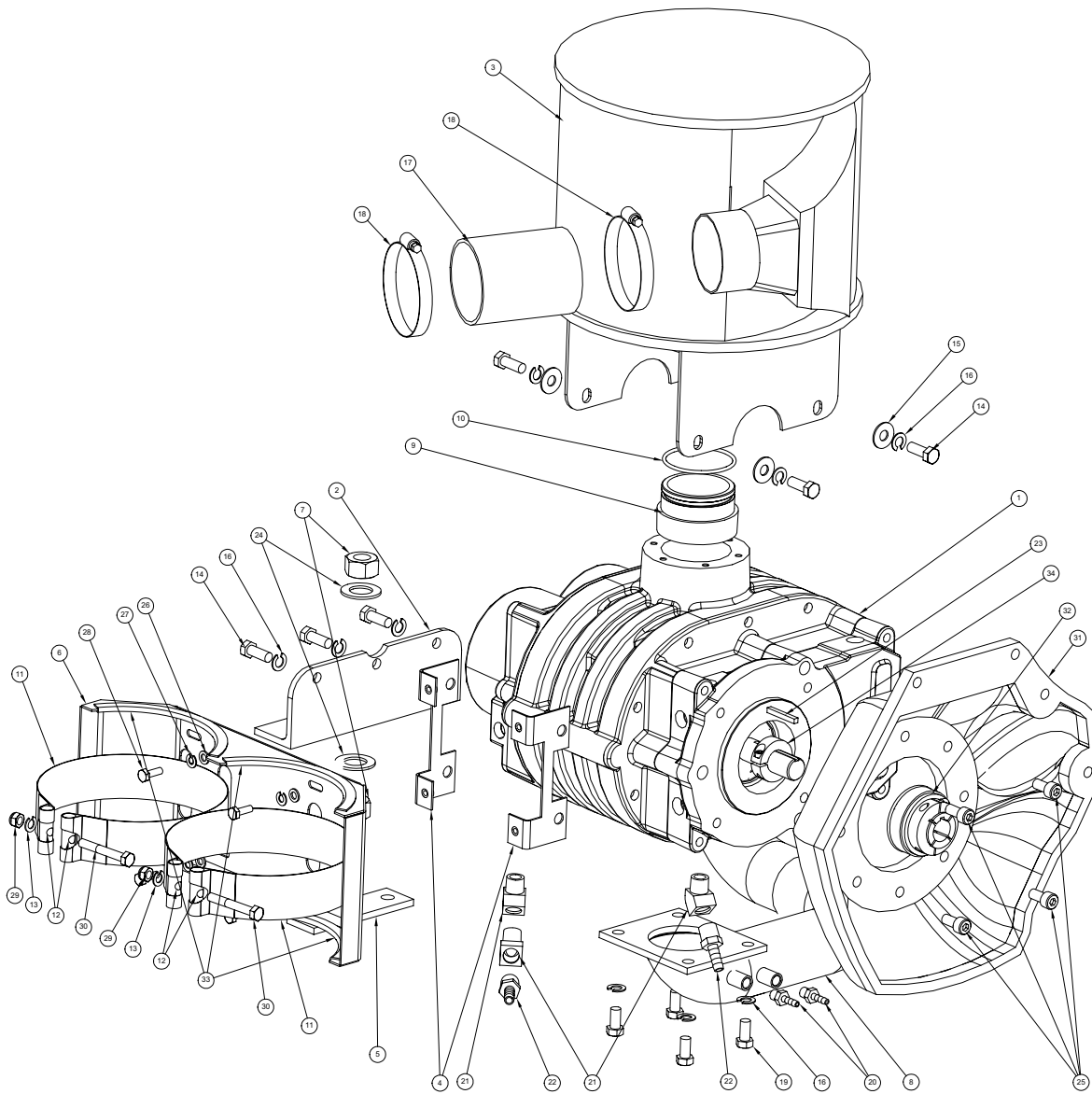

Blower Assembly Parts List

Item	Part Number	Description	Qty
1	000-111-165	Blower, 4005 C-Face	1
2	000-015-827	Bracket, Blower Foot - CTS 450	1
3	000-093-084	Silencer, 3" Blower - CTS 450	1

Blower Assembly Parts List

Item	Part Number	Description	Qty
4	000-015-840	Plate, Saddle Mounting - After Burner - CTS 450	2
5	000-015-829	Bracket, Blower Foot Adjustment - CTS 450	1
6	000-015-830	Bracket, Dual After Burner Saddle - Weldment	1
7	000-094-080	Nut, 3/4"-10UNC Hex	2
8	000-001-113	Adapter, Blower Inlet - CTS 450	1
9	000-001-024	Adapter, Blower To Silencer	1
10	000-097-029	O-Ring, Blower To Silencer (2 3/4" Id x 2 1/2" Od x 1/8"	1
11	000-033-123	Clamp, After Burner Mount - Boxxer 421	2
12	000-141-033	Rod, Heat Exchanger Strap - Retainer	4
13	000-174-018	Washer, 5/16" Lock	2
14	000-143-018	Screw, 3/8"-16UNC x 1.00" Lg. Grade 8	7
15	000-174-005	Washer, 3/8" Flat	4
16	000-174-021	Washer, 3/8" Lock	11
17	000-068-398	Hose, 3" Blue Silicone x 3 Ply	1
18	000-033-013	Clamp, Size #48 Hose	2
19	000-143-017	Screw, 3/8"-16UNC x 0.75" Lg. Hex Head Grd. 8	4
20	000-052-293	Insert, #23 (1/8" NPT x 3/16" Barb)	2
21	000-052-083	Elbow, 3/8" NPT Street x 45°	3
22	000-052-104	Insert, #66 (3/8" NPT x 3/8" Barb)	2
23	000-077-011	Key, 3/16" x 1.50" Lg. Class 2 Fit	1
24	000-174-028	Washer, 7/8" I.D. x 1.50" O.D. x 0.090" Thk.	2
25	00-143-094-	Screw, 3/8"-16UNC x 0.75" Lg. Socket Head	4
26	000-174-003	Washer, 1/4" Flat	4
27	000-174-019	Washer, 1/4" Lock	4
28	000-143-001	Screw, 1/4"-20UNC x 0.75" Lg. Hex Head	4
29	000-094-038	Nut, 5/16"-18UNC Nylock	2
30	000-143-092	Screw, 5/16"-18UNC x 2.25" Lg. Hex Head	2
31	000-042-008	Housing, Bell - CTS 450	1
32	000-039-020	Coupler, C-Face Daihatsu - CTS 450	1
33	000-131-027	Trimlok, Crossfire Brow	4

Figure 5-17 Dump & Vacuum Bracket Assembly - Front
D-5520 Rev D

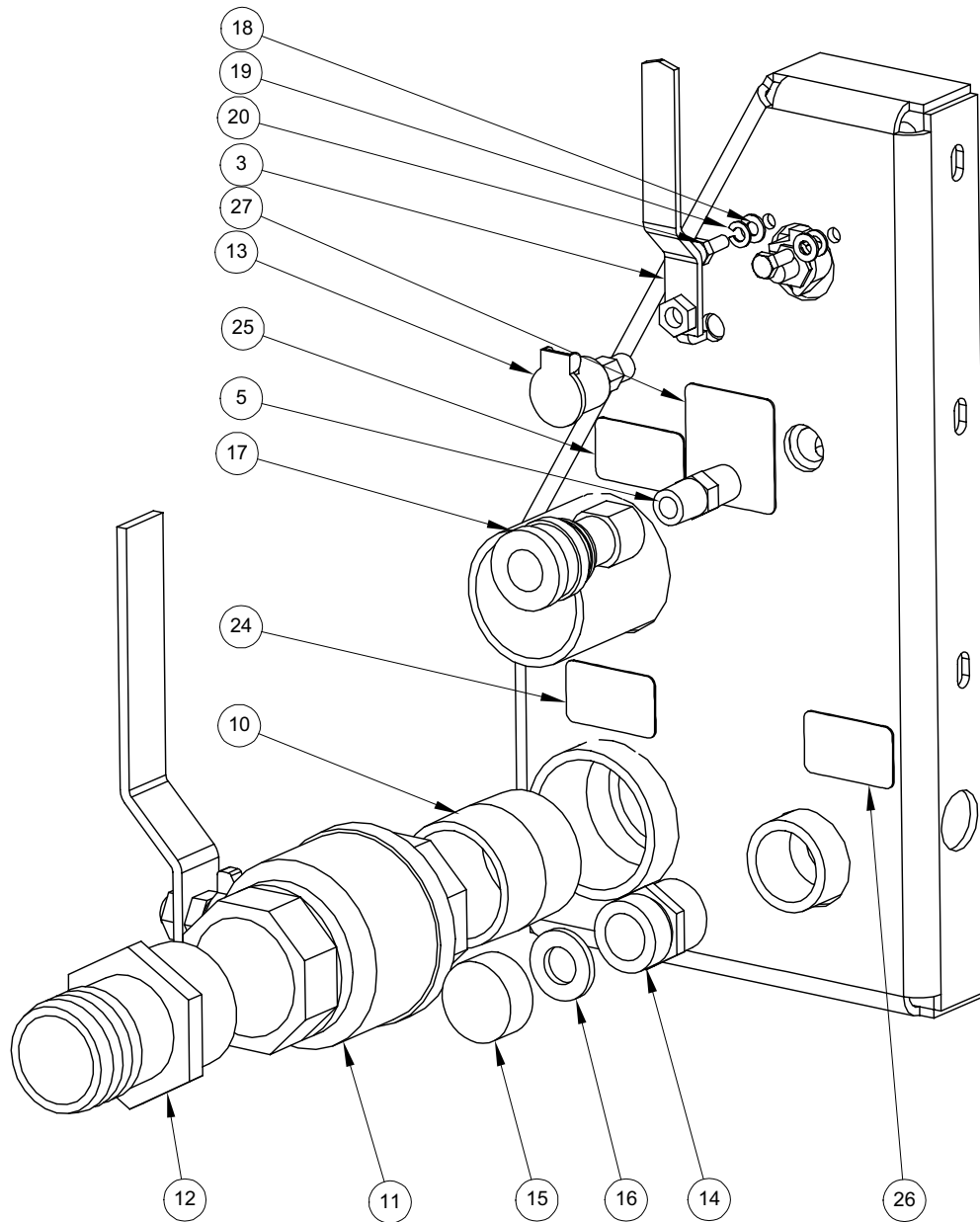
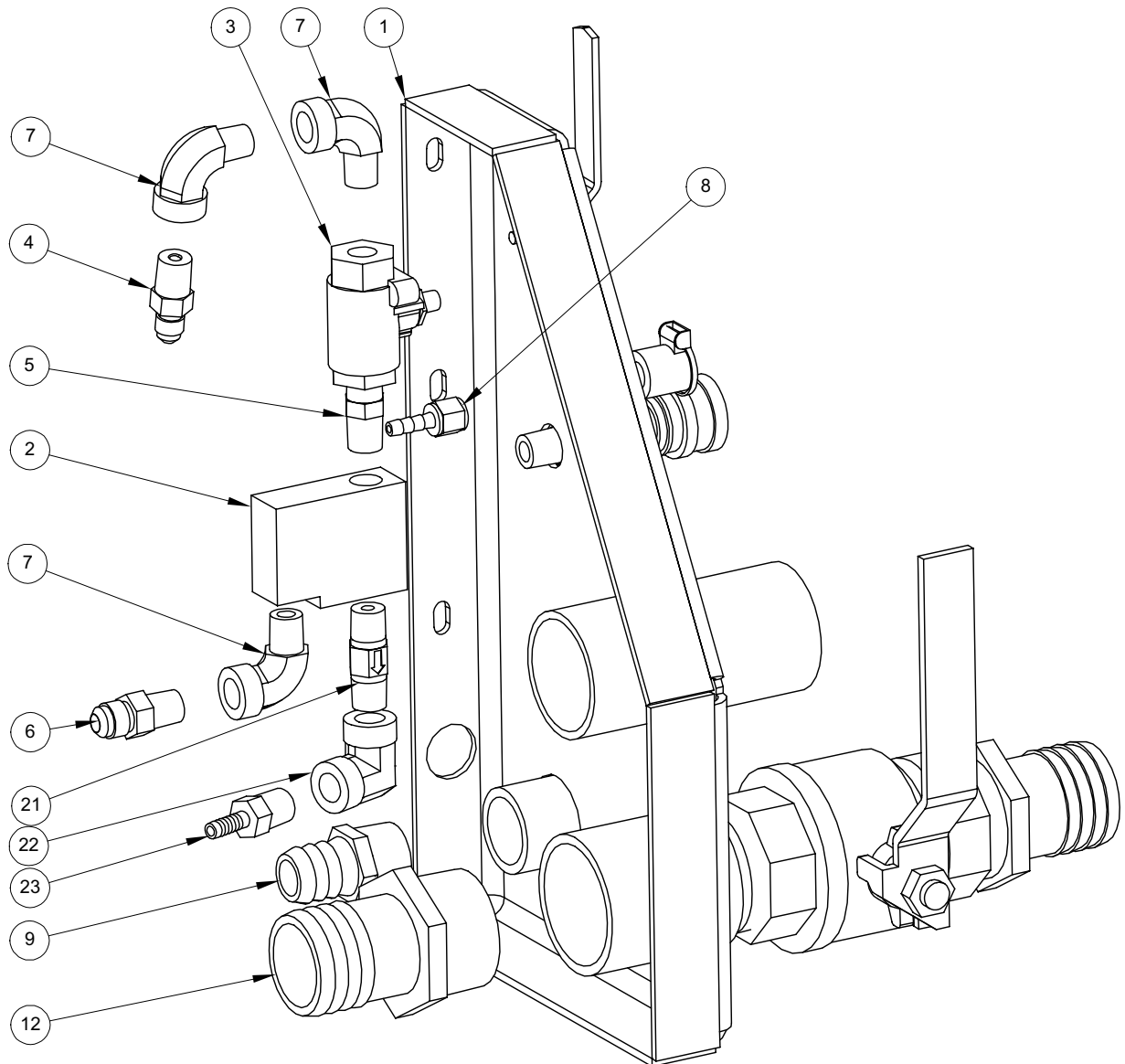

Figure 5-18 Dump & Vacuum Bracket Assembly - Rear
D-5520 Rev D



Dump & Vacuum Bracket Assembly Parts List

Item	Part Number	Description	Qty
1	000-015-821	Bracket, Dump & Vacuum Hose - Weldment - CTS 450	1
2	000-090-018	Manifold, Hi PSI s/s	1
3	000-169-095	Valve, 1/4" NPT Panel Mount - Full Port Ball	1
4	000-052-526	Nipple, 1/4" NPT x 1/4" JIC	1
5	000-052-095	Nipple, 1/4" NPT Hex	2
6	000-052-506	Nipple, 1/4" NPT x 9/16"-18UNF x 37° JIC	1
7	000-052-691	Elbow, 1/4" Street s/s	3
8	000-052-096	Insert, #F23 (1/8" FPT x 3/16" Barb)	1
9	000-052-338	Insert, #1212 (3/4" NPT x 3/4" Barb)	1
10	000-052-182	Nipple, 1-1/2" NPT Close Galvanized	1
11	000-169-022	Valve, 1-1/2" Full Port Ball	1
12	000-052-226	Insert, 1-1/2" NPT x 1-1/2" Barb (Grey)	2
13	000-052-272	Cup, Gravity Feed Oil Blower Lubrication Port	1
14	000-052-281	Nipple, 3/4" NPT x 3/4" Male Garden Hose	1
15	000-027-014	Cap, Garden Hose	1
16	000-057-055	Gasket, Garden Hose	1
17	000-052-690	Quick Connect, Female - CTS 450	1
18	000-174-001	Washer, #10 Flat	2
19	000-174-014	Washer, #10 Lock	2
20	000-143-126	Screw, #10-24UNC x 0.50" Lg. Hex Head	2
21	000-169-195	Valve, 200 PSI Pop Off	1
22	000-052-734	Elbow, 1/4" FPT x 1/4" FPT s/s	1
23	000-052-696	Insert, #44 (1/4" NPT x 1/4" Barb) s/s	1
24	000-081-215	Label, Drain Valve - CTS 450	1
25	000-081-215	Label, Vacuum Inlet - CTS 450	1
26	000-081-215	Label, Auto Pump-Out - CTS 450	1
27	000-081-215	Label, Lubricate Blower Daily - CTS 450	1

Figure 5-19 Coolant Heat Exchanger Assembly
D-5523 Rev A

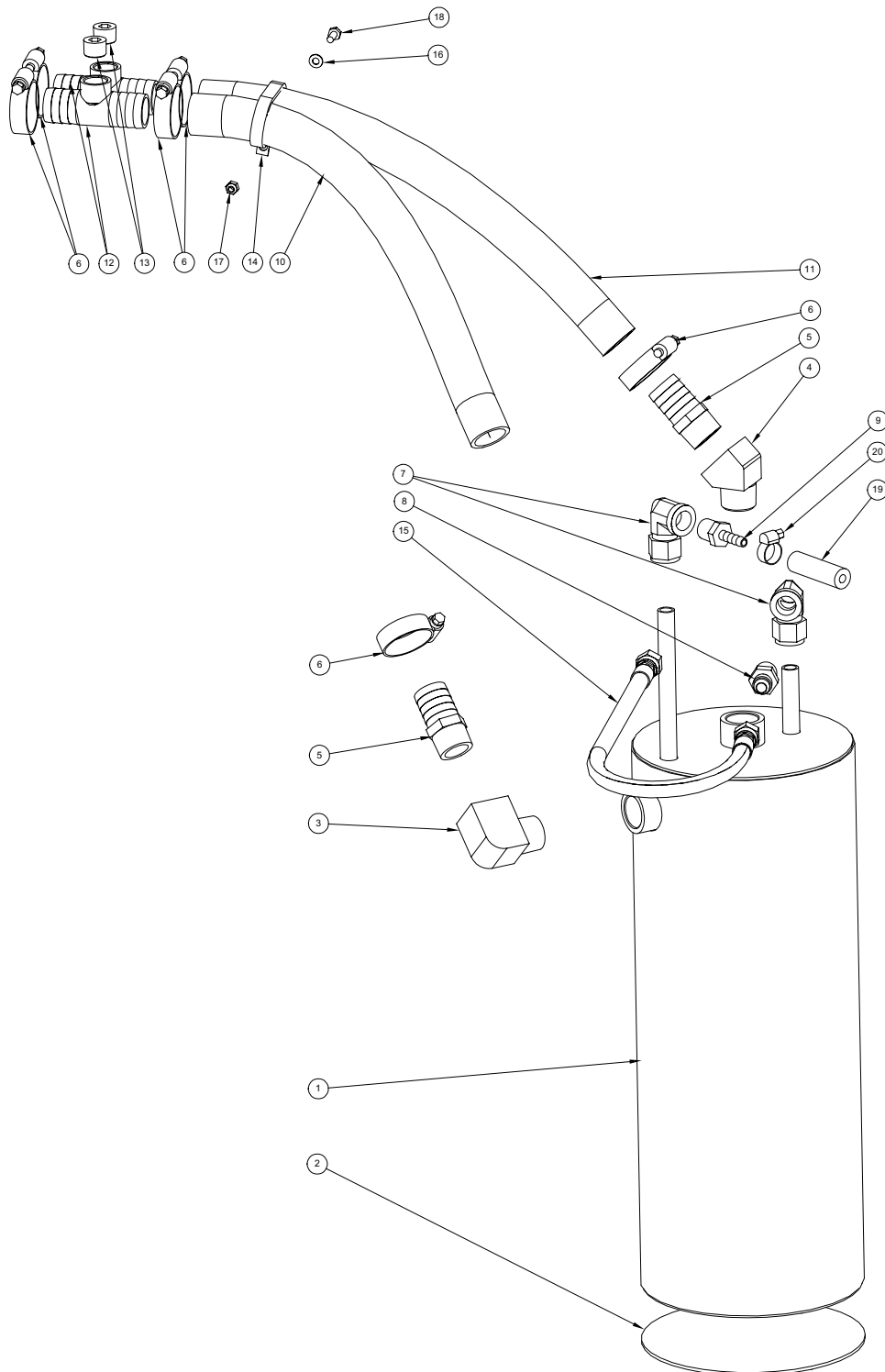

Coolant Heat Exchanger Assembly Parts List

Item	Part Number	Description	Qty
1	000-038-065	Core, Coolant Heat Exchanger - Weldment - CTS 450	1
2	000-108-131	Protector, HX Pad 6.63" O.D.	1
3	000-052-340	Elbow, 3/4" NPT Street	1
4	000-052-384	Elbow, 3/4" NPT x 45°	1
5	000-052-125	Insert, #1216 (3/4" NPT x 1" Barb)	2
6	000-033-020	Clamp, Size #16 Hose	6
7	000-052-600	Elbow, 1/2" Tube x 3/8" FPT	2
8	000-052-507	Nipple, 3/8" NPT x 9/16"-18 37° JIC	1
9	000-052-749	Insert, #64 (3/8" NPT x 1/4" Barb)	1
10	000-068-250	Hose, 1" I.D. Green Stripe	1
11	000-068-250	Hose, 1" I.D. Green Stripe	1
12	000-001-019	Adapter, Lower Radiator Tee (1" Barb x 1" Barb x 3/8"	2
13	000-106-008	Plug, 3/8" NPT Allen Head	2
14	000-033-067	Clamp, 2" Cushion Loop	1
15	000-068-724	Hose, 3/8" x 18" Lg. Teflon w/ JIC Ends	1
16	000-174-001	Washer, #10 Flat	1
17	000-094-034	Nut, #10-24UNC Nylock	1
18	000-143-126	Screw, #10-24UNC x 0.50" Lg. Hex Head	1
19	000-068-015	Hose, 1/4" I.D. - Bulk	1
20	000-033-003	Clamp, Size #4 Mini	1

Figure 5-20 Blower Exhaust Heat Exchanger Assembly
D-5522 Rev -

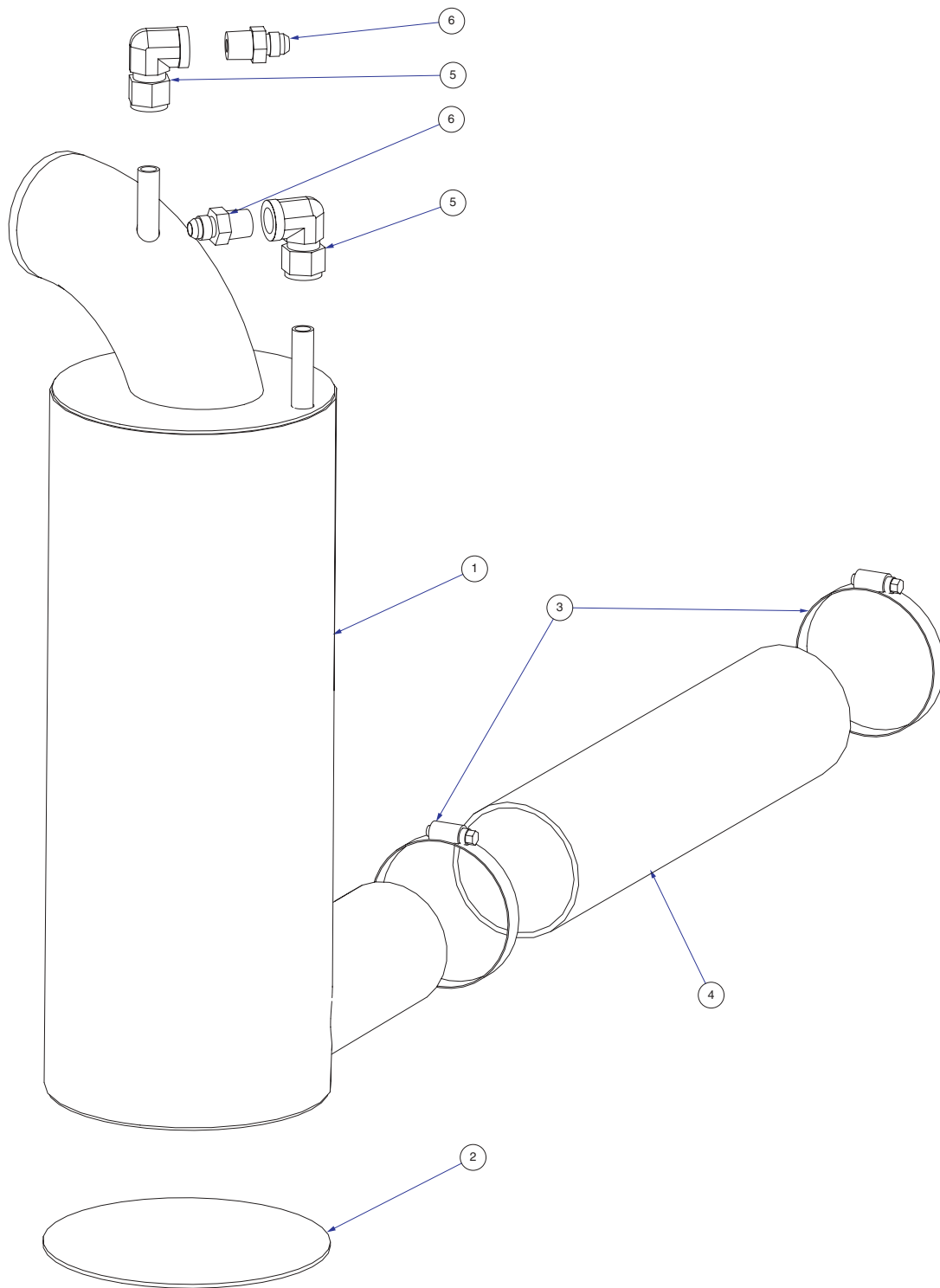

Blower Exhaust Heat Exchanger Assembly Parts List

Item	Part Number	Description	Qty
1	000-038-070	Core, Blower Exhaust HX - Weldment - CTS 450	1
2	000-108-131	Protector, HX Pad 6.63" O.D.	1
3	000-033-013	Clamp, Size #48 Hose	2
4	000-068-398	Hose, 3" I.D. 3 Ply Silicone	1
5	000-052-600	Elbow, 1/2" Tube x 3/8" FPT	2
6	000-052-507	Nipple, 3/8" NPT x 9/16"-18 37° JIC	2

Figure 5-21 15 Gallon Chemical Jugs Assembly
D-6117 Rev C

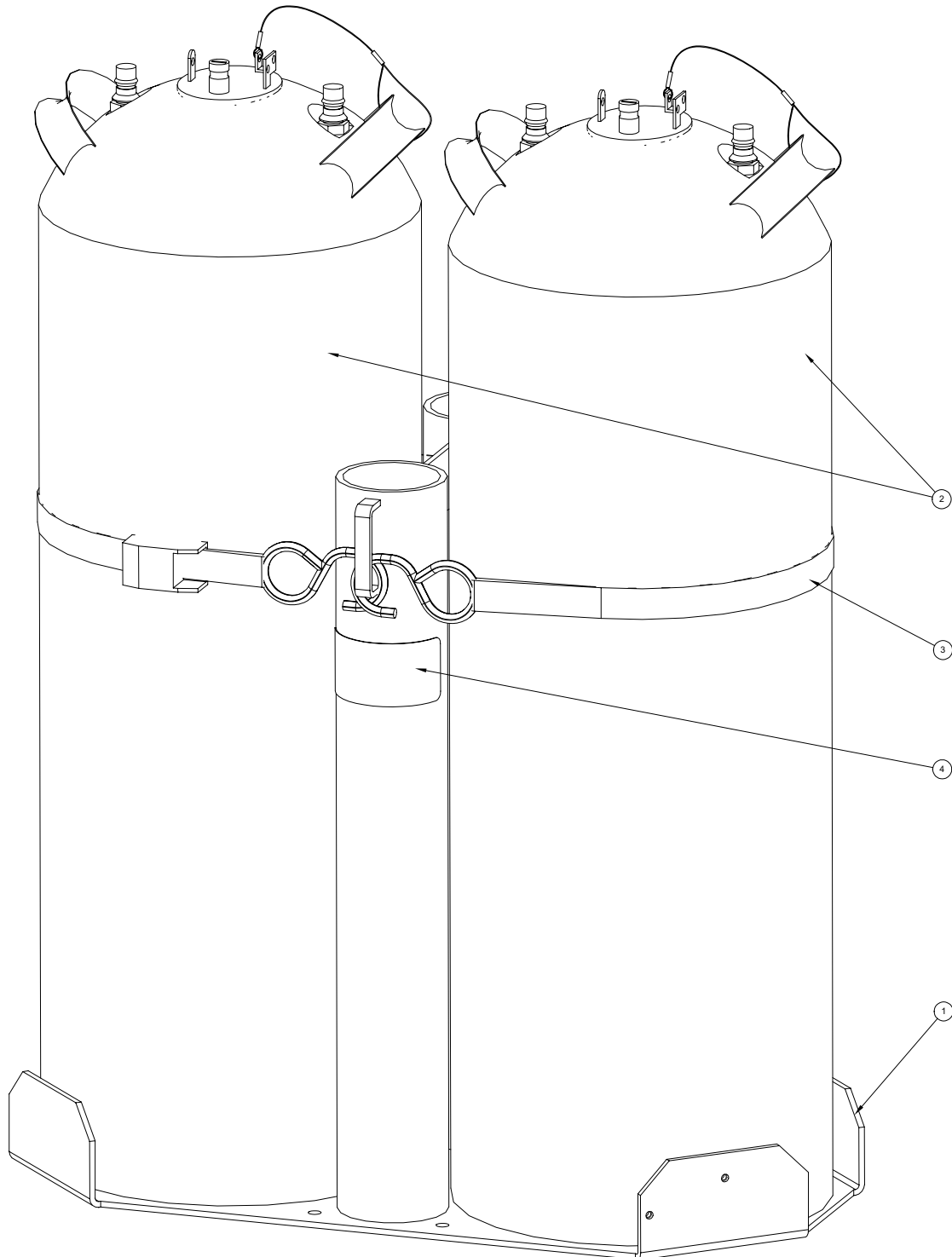

15 Gallon Chemical Jugs Assembly Parts List

Item	Part Number	Description	Qty
1	000-015-869	Bracket, 15 Gallon Tank	1
2	000-159-127	Tank, 15 Gallon Chemical - CTS 450 (Fig. 5-22)	2
3	000-108-141	Tie Down Strap	1
4	000-081-218	Label, Caution - Tank - CTS 450	1

Figure 5-22 15 Gallon Chemical Tank Assembly
C-6109 Rev -

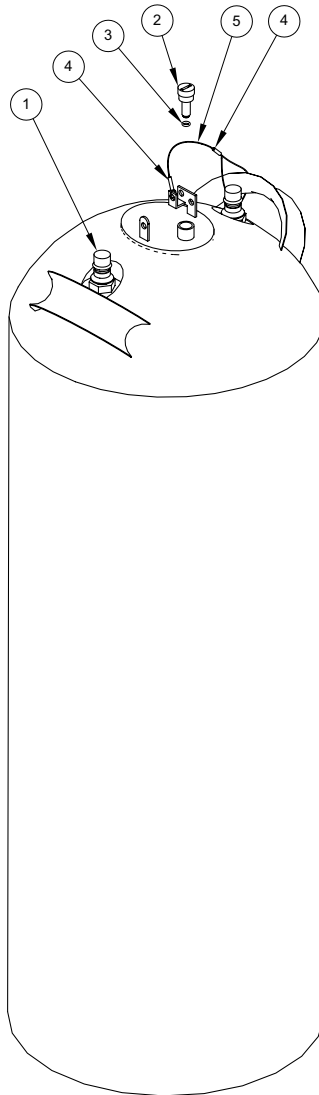

15 Gallon Chemical Tank Assembly Parts List

Item	Part Number	Description	Qty
1	000-159-126	Tank, 15 Gallon Chemical - CTS 450	1
2	000-106-055	Plug, 1/4 Ss Chemical Container - CTS 450	1
3	000-097-006	O-Ring, #8 Buna - New Rx Skid	1
4	000-033-032	Clamp, CDS Throttle Cable	2
5	000-025-008	Cable, 150 Lb Test	1

CTS 450 Hot Carbonating Truckmount System

Figure 5-23 100 Gallon Recovery Tank Assembly
D-5859 Rev D

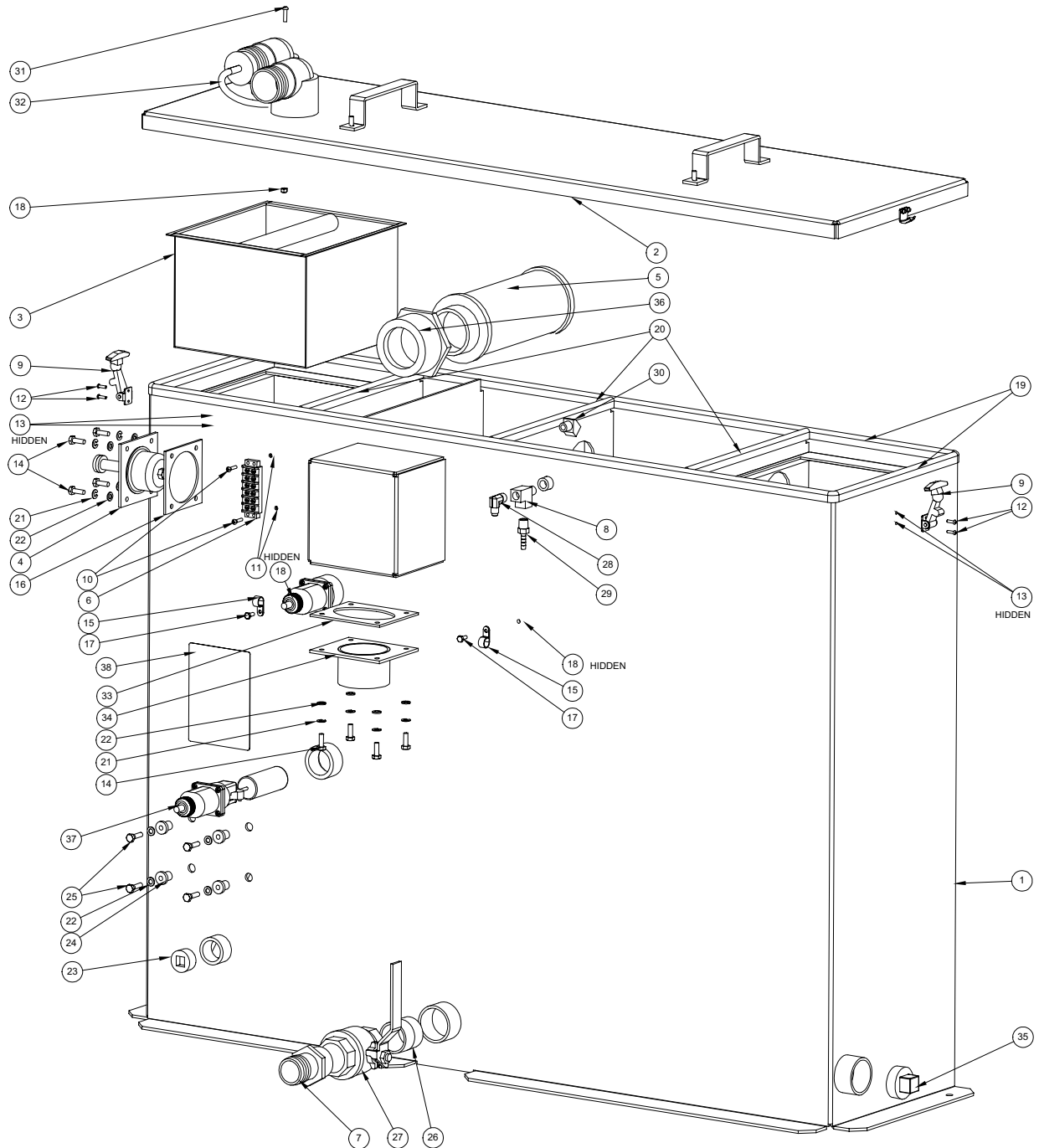

100 Gallon Recovery Tank Assembly Parts List

Item	Part Number	Description	Qty
1	000-159-066	Recovery Tank - Weldment - Maxx 450D/470D	1
2	Fig. 5-24	Assembly, Recovery Tank Cover	1
3	000-049-057	Filter Basket, Recovery Tank	1
4	Fig. 5-25	Assembly, Vacuum Relief Valve	1
5	000-049-008	Filter, 2-1/2" Recovery Tank - CDS 4.6/Boxxer 421	1
6	000-012-002	Block, 6 Post Terminal	1
7	000-052-226	Insert, 1-1/2" NPT x 1-1/2" Barb (Grey)	1
8	000-052-090	Tee, 1/4" NPT Branch M-F-F	1
9	000-086-008	Latch, Bungie	2
10	000-143-051	Screw, #8-32UNC x 0.75" Lg. Binder Head Phillips	2
11	000-094-059	Nut, #8-32UNF Nylock	2
12	000-143-539	Screw, #6-32UNC x 0.50" Lg. Button Head Allen	4
13	000-094-063	Nut, #6-32UNC Nylock	4
14	000-143-001	Screw, 1/4"-20UNC x 0.75" Lg. Hex Head	8
15	000-033-022	Clamp, 1/2" Nylon Hose	2
16	000-057-178	Gasket, Vacuum Relief Plate	1
17	000-143-126	Screw, #10-24UNC x 0.50" Lg. Hex Head	2
18	000-094-034	Nut, #10-24UNC Nylock	3
19	000-131-021	Trimlok, 5/8" x 1/8" Waste Tank	1
20	000-131-021	Trimlok, 5/8" x 1/8" Waste Tank	3
21	000-174-019	Washer, 1/4" Lock	8
22	000-174-003	Washer, 1/4" Flat	12
23	000-106-049	Plug, 1" NPT Allen Head	1
24	000-094-113	Nut, 1/4"-20UNC Neoprene Wellnut	4
25	000-143-002	Screw, 1/4"-20UNC x 1.00" Lg. Hex Head	4
26	000-052-182	Nipple, 1-1/2" NPT Close Galvanized	1
27	000-169-022	Valve, 1-1/2" Full Port Ball	1
28	000-052-532	Elbow, 1/4" SAE x 1/4" JIC x 90°	1
29	000-052-100	Insert, #44 (1/4" NPT x 1/4" Barb)	1
30	000-052-082	Elbow, 1/4" NPT Street x 45°	1

100 Gallon Recovery Tank Assembly Parts List

Item	Part Number	Description	Qty
31	000-143-168	Screw, #10-24UNC x 0.75" Lg.	1
32	000-078-039	Vacuum Inlet Stopper Assembly - Recovery Tank	1
33	000-057-195	Gasket, Blower Inlet Adapter - Maxx	1
34	000-001-121	Adapter, Recovery Tank Outlet - Maxx - 100 Gal.	1
35	000-106-019	Plug, 1-1/2" NPT	1
36	000-052-731	Bushing, 3" NPT x 2-1/2" FPT Pvc Sch 40	1
37	000-157-090	Float, Lever Switch	2
38	000-081-215	Label, Maintenance & Lubrication Schedule	1

Figure 5-24 100 Gallon Recovery Tank Cover Assembly
C-5960 Rev A

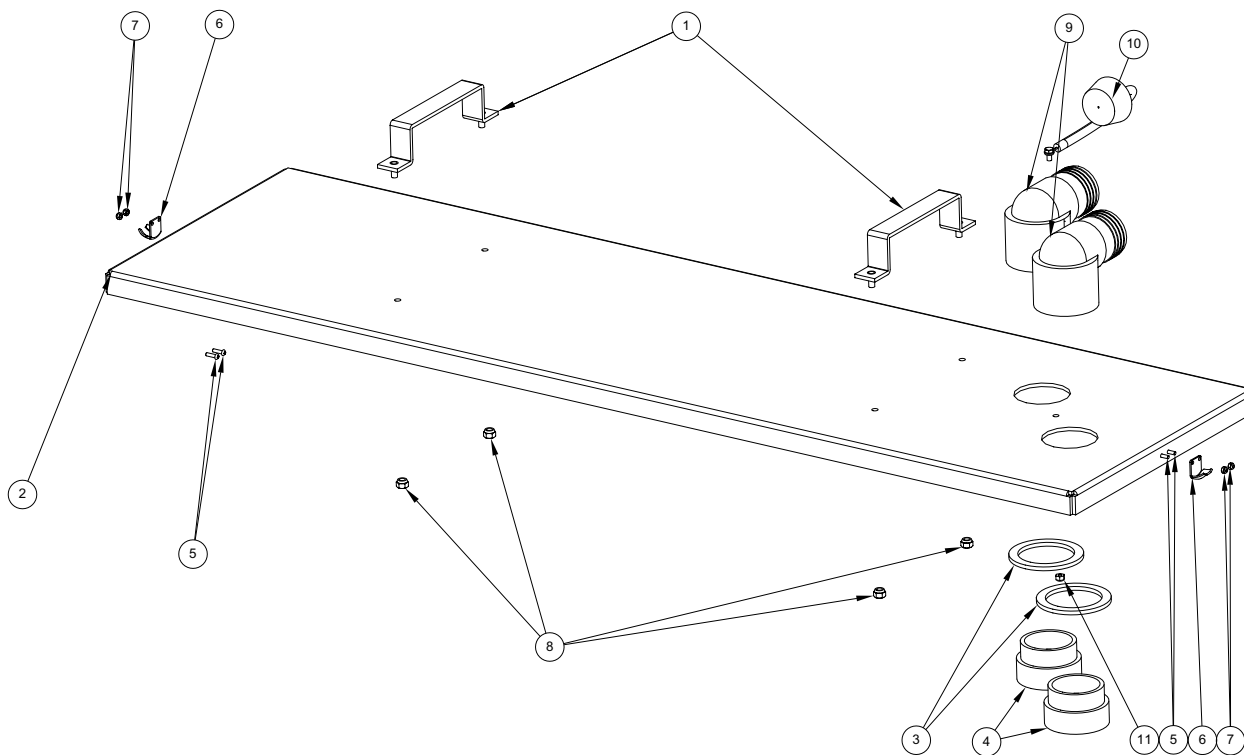

100 Gallon Recovery Tank Cover Assembly Parts List

Item	Part Number	Description	Qty
1	000-061-059	Handle, Recovery Tank Cover - Maxx	2
2	000-041-240	Cover, Recovery Tank - Weldment	1
3	000-057-015	Gasket, 1-1/2" Bulkhead Fitting	2
4	000-052-219	Adapter, 2" NPT x 2" F Slip	2
5	000-143-539	Screw, #6-32UNC x 0.50" Lg. Button Head Allen	4
6	000-086-008	Latch, Bungie - Strike	2
7	000-094-063	Nut, #6-32UNC Nylock	4
8	000-094-009	Nut, 1/4"-20UNC Hex Nylock	4
9	000-052-222	Elbow, 2" Barb x 2" FPT	2
10	000-078-039	Vacuum Inlet Stopper Assembly - Recovery Tank	1
11	000-094-034	Nut, #10-24UNC Nylock	1

Figure 5-25 Vacuum Relief Valve Assembly

C-4237 Rev A

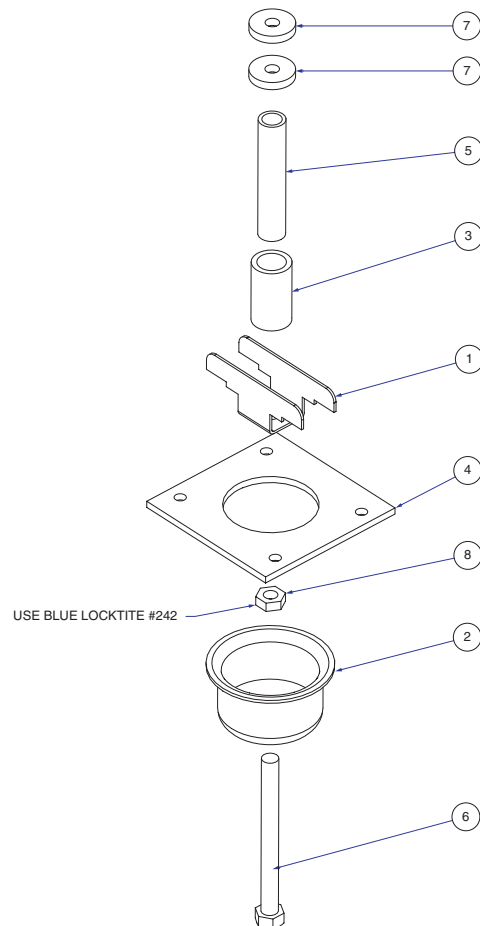

Vacuum Relief Valve Assembly Parts List

Item	Part Number	Description	Qty
1	000-015-182	Bracket, Vacuum Relief Valve	1
2	000-027-032	Cap, Vacuum Relief Valve	1
3	000-125-111	Pipe, Vacuum Relief Spring Guide	1
4	000-105-067	Plate, Vacuum Relief Valve Mounting	1
5	000-155-026	Spring, Vacuum Relief	1
6	000-143-198	Screw, 3/8"-16UNC x 4" Lg. Hex Head Full Thread	1
7	000-094-077	Nut, 3/8"-16UNC x 1.00" O.D. Knurled	2
8	000-094-101	Nut, 3/8"-16UNC Hex Jam	1

CTS 450 Diesel Assemblies & Parts

Figure 5-26 Machine Assembly CTS 450 Diesel - Front View
D-5865 Rev C

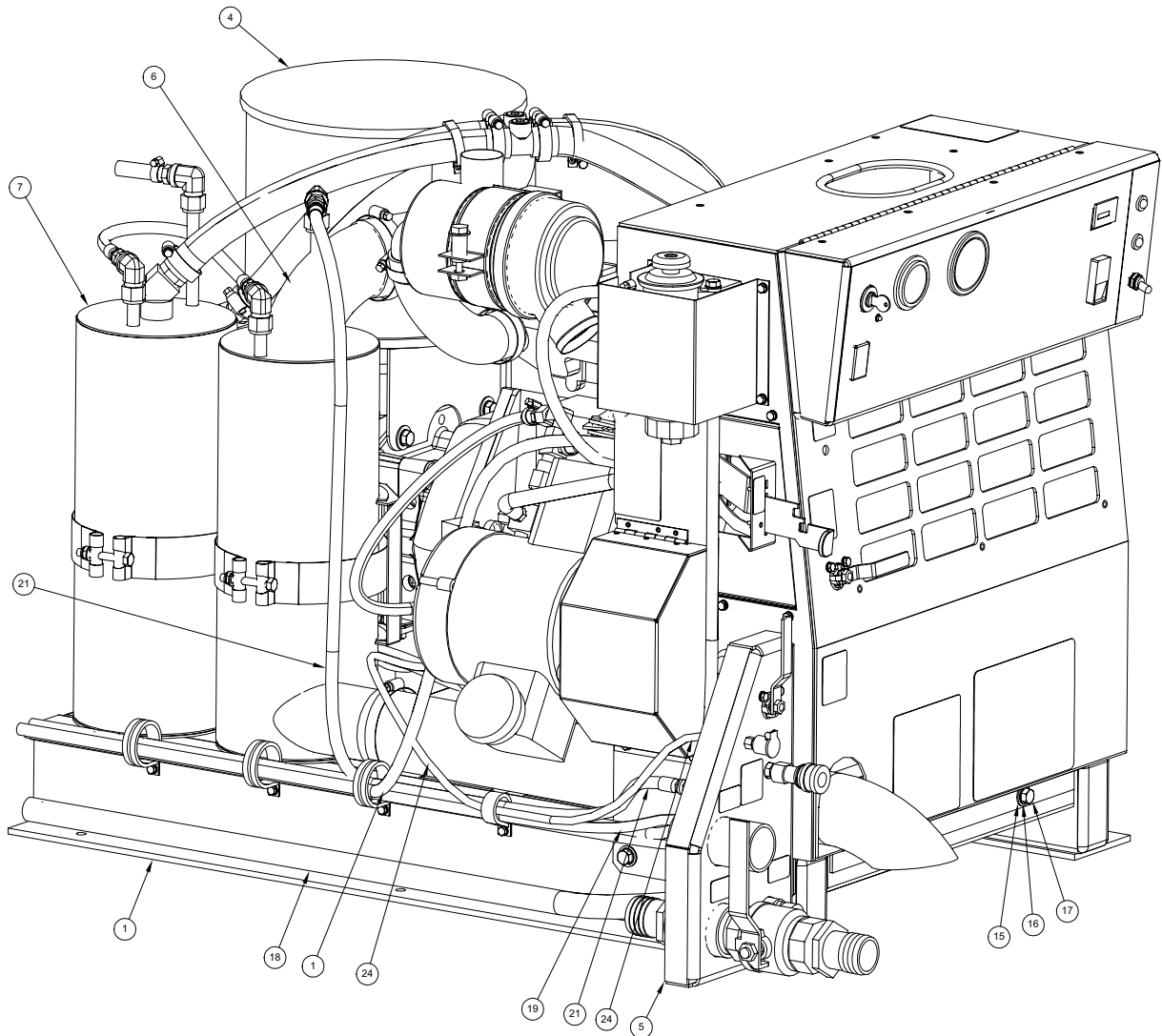
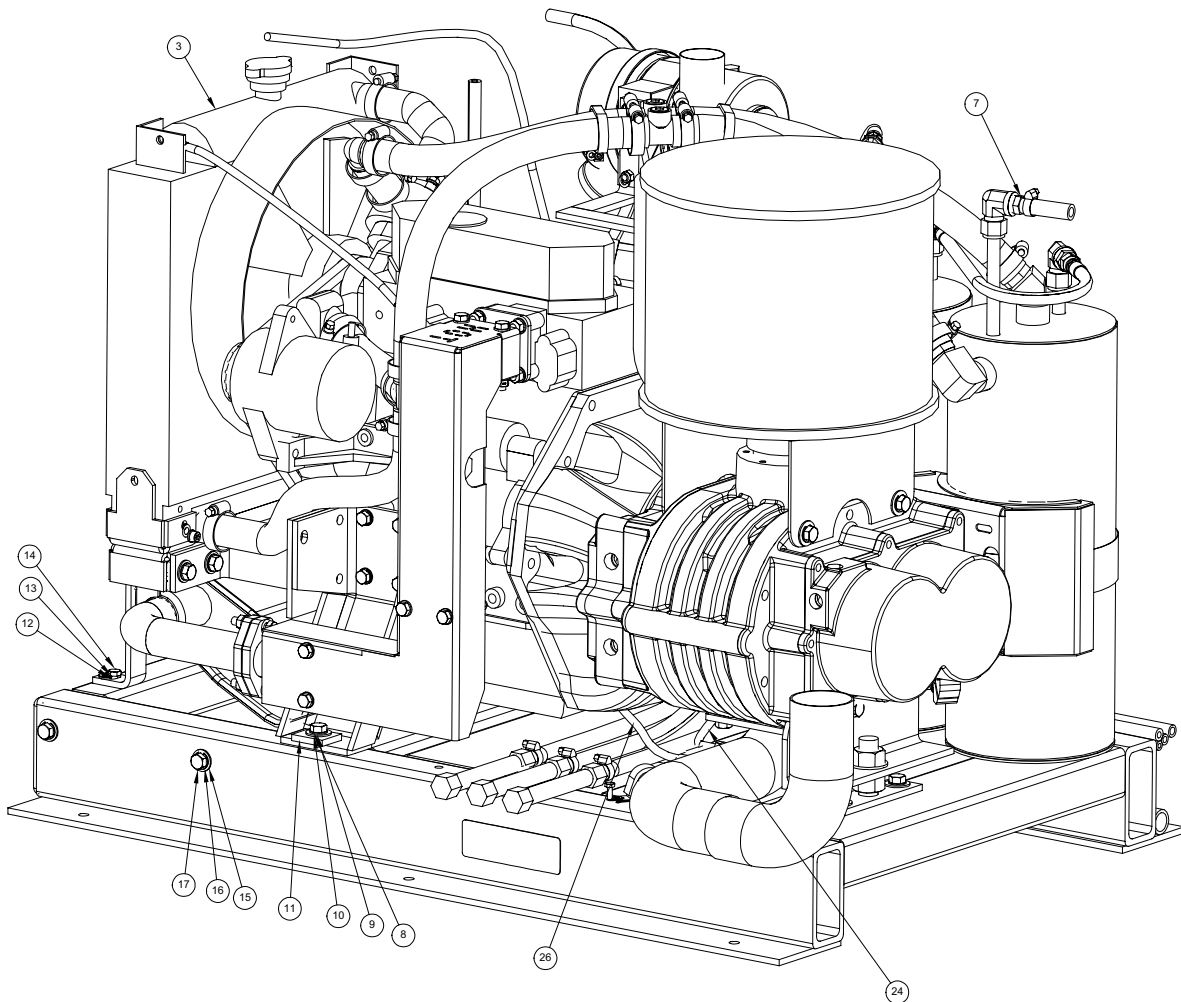
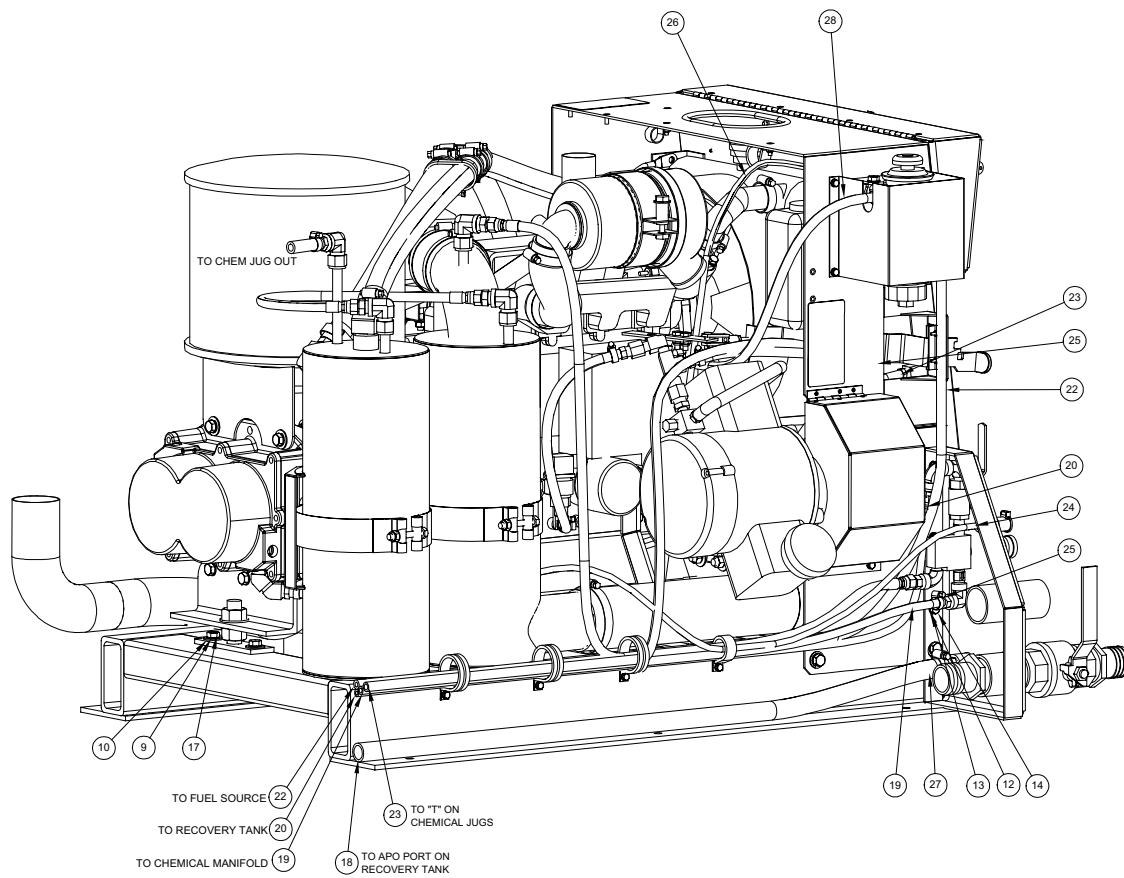

Figure 5-27 Machine Assembly CTS 450 Diesel - Rear View
D-5865 Rev C



CTS 450 *Hot Carbonating Truckmount System*

Figure 5-28 Machine Assembly CTS 450 Diesel - Side View
D-5865 Rev C



Machine Assembly Parts List

Item	Part Number	Description	Qty
1	610-001-031	Assembly, Frame - CTS 450 Diesel (Fig. 6-32)	1
2	610-020-031	Assembly, Dash - CTS 450 Diesel (Fig. 6-29 & 6-30)	1
3	610-003-031	Assembly, Engine - CTS 450 Diesel (Fig. 6-33 & 6-34)	1
4	610-002-029	Assembly, Blower - CTS 450 Diesel (Fig. 6-36)	1
5	610-019-029	Assembly, Dump & Vacuum Bracket (Fig. 6-17 & 6-18)	1
6	610-005-029	Assembly, Blower Exhaust Heat Exchanger (Fig. 6-20)	1
7	610-006-029	Assembly, Coolant Heat Exchanger (Fig. 6-19)	1
8	000-143-025	Screw, 3/8"-16UNC x 1.25" Lg. Hex Head Grd 8	2
9	000-174-021	Washer, 3/8" Lock	4
10	000-174-005	Washer, 3/8" Flat	4
11	000-174-068	Washer, Blower Feet	2
12	000-174-003	Washer, 1/4" Flat	5
13	000-174-019	Washer, 1/4" Lock	5
14	000-143-001	Screw, 1/4"-20UNC x 0.75" Lg. Hex Head	5
15	000-174-032	Washer, 3/8" Flat	6
16	000-174-057	Washer, 3/8" Lock	6
17	000-143-017	Screw, 3/8"-16UNC x 0.75" Lg. Hex Head Grd. 8	8
18	000-068-004	Hose, 3/4" I.D. Steam	1
19	000-068-015	Hose, 1/4" I.D. Bulk	1
20	000-068-723	Hose, 3/16" x 75" Lg. Teflon w/ JIC Ends	1
21	000-068-722	Hose, 3/8" x 46" Lg. Teflon w/ JIC Ends	1
22	000-068-660	Hose, 1/4" Fuel - Trident	1
23	000-068-085	Hose, 3/8" I.D. Hi-Temp	1
24	000-068-030	Hose, 5/32" I.D. Vacuum	1
25	000-033-003	Clamp, Size #4 Mini	2
26	000-068-030	Hose, 5/32" I.D. Vacuum	1
27	000-033-026	Clamp, Size #10 Hose	1
28	000-068-005	Hose, 5/16" I.D. Fuel Line - Bulk	1

CTS 450 *Hot Carbonating Truckmount System*

Figure 5-29 Dash Assembly CTS 450 Diesel - Front View
D-5867 Rev C

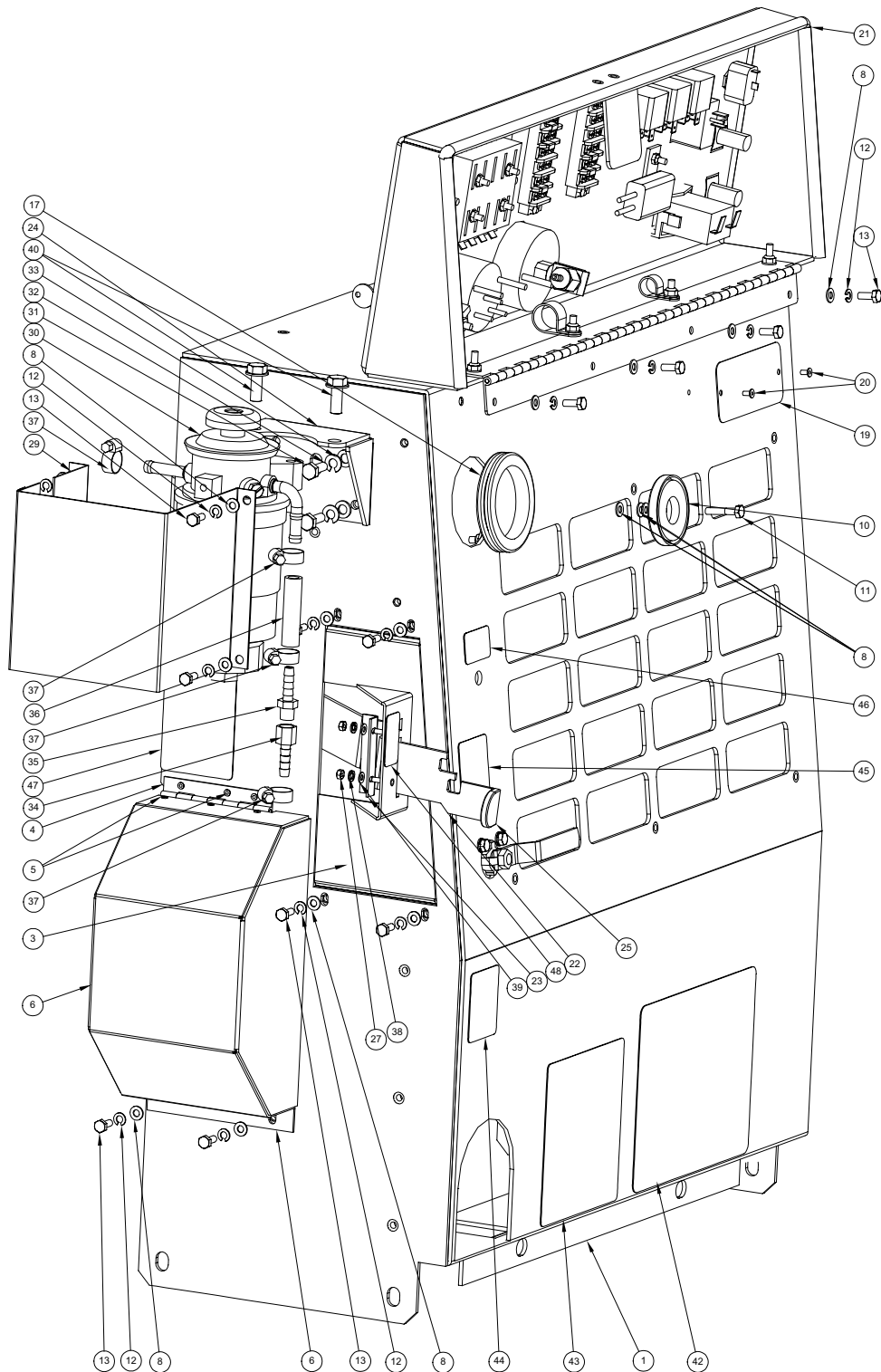
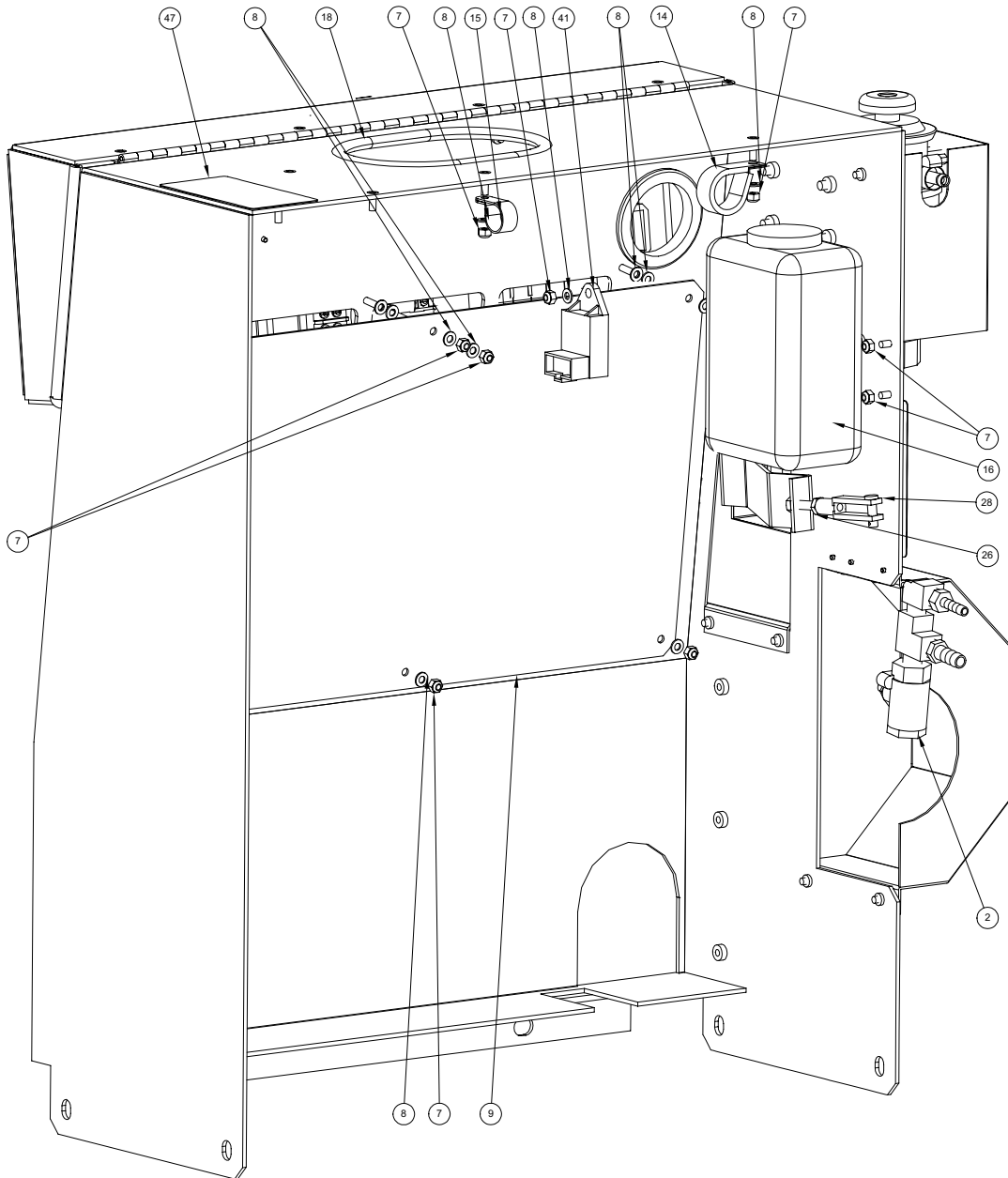

Figure 5-30 Dash Assembly CTS 450 Diesel - Rear View
D-5867 Rev C



Dash Assembly Parts List

Item	Part Number	Description	Qty
1	000-100-140	Panel, Dash - Weldment - CTS 450D	1
2	610-018-029	Assembly, Compressor Regulator - CTS 450 (Fig. 6-9)	1
3	000-015-220	Panel, Side - CTS 450 Diesel - Weldment	1
4	000-067-034	Hinge, Compressor Cover - CTS 450	1
5	000-140-001	Rivet, 1/8" x 1/4" Aluminum	6
6	000-108-123	Protector, Compressor Pulley - Weldment - CTS 450	1
7	000-094-034	Nut, #10-24UNC Nylock	12
8	000-174-001	Washer, #10 Flat	39
9	000-100-102	Panel, Perforated Grill	1
10	000-089-003	Magnet, Treadmaster	1
11	000-143-134	Screw, #10-24UNC x 1.00" Lg Hex Head	1
12	000-174-014	Washer, #10 Lock	14
13	000-143-126	Screw, #10-24UNC x 0.50" Lg. Hex Head	14
14	000-033-057	Clamp, 1" Cushion Loop	1
15	000-033-023	Clamp, 3/4" Nylon Hose	1
16	000-047-016	Tank, Coolant Overflow - Daihatsu Engine	1
17	000-060-003	Grommet, 2.50"	1
18	000-131-131	Trimlok, 3/8" x 1/8" Edge Trim	1
19	000-105-012	Plate, Machine Serial I.D.	1
20	000-140-015	Rivet, 1/8" x 1/4" Lg. Pop	2
21	610-020-031	Assembly, Brow - Dash - CTS 450D (Fig. 6-31)	1
22	000-015-222	Bracket, Throttle Handle	1
23	000-015-221	Bracket, Throttle Guide - CTS 450 Diesel	1
24	000-015-198	Weldment, Water Separator	1
25	000-041-082	Cover, Throttle Handle	1
26	000-094-112	Nut, 1/4"-28UNF Jam Hex Z/P	1
27	000-094-001	Nut, #6-32UNC Hex	2
28	000-085-010	Linkage, Clevis	1
29	000-108-049	Bracket, Water Separator Protector - CTS 450D	1
30	000-049-068	Fuel Separator	1

Dash Assembly Parts List

Item	Part Number	Description	Qty
31	000-143-001	Screw, 1/4"-20UNC x 0.75" Lg. Hex Head	4
32	000-174-019	Washer, 1/4" Lock	4
33	000-174-003	Washer, 1/4" Flat	4
34	000-052-109	Insert, #F24 (1/8" NPT x 1/4" Barb)	1
35	000-052-098	Insert, #25	1
36	000-068-005	Hose, 5/16" I.D. Fuel Line	1
37	000-033-003	Clamp, Size #4 Mini	4
38	000-174-043	Washer, #6 Lock	2
39	000-174-045	Washer, #6 Flat	2
40	- - -	Screw, 8.0mm x 20.0mm Lg. (Comes w/ Engine)	2
41	- - -	Timer, Glow Plug - Daihatsu 850D (Comes w/ Engine)	1
42	000-081-215	Label, Maintenance & Lubrication Schedule - CTS 450	1
43	000-081-215	Label, Engine Produces Toxic Gas - CTS 450	1
44	000-081-215	Label, Solution Valve - CTS 450	1
45	000-081-215	Label, Compressor Valve - CTS 450	1
46	000-081-215	Label, Choke - CTS 450	1
47	000-081-215	Label, Caution Rotating Equipment - CTS 450	2
48	000-081-215	Label, Throttle - CTS 450 Diesel	1

CTS 450 *Hot Carbonating Truckmount System*

Figure 5-31 Brow Assembly CTS 450 Diesel
D-5868 Rev B

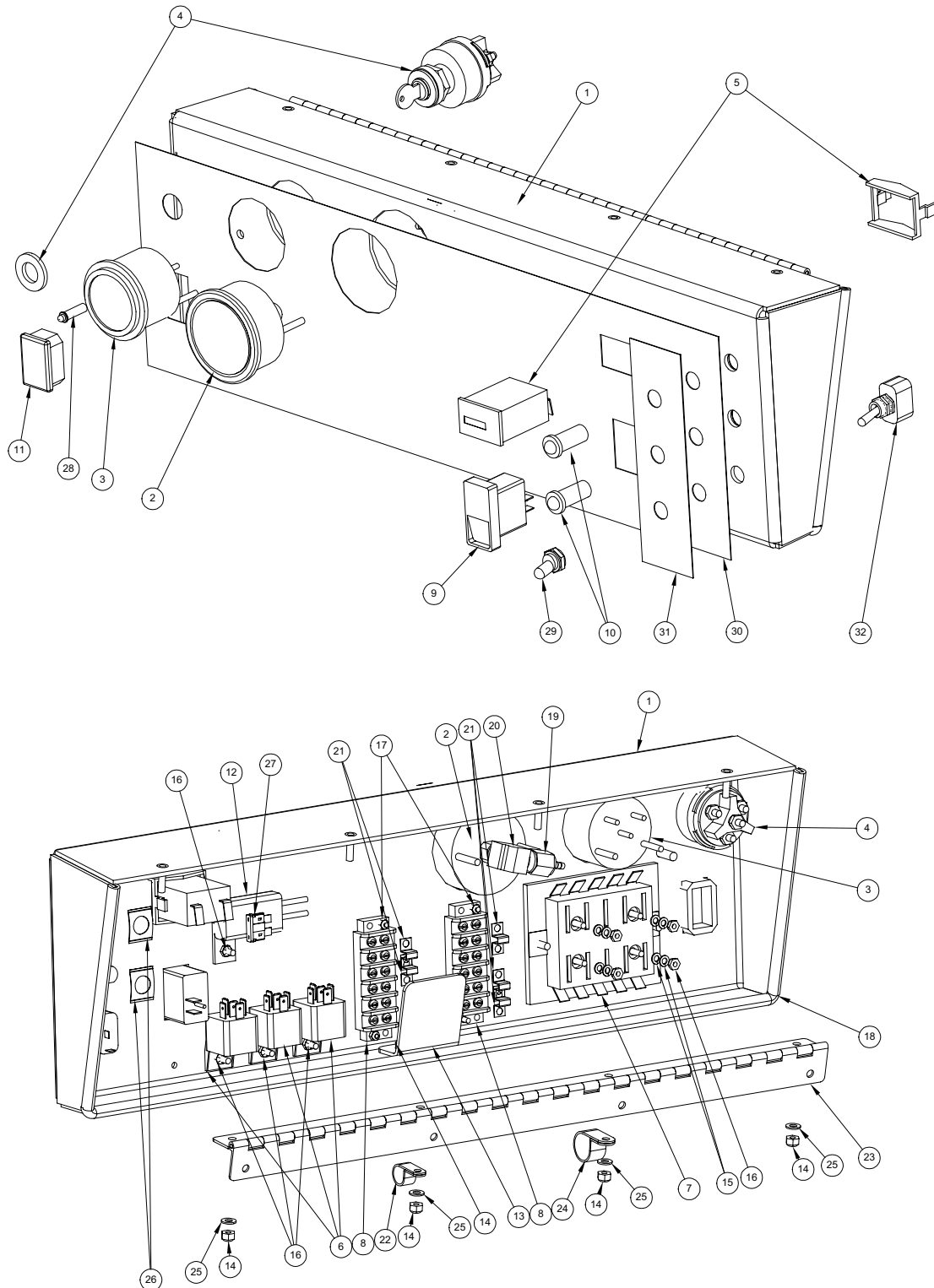

Brow Assembly Parts List

Item	Part Number	Description	Qty
1	000-100-136	Panel, Dash Brow - Weldment - CTS 450	1
2	000-074-025	Gauge, 0-30"Hg Vac. 2 1/2"	1
3	000-074-024	Gauge, Temperature	1
4	000-157-008	Switch, Ignition	1
5	000-074-018	Meter, Rectangular w/o Bezel	1
6	000-157-022	Switch, Relay	3
7	000-056-030	Diode Panel	1
8	000-012-002	Block, 6 Post Terminal	2
9	000-157-040	Switch, 20 AMP Rocker	1
10	000-084-015	Lamp, 12V 2W Round Red Indicator	2
11	000-106-065	Plug, 1" x 1-1/2" Plastic	1
12	000-056-006	Fuse Holder, Inline Weather Proof	1
13	000-015-839	Bracket, Magnet - Painted - CTS 450	1
14	000-094-034	Nut, #10-24UNC Nylock	6
15	000-174-025	Washer, #8 Lock	8
16	000-094-059	Nut, #8-32UNF Nylock	8
17	000-094-063	Nut, #6-32UNC Nylock	4
18	000-131-131	Trimlok, 3/8" x 1/8" Edge Trim	1
19	000-052-652	Insert, #F42 (1/4" FPT x 1/8" Barb)	1
20	000-052-085	Elbow, 1/4" NPT Street	1
21	000-037-011	Connector, "Jumper" Terminal Block	5
22	000-033-022	Clamp, 1/2" Nylon Hose	1
23	000-067-014	Hinge, Dash - CF 3.7/CTS 450	1
24	000-033-023	Clamp, 3/4" Nylon Hose	1
25	000-174-001	Washer, #10 Flat	4
26	000-033-049	Clamp, Indicator Lamp	2
27	000-056-011	Fuse, 30 AMP Plug In	1
28	000-084-011	Light, Red Led Indicator Mini	1
29	000-108-144	Protector, Chrome Switch	1
30	000-081-215	Label, Dash - CTS 450	1

Brow Assembly Parts List

Item	Part Number	Description	Qty
31	000-081-239	Label, Compressor Retro Kit - Dash - CTS 450	1
32	000-157-101	Switch, 15 AMP 115 Volt Toggle	1

Figure 5-32 Frame Assembly CTS 450 Diesel
D-5878 Rev A

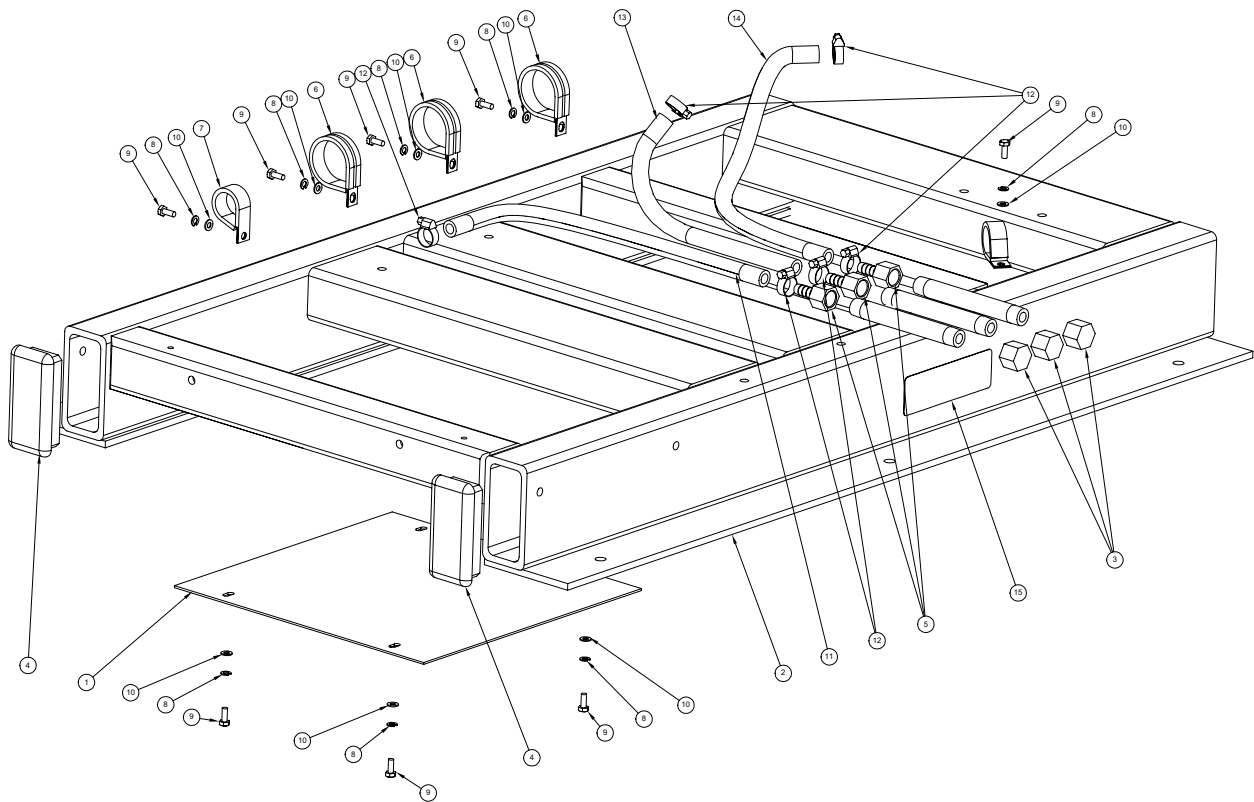

Frame Assembly Parts List

Item	Part Number	Description	Qty
1	000-108-124	Protector, Muffler Heat Shield - CTS 450	1
2	000-055-159	Frame, Weldment - CTS 450	1
3	000-027-008	Cap, 3/8" FPT	3
4	000-027-034	Cap, Frame End - Modified - Maxx/CTS 450	2
5	000-052-488	Insert, #F66 (3/8" NPT x 3/8" Hose Barb)	3
6	000-033-050	Clamp, 1-3/4" Cushion Loop	3
7	000-033-057	Clamp, 1" Cushion Loop	2
8	000-174-014	Washer, #10 Lock	9
9	000-143-126	Screw, #10-24UNC x 0.50" Lg. Hex Head	9
10	000-174-001	Washer, #10 Flat	9
11	000-068-085	Hose, 3/8" I.D. Hi-Temp	1
12	000-033-005	Clamp, Size #5 Hose	6
13	000-068-085	Hose, 3/8" I.D. Hi-Temp	1
14	000-068-085	Hose, 3/8" I.D. Hi-Temp	1
15	000-081-215	Label, Oil Drain Plugs - CTS 450	1

CTS 450 *Hot Carbonating Truckmount System*

Figure 5-33 Engine Assembly CTS 450 Diesel - Right View
D-5866 Rev C

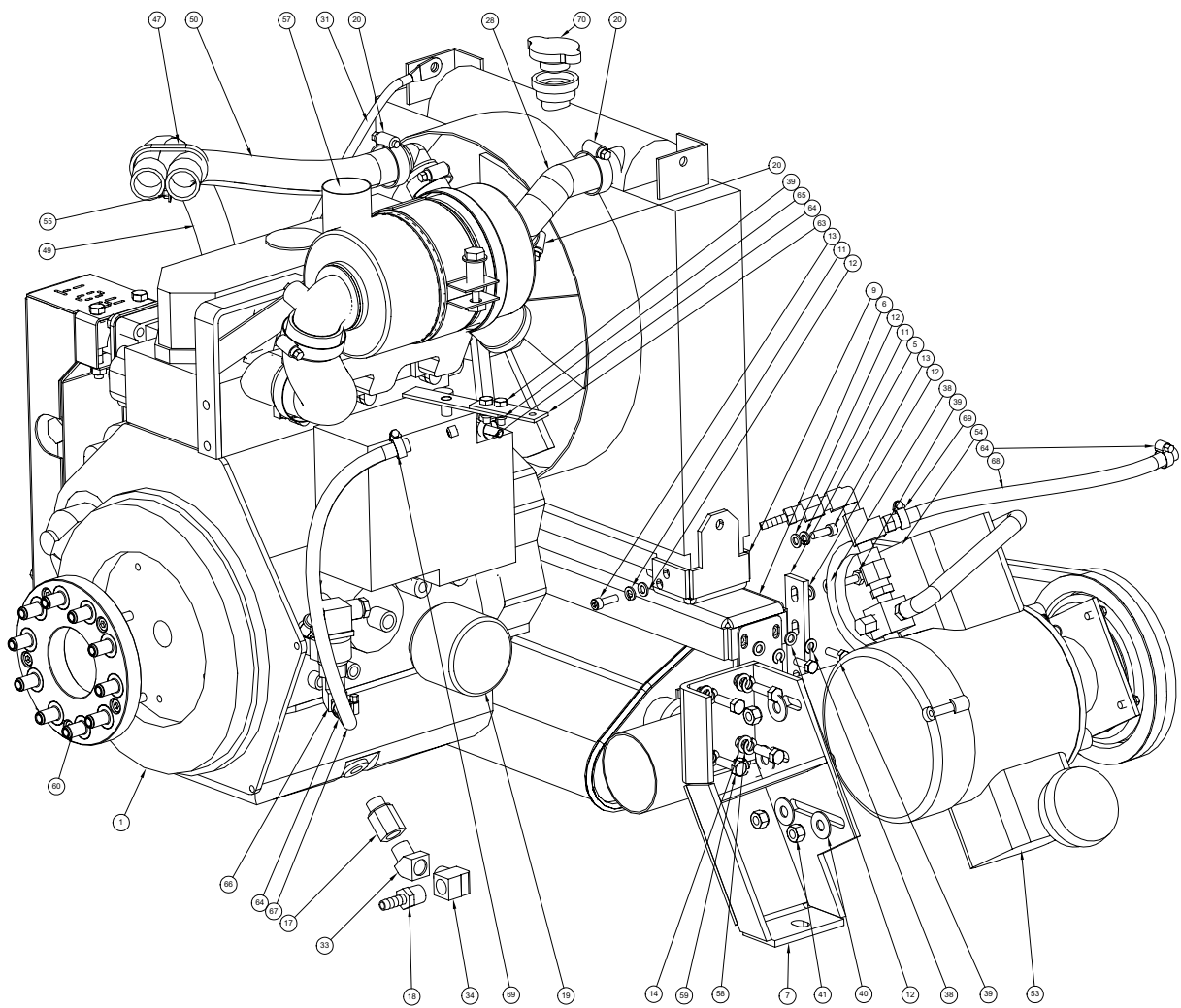
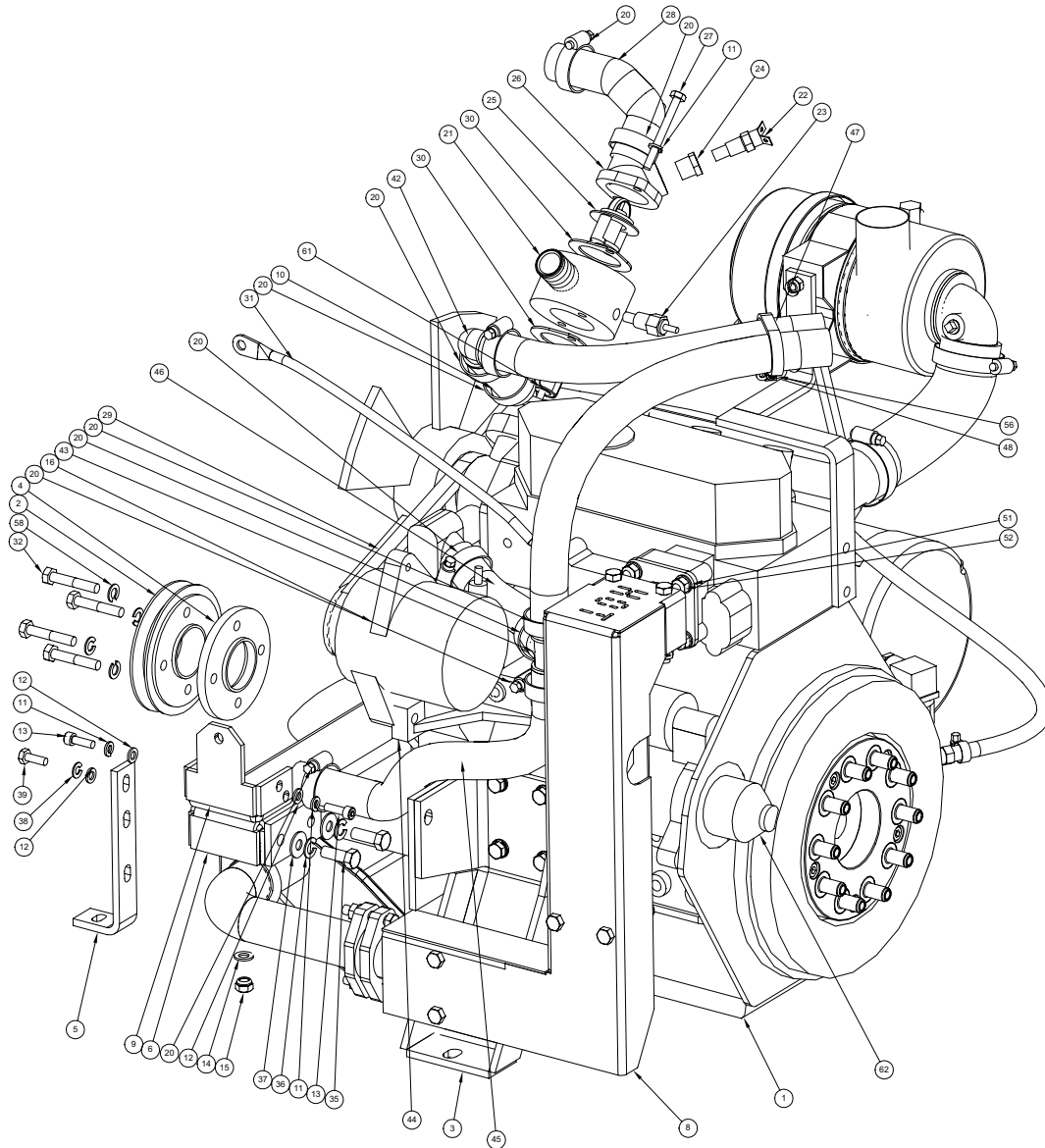

Figure 5-34 Engine Assembly CTS 450 Diesel - Left View
D-5866 Rev C



Engine Assembly CTS 450 Diesel Parts List

Item	Part Number	Description	Qty
1	000-047-017	Engine, Daihatsu 850 Diesel	1
2	000-109-078	Pulley, CAT Pump Drive	1
3	000-015-731	Bracket, Right Front Foot - Daihatsu	1
4	000-154-126	Spacer, Daihatsu Crank Shaft - CTS 450	1
5	000-015-872	Bracket, Radiator Mounting - CTS 450	2
6	000-015-831	Bracket, Radiator Channel	1
7	000-015-858	Bracket, Left Front Engine Mounting	1
8	610-003-029	Assembly, Exhaust - CTS 450 (Fig. 6-12)	1
9	000-015-737	Bracket, Radiator Mounting	2
10	000-068-250	Hose, 1" Green Stripe	1
11	000-174-017	Washer, 1/4" Lock	6
12	000-174-003	Washer, 1/4" Flat	8
13	000-143-077	Screw, 6mm x 20mm Lg. Socket Head	4
14	000-174-049	Washer, 5/16" Flat	10
15	000-094-038	Nut, 5/16"-18UNC Nylock	2
16	000-004-001	Alternator, Daihatsu 700G & 950G	1
17	000-052-058	Adapter, 3/8" FPT x 16mm Male Engine Oil Drain	1
18	000-052-104	Insert, #66 (3/8" NPT x 3/8" Barb)	1
19	000-049-014	Filter, 16HP Oil - All B & S	1
20	000-033-020	Clamp, Size #16 Hose	10
21	000-001-033	Adapter, Thermostat Housing	1
22	000-149-505	Sensor, 240° F Daihatsu Engine	1
23	000-149-039	Sender, Temperature	1
24	000-052-061	Bushing, 3/8" NPT x 1/4" FPT	1
25	000-149-023	Thermostat, 195° F Engine	1
26	000-047-016	Thermostat Housing - Daihatsu Engine	1
27	000-143-220	Screw, 6mm x 65mm Lg. Hex Head	2
28	000-068-500	Hose, Upper Radiator Daihatsu Engine	1
29	000-010-027	Belt, CTS 450 Alternator Replacement	1
30	000-057-050	Gasket, Thermostat Housing Daihatsu Engine	2

Engine Assembly CTS 450 Diesel Parts List

Item	Part Number	Description	Qty
31	000-047-016	Bracket, Radiator Upper Support - Right - Raw	1
32	000-143-184	Screw, 8mm x 45mm Lg. Hex Head Grd. 10.9	4
33	000-052-083	Elbow, 3/8" NPT Street x 45°	1
34	000-052-086	Elbow, 3/8" NPT Street	1
35	000-143-018	Screw, 3/8"-16UNC x 1.00" Lg. Grade 8	2
36	000-174-057	Washer, 3/8" Lock	2
37	000-174-032	Washer, 3/8" Flat	2
38	000-174-019	Washer, 1/4" Lock	4
39	000-143-001	Screw, 1/4"-20UNC x 0.75" Lg. Hex Head	6
40	000-174-005	Washer, 3/8" Flat	4
41	000-094-100	Nut, 3/8"-16UNC Hex Nylock	4
42	000-052-091	Elbow, 1" Barb x 1" Barb (For Radiator Hose)	1
43	000-052-648	Tee, 1" Barb x 1" Barb x 1" Barb	1
44	000-047-016	Bracket, Alternator Mounting - Lower - Daihatsu 700G/	1
45	000-068-032	Hose, 1" I.D. w/90° Preform Lower Rad.	1
46	000-068-500	Hose, Upper Radiator - Daihatsu Engine	1
47	000-033-067	Clamp, 2" Cushion Loop	1
48	000-143-126	Screw, #10-24UNC x 0.50" Lg. Hex Head	1
49	000-068-250	Hose, 1" I.D. Green Stripe	1
50	000-068-250	Hose, 1" I.D. Green Stripe	1
51	000-174-069	Washer, 5/16" Inconel Belleville, Diverter Valve	4
52	000-094-043	Nut, 8mm Hex	4
53	610-007-029	Assembly, Air Compressor - CTS 450 (Fig. 6-14)	1
54	000-010-124	Belt, Air Compressor - CTS 450	1
55	000-174-001	Washer, #10 Flat	1
56	000-094-034	Nut, #10-24UNC Nylock	1
57	610-003-031	Assembly, Air Cleaner - CTS 450 Diesel (Fig. 6-35)	1
58	000-174-018	Washer, 5/16" Lock	12
59	000-143-187	Screw, 8mm x 25mm Lg. Grade. 10.9 Hex Head	8
60	000-039-055	Coupler, C-Face 10 Pin CTS 450 Diesel	1

Engine Assembly CTS 450 Diesel Parts List

Item	Part Number	Description	Qty
61	000-149-052	Thermostat, Daihatsu Engine Coolant	1
62	000-091-023	Starter, Daihatsu 700G Engine	1
63	000-015-223	Bracket, Throttle Lever	1
64	000-033-003	Clamp, Size #4 Mini	3
65	000-094-009	Nut, 1/4"-20UNC Hex Nylock	2
66	610-003-029	Assembly, Compressor Check Valve (Fig. 6-15)	1
67	000-068-131	Hose, 1/4" I.D. Silicone - Bulk	1
68	000-068-131	Hose, 1/4" I.D. Silicone - Bulk	1
69	000-033-005	Clamp, Size #5 Hose	2
70	000-027-114	Cap, Radiator 3Lc Engine - Daihatsu	1

Figure 5-35 Air Cleaner Assembly CTS 450 Diesel
C-5879 Rev -

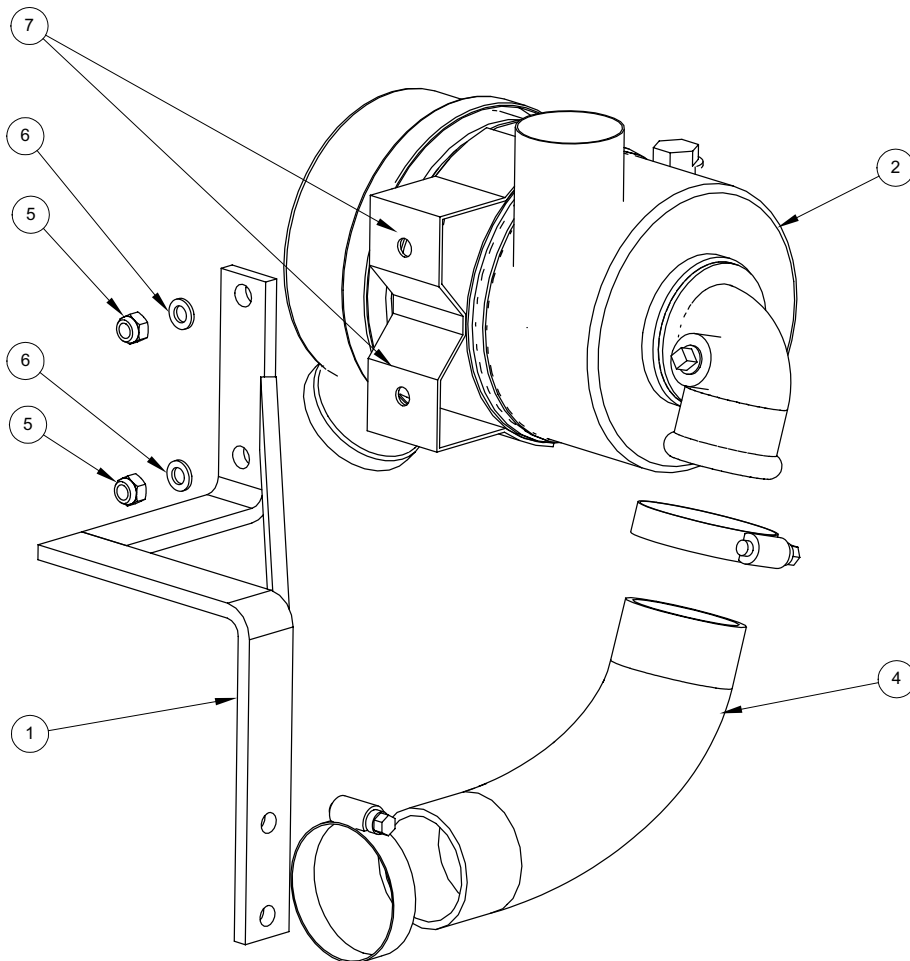

Air Cleaner CTS 450 Diesel Assembly Parts List

Item	Part Number	Description	Qty
1	000-015-844	Bracket, Air Cleaner Mounting - CTS 450	1
2	000-047-016	Air Cleaner - Daihatsu Engine	1
3	000-033-007	Clamp, #28 Hose	2
4	000-068-733	Hose, Air Cleaner To Carb.	1
5	000-094-009	Nut, 1/4"-20UNC Hex Nylock	2
6	000-174-003	Washer, 1/4" Flat	2
7	000-143-001	Screw, 1/4"-20UNC x 0.75" Lg. Hex Head	2

CTS 450 *Hot Carbonating Truckmount System*

Figure 5-36 Blower Assembly CTS 450 Diesel
D-6578 Rev -

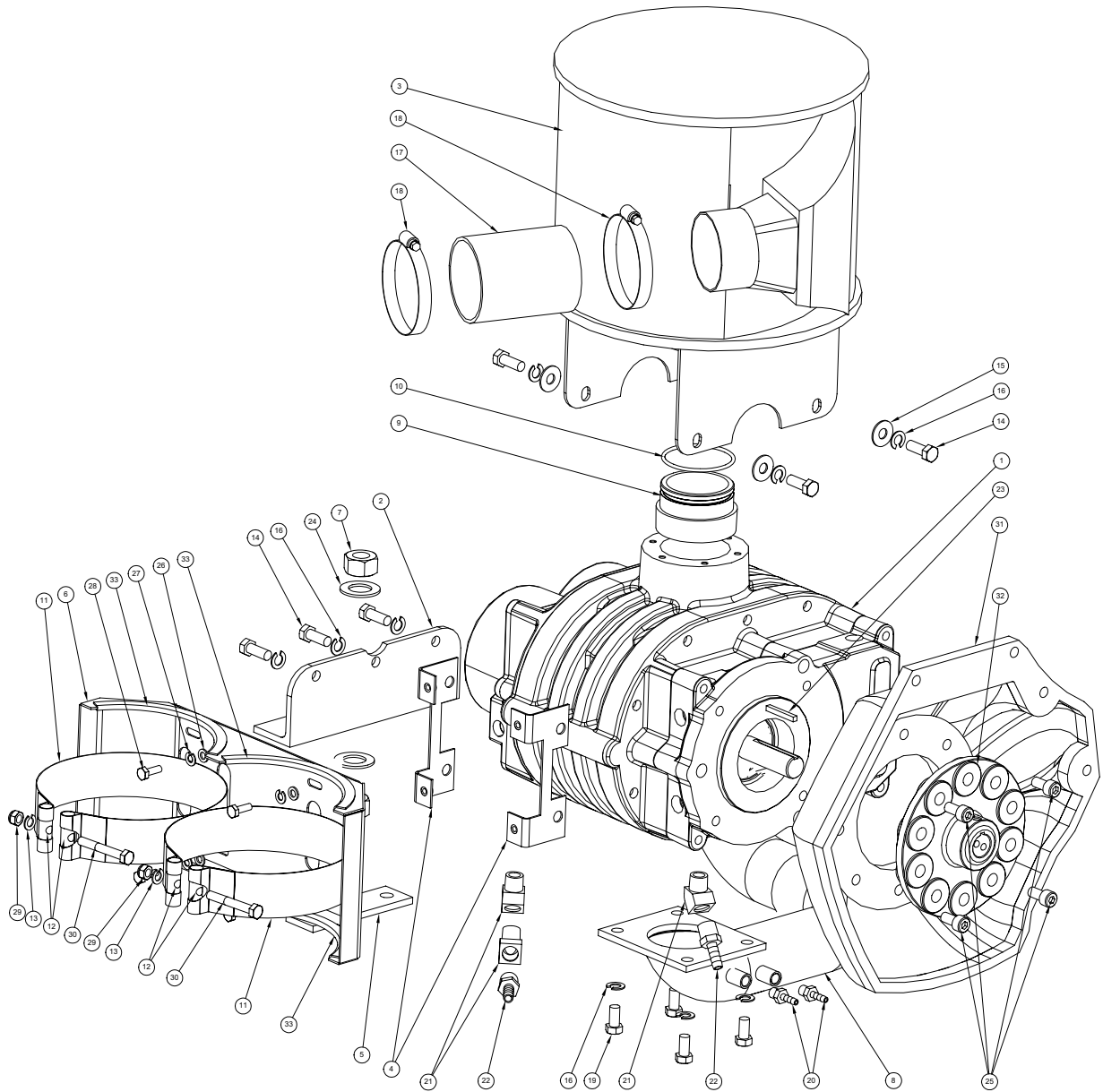

Engine Assembly CTS 450 Diesel Parts List

Item	Part Number	Description	Qty
1	000-111-165	Blower, 4005 C-Face	1
2	000-015-827	Bracket, Blower Foot - CTS 450	1
3	000-093-084	Silencer, 3" Blower - CTS 450	1
4	000-015-840	Plate, Saddle Mounting - After Burner - CTS 450	2
5	000-015-829	Bracket, Blower Foot Adjustment - CTS 450	1
6	000-015-830	Bracket, Dual After Burner Saddle - Weldment	1
7	000-094-080	Nut, 3/4"-10UNC Hex	2
8	000-001-113	Adapter, Blower Inlet - CTS 450	1
9	000-001-024	Adapter, Blower To Silencer	1
10	000-097-029	O-Ring, Blower To Silencer (2 3/4" ID x 2 1/2" OD x 1/8	1
11	000-033-123	Clamp, After Burner Mount - Boxxer 421	2
12	000-141-033	Rod, Heat Exchanger Strap - Retainer	4
13	000-174-018	Washer, 5/16" Lock	2
14	000-143-018	Screw, 3/8"-16UNC x 1.00" Lg. Grade 8	7
15	000-174-005	Washer, 3/8" Flat	4
16	000-174-021	Washer, 3/8" Lock	11
17	000-068-398	Hose, 3" Blue Silicone x 3 Ply	1
18	000-033-013	Clamp, Size #48 Hose	2
19	000-143-017	Screw, 3/8"-16UNC x 0.75" Lg. Hex Head Grd. 8	4
20	000-052-293	Insert, #23 (1/8" NPT x 3/16" Barb)	2
21	000-052-083	Elbow, 3/8" NPT Street x 45°	3
22	000-052-104	Insert, #66 (3/8" NPT x 3/8" Barb)	2
23	000-077-011	Key, 3/16" x 1.50" Lg. Class 2 Fit	1
24	000-174-028	Washer, 7/8" I.D. x 1.50" O.D. x 0.090" Thk.	2
25	00-143-094-	Screw, 3/8"-16UNC x 0.75" Lg. Socket Head	4
26	000-174-003	Washer, 1/4" Flat	4
27	000-174-019	Washer, 1/4" Lock	4
28	000-143-001	Screw, 1/4"-20UNC x 0.75" Lg. Hex Head	4
29	000-094-038	Nut, 5/16"-18UNC Nylock	2
30	000-143-092	Screw, 5/16"-18UNC x 2.25" Lg. Hex Head	2

Engine Assembly CTS 450 Diesel Parts List

Item	Part Number	Description	Qty
31	000-042-008	Housing, Bell - CTS 450	1
32	000-039-055	Coupler, C-Face 10 Pin CTS 450 Diesel	1
33	000-131-027	Trimlok, Crossfire Brow	4

CTS 450 Hot Carbonating Truckmount System

Figure 6-1 Solution Flow Diagram
D-5860 Rev C

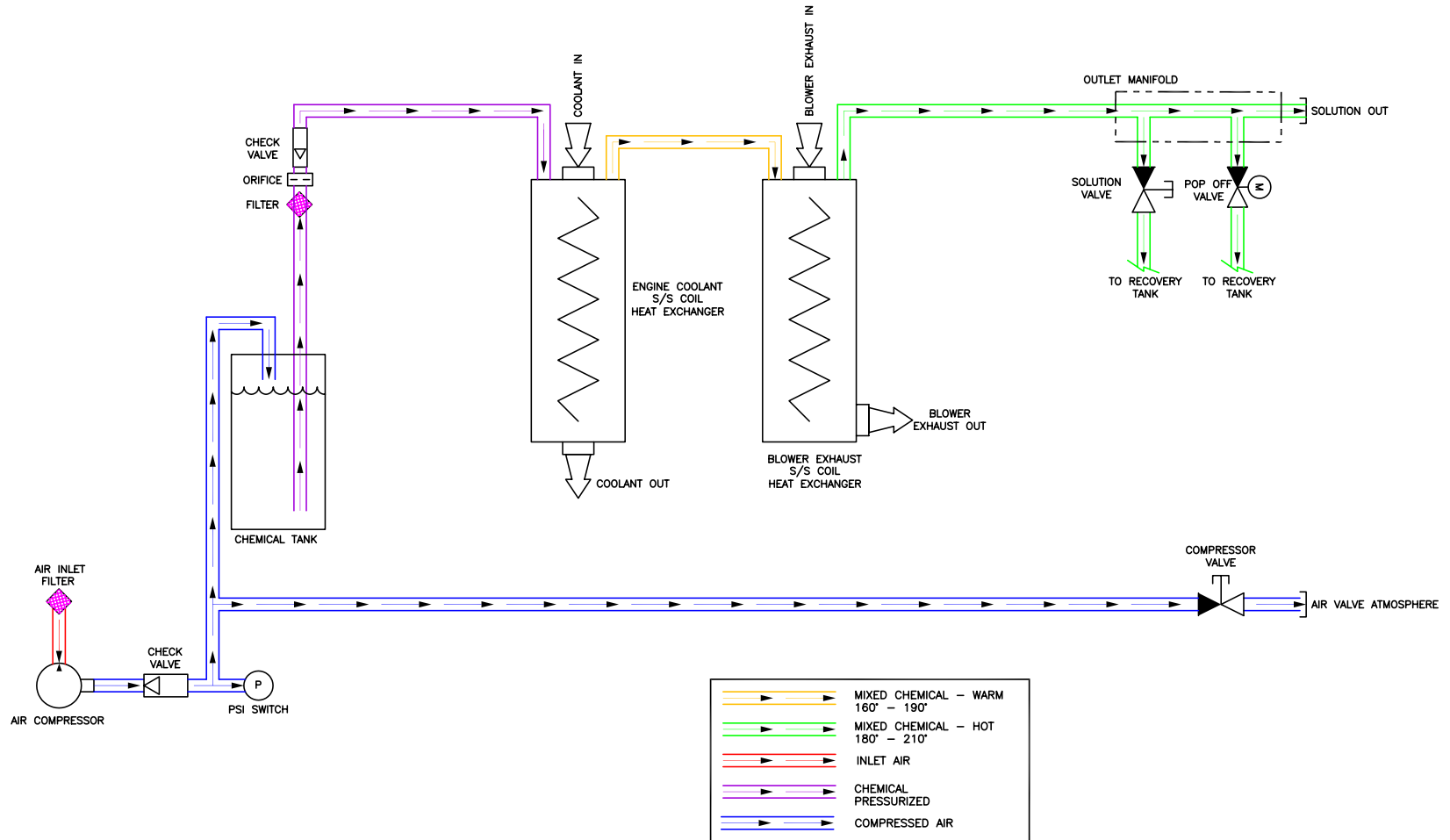

CTS 450 Hot Carbonating Truckmount System

Figure 6-1 Solution Flow Diagram

D-5860 Rev C

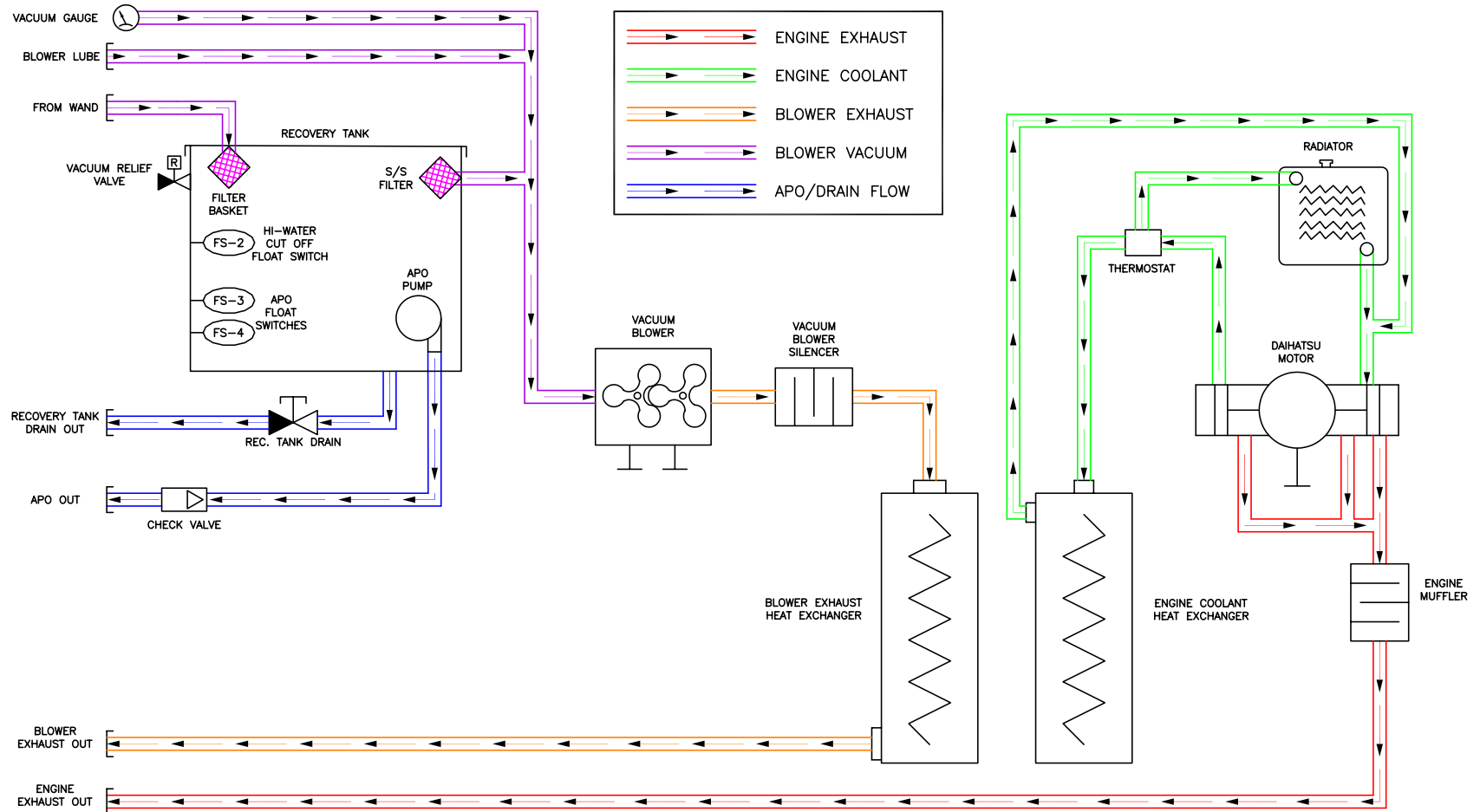

7-1 Wiring Diagram - CTS 450 Gas Engine

D-5503 Sht 2, Rev P

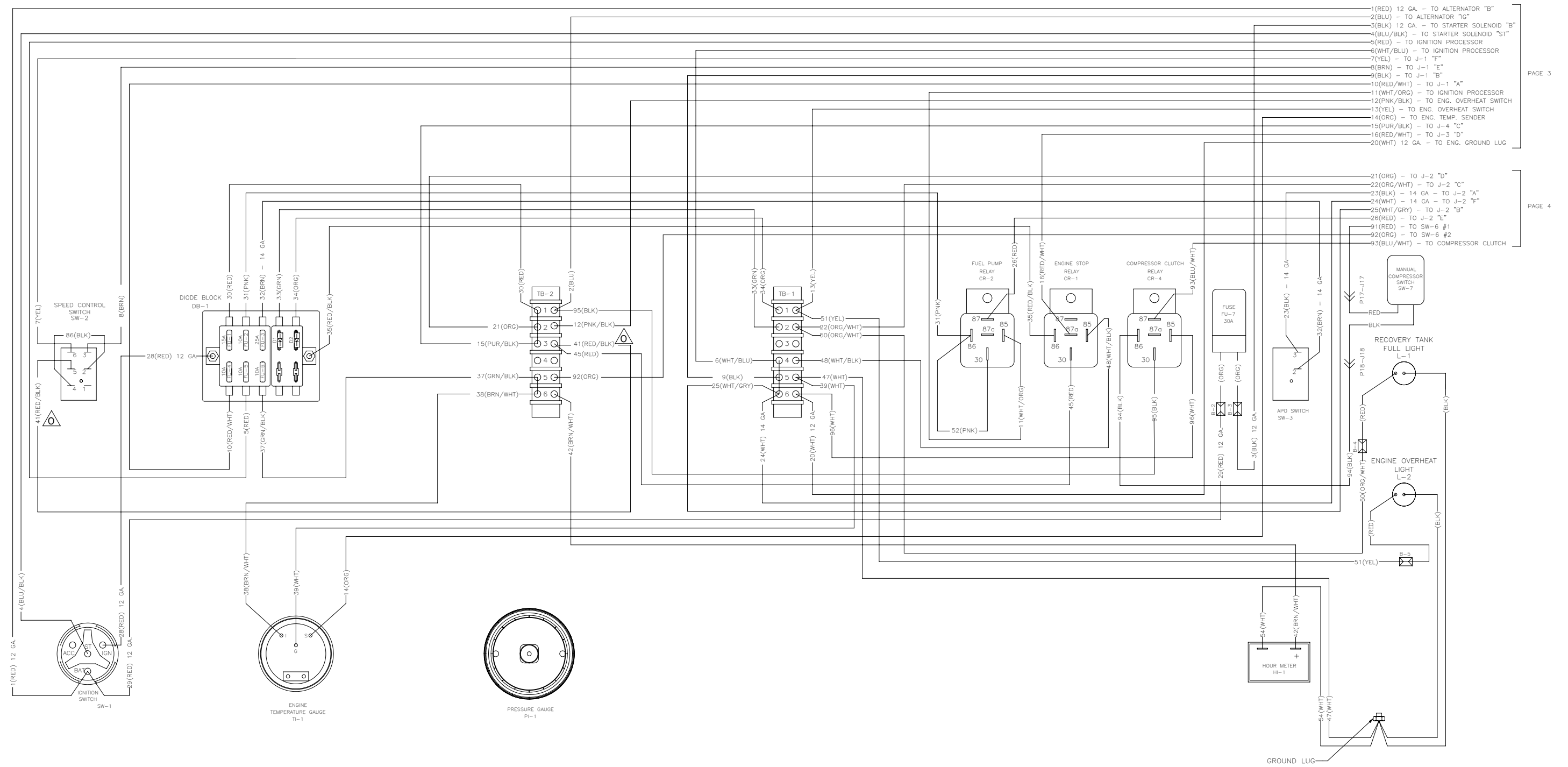

PAGE 3

PAGE 4

7-2 Wiring Diagram - CTS 450 Gas Engine

D-5503 Sht 3, Rev P

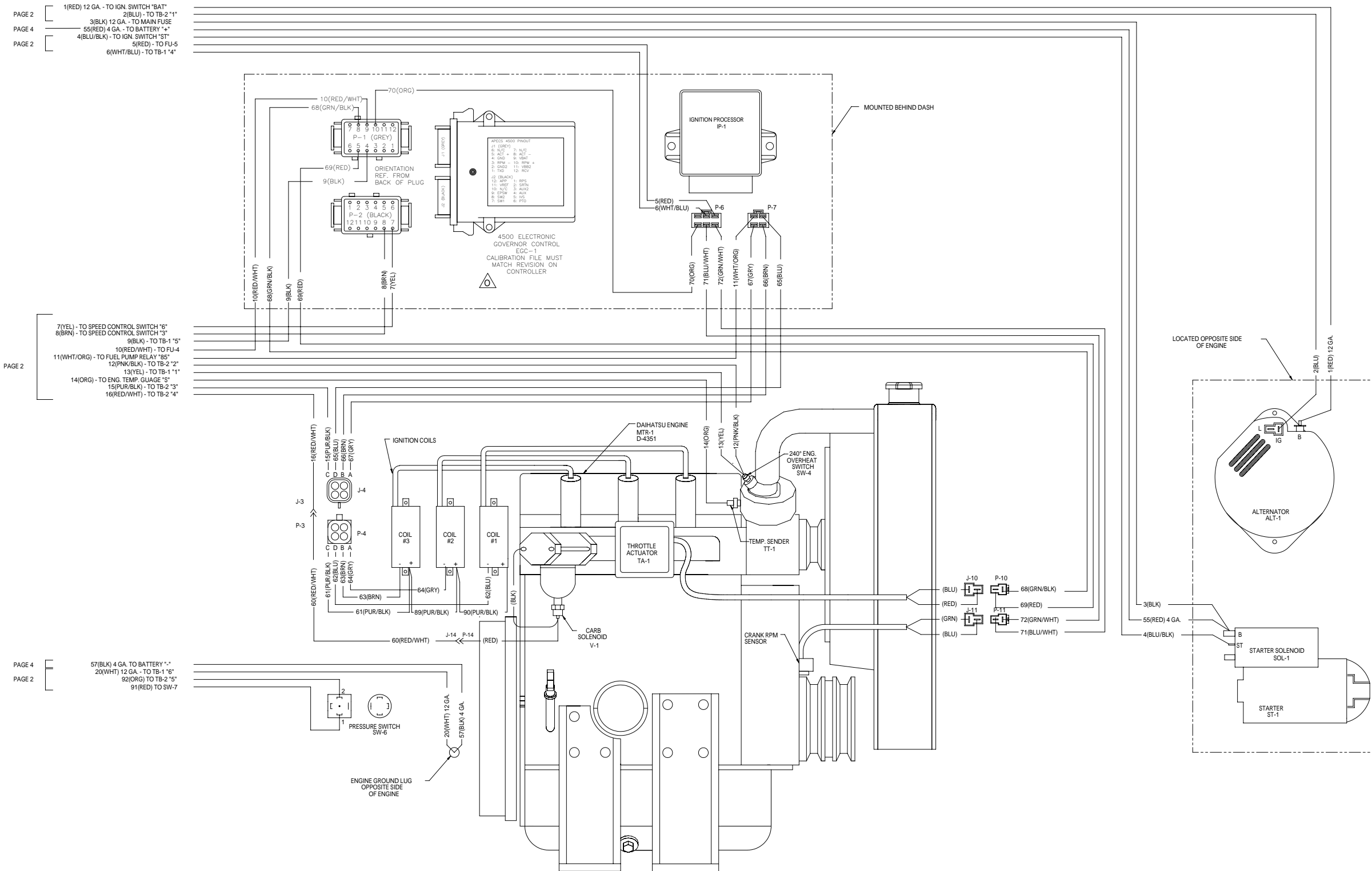

7-3 Wiring Diagram - CTS 450 Gas Engine

D-5503 Sht 4, Rev P

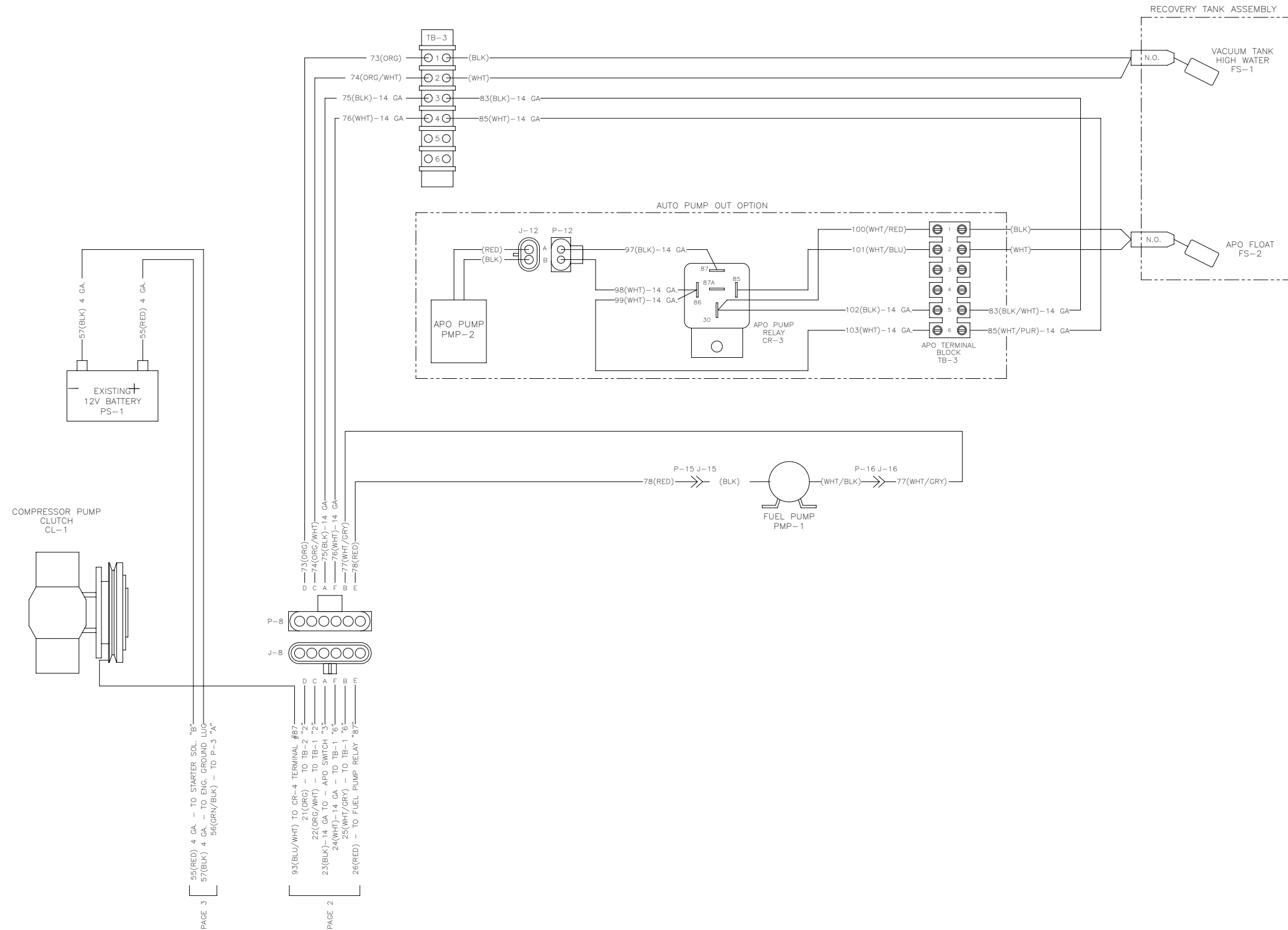

7-4 Wiring Diagram - CTS 450 Diesel Engine

D-5638 Sht 1, Rev J

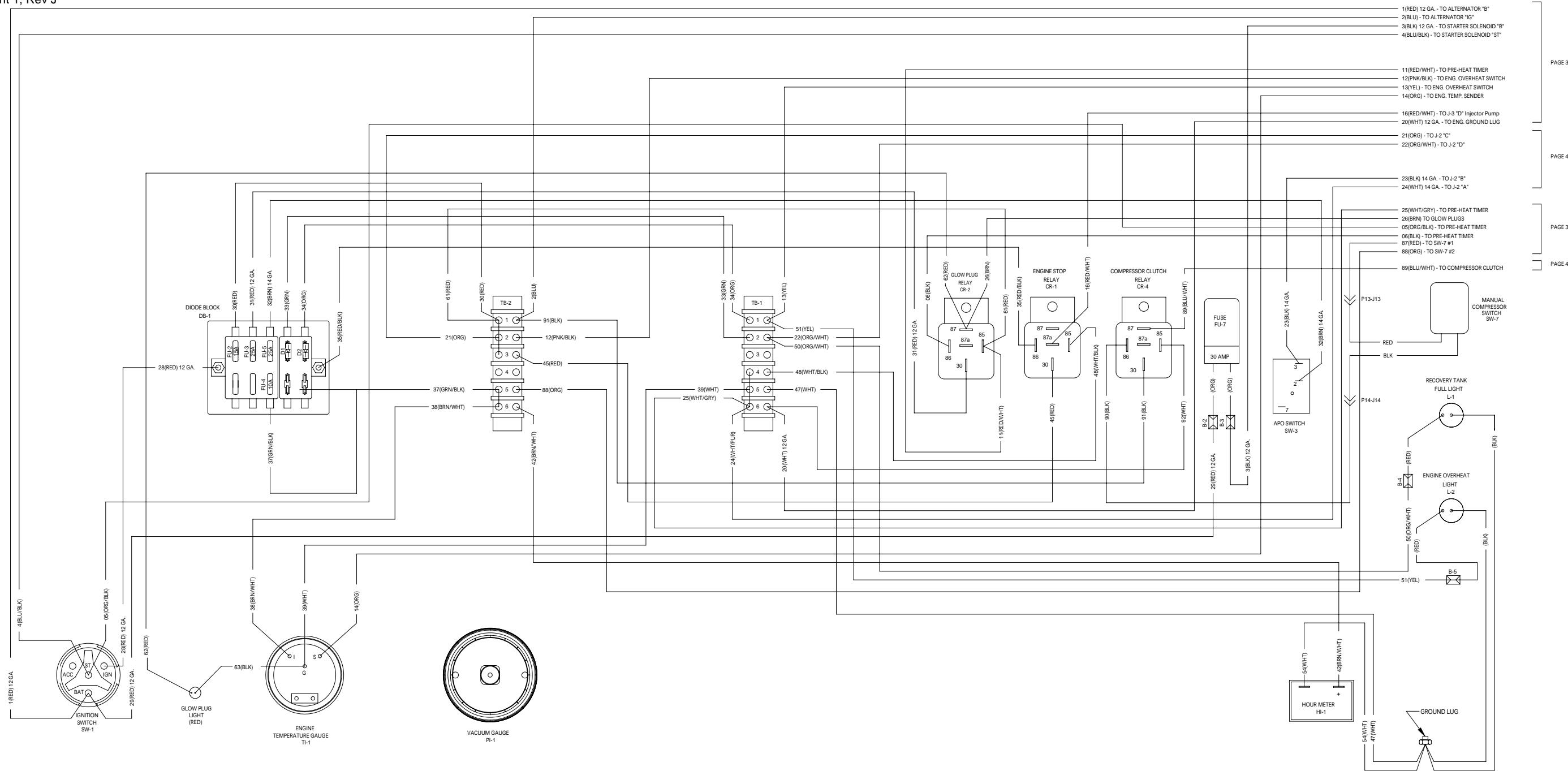

7-5 Wiring Diagram - CTS 450 Diesel Engine

D-5638 Sht 2, Rev J

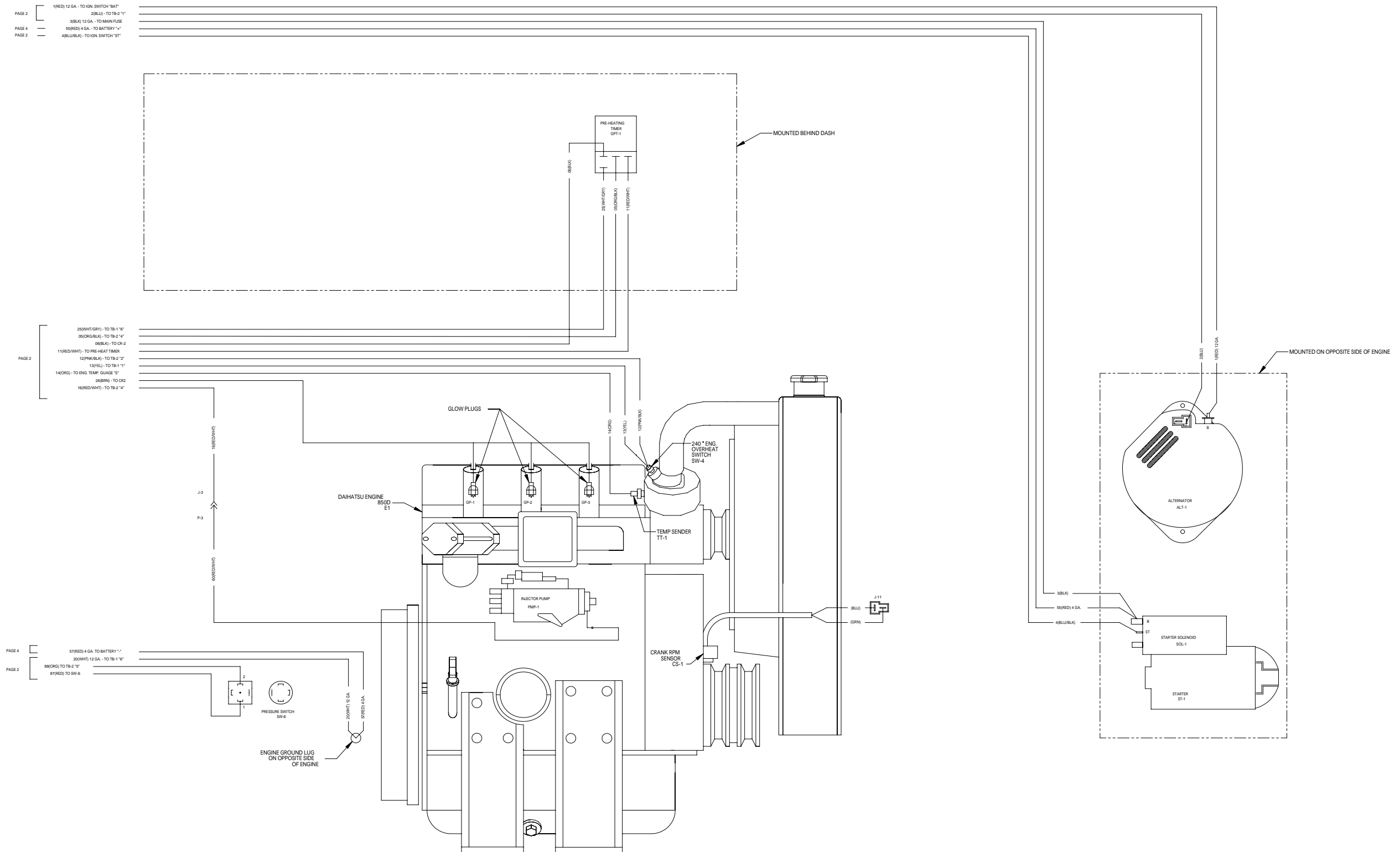

7-6 Wiring Diagram - CTS 450 Diesel Engine

D-5638 Sht 3, Rev J

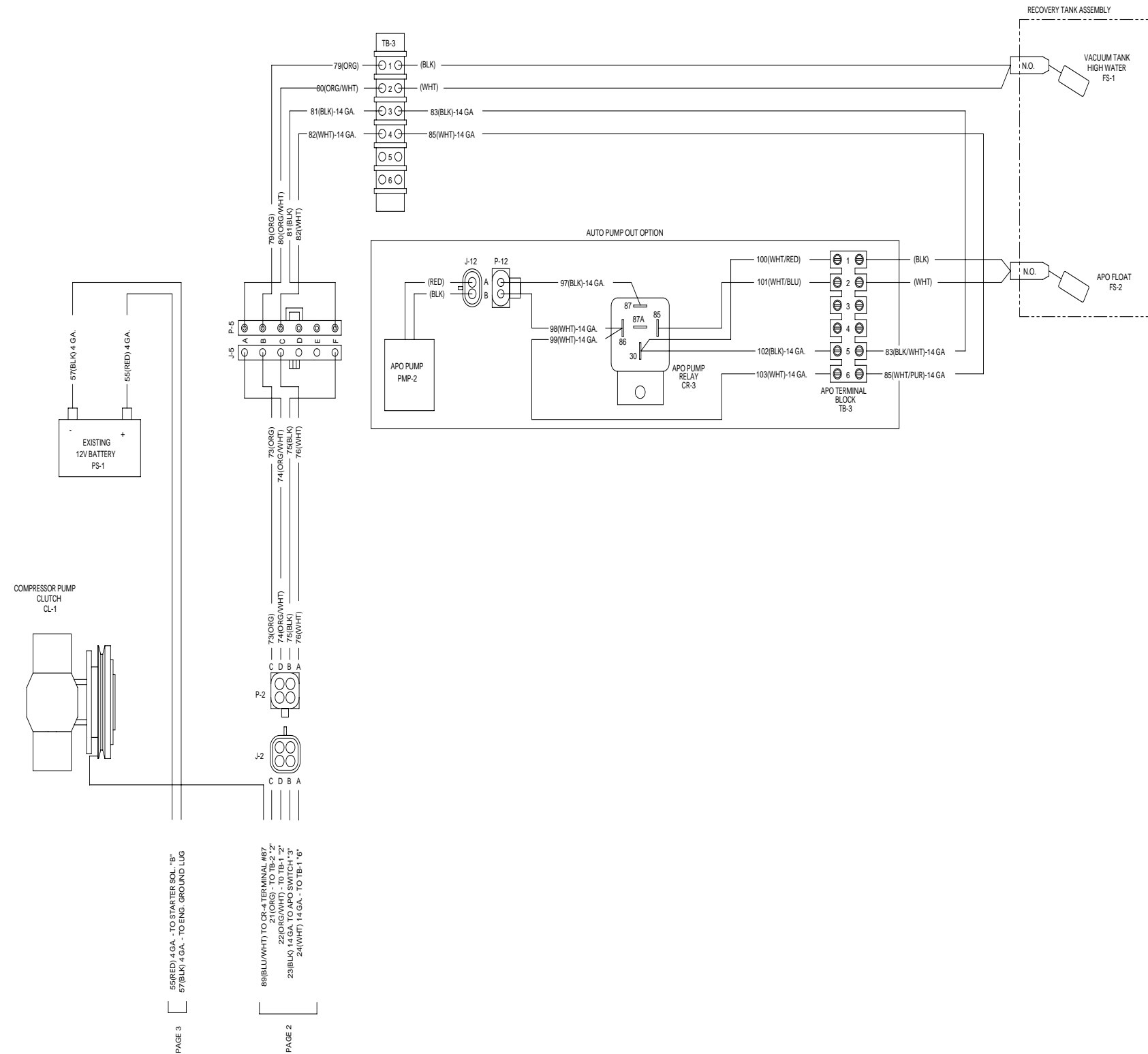

7-7 Electrical Schematic - CTS 450

D-5502 Rev H

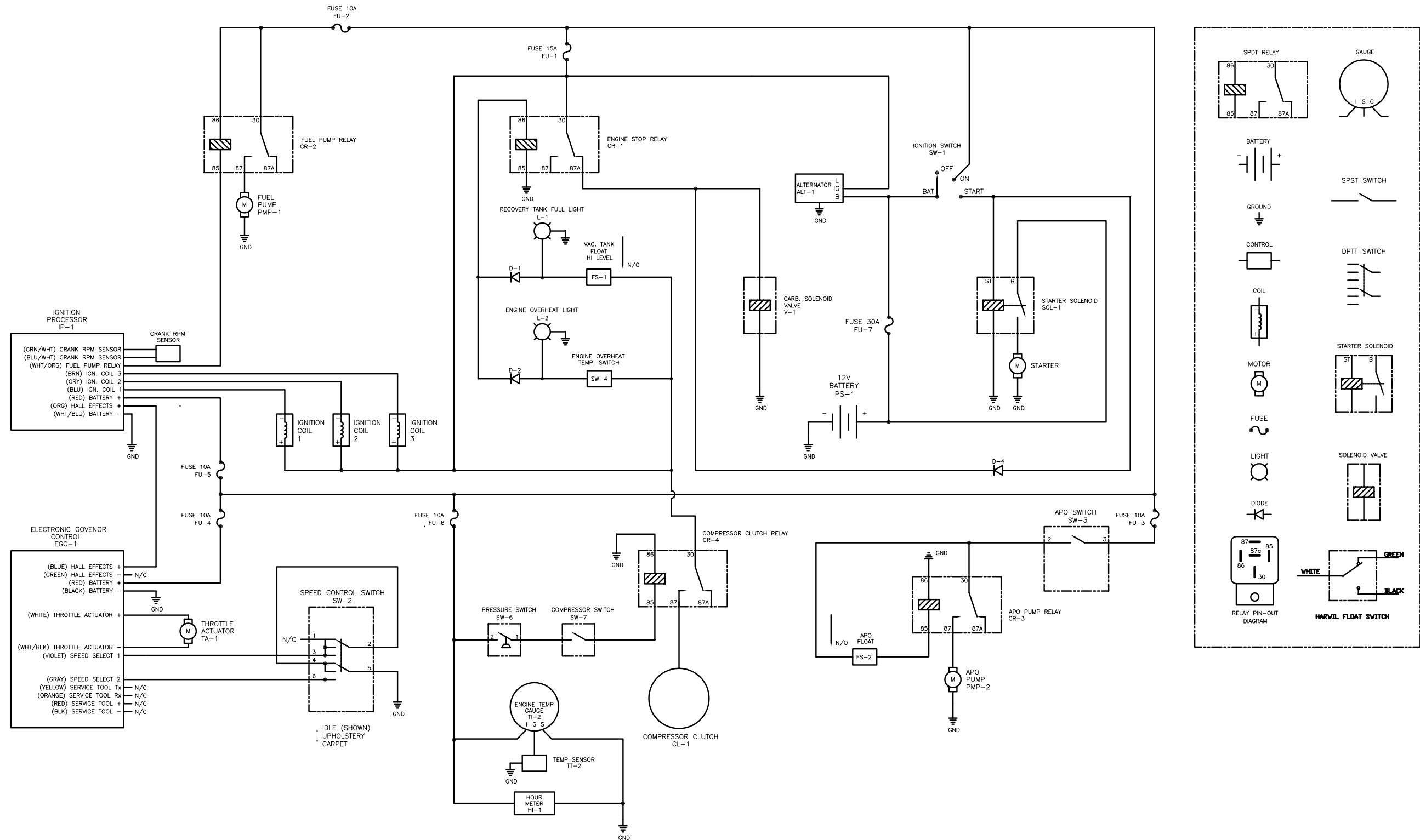

Warranty Information

To avoid misunderstandings which might occur between machine owners and manufacturer, we are listing causes of component failure that specifically voids warranty coverage. Such causes as listed below shall constitute **abuse** or **neglect**.

Blower:

- Failure to lubricate impellers daily with an oil-based lubricant.
- Failure to properly maintain oil levels in the blower.
- Failure to properly grease blower.
- Failure to use the correct oil grade and viscosity as recommended in the blower manual.
- Failure to properly maintain blower safe guard systems such as waste tank filter screen, vacuum safety relief valve and waste tank automatic shut-off system.
- Allowing foam to pass through blower.

Vacuum Tank:

- Failure to properly maintain filtering devices.
- Failure to clean tank as recommended by manufacturer.
- Failure to maintain vacuum safety release in tank.
- Use of improper chemicals.

Solution System:

- Use of improper chemical
- Operating machine without proper solution filter screen.
- Failure to protect against freezing.

Vacuum and Solution Hose:

- Failure to protect hoses against freezing.
- Failure to protect hoses against burns from engine and blower exhaust.
- Damage to hoses from being run over by vehicles.
- Kinking or cracking from failure to store or unroll hoses correctly.
- Normal wear and tear from everyday use.

Water Heating System:

- Failure to protect against freezing.

Limited Warranty Plan

HydraMaster warrants all machines of its manufacture to be free from defects in material and workmanship if properly installed, maintained, and operated under normal conditions with competent supervision. No person, agent, representative or dealer is authorized to give any warranties on behalf of HydraMaster, nor to assume for HydraMaster any other liability in connection with any HydraMaster products. This warranty shall extend to the original purchaser of said equipment for the periods listed below from date of installation. If repairs or replacements are made by the Purchaser without HydraMaster written consent, HydraMaster warranty shall cease to be in effect.

Machinery, equipment and accessories furnished by HydraMaster, but manufactured by others, are warranted only to the extent of the original manufacturer's warranty to HydraMaster. Warranties on equipment purchased or used outside of the United States may not carry the same warranty, as per the policy of the individual component manufacturers.

HydraMaster agrees, at its option, to repair at the point of shipment, or to replace without charge, any parts or parts of products of HydraMaster's manufacture, which within the specified warranty period shall be proved to HydraMaster's satisfaction to have been defective when shipped, provided the purchaser promptly notifies HydraMaster, in writing, of such alleged defect. HydraMaster will pay all freight and transportation charges within the United States, via normal ground shipping means, for replacement of parts covered under this warranty.

This warranty covers parts, as specified, and does not cover labor which may be necessary in completing repairs. HydraMaster's liability to Purchaser, whether in contract or in tort arising out of warranties, representation, instructions, or defects from any cause shall be limited to repairing or replacing the defective part or parts. To qualify for warranty coverage, defective parts must be returned to HydraMaster within 30 days. No warranty liability whatsoever shall attach to HydraMaster unless and until HydraMaster has received payment in full for the warranted machine or part.

Except as stated in this section and in the proceeding section and except as to title, there are no guarantees or warranties of merchantability, fitness, performance or otherwise, express, implied or statutory, and HydraMaster shall have no liability for consequential, incidental or other damages howsoever caused.

All components not specifically referenced in the schedule below are covered under this warranty for a period of one (1) year, excepting those parts which are considered, by HydraMaster, to be expendable in normal use, including but not limited to paint, labels and other cosmetic parts or features.