

RX-20 / CMX-20

<i>Table of Contents</i>	<i>Page</i>
Introduction	1
Machine Specifications	2
Assembly Instructions	3
Operation	4
Cleaning Information	6
Machine Maintenance	8
Machine Parts	11
Repair	21
Troubleshooting	22
Limited Warranty Plan	24

Machine Serial Number _____

Copyright © 1998
HYDRAMASTER® Corporation
Mukilteo, Washington

182-006

No part of this manual may be reproduced or used in any form or by any means (i.e. graphic, electronic, photocopying or electronic retrieval systems) without the express written permission of the HYDRAMASTER® Corporation. All rights reserved.

Revised September 10, 1998

Congratulations!☺!☺

You now own a piece of equipment that incorporates the latest in carpet cleaning technology. The RX-20's features will almost certainly increase the productivity of you and your business, while decreasing the fatigue factor that may have prevented you from going after some of the large cleaning jobs that are available to carpet cleaners and maintenance professionals today. With competition as strong as it is in most communities, you have invested in not only a cleaning tool, but a marketing tool that will enhance your professional image in every way. The RX-20 is REVOLUTIONARY. Your foresight in purchasing this ultimate "cleaning machine" will be rewarded with the knowledge that you care enough to give your customer the maximum cleaning process available.

Using the RX-20 in your business will turn you into a professional carpet cleaning *operator*, rather than a professional *laborer*.

Once again, congratulations to another cleaning professional who will not wait for tomorrow, and will not have to compete against the RX-20. The competition will have to try and compete with you!

An Evolution That Had To Happen

Your new RX-20 has been precision engineered to bring you to the state-of-the-art in carpet cleaning. In the past, a wand technician had to supply all the pressure and motion to do the cleaning.

The RX-20's weight distribution and rotary motion enable the technician to maneuver the unit easily with less fatigue and without back strain.

The RX-20's electric motor drives its precision transmission which, in turn, rotates the star assembly. Cleaning solution is injected through the center of the gearbox shaft directly to the five spray jets. Soiled solution is then extracted from the carpet by five cleaning heads and drawn through the aluminum exhaust manifold to your cleaning system's recovery tank.

NOTE: The operating temperature and pressure of the cleaning solution as well as the vacuum power depends entirely on the type of cleaning system you use.

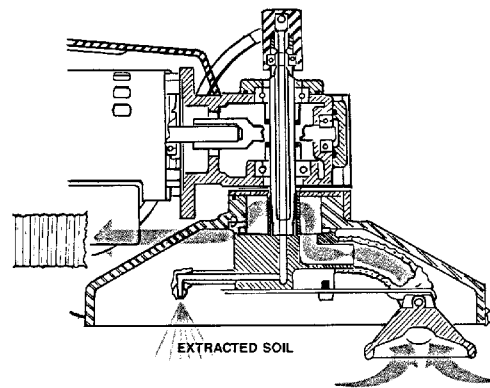

Construction

The base, exhaust manifolds, handle, gearbox housing and cleaning heads are all cast or molded aluminum. Other parts are either metal or high impact plastic.

Machine Specifications

	RX-20 CMX-20	HIGH SPEED RX-20 HIGH SPEED CMX-20
Length:	27"	23"
Base Width:	15"	15"
Height:	45"	43"
Weight:	75 lbs.	70 lbs.
Motor:	115 V, ¾ HP	115 V, ½ HP TEFC
Gearbox:	1725 RPM Input 90 RPM Output	1725 RPM Input 130 RPM Output Permanently Lubricated Helical Gear Drive
Oil Capacity:	14 oz.	14 oz.

Assembly Instructions

To prepare your machine for use, follow these instructions:

- a) Remove the machine from the packaging. Inspect the machine carefully for any damage that may have occurred during shipping. If any oil spillage is noted be sure to check the gearbox lubricant level (see instructions).
- b) Now attach the star assembly to the base. Lean the machine back and rest it on the handle. Thread the star assembly onto the exposed shaft remembering to go in a counter-clockwise direction.
- c) **Important:** Remove the solid shipping plug from the top of the gearbox and replace it with the vented plug provided before operating the machine.

Your machine is now ready to operate.

If you purchased a **High Speed RX-20**, it may require assembling if it was shipped in two separate boxes.

To assemble:

- a) With the three bolts provided, attach the handle to the base using a 9/16" wrench (see illustration to right).
- b) Next attach the stainless steel hose to the rotary union using 7/16" and 1/2 " wrenches.
- c) Next attach the 2" vacuum hose to the base and handle using the hose clamps provided.
- d) Next plug the male and female electrical connections together.

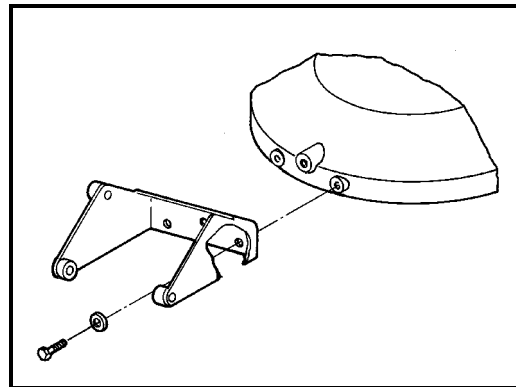

Operation

Preparation

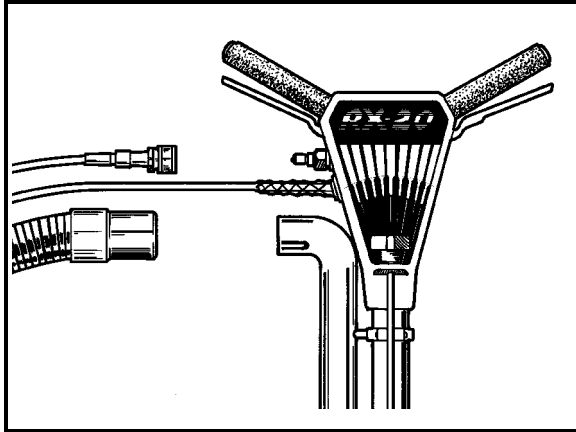

1. Handle Adjustment: Loosen the adjustment knob located below the RX-20 label (turn counter-clockwise to loosen, clockwise to tighten). Adjust the handle to a comfortable height. Several adjustments may be needed before a desirable operating position is found.

NOTE: Most technicians have found better control and less fatigue when the handle is in a low position just around the hip line. There is an ideal position for each person which will ensure the RX-20 will do the work instead of you.

2. Solution and Vacuum Hose Hookups: Your RX-20 is equipped with 440 male quick connect for the solution hose hookup and a two inch OD vacuum hose inlet (refer to the above illustration). A solution hose with a 440 female

quick connect is required. The vacuum inlet requires a two inch ID vacuum hose for proper air flow with a truck mounted system.

IMPORTANT: The vacuum hose must be in good condition to ensure maximum airflow. If you do not have a 440 female quick connect and can not find it locally, it can be ordered from the HydraMaster Parts Department. Call (206)775-7276 and request part # 052-051 (440 QC).

- 3a. Electrical Cord Hook Up (Regular RX-20): The 50 foot electrical cord on your RX-20 is a detachable three-prong grounded line requiring a three-prong, 15 amp receptacle. A three-prong to two-prong adapter may be used, providing its ground wire is properly attached to a grounded terminal.

CAUTION: Do not, under any circumstances, remove the ground prong from your RX-20 power cord. Serious injury or death may result.

To connect the power cord to the unit, insert the male twist-lock plug (from the unit) into the female end (on the power cord) and twist until they are securely locked together.

- 3b. Electrical Cord Hook Up (High Speed RX-20): The 50 foot electrical cord on your RX-20 is a permanently attached, three-prong grounded line requiring a three-prong, 15 amp receptacle. A

three-prong to two-prong adapter may be used providing its ground wire is properly attached to a grounded terminal.

CAUTION: Do not, under any circumstances, remove the ground prong from your RX-20 power cord. Serious injury or death may result.

Operating Instructions

- Control Functions:** There are control triggers located on each side of the handle under the rubber hand grips. As you operate the RX-20, the trigger on your right hand side controls the electric motor that drives the cleaning heads. On the left hand side, the trigger controls the high pressure solution spray. The air flows constantly while the RX-20 is in operation.

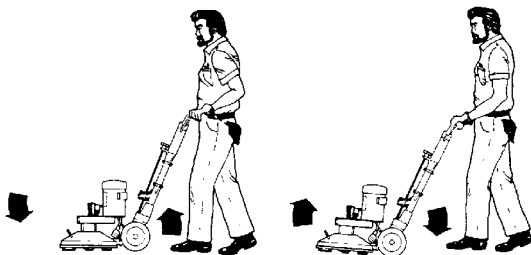

- Maneuvering Your RX-20:** Your RX-20 maneuvers like a rotary floor machine. To move the RX-20 to the right, lift the handle slightly. To move it to the left, push down on the handle slightly. The more you lift or lower the handle, the faster the RX-20 will move.

To move forward and backward, position the handle so that the unit remains stationary, then push forward or pull back.

To familiarize yourself with your RX-20, practice on an open carpeted area. Depress both the solution trigger and motor trigger and move the RX-20 slowly in a three to five foot arc, as shown in the cleaning patterns on the following page.

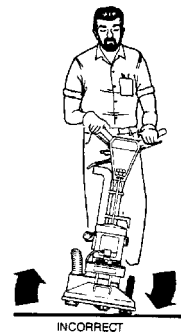

CAUTION: Do not operate your RX-20 on dry carpets. The friction generated by the revolving cleaning heads may damage fibers in the carpet.

Once you have become familiar with the speed and movement of the machine, practice making it hover in one spot. (The hovering maneuver is useful for removing stubborn stains, as well as removing furniture indentations.)

Do not tilt machine sideways while moving forward and backward. A loss of control may result in damage to the unit or location.

Cleaning Information

Cleaning Patterns

For regular carpet cleaning, use an overlapping arc pattern three times over the same area (two passes with solution and one pass for drying). When cleaning carpets, first clean in a circular pattern, then use the overlapping arc pattern to dry the area.

(NOTE: Dirtiest areas may require two or more cleaning passes.) Using either pattern, you should develop a comfortable rhythm. To obtain maximum performance from your RX-20, move it slowly and deliberately with a 50% overlap, giving it time to clean and extract. (Unlike a manual wand, the RX-20 is doing the work you had to do in the past.) A steady pace rather than a frenzied one will increase efficiency and production and decrease fatigue.

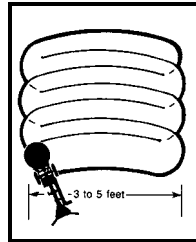

Arc

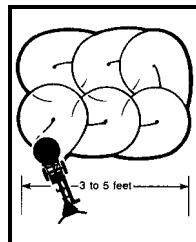

Circular

The Following Cautions Should Be Observed While Cleaning:

1. DO NOT operate your RX-20 over metal floor moldings. Damage to both the molding and the cleaning head will result.
2. DO NOT operate your RX-20 on

hardwood floors.

3. DO NOT operate your RX-20 over loose or unraveled carpet seams. The cleaning head may catch and cause further damage.
4. DO NOT operate your RX-20 on concrete floors. It will develop sharp edges on the extraction heads that will damage carpet fibers.
5. DO NOT clean over the edge of a loose carpet. Instead, clean only up to the edge. Damage may occur should the extraction heads catch the loose carpet.

Special Information

During the cleaning of some plush carpets you may notice a "pilling" effect. With an RX-20, loose yarns form balls and are kicked aside as the cleaning heads revolve. This is normal when aggressive cleaning or even normal vacuuming takes place, as evidenced by a number of dead, loose yarns in the vacuum cleaner bag. These loose yarns, in most cases, are short staple yarns or filler yarns used to give the carpet a denser appearance. Because your RX-20 weighs approximately 90 pounds and rests on five four-inch cleaning heads, the yarns are not sucked up into the vacuum heads as they are with a vacuum cleaner or old-style cleaning wand.

CAUTION: On older, rubber backed, glued down carpets that may be de-laminating with age, the RX-20 may cause further de-lamination. When in doubt, DO NOT use your RX-20.

The RX-20 has been very successful in restoring badly matted traffic lanes in front of doorways and sofas. Even pivot areas can be brought back to life again, in most cases. "Cornrowing" in hallways can also be eliminated with minimal effort.

Cleaning Hints

- A. Most cleaners customarily clean their way out of an area or room. With the RX-20, it is possible to clean into an area or room, as shown in the illustrations below, so that the hoses are dragged behind you during the cleaning process rather than kicked out of the way as you back out of an area. The "cleaning into" method works especially well in hallways or confined areas.

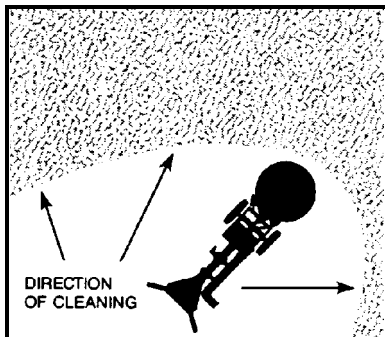

- B. The RX-20 is a very aggressive carpet cleaning power head and will leave the carpet with a freshly-cleaned appearance. The carpet should be brushed or groomed after the cleaning process to remove any swirl marks left behind.

Machine Maintenance

Good care and regular maintenance of your RX-20 will result in a long, dependable life for the unit. Keep in mind that your RX-20 will be in full view of your customer. An RX-20 that is dirty and unkempt in appearance can cause your image to suffer. You are offering your customer the latest in cleaning technology. Therefore, it is important that your company image reflect your desire to give your customer THE BEST.

The surface finish on your RX-20 is a durable, baked on epoxy coating and is easily cleaned with a damp cloth. To further protect the finish, a light coat of good silicon base polish should be applied periodically.

Lubrication and maintenance play a key role in the life of your RX-20. Hence, the following daily and periodic maintenance steps must be followed. Train yourself to maintain your unit on a regular schedule until it becomes habitual.

Daily Maintenance

1. Inspect the power cord for cuts, breaks, etc. Repair as needed.
2. Inspect the vacuum hoses for breaks or tears. Repair or replace as necessary.
3. Visually inspect your RX-20 for water leaks, damage to the cleaning heads, etc. Repair as

necessary.

4. Remove the in-line solution filter screen by unscrewing the 7/8 inch hex nut protruding from the back of the handle. Rinse under water to remove debris. If necessary, use a toothbrush to remove stubborn particles.

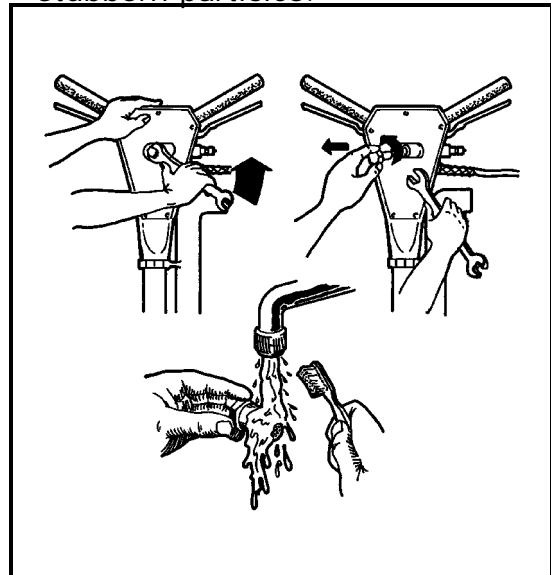

5. Check the jet spray for evenness.

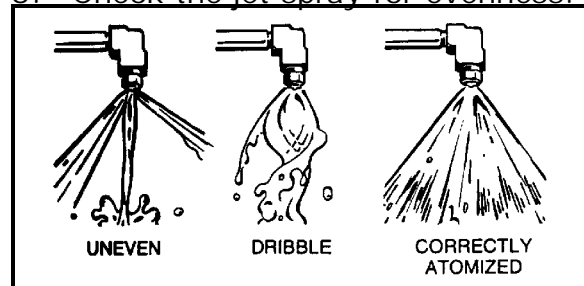

An uneven spray will cause improper flow of the cleaning solution.

6. Remove the cleaning head. It unscrews in the same direction it turns during operation (or clockwise when looking at it from the underside).

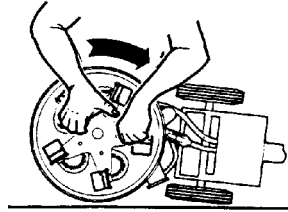

Once you have loosened the assembly, spin it off with your hands. If the cleaning head is difficult to remove, you may use a $\frac{3}{4}$ inch socket wrench on the exposed center nut. To prevent the gearbox from turning, the output shaft will accept a $\frac{5}{8}$ inch wrench just below the rotary union. Wash the cleaning heads and shroud assembly with a garden hose, being careful not to wet the electric motor assembly. Clean any lint build-up from the cleaning heads and vacuum hoses (lint build-up will restrict proper airflow and prolong drying time).

◆ CAUTION ◆

7. Clean off any debris that may have accumulated on the gearbox shaft or the inside threaded bore of the hub. An accumulation of debris here, if not removed, may damage the gearbox oil seal. This will result in loss of oil in the gearbox. If the gearbox is operated without oil, severe damage may occur.

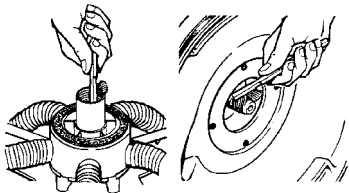

8. Lubricate the felt vacuum seal on top of the hub with a quality, 30 weight SAE motor oil. Also, put a few drops into the hub threads.

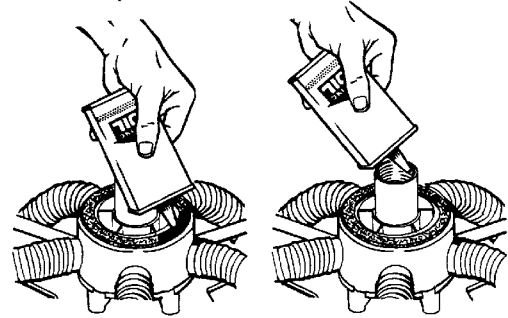

9. Coat the shaft with Pennz-Guard or a similar lubricant. Reinstall the vacuum head assembly onto the shaft by rotating it counter-clockwise.

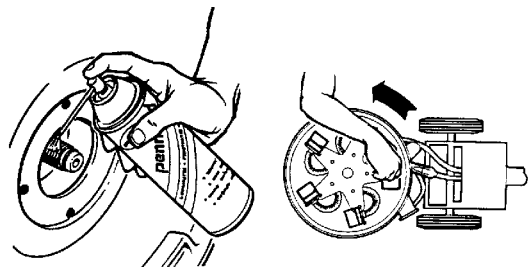

IMPORTANT: While rotating the vacuum head assembly in the counter-clockwise position, make sure that it spins freely all the way down. If it begins to require the slightest finger tip pressure, unscrew it and brush off the threads. All it takes is the slightest grain of dirt or sand to obstruct the threads. If you turn too far onto a grain of dirt, the hub may become locked onto the shaft of the gearbox.

Periodic Maintenance

Regular RX-20 only:

Check the oil in the gearbox. The unit must be on a level surface to get an accurate reading. Change the oil in the gearbox every 100 hours. Use 80-90 weight gear oil to reduce friction and allow the gearbox to run at a cooler temperature. With the unit level, drain the oil. Next fill the gearbox with new oil at the oil port on the front until it dribbles out of the inspection port.

NOTE: Normal wear and tear on your new gearbox will cause small amounts of metal splinters to rub loose during the first 10 hours of use. Therefore, we recommend that you *change the oil after 10 hours*, and after that every 100 hours.

High speed RX-20:

Check the oil the gearbox. Check the oil level in the gearbox on a monthly basis. This is a permanently lubricated gearbox. You do not need to change the oil. However, maintaining the proper oil level is important. To check the oil level, remove the vent plug and look into the gearbox. Turn the star until you can see the inspection hole in the gear. With the RX-20 sitting flat on a table or the floor, the oil level should be up to, but not above, the middle of the gear. If oil needs to be added, use a quality 80-90 weight gear oil.

NOTE: When checking the oil level in the gearbox, you can use a toothpick as a dip stick. The oil level should read $\frac{3}{8}$ th of an inch.

Transport And/Or Storage

Whenever your RX-20 is transported or stored, it is recommended that the cleaning head be removed. The machine will then sit flat on the floor and remain more stable, especially during transport.

Freeze Warning And Protection

Your RX-20 can sustain damage from freezing, as can any equipment that functions with the use of water. Care must be taken to protect this tool from freezing just as you do your other equipment. To protect it from freezing, simply blow air from a gas station air hose through the solution quick connect with the valve open. This will blow all water from the valve, solution line, rotary union and jet assembly. Open and close the valve several times to ensure that all water is removed.

Parts And Assemblies

HydraMaster has every part in stock. For parts ordering or servicing call:

Parts Department at (425) 775-7276 or

Service Department at (425) 775-7275

Check for a registered HydraMaster Service Center in your area.

Regular Base Assembly

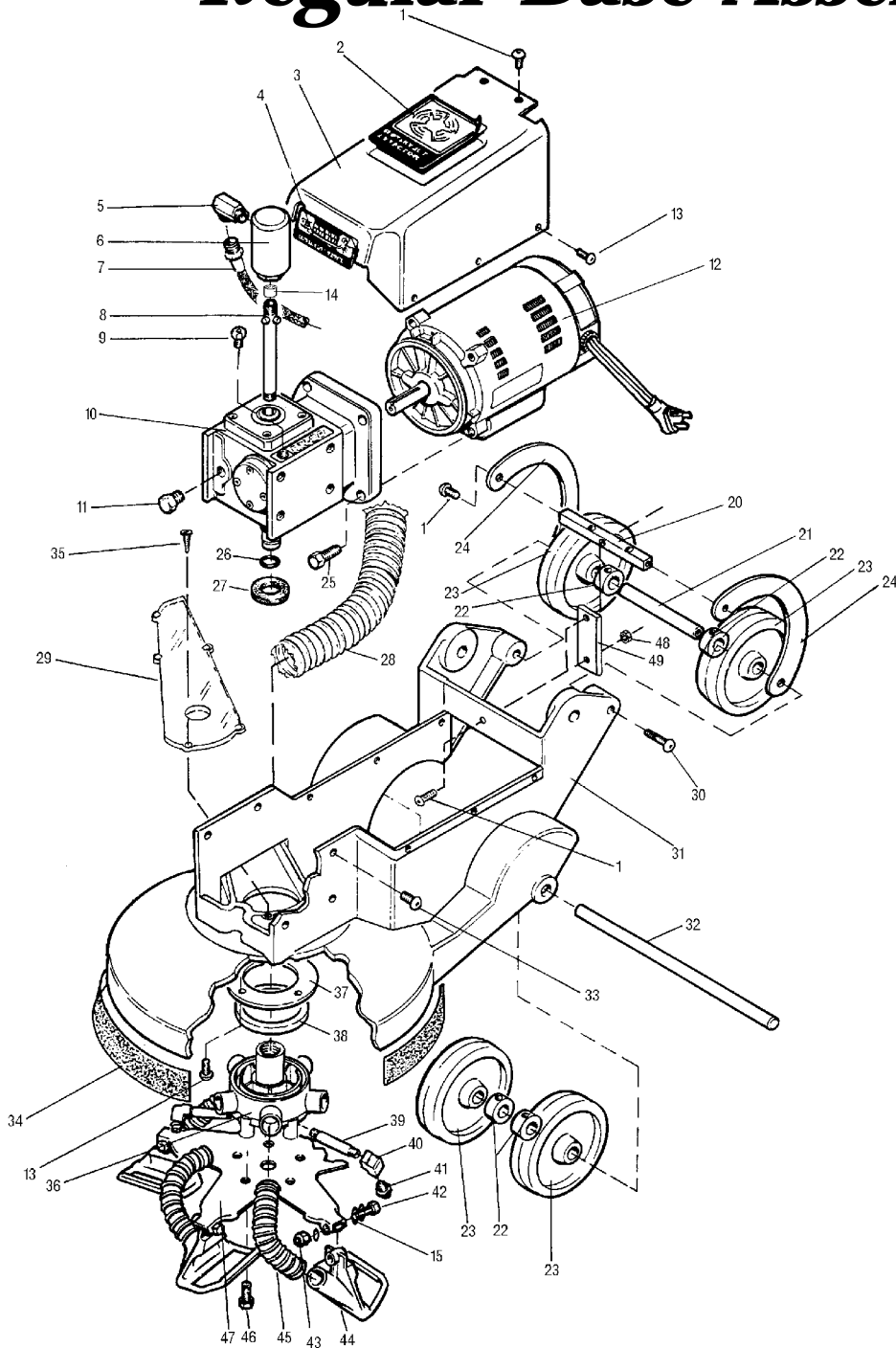

Regular Handle Assembly

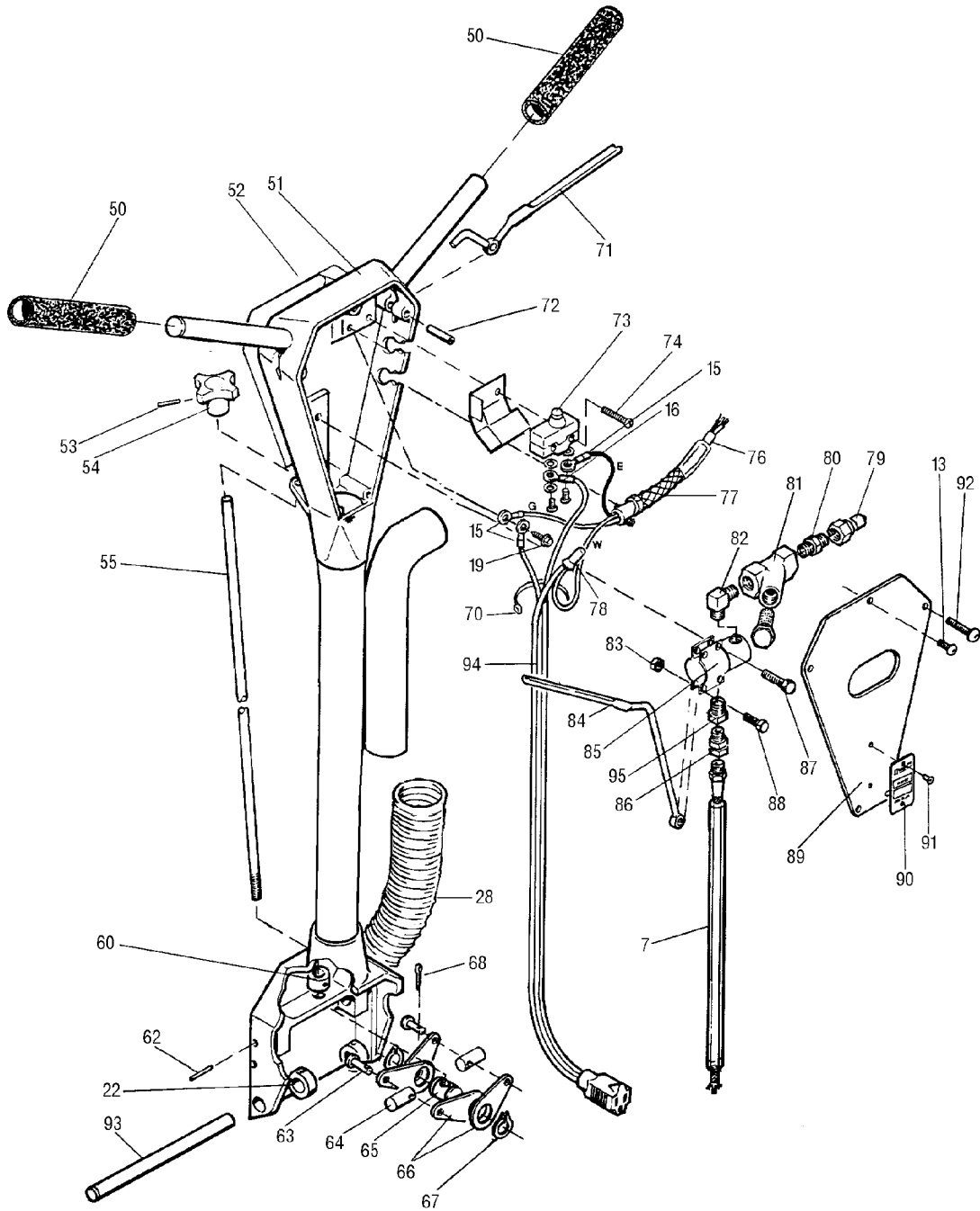

TWIST-LOCK PLUG WIRING DIAGRAM

Item No. 75

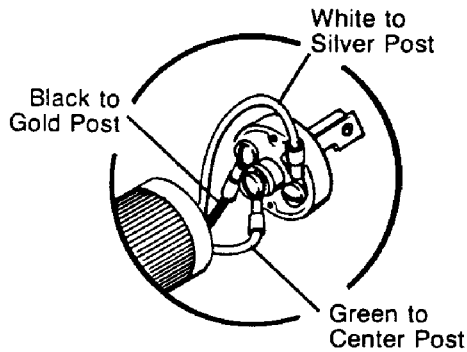

VALVE ASSEMBLY

Item No. 85

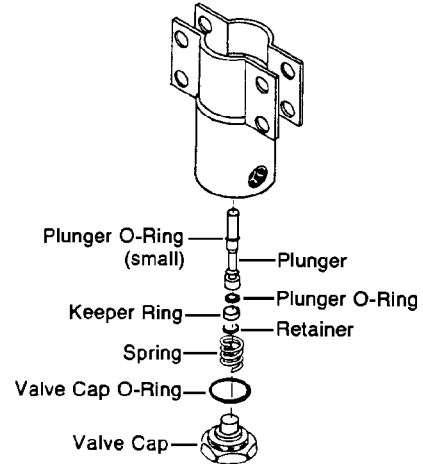

Regular RX-20 Parts List

ITEM	PART NO	DESCRIPTION	QTY
1	000-143-132	Screw, 10-24 x ¾" HHC s/s	2
2	000-081-001	Label, RX-20 Machine (3 pc set)	1
3	000-041-026	Cover, RX-20 Motor	1
4	000-081-001	Label, RX-20 Machine (3 pc set)	1
5	000-052-002	2MA - 2UFS	1
6	000-052-276	Rotary Union, ⅛" NPT	1
7	000-068-175	Hose, Solution Valve to Rotary Union	1
8	000-052-296	Nipple, Brass RX Gearbox Extention	1
9	000-106-014	Plug, RX-20 Gearbox Vent	1
10	000-107-091	RX-20 Gearbox	1
11	000-106-001	Plug, ⅛" Brass	1
12	604-052-007	RX-20 Electric Motor Assembly	1
13	000-143-166	Screw, 10-24 x ⅜" BTN HD Cap s/s	14
14	000-052-288	Coupler, ⅛" Machined Rotary Union Fitting	1
15	000-174-049	Washer, 5/16" s/s Flat	3
19	000-143-118	Screw, #8 x ½" HXWSHD SM	2
20	000-015-066	Bracket, RX-20 Hood Wrinkle Black	1
21	000-141-001	Axle, 5½" Skid	1

ITEM	PART NO	DESCRIPTION	QTY
22	000-020-005	Collar, ½" Set	6
23	000-177-002	Wheel, 5" Rubber	4
24	000-107-096	Handle Arc	2
25	000-143-018	Screw, ⅜-16 x 1" HHC	4
26	000-097-009	O-Ring, Cast Gearbox Shaft	1
27	000-154-013	Spacer, 1" RX-20 Gearbox Shaft	1
28	000-068-034	Hose, 2" Black Vacuum	3 Ft
29	000-041-017	Cover, Sight-Side Port	1
30	000-143-164	Screw, 5/16-18 x 2" BTN HD Cap s/s	2
31	000-006-008	Base, RX-20 Side Port	1
32	000-141-010	Axle, RX-20 Front Skid	1
33	000-143-142	Screw, 5/16-18 x ¾" BTN HD Cap s/s	8
34	000-078-108	Kit, Roto Shroud Bumper and Rivet	1
35	000-143-114	Screw, 10-24 x ½" FHM Phillips s/s	4
36	000-107-0221	Hub with Ring, Single Lead Thread	1
37	000-105-008	Plate, Cast RX-20 Base - Seal	1
38	000-057-047	Gasket, RX-20 Felt Hub	1
39	000-052-080	Nipple, ⅛" x 4" Brass	5
40	000-052-089	Elbow, ⅛" Brass Female	5
41	000-076-037	Jet, H ⅛VV 80015 SS - STD	5
Optional:	000-076-052	Jet, 1) 2 Piece Set Twist Out	5
	000-076-058	Jet, 1) 2 Piece Brass #8001	5
42	000-143-158	Screw, 5/16-18 x 1¼" HHC s/s	5
43	000-094-009	Nut, ¼-20 s/s Nylock	5
44	000-064-012	Head, New RX Skid Assembly	5
45	000-068-174	Hose, Vac Hub/Skid	5
46	000-143-148	Screw, 5/16-18 x ½" HHCS s/s	5
47	000-107-089	Heat Treated Star, s/s	1
48	000-094-034	Nut, 10-24 s/s Nylock	2
49	000-015-078	Bracket, RX-20 Hood Support Complete	1
50	000-061-001	Handle, Foam Grip	2
51	000-061-016	Handle, RX-20	1
52	000-081-001	Label, RX-20 Machine (3 pc set)	1
53	000-103-014	Pin, ⅛ x ¾ Roll	1
54	000-061-015	Knob, Adjusting	1
55	000-141-002	Rod Assembly, RX-20 Handle Adjusting	1

ITEM	PART NO	DESCRIPTION	QTY
60	000-020-004	3/8" Set Collar	1
62	000-103-015	Pin, 5/32 x 1" Roll	1
63	000-103-012	Pin, 1/4 x 7/8 "Clevis	4
64	000-107-101	Plunger	2
65	000-094-030	Nut, Adjusting	2
66	000-107-097	Link	1
67	000-139-006	Ring, 5/8" Snap	4
68	000-103-013	Pin, 3/32 x 1/2" s/s Cotter	2
70	000-162-001	Tie Wrap, 4" Nylon	2
71	000-167-010	Trigger, RX-20 Power	1
72	000-107-103	Trigger, Pivot	1
73	000-157-032	Switch, Micro	1
74	000-143-048	Screw, 6-32 x 1" Pan Head	2
76	000-178-004	Cord, 14/3 x 50' Gray - Power	1
77	000-108-012	Protector, Power Cord Relief Grip	1
78	000-094-021	Wire Nut, Yellow	1
79	000-052-050	Quick Connect, 440 Male with Viton	1
80	000-052-071	Nipple, 1/4 Brass Hex	1
81	000-049-033	Filter, 1/4" Inline Y	1
82	000-052-301	Elbow, 1/4" Male x 1/4" Male	1
83	000-094-008	Nut, 1/4 - 20 Hex	1
84	000-167-009	Trigger, o/s RX-20 Brass Solution Valve	1
85	000-169-058	Valve, s/s HM Solution	1
86	000-052-001	2M - 2UFS	1
87	000-143-005	Screw, 1/4-20 x 1 3/4" HHC	2
88	000-143-002	Screw, 1/4-20 x 1" HHC s/s	1
89	000-041-013	Cover, Handle Access	1
90	000-105-018	Plate, RX-20 Serial ID	1
91	000-140-001	Rivet, AB4 - 3A Pop	2
92	000-143-167	Screw, 10-24 x 1 1/4" BTN HD s/s	1
93	000-141-009	Rod, RX-20 Handle Pivot	1
94	604-051-003	Internal Wire Harness	1
95	000-052-059	Bushing, 1/4M x 1/8F Brass	1
Not Shown:			
	000-094-036	Nut, 1/2" NPT Pipe Plastic Used with Item No. 77	1

High Speed Handle Assembly

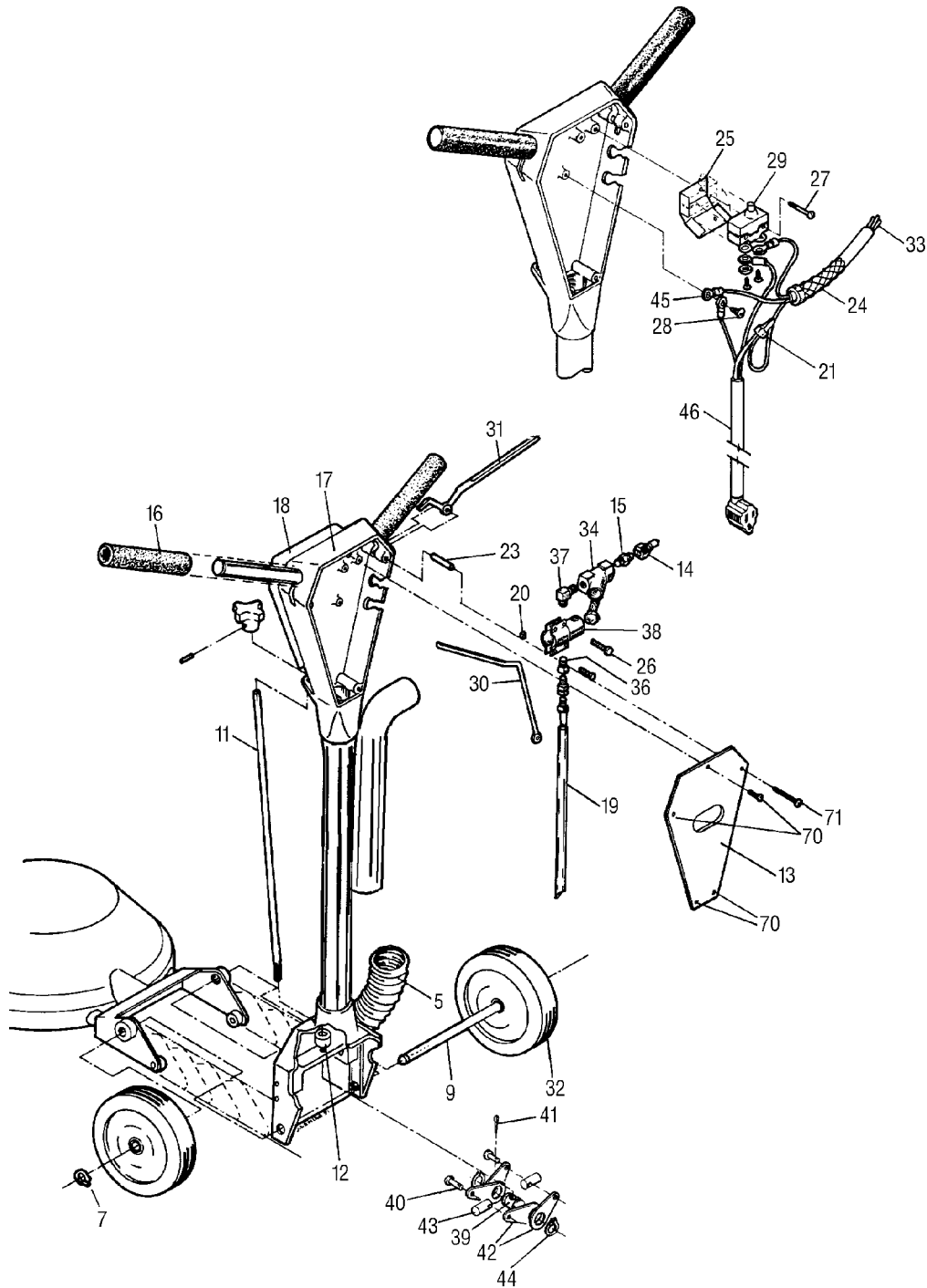

High Speed Base Assembly

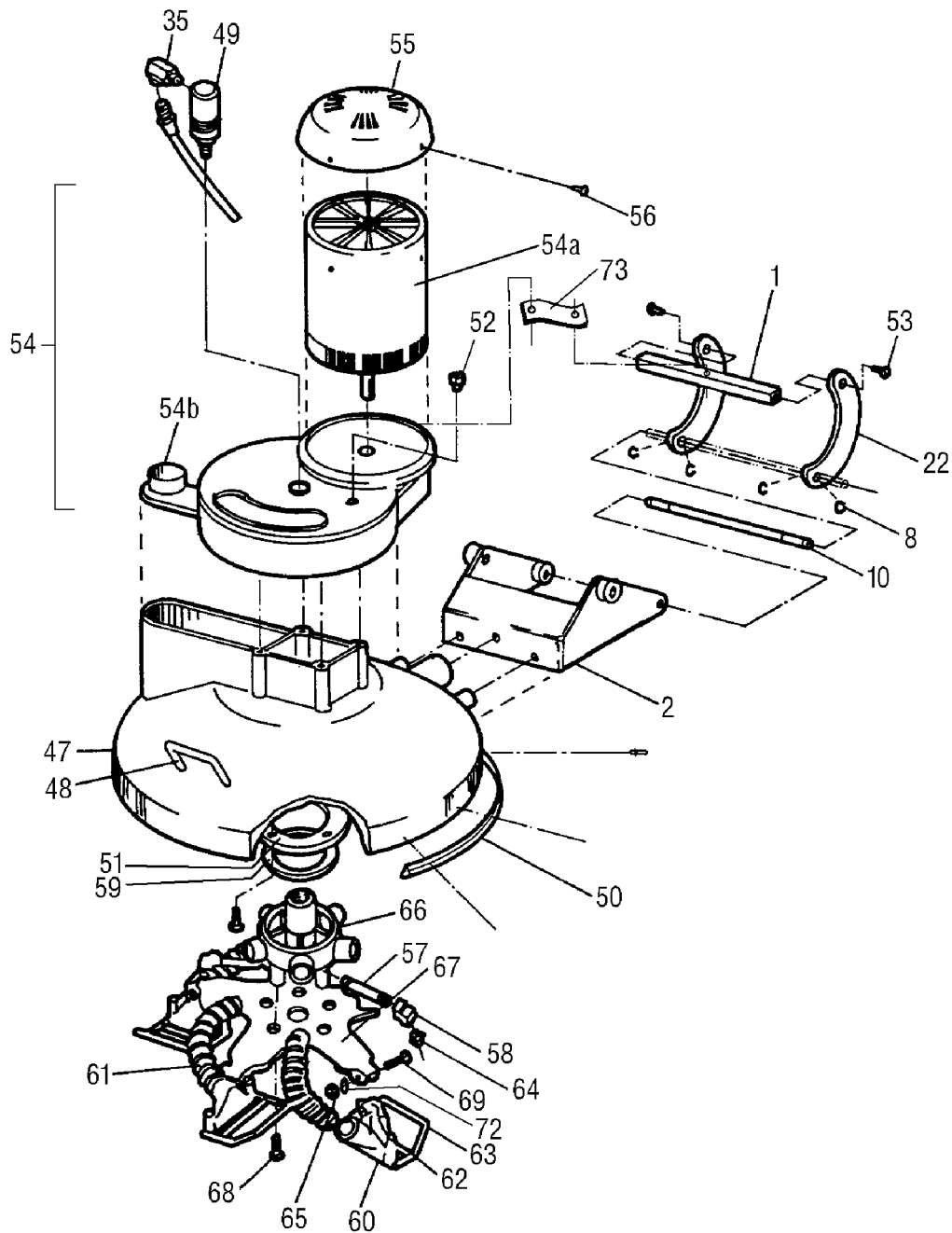

RX-20 High Speed Parts List

ITEM	PART NO	DESCRIPTION	QTY
1	000-015-066	Bracket, RX-20 Hood Wrinkle Black	1
2	000-015-139	Bracket, Hi Speed RX Handle Brace	1
5	000-068-040	Hose, Base Out - Manifold	1
7	000-139-009	Ring, Snap Ring (E-Clip) x ½"	2
8	000-139-010	Ring, Snap Ring (E-Clip) x 5/16"	4
9	000-141-004	Axle, Hi Speed RX Wheel	1
10	000-141-005	Rod, Hi Speed RX-20 Handle Arc	1
11	000-141-006	Rod Assy, Hi Speed RX Handle Adjusting	1
12	000-020-004	Collar, ⅜" Set	1
13	000-041-013	Cover, Handle Access	1
14	000-052-050	Quick Connect, 440 Male with Viton	1
15	000-052-071	Nipple, ¼ Brass Hex	1
16	000-061-001	Handle, Foam Grip	2
17	000-061-017	Handle, Hi Speed RX-20	1
18	000-081-001	Label, RX-20 Machine (3 pc set)	1
19	000-068-175	Hose, Solution Valve to Rotary Union	1
20	000-094-010	Nut ¼-20 s/s Hex	1
21	000-094-021	Nut, Wire - Yellow	1
22	000-107-096	Handle Arc	2
23	000-107-103	Trigger Pivot	1
24	000-108-012	Protector, Power Cord Relief Grip	1
25	000-108-014	Shield, RX-20 Micro Switch	1
26	000-143-002	Screw, ¼-20 x 1" HHC s/s	3
27	000-143-048	Screw, 6-32 x 1" Rnd HD Mach s/s	2
28	000-143-336	Screw, 10-32 x ¼" s/s Pan Head	1
29	000-157-032	Switch, Micro	1
30	000-167-009	Trigger, o/s RX-20 Brass Solution Valve	1
31	000-167-010	Trigger, RX-20 Power	1
32	000-177-001	Wheel, 8" Hi Speed RX-20	2
33	000-178-004	Cord, 14/3 x 50' Gray - Power	1
34	000-049-033	Filter, ⅜" Inline Y	1
35	000-052-001	2M - 2UFS	1
36	000-052-059	Bushing, ¼ M x ⅛ F Brass	1

ITEM	PART NO	DESCRIPTION	QTY
37	000-052-301	Elbow, ¼" Male x ¼" Male	1
38	000-169-058	Valve, s/s HM Solution	1
39	000-094-030	Nut, Adjusting	1
40	000-103-012	Pin, ¼ x 7/8" Clevis	2
41	000-103-013	Pin, 3/32 x ½" s/s Cotter - RX	2
42	000-107-097	Link	4
43	000-107-101	Plunger	2
44	000-139-006	Ring, 5/8" Snap	2
45	000-037-016	Terminal, #10 Ring - 16 AWG	1
46	000-178-039	Cord, 14/3 x 6' Gray	1
47	000-006-009	Base, Hi Speed RX-20	1
48	000-061-027	Handle, RX Express Base - Lift	1
49	000-052-276	Rotary Union, 1/8" NPT	1
50	000-078-108	Kit, Roto Shroud Bumper and Rivet	1
51	000-105-008	Plate, Cast RX-20 Base - Seal	1
52	000-106-014	Plug, RX-20 Gearbox Vent	1
53	000-143-166	Screw, 10-24 x 3/8" s/s BTN HD Cap	2
54	604-052-005	Hi Spd RX-20 Motor/Gearbox Assy	1
54A	604-052-006	Hi Spd RX-20 Elect Motor Assy	1
54B	000-059-001	Gearbox Complete, Spur	1
55	000-041-123	Cover, ½ HP TEFC Motor	1
56	000-143-096	Screw, 3/8 16 x 3/4" s/s BTN HD	3
57	000-052-080	Nipple, 1/8" x 4" Brass	5
58	000-052-089	Elbow, 1/8" Brass Female	5
59	000-057-047	Gasket, RX-20 Felt Hub	1
60	000-064-012	Head, New RX Skid Assembly Complete	5
61	000-068-174	Hose, Vac Hub/Skid	1
62	000-064-011	Head, New RX Cast Skid-Weldment	1
63	000-107-095	Skid Bottom, New Style RX Shoe	1
64	000-076-037	Jet, H 1/8VV 80015 SS-STD	5
Optional:	000-076-052	Jet, 1) 2 Piece Set Twist Out	5
	000-076-058	Jet, 1) 2 Piece Brass #8001	5
65	000-094-009	Nut, 5/16-18 s/s Nylock Half	5
66	000-107-0201	Hub with Ring, Double Lead Thread	1

ITEM	PART NO	DESCRIPTION	QTY
67	000-107-089	S/S Heat Treated Star	1
68	000-143-012	Screw, 5/16-18 x 3/4" s/s HHC	5
69	000-143-162	Screw, 5/16 x 1" Stripper - 1/4-20 s/s	5
70	000-143-166	Screw, 10-24 x 3/8" s/s BTN HD Cap	4
71	000-143-065	Screw, 10-24 x 1 3/4" s/s BTN HD Cap	5
72	000-174-049	Washer, 5/16" s/s Flat	3
73	000-015-009	Bracket, Hi Speed RX Handle Brace	1
Not Shown:			
	000-094-036	Nut, 1/2" NPT Pipe Plastic Used with Item No. 24	1
	000-143-096	Screw, 3/8 - 16 x 1" HHC s/s Used with Item No. 54	3
	000-174-055	Washer, Latch Pivot Used with Item No. 54	3
	000-174-057	Washer, 3/8" s/s Lock Used with Item No. 54	3

Repair

REMOVAL OF COMPONENTS

Felt Vacuum Seal Replacement: A worn or unlubricated seal will not form a proper seal. Lack of a proper seal will impair the vacuuming capabilities of the unit and therefore leave behind more water in the carpet than is

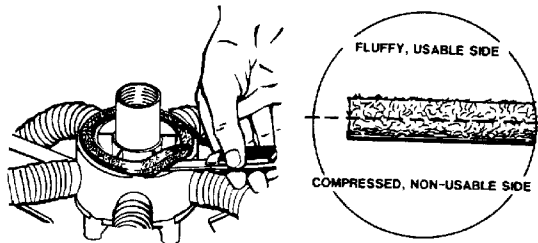

desirable.

First, remove the vacuum head assembly as previously described. Using a pocket knife, carefully pry the seal up and lift it out. If the seal appears worn or glazed so that it will not lubricate well, try turning it over. If that does not work, or if it is damaged, replace it with a new one. We recommend changing the felt seal after 10 hours of use. Replace it with a spare, soaked seal. Press the seal in place and saturate it with a quality 30 weight SAE motor oil. Always place the flattened, used seal in an oil bath to rejuvenate. (**NOTE:**

A tuna fish can is the right size and shape and does not require a large amount of oil.) This seal and its condition play an important part in the optimum

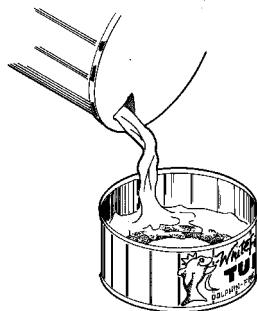

performance of your RX-20.

High Pressure Valve Assembly: The valve assembly's moving parts will eventually wear out its time. Its repair or replacement is a relatively simple operation.

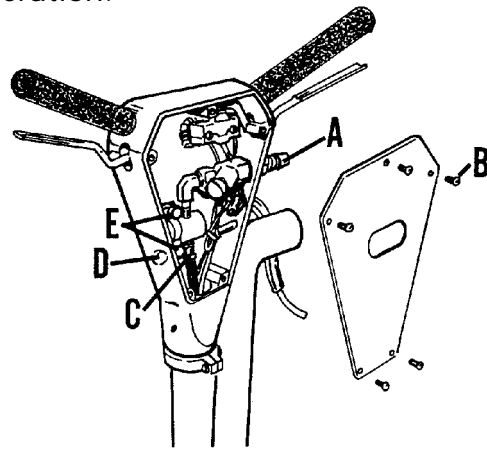

1. Remove the 440 male quick connect (A) with a wrench.
2. Remove the five allen head screws (B) in the back plate on the handle and lift the back panel off.
3. Disconnect the stainless steel hose (C) from the bottom of the valve assembly.
4. Remove the bolt (D) holding the trigger.
5. Remove the two bolts (E) holding the valve assembly in the handle and pull out.
6. The valve may now be rebuilt or replaced. **CAUTION:** If the valve has been frozen, inspect it for leakage before reinstalling the back plate.

Troubleshooting

I. Problem: Low Vacuum Flow at the Cleaning Heads

Cause: Hub not sealing properly.

Solution: Replace felt seal with a lubricated one.

Cause: Restricted air flow.

Solution: Check all vacuum hoses for restrictions.

Cause: Low vacuum flow from power source.

Solution: Refer to troubleshooting section of equipment manual.

II. Problem: Low Water Flow at Cleaning Heads
(Indicated by Irregular Water Temperature)

Cause: Restricted jets.

Solution: Remove jets and clear them of debris.

Cause: Clogged water strainer.

Solution: Remove water strainer and clean.

Cause: Kinked or clogged solution hose.

Solution: Remove hose. Repair or replace.

Cause: Cleaning hub not properly threaded to shaft.

Solution: Remove cleaning hub from shaft. Clean and re-thread onto shaft.

III. Problem: Water Leak at Rotary Union

Cause: Foreign matter in rotary union seal.

Solution: Dismantle rotary union. Clean. Reassemble and install.

IV. Problem: Water Leak at Valve

Cause: Ruptured plunger or valve o-ring.

Solution: Repair or replace damaged plunger, o-ring, seal. Check for freeze damage.

V. Problem: Loss of Oil From Gearbox

Cause: Loose or ruptured oil seal.

Solution: Replace damaged oil seal. Refill gearbox with oil.

VI. Problem: No Power

Cause: RX-20 wiring or power source.

Solution: Have an electrician inspect unit for possible wiring or motor problems.

Cause: Overload power source.

Solution: Locate an unused power source.

Cause: Gearbox.

Solution: Repair or replace gearbox.

VII. Problem: Head Wobbles During Operation

Cause: One leg of star bent.

Solution: Straighten star.

Limited Warranty Plan

HydraMaster warrants Rotary Extractor machines of its manufacture to be free from defects in material and workmanship if properly installed, maintained, and operated under normal conditions with competent supervision. No person, agent, representative or dealer is authorized to give any warranties on behalf of HydraMaster, nor to assume for HydraMaster any other liability in connection with any HydraMaster products. This warranty shall extend to the original purchaser of said equipment for the periods listed below from date of installation. If repairs or replacements are made by the Purchaser without HydraMaster's written consent, HydraMaster's warranty shall cease to be in effect.

Machinery, equipment and accessories furnished by HydraMaster, but manufactured by others, are warranted only to the extent of the original manufacturer's warranty to HydraMaster unless otherwise specified in the listing below.

HydraMaster agrees, at its option, to repair at the point of shipment, or to replace without charge, any parts or parts of products of HydraMaster's manufacture, which within the specified warranty period shall be proved to HydraMaster's satisfaction to have been defective when shipped, provided the purchaser promptly notifies HydraMaster, in writing, of such alleged defect. HydraMaster will pay all freight and transportation charges, via normal ground shipping means, for replacement of parts

covered under this warranty.

This warranty covers parts, as specified, and does not cover labor which may be necessary in completing repairs. HydraMaster's liability to Purchaser, whether in contract or in tort arising out of warranties, representation, instructions, or defects from any cause shall be limited to repairing or replacing the defective part or parts. To qualify for warranty coverage, defective parts must be returned to HydraMaster within 30 days. No warranty liability whatsoever shall attach to HydraMaster unless and until HydraMaster has received payment in full for the warranted machine or part.

Except as stated in this section and in the proceeding section and except as to title, there are no guarantees or warranties of merchantability, fitness, performance or otherwise, express, implied or statutory, and HydraMaster shall have no liability for consequential, incidental or other damages howsoever caused.

All components not specifically referenced in the schedule below are covered under this warranty for a period of one (1) year, excepting those parts which are considered, by HydraMaster, to be expendable in normal use.

(Continued on the following page...)

(Limited Warranty Plan continued...)

Freezing of any water or chemical related component will VOID all warranties on water or chemical related components, internal or external, of this equipment.

Deposits and build-up in the water or chemical systems due to hardness in the water used or chemicals which results in deposits, will VOID all warranties on affected components.

All recommended maintenance must be performed by competent service personnel.

Records of periodic maintenance must be kept and copies may be required to be furnished to HydraMaster before this warranty is honored.

Coverage Schedule

Frame, Handle, Body	3 years
Gearbox	Year 1 : 100%
.	Year 2 : 50%
.	Year 3 : 30%
Motor	1 year
Valves, Filters, Hoses	1 year

For service, contact the distributor where the machine was purchased or call our Customer Service Department:

Monday through Friday • 8:00 am To 5:00 pm PST

Parts: (425) 775-7276
Service: (425) 775-7275
Parts and Service FAX: (800) 426-4225



PST



ROCK MT.



CENTRAL



EASTERN



11015 47th Avenue W • Mukilteo, WA 98275