

OWNERS MANUAL

BOB CAT 2/290

By Hydra-Master
Corporation



20309 - 64th Ave. W.
Lynnwood, WA 98036
(206) 775-7272

Printed in USA

INDEX

	PAGE
General Information	2
Warranty	2
Warranty Information	3
Warranty Procedure	3
Purchaser's Responsibility	4
Truck Preparation Information	4
Truck Preparation Illustration	4
Propane Tank Location/Illustration	5
Hard Water Area Map	5
Machine Specifications	5
Spare Parts Recommendation/Parts Orders	5 - 6
Water & Chemical Flow Operation	6
Water Flow Diagram	6
Chemical Flow Diagram	6
High Pressure Pump Information	7
Bypass Valve Assembly Illustration	7
High Pressure Pump/Chemical System Troubleshooting	7 & 16
Model 290 Cat Pump Operating Instructions	8 - 15
Chemical Proportioning and Level Control Illustration	16
Chemical Tank Troubleshooting	16
Heating System Information	16
Heater Operating Instruction	17
Heater Troubleshooting	17
Vacuum System Information	18
Vacuum Flow Diagram	18
Vacuum Tank Filter Bag	18
Vacuum Blower Lubrication (Diagram)	18
Vacuum System Warranty	19
Vacuum System Troubleshooting	20
Engine Manual/Warranty	21 - 28
Engine Troubleshooting	29
Electrical Diagram	30
Electrical Troubleshooting	30
Machine Installation Information	31
Machine Tie Down Cleat Information	31
Propane Hook-Up Illustration	31
Gas Hook-Up Illustration	31
Water Softener Information	32
Jet Assembly	32
Wand Assembly	32
Valve Assembly	32
Machine Operation Instructions	33
Control Panel	33
Operation Precautions	33
Freeze Protection	34
Cleaning and Chemical Precautions and Information	34
Cleaning Stroke Procedure/Over-Wetting	34
Maintenance Procedures	35
Overall Care of Machine	35
Maintenance Log	36

GENERAL INFORMATION

This manual contains installation and operation instructions as well as information required for proper maintenance, adjustment and repair of this unit. Since the first and most important part of repair work is the correct diagnosis of the trouble, a general troubleshooting section and component manual troubleshooting charts have been included for your convenience.

Unlike the garden tractor, lawnmower and cement mixer, all having one or two functions to perform, the truck-mounted carpet cleaning plant has many functions to perform simultaneously.

- Engine has to run consistent RPM.
- Vacuum has to pull air and dirty water back from cleaning site.
- Water pump provides stable pressure at proper water flow for cleaning.
- Chemical has to be injected into the water stream at the right consistency.
- Heater must maintain proper heat.
- Vacuum tank must store dirty water until drained.

As you can see, it is not just a turn key operation with only one thing to worry about, **Does it start?!**

THE SYSTEMS WORK AS FOLLOWS:

The water system takes incoming water at tap (low) pressure, combines it with chemical from the chemical system automatically, pumps it under high pressure through the heating system and out to the cleaning tool. After being sprayed into the carpet being cleaned, the water/chemical/soil solution is extracted by the vacuum system and returned to the waste recovery tank.

As there is no guess work in the manufacture of these highly advanced cleaning plants, there must be none in preparing it to get the job done in the field. It is the purpose of this manual to help you properly understand, maintain and service your cleaning plant. Follow the directions carefully and you will be rewarded with years of profitable trouble-free operation.

It is imperative that **no section** be overlooked when preparing for operation of this equipment.

WARNING

The manufacturer uses this symbol throughout the manual to warn of possible injury or death.

CAUTION

This symbol is used to warn of possible equipment damage.

HYDRA-MASTER WARRANTY POLICY

Effective October 1, 1981

HYDRA-MASTER warranty covers only defective materials and/or workmanship for the periods listed. Labor, and/or diagnostic reimbursement is specifically excluded.

LIMITED WARRANTY

HYDRA-MASTER warrants products of its manufacture to be free from defects in material and workmanship if properly installed, maintained, and operated under normal conditions with competent supervision. No person, agent, representative or dealer is authorized to give any warranties on behalf of HYDRA-MASTER nor to assume for HYDRA-MASTER any other liability in connection with any of HYDRA-MASTER'S products. This warranty shall extend for the periods listed by component below from date of installation. If repairs or replacements are made by the Purchaser without HYDRA-MASTER'S written consent, HYDRA-MASTER'S warranty shall cease to be in effect. No allowance will be granted for any repairs or alterations made by the Purchaser without HYDRA-MASTER'S prior written consent.

Machinery, equipment and accessories furnished by HYDRA-MASTER, but manufactured by others, are warranted only to the extent of the original manufacturer's warranty to HYDRA-MASTER.

HYDRA-MASTER agrees at its option to repair at the point of shipment or to replace without charge f.o.b. point of shipment, any parts or parts of products of HYDRA-MASTER'S manufacture, which within the specified warranty period shall be proved to HYDRA-MASTER'S satisfaction to have been defective when shipped, provided the Purchaser promptly notifies HYDRA-MASTER, in writing, of such alleged defect.

HYDRA-MASTER'S liability to Purchaser, whether in contract or in tort arising out of warranties, representation, instructions, or defects from any cause shall be limited to repairing or replacing of the defective part or parts as aforesaid, f.o.b. point of shipment.

No liability whatsoever shall attach to HYDRA-MASTER until said products have been paid for.

Except as stated in this section and in the preceding section titled "Warranty" and except as to title, there are no guarantees or warranties of merchantability, fitness, performance or otherwise, express, implied or statutory, and HYDRA-MASTER shall have no liability for consequential, incidental or other damages, howsoever caused.

ENGINE: (Thru original Manufacturer. See Briggs & Stratton Warranty)	1 year
VACUUM BLOWER: (Thru original Manufacturer. See Fuller warranty)	1 year
PROPANE HEATER:	1 year
VACUUM RECOVERY TANK/CHEMICAL MIX TANKS:	1 year
FRAME/COVER ASSEMBLIES:	1 year
HIGH PRESSURE PUMP: (Thru original Manufacturer. See Cat Pump warranty)	1 year
HIGH PRESSURE BY PASS VALVE:	90 days
CHEMICAL PROPORTIONING SYSTEM:	90 days
GAUGES, METERS, SWITCHES, WIRE HARNESS, FUEL PUMP:	90 days
INTERNAL MACHINE HOSE:	90 days
EXTERNAL VACUUM HOSE, SOLUTION HOSE, QUICK CONNECTORS:	30 days
SS CLEANING WAND: (Except valve & jet assembly)	6 months
BELTS, FITTINGS, O RINGS, FILTER SCREENS:	30 days
FILTER BAGS:	Not Covered by Warranty

Freezing of any one water or chemical related component will VOID all other implied warranty on all water or chemical related components, internal or external, of this equipment.

WARRANTY INFORMATION

To avoid misunderstandings which might occur between machine owners and manufacturer, we are listing causes of component failure that specifically voids warranty coverage. Such causes as listed below shall constitute **abuse or neglect**.

ENGINE: Operation at speed in excess of 2600 RPM. Failure to maintain proper oil level (oil should be checked every 5 running hours). Failure to use the proper oil viscosity and type (see engine manual). Use of other than manufacturer's recommended spark plug in engines. Failure to perform recommended maintenance as described on pages 3 and 4 of engine manual.

BLOWER: Failure to lubricate impellers daily with LPS-1 or WD-40 lubricant. Failure to lubricate bearings as recommended in blower manual. Failure to maintain proper oil levels in the blower. Failure to use the correct oil grade and viscosity as recommended in blower manual. Failure to properly maintain blower safeguard systems such as waste tank filter screen, vacuum safety relief valve in vacuum tank lid and waste tank automatic shut-off system.

HIGH PRESSURE WATER PUMP: Operation of pump at pressures over 1200 PSI. Failure to maintain proper oil level as recommended in pump manual. Failure to change oil in pump at recommended intervals. Failure to protect pump against freezing. Failure to maintain pump protection shut-off system. Failure to use water softener in hard water areas. Use of improper chemicals.

HEATER: Operation of heater without adequate water supply. Changing factory set propane regulator. Operating heater without proper ventilating. Failure to protect heater against freezing. Operating machine at water pressures over 1000 PSI. Overfilling of propane tank. Use of improper chemicals. Failure to use water softener in hard water areas.

VAC TANK: Failure to properly maintain filtering devices in tank. Failure to clean tank as recommended by manufacturer. Failure to maintain vacuum safety release in tank lid. Use of improper chemicals.

CHEM. PROPORTIONER: Use of improper chemical. Failure to use water softener in hard water area. Operating machine without proper chemical filter screen. Failure to protect against freezing.

CONTROL PANEL: Failure to protect flow meter and water pressure gauge against freezing.

VACUUM AND SOLUTION HOSES: Failure to protect hoses against freezing. Failure to protect hoses against burns from engine/blower exhaust. Damage to hoses from being run over by vehicles. Kinking or cracking from failure to store or unroll hoses correctly. Normal wear and tear from everyday use.

CLEANING WAND: Failure to protect against freezing. Obvious physical abuse of wand.

WARRANTY PROCEDURE

Warranty coverage is available to you **ONLY** through Hydra-Master Corporation, 20309 64th Ave. West, Lynnwood, Washington 98036; When warranty parts are needed, write **Hydra-Master Warranty Dept.** at the above address, or call the Warranty/Service Dept. at (206) 775-7275. **No collect calls will be accepted. Hours of the Warranty/Service Dept. are 8:00 - 11:30 am and 12:30 - 5:00 pm, Pacific Time.**

IMPORTANT

Hydra-Master's warranty policy provides replacement parts without charge for thirty (30) days to customers maintaining current account status. An invoice dated thirty (30) days from date of replacement

parts shipment will be sent to the customer for the amount of the parts sent. The customer's faulty parts **must be returned** for evaluation prior to the expiration of the thirty (30) day period. Upon warranty approval, a credit will be issued the customer for the replacement parts invoice. **Warranty disapproval or failure to return the faulty parts within the thirty (30) day period allowed will result in the customer being charged for the replacement parts sent.**

HOW TO ORDER

To obtain a proper diagnosis of your malfunction, and to order warranty replacement parts, it is important you follow the below procedure:

1. Call Hydra-Master Warranty/Service Dept. at (206) 775-7275
2. Give the Warranty/Service Representative the following information:
 - A. Name of your company and your address.
 - B. Equipment Model (i.e. Hydra-Cat, Bobcat 2, etc.)
 - C. Date of purchase.
 - D. Hours on the unit.
 - E. Serial number of unit.
 - F. Name of person authorized to order parts.
 - G. Salesman unit purchased from.
 - H. Description of malfunction.
 - I. Pressure readings on high pressure gauge with wand turned on and off.
3. If warranty replacement parts are needed, please specify method of shipment desired. **NOTE:** All replacement parts are sent **freight collect, via:**
 - A. U.P.S.
 - B. Air freight
 - C. Air mail
 - D. Air express
 - E. Auto Freight
4. Do not give malfunctioning parts to a Hydra-Master Sales or Service Representative. **All parts must be returned directly to Hydra-Master, freight prepaid.**

ONE FINAL NOTE:

Any questions you have regarding the warranty program should be directed to the Warranty/Service Dept. Personnel at Hydra-Master Corporation.

We shall always endeavor to be fair in our evaluation of your warranty claim, and shall provide you with a complete analysis of our findings.

PURCHASER'S RESPONSIBILITY

PRIOR TO ARRIVAL OF UNIT:

- Install $\frac{5}{8}$ " exterior plywood flooring in vehicle and cover with artificial turf.
- Have belly mounted propane tank installed on vehicle. Tank must be propane vapor type.

CAUTION

- Purchase heavy duty 42-60 amp hour battery and have battery 'slow' charged if new. If battery is not fully charged damage can occur to the engine charging regulator.

ACCEPTANCE OF SHIPMENT:

- If unit shows any outward signs of damage, do not sign the delivery receipt until you have closely inspected the unit and noted any damage on the delivery receipt. Have the freight company representative acknowledge the damage by signing the notation of damage on the delivery receipt.

READING OF OPERATION MANUAL:

- It is the purchaser's responsibility to read the unit operation manual and to familiarize himself with the information contained therein.

SALES REPRESENTATIVE RESPONSIBILITY

- The salesman from whom you purchased your unit is responsible for supervising the correct installation of the unit in your vehicle and thoroughly training you in its operation and maintenance.

CORRECT INSTALLATION INCLUDES:

Supervising the purchaser in the following:

- Installation of through-floor fittings for propane and gasoline fuel lines; installing propane regulator included with unit, **outside** vehicle; placing unit and recovery tank in vehicle and securing them with bolts or tie down cleats; connecting all propane and gasoline lines; connecting battery; checking pump, vacuum blower and engine oil levels, prior to starting unit; starting unit to check engine to see that all systems function normally; also checking all hoses, wands, etc., for correct operation.

TRAINING SHALL INCLUDE:

- Thorough review of the operation manual with purchaser; instruction and familiarization in: how to correctly start up and shut down unit; how to correctly clean with the unit; how, where and how often to check and change component oil levels; how the unit's systems work; how to troubleshoot the unit; how to do basic repairs; safety precautions and their importance; freezing damage and how to avoid it and a thorough review of the unit warranty and warranty procedures.

TRUCK PREPARATION

Manufacturer recommends the installation of plywood flooring covered with poly propylene backed astroturf (do not use rubber-backed) in the vehicle prior to installation of machine. This provides a metal to cushion mounting rather than metal to metal, provides insulation and makes an attractive van interior. Astroturf should be color keyed to van interior.

Materials Needed:

1. 2 sheets 4 x 8 x $\frac{5}{8}$ " exterior plywood
2. 6' x 12' piece of commercial astroturf
3. 16 - 1 $\frac{1}{2}$ " sheet metal screws
4. 1 quart marine adhesive (optional)
5. 1 staple hammer w/1 $\frac{1}{2}$ " staples

(See illustration for correct placement of plywood flooring)

PLACEMENT OF UNIT IN VEHICLE

There are two recommended unit placements:

A. **SIDE DOOR:** Most installations are side door. This provides rear access for accessories and hoses as well as unobstructed access to component/working side of machine, thus making it a bit easier to perform maintenance and/or repair without removing unit from the truck.

B. **REAR DOOR:** Although this location partly limits working access, it does direct the noise away from the cleaning site. Some cleaners in the colder areas prefer this location because it puts the weight mass over the rear wheels for better traction in ice and snow. Rear mounting requires the unit to be slid to the right side as far as possible. This not only provides adequate working space on the component side of the unit but also makes better weight distribution inside the van (engine and component weight line up over drive shaft). Also, it is physically easier to load unit into rear door due to height of van bed.

WARNING

Ensure that machine is well secured to the floor of van with hardware supplied. Sudden or crash stop will cause machine to rocket forward, all 350 lbs. worth! Protect yourself and the machine: **SECURE IT!**

TRUCK PREPARATION ILLUSTRATION

FIRST, cover the truck bed with $\frac{5}{8}$ " plywood using metal screws to secure it as shown.

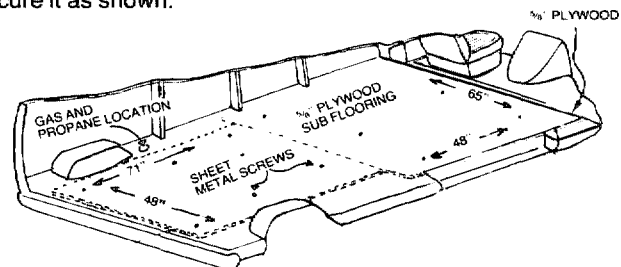

SECOND, select the appropriate color astro turf to match your van and cover the plywood and staple in place. A standard van requires a piece 6 feet by 12 feet.

THIRD, for added ventilation, an aluminum roof vent should be added over the location selected for mounting the machine. This will allow hot air from the heater to escape.

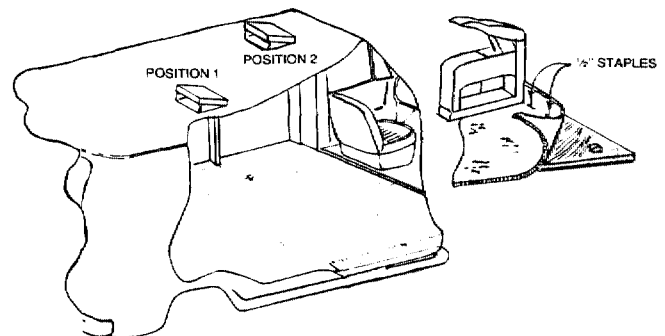

PROPANE TANK LOCATION

Either the 10 gallon or 16.5 gallon propane tank will fit this location. Have your local propane dealer install the tank you select and purchase. The machine will come with the proper propane regulator. (Tank must have vapor outlet).

WARNING Do not use a portable propane tank inside the truck or van. Besides being dangerous it is unlawful in most states.

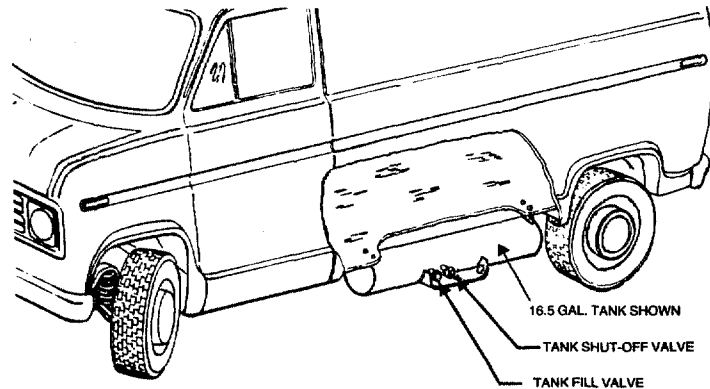

HARD WATER AREA MAP

The quality of water varies greatly throughout the United States and influences the reliability and efficiency of equipment in direct proportion to its level of hardness. The map below defines areas which compromise fluid related components such as hoses, fittings, heaters, pumps, valves and water cooled engines.

Cleaning efficiency and equipment life is increased, chemical use decreased and the appearance of cleaned carpets enhanced when water softeners are incorporated in hard water areas. Manufacturer strongly urges the use of water softener units in areas exceeding 3½ grains per gallon. Using the legend as a reference, determine the quality of water in your area and take action immediately should it be necessary.

(For installation diagram see machine installation section)

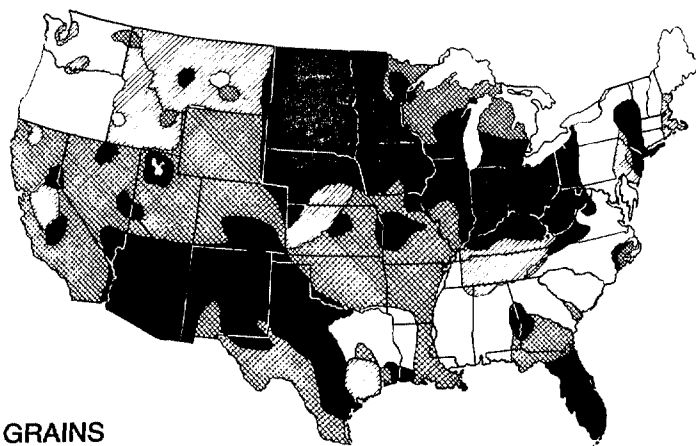

GRAINS PER GALLON

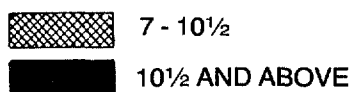
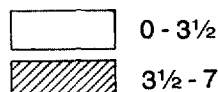

MACHINE SPECIFICATIONS

5

SPECIFICATIONS:

- FRAME:** 18" W, 46" L, 33" H. Steel With Baked-On Epoxy Finish.
- WEIGHT:** 325 Pounds.
- COWLING:** Steel With Baked-On Epoxy Finish.
- ENGINE:** 16 HP Briggs & Stratton Opposed Piston. Steel sleeved cylinders, ducted.
- IGNITION:** Magneto Key Start or Auxiliary Rope Start.
- HI-PRESSURE PUMP:** Tri-Plex Piston - Cat 290 - 3.5 GPM - 1200 PSI - @ 1200 RPM
- VACUUM BLOWER:** 3 MB Sutorbilt W/14 HG Safety Relief.
- CHEM. SYSTEM:** Auto Proportioning Flow Meter Controlled.
- HEATER:** Propane Fired, Thermostatically Controlled. (120,000 BTU).
- INSTRUMENTS:** 1-1000 High Pressure Gauge, Hour Meter, Chemical Flow Meter, Ignition Key Start.
- RECOVERY TANK:** 52 Gallon Aluminum Epoxy Finish.
- CLEANING WAND:** S/S 11" W/Heat Covered Handle - and Forward Guide Handle
- HI-PRESSURE HOSE:** ¼" High Temp Lined/Vinyl Covered Safety Orange W/Brass Quick Connects.
- VACUUM HOSE:** 2" Reinforced Safety Orange, 1½" Reinforced Safety Orange.
- STANDARD FEATURES:** Basic Console, 52 Gallon Vacuum Tank, 11" S/S Cleaning Wand, 100' ¼" High Pressure Hose, 90' - 2" Vacuum Hose, 10' - 1¼" Vacuum Hose, Battery Box, Through Floor Connections For Gasoline and Propane Hook-up, Tie-Down Cleats, Vacuum Hose Connections, Operation Manual.
- OPTIONAL FEATURES:** Stair Tool, Steel Legs W/Casters, Additional 2" Vacuum Hose in 50' Lengths, Additional ¼" Pressure Hose In 50' Lengths, Pressure Washing Gun, Spare Parts Package.

SPARE PARTS RECOMMENDATION

Because your truck-mounted unit is capable of generating several hundred dollars per day, down-time on the unit can be very expensive.

In order to minimize such down-time, it is strongly recommended by the manufacturer that you purchase and keep in your truck the following spare parts:

QUANTITY	PART NUMBER	DESCRIPTION
2		Engine Spark Plug
1	000-078-015	Flow Meter Kit
1	000-078-024	Wand Valve Plunger Kit
1	000-078-034	Press. Bypass Valve Kit
1	000-076-007	Spray Jet 8008E
2	000-049-028	Recovery Tank Filter Bag
1	000-078-001	Cat 290 Short Cup Kit Standard
1	000-078-004	Cat 290 Hot Cup Kit (Optional)
6	000-049-023	Screen Garden Hose
1	000-052-050	440 Male Quick Connect
1	000-052-051	440 Female Quick Connect
1	000-052-052	660 Male Quick Connect
1	000-052-053	660 Female Quick Connect
1	4 L 280	Belt, Pump Drive.

PARTS ORDERS

To expedite your parts needs, please call your sales representative. In most instances, he either stocks or has access to parts through a regional service center.

In the event parts are unavailable locally, contact the factory and coordinate your needs. If this becomes necessary, always indicate the method of shipment you desire, i.e. U.P.S., U.P.S. Blue Label, Air Freight, Air Express, etc..

Hydra-Master Parts Dept. phone (206) 775-7276.

WATER AND CHEMICAL FLOW OPERATION

This system has been designed to be the most simple and trouble-free ever.

The incoming water flows directly to the mix tank. Water will now flow through a proportioning valve which will simultaneously mix the chemical to achieve your desired solution. The mix tank is equipped with 2 different float valves, one of which responds to the water level of the tank and will maintain the proper volume of solution to be reserved for the cat pump. The secondary float valve is a safety valve that is designed to protect your system from sudden or unexpected loss of water supply. If, for example, the water source at the house was turned off, the water level of the mix tank would drop, activating the secondary valve which automatically kills the engine.

In conjunction with the incoming flow, the chemical ratio may be obtained by an adjustment of the chemical flow meter during the fill

cycle of the mix tank. The chemical will flow from the chemical jug to the chemical flow meter, then to the proportioner where it is distributed into the mix tank at your desired proportion. This line should be flushed with vinegar weekly to prevent abnormal chemical build-up. This may be done by removing the clear plastic hose from the chemical jug and inserting it into a one quart container of vinegar. This should be done with the chemical flow meter setting on 10 GPH with heater "off". Simply spray the wand for the duration of the vinegar in the one quart container, then repeat the process with one quart of clear water to void all lines of vinegar.

NOTE: with this unique chemical system, your chemical flow is proportioned to the filling cycles of the mix tank, not the direct spraying of the wand. Therefore, it is possible that as your wand is spraying, you may have no chemical flow. Also, the converse is true in that you may not be spraying your wand but, if the mix tank is in a filling cycle, your chemical flow meter may read your desired flow.

This chemical system will mix a 1 to 30 ratio when flow meter is set at 5 GPH. Most chemical suppliers will recommend a 1 to 15 ratio, therefore you can either set the flow meter at 10 GPH, giving you a 1 to 15 ratio of chemical to cleaning water, or double the recommended strength of chemical in the 5 gallon jug and set the flow meter at 5 GPH, thereby attaining a 1 to 15 ratio. (It is recommended that you set the flow meter at 10 GPH for overall best results.)

The water will now be siphoned from the bottom of the mix tank to the Cat Pump. If the wand is not spraying, the water will bypass from the bottom of the brass pressure relief valve to the mix tank.

If the wand is spraying, the water will then flow to the heater. This heater has a capacity of up to 2 gallons, therefore it is extremely important that all air is bled out of the heater prior to initial start-up. This may be achieved by running the system, without the heater on, for approximately 60 seconds.

WATER FLOW DIAGRAM BOB CAT 2/290 HYDRA CAT "S" SERIES

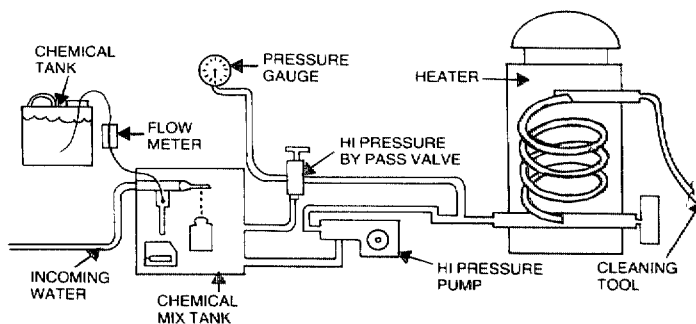

CHEMICAL FLOW DIAGRAM

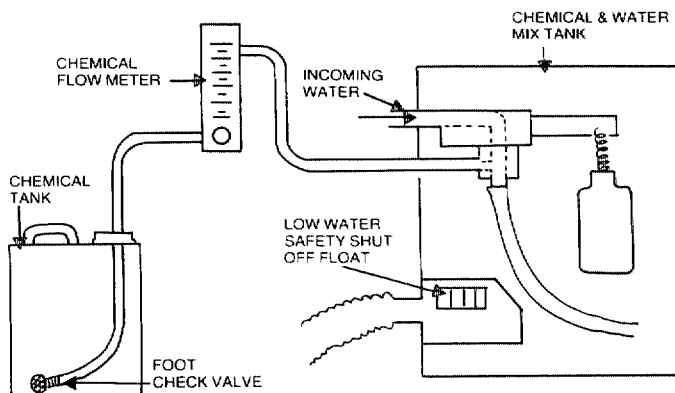

GENERAL INFORMATION FOR CAT PUMP REPAIR

As you remove your discharge manifold, there is a set of 3 check valves (which usually fall out during dis-assembly). If the surfaces of these check valves are dirty, or show signs of chemical build-up, it is probable that they would remain open causing pressure loss or pulsation. Upon inspecting the valves, make sure that the teflon buttons in the valve spring retainers are still intact. Also examine the discharge manifold. Look for problems such as cracks, chemical build-up or warpage due to freezing. If this discharge manifold is warped, it will cause the check valves to stick and will result in loss of pressure.

The Cat pump cups are often the source of pressure loss. Upon inspection they may appear melted or torn, but often they will look good. Replace them anyway. There is no sure method of visually inspecting the cups. Hydra-Master recommends changing cups whether they look good or not.

Anytime your pump is being dismantled, Hydra-Master recommends replacement of all 'o' rings and seals. This is merely a convenience to the customer to make sure that the Cat pump is in top operating condition.

The prrrm-a-lube seals located within the intake manifold will allow air to enter the pump if they are worn. Again, it is difficult to visually pinpoint a defective prrrm-a-lube seal. Replace them all.

Within the piston sleeve cylinders there are 6 'o' rings that are about 1/4 the size of a penny. If these 'o' rings are bad, water will be pumped back into the oil. If this has occurred the oil will raise in level and will appear milky. If you are unable to repair seals right away, change oil frequently. Repair the pump as soon as possible so as to not damage bearing or connecting rods.

Repairing of Cat pumps is not a difficult task. However, before disassembling make sure you have the proper parts required.

- 1 - short (or hot) cup kit
- 6 - piston sleeve 'o' rings
- 3 - Prrrm-a-lube seals
- 1 - bottle Cat oil

Read instructions thoroughly, supplied in the Cat pump manual, prior to disassembly and follow directions as stated. Oil all seals thoroughly prior to installation. (Remember, a newly scarred seal is no better than one you just took out.)

BYPASS VALVE ILLUSTRATION

TO SERVICE BYPASS VALVE

- Unscrew knurled knob and remove.
- Wiggle protruding shaft with fingers or pliers, pull up and remove from main body.

SPECIAL INSTRUCTIONS - BYPASS VALVE

- #4 - 5/16" fine thread
- #6 - Cup seal (if leather, replace or lube with leather oil).
- #7 - Brass bushing
- #8 - Shaft - if cup needs replacement, place thin end of shaft only in vise and remove 5/16" nut. Fat end is "seating" surface and must be free of abrasion to properly seat. **NOTE: IMPORTANT** -when replacing seals, only wrench nut #4 to where cup will not turn on shaft. If cup is too loose, bypass will leak. Too tight, cup will flange and bypass will leak.

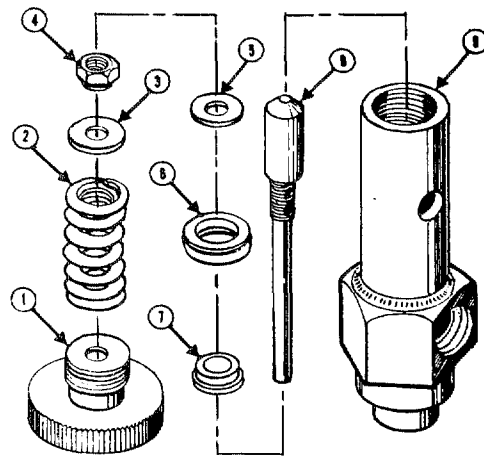

HIGH PRESSURE PUMP TROUBLESHOOTING

A pump instruction brochure on pages 8 - 15 may assist you in resolving a pump related problem.

PROBLEM:

● LOSS OF PRESSURE

CAUSE AND/OR SOLUTION:

1. **Clogged Filter Screen in garden hose quick connect coupler.**
 - A. Remove and clean or replace filter.
2. **Low water pressure at source.**
 - A. Determine rate of flow and select an alternate source of supply if water pressure is inadequate.
3. **Defective or blocked check valves in high pressure pump cylinder head.**
 - A. Disassemble cylinder head and replace or clean applicable check valve.
4. **Delaminated, kinked or clogged hose between the mix tank and the high pressure pump.**
 - A. Remove and replace defective hose.
5. **Defective pressure relief valve or debris in pressure relief valve.** NOTE: the high pressure bypass valve is designed to fully close when the cleaning tool is turned on. Any foreign matter collecting on the piston will prevent full closure of the valve and allow a portion of the water to continue to circulate instead of being routed to the cleaning tool. To correct this situation, the bypass valve must be disassembled and cleaned (refer to drawing provided in this manual for bypass disassembly).
 - A. Disassemble and clean pressure relief valve as illustrated in drawing.
 - B. Replace defective or worn out bypass cup.
 - C. Replace bypass valve.
6. **Defective or worn cups.**
 - A. Remove and replace piston cups as defined by pump manual.
7. **Loose drive belt for high pressure pump.**
 - A. Readjust belt as required or replace if defective.

WATER FLOW

1. **Worn out spray jet.** NOTE: Cleaning tools designed to spray a constant flow of 1 1/2 GPM will average 1 gallon of flow per minute in actual working situations since flow is not continuous. An average flow of 1 GPM results in 6000 gallons of flow for every 100 hours of unit operation. Spray tips are capable of constant flow rates for approximately 20,000 gallons. They should be replaced therefore, approximately every 350 hours. Worn spray jets allow a greater average rate of flow thus reducing desired temperature levels.
 - A. Remove and replace spray jet.

(Continued on Page 16).

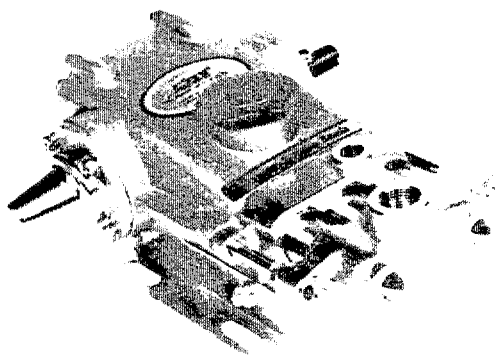

Model 290 OPERATING INSTRUCTIONS

CAUTION: CAT PUMPS are positive displacement pumps. Therefore, a properly designed pressure relief mechanism **MUST** be installed in the discharge piping. Failure to install such relief mechanism could result in personal injury or damage to the pump or system. Cat Pumps Corporation does not assume any liability or responsibility for the operation of a customer's high pressure system.

SPECIFICATIONS

	U.S. Measure	Metric Measure
Volume	3.5 GPM	(13 L/M)
Discharge Pressure	1200 PSI	(83 BAR)
Maximum Inlet Pressure	-8.5 to + 40 PSI	(-0.6 to + 2.8 BAR)
RPM	1200 RPM	(1200 RPM)
Bore	0.780"	(20mm)
Stroke	0.472"	(12mm)
Crankcase Capacity	10 oz.	(0.3 L)
Maximum Fluid Temperature	160°F	(71°C)
Inlet Port (1)	1/2" NPT	(1/2" NPT)
Discharge Port (2)	3/8" NPT	(3/8" NPT)
Pulley Mounting	Either Side	(Either Side)
Shaft Diameter	0.650"	(16.5mm)
Weight	12.1 lbs.	(5.5 kg)
Dimensions	10.6 x 9.1 x 5.7"	(268 x 230 x 146mm)

CAT PUMP WARRANTY

This Cat Pump ("product") is warranted by the manufacturer to be free from defects in workmanship and material for one year from date of manufacturer's shipment. This warranty is limited to repairing or replacing products which manufacturer's investigation shows were defective at the time of shipment by the manufacturer. All products subject to this warranty shall be returned F.O.B. Cat Pumps Corp., Minneapolis, Minnesota 55430, U.S.A. for examination, repair or replacement.

The express warranty set forth herein is in lieu of all other warranties, express or implied, including without limitation any warranties of merchantability or fitness for a particular purpose and all such warranties are hereby disclaimed and excluded by the manufacturer. Repair or replacement of defective products as provided above is the sole and exclusive remedy provided hereunder and the manufacturer shall not be liable for any further loss, damages or expenses, including incidental or consequential damages, directly or indirectly arising from the sale or use of this product.

This warranty is subject to the following warranty conditions:

IMPORTANT CONDITIONS

LUBRICATION — fill crankcase to dot on oil gauge window per specifications with Cat Pump oil or equivalent SAE 40 weight hydraulic oil with antiwear and rust inhibitor additives. Change initial fill after 50 hour run-in period. Change oil every three months or at 500 hour intervals thereafter. Prrrrrm-a-lube seals need no lubrication. Blue dot seals and wicks must receive three drops of Cat Pump oil per wick every 50 hours of operation.

GOOD LUBRICATION IS THE EASIEST, MOST EFFICIENT AND LEAST EXPENSIVE OF PREVENTATIVE MAINTENANCE.

RPM and PRESSURE — Pump operation must be within RPM and pressure specifications. Pressure relief valve must be installed.

DO NOT PUMP ACIDS OR ABRASIVE FLUIDS with this unit. Consult Cat Pumps for additional information on questionable fluids.

FREEZING CONDITIONS — Pump must be protected from freezing conditions.

USE OF OTHER THAN CAT PUMP PARTS OR THEIR EQUIVALENT VOIDS THE WARRANTY

Products described hereon are covered by one or more of the following U.S. patents 3558244, 3652188, 3809508, 3920356, and 3930756



P.O. Box 885 MINNEAPOLIS, MN 55440
Phone (612) 780 5440 • Telex 29 0276

N.V. CAT PUMPS INTERNATIONAL S.A.
Harmoniestraal 29
B-2060 Antwerp, Belgium

•
Loretohöhe 5
CH 6300, ZUG, Switzerland

•
CAT PUMPS DEUTSCHLAND GmbH
Rostocker Strasse 9
6200 Wiesbaden-Bierstadt
West Germany

•
CAT PUMPS (U.K.) LTD
17A Kings Road, Fleet
Hampshire GU13 9AA
England

Distributed By:

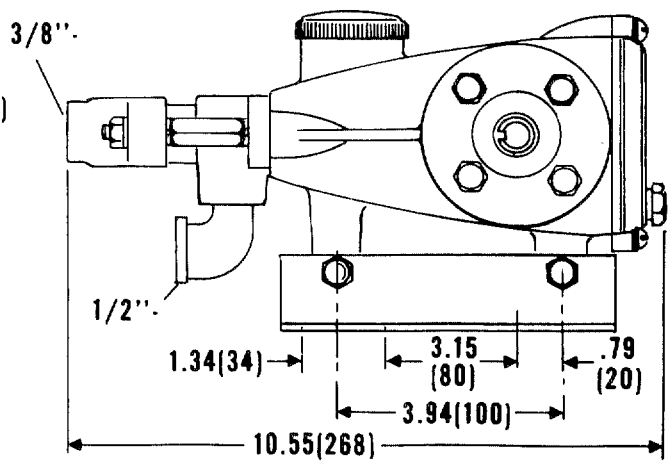
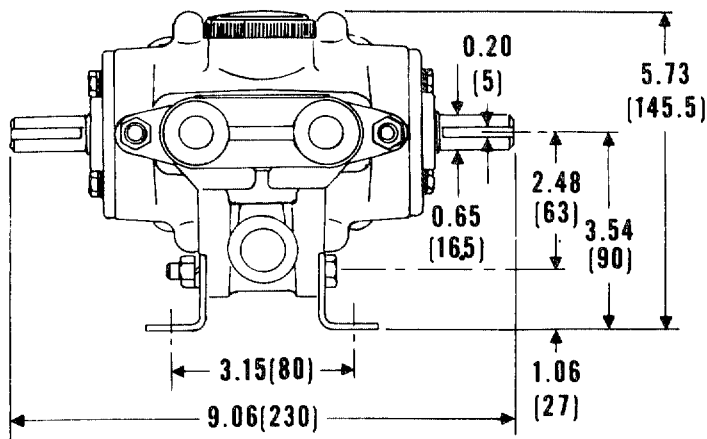

IMPORTANT DRIVE INFORMATION

HORSEPOWER REQUIREMENTS					Pulley Selection Using 5" Pump Pulley	
Flow		PRESSURE			RPM	Motor Pulley O.D.
		800 PSI	1000 PSI	1200 PSI		
GPM	L/M	55 BAR	69 BAR	83 BAR		
3.5	13	1.9	2.4	2.9	1200	3.5
3.0	11	1.7	2.1	2.5	1029	3.0
2.5	9	1.4	1.7	2.1	858	2.5

Pump speed and pump output in gallons per minute as tabulated is based upon a 1725 RPM drive motor. Select motor pulley size to provide GPM of the approximate pump output desired.

Pump RPM and GPM output are approximate values due to variations in pulleys, belts and motors between manufacturers and a + - 5% pump output tolerance.

Horsepower figures shown are brake horsepower figures. For gas engine requirements, follow engine manufacturer's recommendations. In general, use a gas engine with approximately double the electric motor horsepower.

TYPICAL INSTALLATION

The illustration at the right shows the basic elements for the proper installation of a high-pressure pump. Each component offers potential problems that too often are ascribed to a perfectly functioning pump. A clogged strainer, a partially closed shut-off valve or a faulty pressure gauge or pressure regulating unloader may be the source of trouble.

Proper system installation, routine lubrication and monitoring of components are your best and guarantees of optimum pump performance. These precautions will eliminate most problems, minimize corrective maintenance, and give many, many added hours of trouble free operation. Cat Pumps Corporation does not assume any liability or responsibility for the operation of a customer's high pressure system.

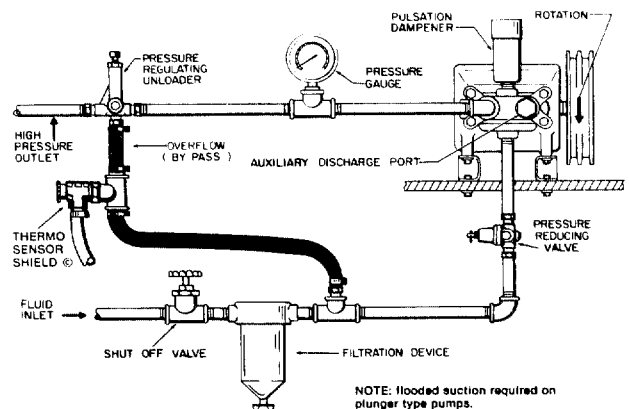

GENERAL INFORMATION

10

INTERPRETING PRESSURE READINGS: Pressure readings that differ from the rated PSI or those normal for a particular set-up indicate a problem, *but not necessarily a pump problem!*

Before any servicing of the pump, carefully check the following; inlet plumbing for size, restriction and/or air leaks, restricted or worn orifice and condition of the by-pass valve and pressure gauge. Check any shut-off valves in the inlet or discharge plumbing to be sure they are fully open. Seven out of ten problems are other than pump problems!

FOR SERVICE contact your local representative or look in the Yellow Pages under **PUMPS**.

ORDERING OF PARTS: When ordering parts, be sure to give the "model number" and "serial number", "description", and "quantity" of the items desired.

MATERIAL RETURNS: If necessary to return a Cat Pump, please secure an approved "RETURN GOODS AUTHORIZATION" form from Cat Pumps Corporation and complete a "PRODUCT REPORT" form detailing the application and the conditions of operation. Any material AUTHORIZED for return must be shipped **FREIGHT PREPAID**.

FILTER INSPECTION: A frequent source of low pressure is due to foreign matter in the fluid being pumped. It takes but one small particle to partially hold open a valve—several to plug an inlet screen or filter, or if the particles are abrasive, to damage packings, valves, valve seats, or plungers.

Inspect filters and screens on a schedule commensurate with the material being pumped and whenever a low pressure problem develops.

NOZZLES: A worn nozzle will result in loss of pressure.

INSTALLATION

Optimum performance of the pump is dependent upon the entire fluid system and will be obtained only with the proper selection and installation of plumbing and accessories.

Lubrication: Fill crankcase with oil as covered under warranty conditions.

Pulley Selection: Select size of motor pulley required to deliver the desired volume from Horse Power Requirement and Pulley Selection Chart.

Motor Selection: The motor or engine driving the pump must be of adequate horsepower to maintain full RPM when the pump is under load. Select a motor from the Horse Power Requirement Chart according to required pump discharge volume and maximum pressure *at the pump!*

Mount the pump on a rigid, horizontal surface in a manner to permit drainage of crankcase oil. An uneven mounting surface will cause extensive damage to the pump base. Use the correct belt; make sure pulleys are aligned. Excessive belt tension may be harmful to the bearings.

Inlet Plumbing must be at least the same diameter as the inlet port, preferably one size larger. Restriction in the inlet plumbing will cause cavitation in the pump, drastically reducing packing life. All joints must be air tight.

Inlet Pressure: Optimum performance is obtained with +20 PSI inlet pressure. With adequate size inlet plumbing, the pump will perform very satisfactorily with

flooded suction. The pump can operate with inlet pressure up to 40 PSI. Use of excessive pressure will void the warranty.

Inlet Accessories: Install an inlet strainer of twice the rated capacity of the pump.

A stand pipe to help maintain a positive pressure head in the inlet line is desirable.

A shut-off valve is recommended to facilitate maintenance.

Discharge Plumbing: *Install a pulsation dampening device* mounted directly to the discharge line and precharged to a pressure calibrated for operating conditions.

A reliable pressure gauge should be installed near the discharge outlet of the high pressure manifold. This is extremely important for adjusting pressure regulating devices and also for proper sizing of the nozzle or restricting orifice. The pump is rated for a maximum pressure; this is the pressure which would be read at the discharge manifold of the pump, not at the gun or nozzle end of a long hose.

A pressure regulating relief valve or unloader must be installed to prevent over-pressure in the event the discharge or downstream plumbing becomes plugged or is turned off. Severe damage to the pump will result if this condition occurs without a relief valve in the line. **CAUTION:** Failure to install such a valve will void the warranty on the pump.

EXPLODED VIEW MODEL 290

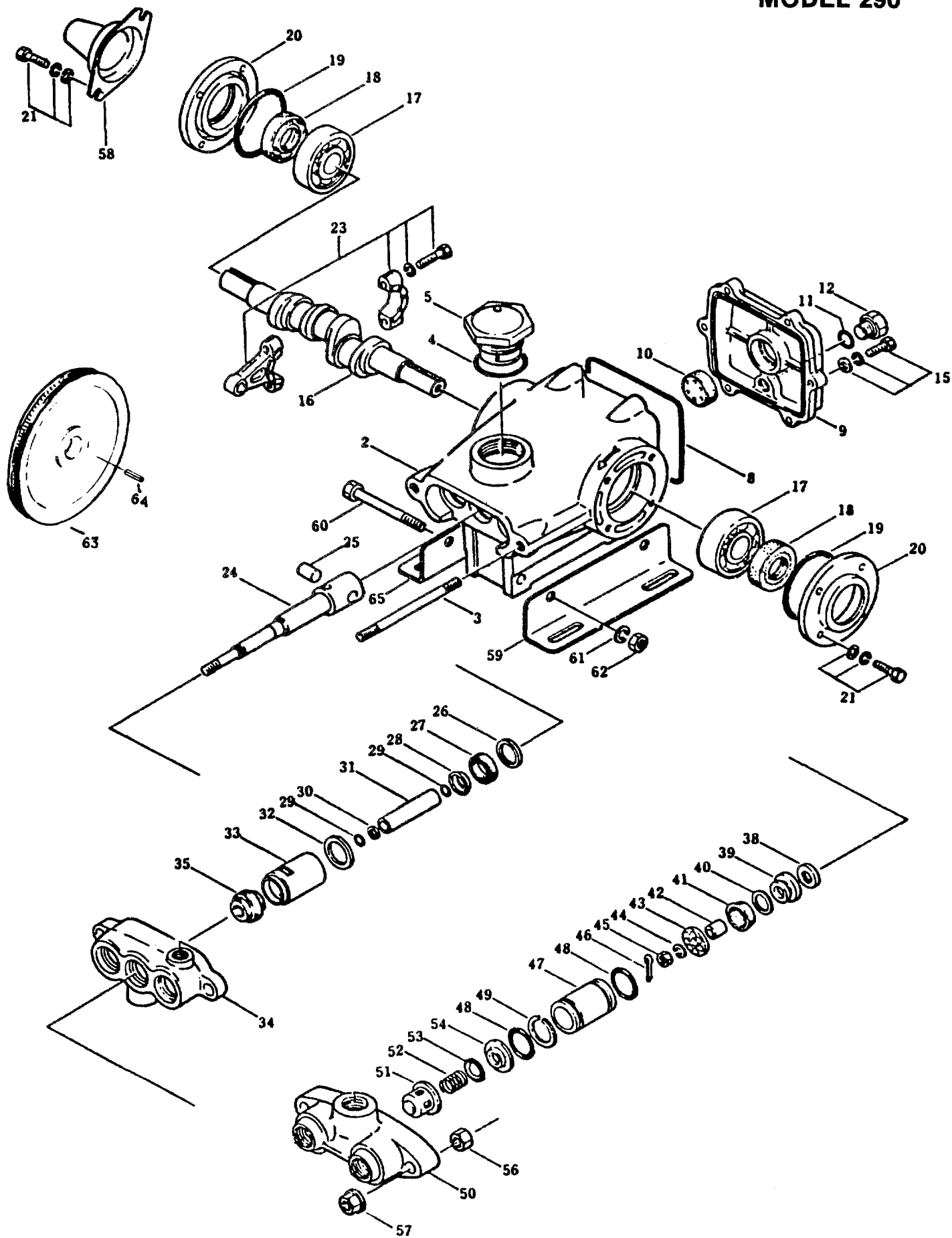

PARTS LIST CAT PUMP MODEL 290

ITEM	PART NO	DESCRIPTION	QTY.	ITEM	PART NO.	DESCRIPTION	QTY.
2	28766	Crankcase	1	38	27004	Inlet Valve	3
3	85680	Stud (M8 x 82)	2	39	30543	Bac-Cup Piston	3
4	14177	O-Ring, Oil Filler Cap	1	40	30544	Bac-Cup Ring (Teflon)	3
5	43211	Oil Filler Cap	1	41	43172	Cup (Viton)	3
8	26087	O-Ring,Crankcase Cover	1	42	27983	Piston Spacer	3
9	26105	Crankcase Cover	1	43	27002	Piston Retainer	3
10	22289	Oil Gauge	1	44	27006	Conical Washer-SS (M6)	3
11	23170	O-Ring, Drain Plug	1	45	18956	Nut-SS (M6)	3
12	25625	Drain Plug	1	46	14158	Cotterpin	3
15	92520	Sems Comb Head Screw (M6 x 20)	6	47	101802	Cylinder(43834 Unch)	3
16	43804	Crankshaft	1	48	23172	O-Ring, Cylinder	6
17	14487	Rearing	2		11377	O-Ring, Cylinder (Viton)	6
18	24159	Oil Seal	2	49	21985	Bac-Up Ring, Cylinder	3
19	26536	O-Ring, Oil Seal Case	2	50	24459	Discharge Manifold	1
20	27950	Oil Seal Case	2		25634	Discharge Manifold- Stainless Steel	1
21	92519	Sems Comb. Head Screw (M6 x 16)	8	51	43442	Valve Spring Retainer	3
23	101799	Connecting Rod	3	52	43360	Valve Spring	3
24	101800	Piston Rod	3	53	43723	Valve	3
25	16948	Piston Pin	3	54	43434	Discharge Valve Seat	3
26	20017	Seal Washer	3	56	81109	Hex Nut (M8)	2
27	25301	Oil Seal	3	57	101804	Hex Flange Nut (M8)	2
28	25327	Barrier Slinger	3	58	25130	Shaft Protector	1
29	25392	O-Ring, Sleeve	3	59	26246	Angle Rail	2
	28771	O-Ring, Sleeve (Viton)	3	60	30901	Hex Cap Screw (5/16 x 2 3/4)	2
30	29003	Back-Up Ring, Sleeve	3	61	30920	Split Lockwasher (5/16 US)	2
31	29614	Sleeve (29743 Unchromed)	3			30612 Angle Mounting	2
32	26854	Seal Washer	3	62	30910	Hex Nut (5/16 US)	2
33	28597	Seal Retainer	3	63	30032	Pulley 5" w/2 Set screws	1
34	25128	Inlet Manifold	1	64	30047	Key (M5)	1
	25635	Inlet Manifold-Stainless Steel	1			30246 Pulley Asbly.	1
35	30315	Prrrrrm-A-Lube Seal	3				
	30325	Prrrrrm-A-Lube Seal(Viton)	3				

SERVICE KITS

30023 Cup Kit

3	Cup
6	O-Ring, Cylinder
3	Cotterpin
1	Instruction Sheet
1	Cup Inserter

30305 Seal Kit

3	Prrrrrm-A-Lube Seal
3	Cotterpin
2	Abrasive Paper
1	Instruction Sheet

30431 Sleeve and Seal Kit

3	Prrrrrm-A-Lube Seal
3	Barrier Slinger
3	Cotterpin
3	Sleeve
6	O-Ring, Sleeve
1	Instruction Sheet

30686 Valve Kit

3	Valve Spring Retainer
3	Valve Spring
3	Valve
3	Valve Seat
3	O-Ring, Cylinder
1	Instruction Sheet

30860 Piston Kit

6	O-Ring, Cylinder
3	Back-Up Ring,Cylinder
3	Bac-Cup Piston
3	Bac-Cup Ring
3	Cup
3	Piston Spacer
3	Piston Retainer
3	Conical Washer (M6)
3	Nut (M6)
3	Cotterpin
3	Inlet Valves
1	Instruction Sheet

SERVICING DISCHARGE VALVES & VALVE SEATS

13

DISASSEMBLY

1. Loosen the 2 (M8) locking nuts approximately one turn.
2. Then remove the 2 (M8) flange nuts.
3. Grasp the discharge manifold with 3 fingers on the underside and tap with a soft mallet to remove
4. Valve assemblies will remain with the manifold. Invert manifold and discharge valve assemblies should fall out.
5. Inspect discharge valves for wear or ridges. (Spherical valves due to their shape must be replaced when worn.)

REASSEMBLY:

1. Place retainer in manifold chamber.
2. Next insert spring into center of retainer
3. Place valve over spring with spherical (mooned) side down.
4. Next insert the valve seat.
5. Position manifold back onto pump. NOTE: *Exercise caution when inserting cylinders into manifold to avoid damaging cylinder o-rings.*
6. Replace flange nuts on studs and hand tighten both sides. Then torque each side to 125 inch pounds.
7. Hand tighten locking nut.

CAUTION: *When restarting the pump, check to see that there is no cylinder motion as this will cause premature failure of the cylinder o-rings. Center cylinder motion can be eliminated by switching with one of the end cylinders.*

SERVICING THE PUMPING SECTION

DISASSEMBLY:

1. Remove discharge manifold as described above.
2. Slip cylinders out of inlet manifold.
NOTE: *Identify cylinders so they will be replaced in their original position. (Front to back)*
3. Remove cotterpin, nut, and washer.
4. Next remove piston retainer, spacer, and piston assembly.
5. Remove inlet valve.

SERVICING THE SEALS AND SLEEVES

14 REASSEMBLY:

1. Examine inlet valve surface and reverse if damaged. (both sides are lap surfaces.)
2. Examine piston assembly for clean inlet surface. If damaged, replace and lubricate.

NOTE CUP INSTALLATION:

Wipe cup inserter lightly with oil. Slip bac-cup ring onto piston. Force cup over inserter and square with all surfaces. Faulty cup installation causes premature failure.

3. Next replace piston spacer and retainer.
4. Slip washer onto rod, screw on nut and torque to 60 inch pounds. **NOTE: ALWAYS REPLACE WITH NEW COTTERPIN.**
5. Examine cylinder walls for scoring or etching. These conditions will cause premature wear of your piston assemblies. replace if worn or damaged.
6. Lubricate cylinder and replace o-rings and back-up rings (if defective).
7. Position cylinders in their original order into manifold chambers and carefully slip over rod ends onto the pump.
8. Replace flange nuts on studs and hand tighten both sides. Then torque each side to 125 inch pounds.
9. Hand tighten locking nuts.

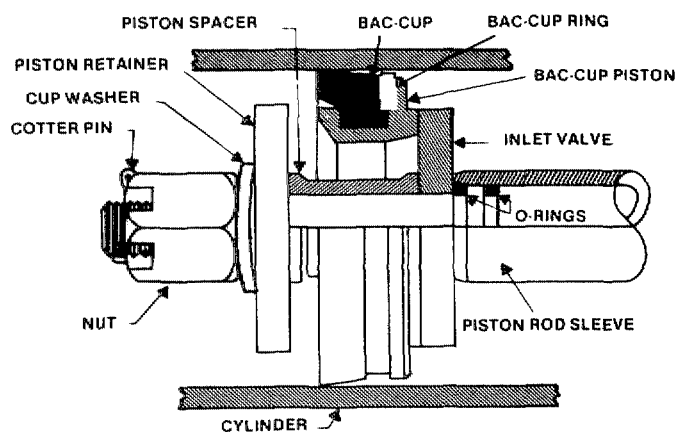

PUMPING SECTION CUTAWAY

DISASSEMBLY:

1. Remove discharge manifold and piston assemblies as described.
2. Remove both (M8) locking nuts from studs
3. With soft mallet, tap inlet manifold loose from crankcase.
4. Place inlet manifold on pair of clearance blocks with crankcase side down. and drive out seals.
5. Invert inlet manifold with CRANKCASE SIDE UP.
6. Lubricate circumference of new Prrrrm-A-Lube seals, position in manifold with GARTER SPRING DOWN and drive into place.
7. Examine sleeves for scoring or other damage before removing
8. If worn, grasp sleeve with pliers and pull off. **NOTE: This procedure will mar the sleeve so use only if sleeve is to be replaced.**
9. Remove o-ring and back-up rings from piston rod.

REASSEMBLY:

1. Place barrier slinger on rod.
2. Lubricate new o-rings and back-up rings. Install first o-ring in the o-ring groove on the piston rod. Position back-up ring against the shoulder in front of the first o-ring, then the second o-ring. Be careful to avoid damaging the o-rings when slipping them over the piston rod threaded ends.
3. Immerse sleeve in oil carefully twist and push onto rod. (machined counter bore end first).
4. Replace seal retainers.
5. Exercise caution when replacing inlet manifold, so the inlet seals are not damaged by the threaded rod ends.
6. Replace locking nuts on studs.
7. Reassemble piston assemblies and discharge manifold as described.

Consult factory for your local distributor for crankcase servicing.

DIAGNOSIS AND MAINTENANCE

PROBLEM	PROBABLE CAUSE	SOLUTION	PROBLEM	PROBABLE CAUSE	SOLUTION
Pulsation	Faulty Pulsation Dampener	Check precharge; if low recharge it or install a new one	Excessive play in the end of the crankshaft pulley	Worn main ball bearing from excessive tension on drive belt	Replace ball bearing. Properly tension belt.
Low Pressure	Worn nozzle	Replace nozzle, of proper size	Water in crankcase	May be caused by humid air condensing into water inside the crankcase	Change oil at 3 month or 500 hour intervals using Cat Pump Crankcase Oil (other approved oil every month or 200 hours) P.N. 06100.
	Belt Slippage	Tighten or replace; use correct belt		Leakage of manifold inlet seals and/or piston rod sleeve O-ring	Replace seals, sleeve and O-rings.
	Air leak in inlet plumbing	Disassemble, reseal, and reassemble	Oil leaking from underside of crankcase	Worn crankcase piston rod seals	
	Pressure gauge inoperative or not registering accurately	Check with new gauge; replace worn or damaged gauge, P.N. 06090	Oil leaking at the rear portion of the crankcase	Damaged or improperly installed oil gauge or crankcase rear cover O-ring, and drain plug O-ring	Replace oil gauge or cover O-ring, and drain plug O-ring
	Relief valve stuck, partially plugged or improperly adjusted; valve seat worn	Clean, and adjust relief valve; check for worn and dirty valve seats. Kit Available.	Oil leakage from drain plug	Loose drain plug or worn drain plug O-ring	Tighten drain plug or replace O-ring
	Inlet suction strainer clogged or improper size	Clean. Use adequate size. Check more frequently.	Loud knocking noise in pump	Pulley loose on crankshaft	Check key and tighten set screw.
	Worn piston assembly Abrasives in pumped fluid or severe cavitation. Inadequate water supply.	Install proper filter. Suction at inlet manifold must be limited to lifting less than 20 feet of water or - 8.5 PSI vacuum.	Frequent or premature failure of the inlet manifold seals	Broken or worn bearing	Replace bearings
	Fouled or dirty inlet or discharge valves	Clean inlet and discharge valve assemblies.		Scored rods or sleeves	Replace rods and sleeves.
	Worn inlet or discharge valves	Replace worn valves, valve seats and/or discharge hose.	Short cup life	Over pressure to inlet manifold	Reduce inlet pressure per instructions
	Leaky discharge hose			Damaged or worn chrome plating of the cylinders	Replace cylinders
Pumps runs extremely rough, pressure very low	Restricted inlet or air entering the inlet plumbing	Proper size inlet plumbing; check for air tight seal		Abrasive material in the fluid being pumped	Install proper filtration on pump inlet plumbing
	Inlet restrictions and/or air leaks. Damaged cup or stuck inlet or discharge valve	Replace worn cup or cups, clean out foreign material, replace worn valves		Excessive pressure and/or temperature of fluid being pumped	Check pressures and fluid inlet temperature; be sure they are within specified range
	Worn inlet manifold seals	Replace worn seals.		Over pressure of pumps	Reduce pressure
	Worn inlet seals allow pump to draw air.	Install new inlet manifold seals.	Running Pump dry	Do not run pump without water	
Cylinder O-rings blown next to discharge manifold	Pressures in excess of rated PSI	Check for plugged nozzle, closed valves or improperly adjusted by-pass valve	Front edge of piston sharp	Replace with new piston	
	Warped manifold	Replace manifold	Chrome plating of cylinders damaged causing excessive wear of cups. May be caused by pumping acid solution.	Install new cups and cylinders. Pump only fluid compatible with chrome	
Leakage at the cylinder O-rings at the discharge manifold and black, powdery substance in the area of the O-rings	Loose cylinders. Cylinder motion caused by improper shimming of the discharge manifold	Remove spacer shims on manifold studs. Do not remove too many shims or the ears of the manifold will be bowed when the manifold is retightened, causing looseness in the center cylinder	Strong surging at the inlet and low pressure on the discharge side	Foreign particles in the inlet or discharge valve or worn inlet and/or discharge valves	Check for smooth lap surfaces on inlet and discharge valve seats. Discharge valve seats and inlet valve seats may be lapped on a very fine oil stone; damaged cups and discharge valves cannot be lapped but must be replaced.
Water leakage from under the inlet manifold	Worn inlet manifold seals. Leaking sleeve O-ring	Install seals. If piston rod sleeves are scored, replace sleeves and sleeve O-rings.			
Oil leak between crankcase and pumping section	Worn crankcase piston rod seals	Replace crankcase piston rod seals			
	Excess oil from wicks	Reduce quantity of oil per oiling			
Oil leaking in the area of Crankshaft	Worn crankshaft seal or improperly installed oil seal retainer packing	Remove oil seal retainer and replace damaged gasket and/or seals			
	Bad bearing	Replace bearing			

2. Reduction of Flow.

A. Due to increased length of solution hose.

NOTE: for every 50 feet of hose, beyond 100 feet in total length, a measurable loss of flow is experienced. This condition is a result of the increased friction experienced by the water as it passes through the hose. Therefore, it is necessary to increase the pressure at the machine 40 PSI for every additional 50 feet of cleaning solution hose over 100 feet.

CHEMICAL PROPORTIONING AND LEVEL CONTROL ILLUSTRATION

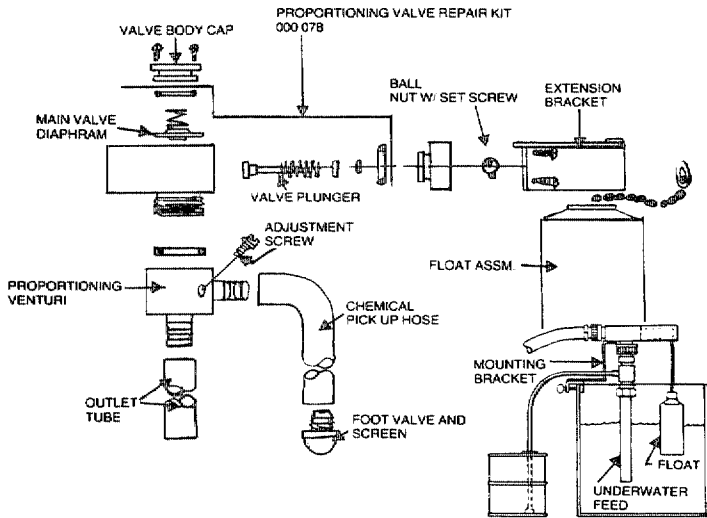

CHEMICAL TANK TROUBLESHOOTING

NO OR LOW CHEMICAL FLOW

1. Check that hoses in the tank are secured. Check that the hose from the top of the flow meter to the side of the mix tank is secured with no kinks. Check the hose from the bottom of the flow meter to the chem. Jug for kinks or cracks.
2. Check the foot valve and screen on the end of the hose which goes into the mix tank. To check this screen for proper function, remove it from the plastic hose. You should be able to suck through the hose barb end, but you should not be able to blow through the hose barb end. (If you can not suck through it then rinse it out with vinegar). When screen is removed the chemical fuel hose should be lifted into a vertical position so the ball in the foot valve will seat by gravity. (This is only a temporary fix for low water pressure areas.)
3. Check flow meter for float obstruction.
4. Check to insure that the adjusting screw on proportioning venturi is backed out.
5. Is proportioning venturi closed? Soak in warm water or vinegar solution.
6. Is incoming water pressure less than 20 PSI.?
7. Cracked or defective chemical flow meter?

NOTE: If you are in a low water pressure area and find that the volume of water entering the mix tank is not enough to allow your venturi to siphon chemical, unscrew the spring from the foot valve screen and remove the spring.

INABILITY TO ADJUST CHEMICAL WITH THE FLOW METER

1. Debris lodged behind teflon seat in flow meter knob.
2. Teflon seat dismounting from flow meter knob.

SOLUTION REVERSING FROM MIX TANK TO CHEMICAL JUG

1. Anti-siphon screen removed from chemical jug hose.
2. Debris in anti-siphon screen.

MIX TANK OVERFLOWS

1. Float ball in mix tank hanging up (not moving freely).
2. Extension bracket pinching the float lever, restricting full action of the lever.
3. Plunger not seating properly on the valve. (Remove the 2 screws which hold the extension assembly to the valve. Do not lose or drop the screws. Remove the extension assembly. Turn it upside down. Inspect the plunger for proper seating. If there is no debris obstructing the valve or plunger, the plunger may be out of adjustment. To adjust, loosen the set screw on the ball nut and move the ball toward the end of the rod 1/16". Retighten set screw. Place extension assembly back into position. Tighten the two screws.

MIX TANK DOESN'T KEEP UP WITH WATER OUTPUT

1. Check garden hose quick connect assembly screen.
2. Check garden hose and/or feed hose to the mix tank for clog, kinks or blockage.
3. Float ball in mix tank hanging up. (Not moving freely).
4. Extension bracket pinching float lever, restricting full action of lever.
5. Valve plunger not opening fully. To adjust, remove the 2 screws which hold the extension assembly to the valve. (Do not lose or drop the screws). Remove the extension assembly, turn it upside down. To adjust, loosen the set screw on the ball nut. Place your thumb on the plunger and press it in 1/16" and slide the ball nut w/ set screw toward the plunger end 1/16". Tighten the set screw. Place the extension assembly back into position. If the tank starts to overflow, the ball nut is too close to the valve plunger and should be moved back away from the valve plunger slightly.

PUMP PULSATES WHEN THE TANK IS IN A FILL MODE

1. Check that the hose which goes from the gray plastic venturi to the bottom of the tank is not directed toward the Cat pump pick up port. If it is, aim it in another direction.

HEATING SYSTEM INFORMATION

The propane heater incorporated in this equipment is of special design for use in the carpet cleaning industry. It's high pressure coils and thermostatic temperature control make it simple to operate and reliable. Once the desired temperature is set, the heater will then go 'on' and 'off' according to the water temperature within the heater. As water is used through the cleaning tool, cold water entering the heater will activate the thermostatically controlled propane valve thereby firing the heater to maintain a consistent flow of hot water. Once the cleaning wand is shut off and the flow of water through the heater stops, the heater will continue to burn until the set temperature is attained.

It is possible then with this design that the flame may be on when the wand is off, likewise, it is possible the flame may be off when the wand is on.

CAUTION

This heater is designed to burn vapor propane gas only. Any liquid propane entering the heater may cause damage to the control valve on the heater. It will also cause improper burning and a soot build-up on the coils. Therefore, it is necessary to shut off the heater and close the valve at the tank between cleaning locations. Failure to do this allows sloshing liquid to enter the vapor feed line to the heater.

Overfilling of the propane tank will cause many problems. To avoid this, advise the attendant filling the tank **not to fill the tank over 80%**. When filling the tank, watch the 10% valve and immediately

stop filling when white liquid starts spurting from the 10% valve. To prevent damage to the propane regulator, always close the valve on the tank before filling.

When venting the heater through the roof of the van, it is necessary to install a draft diverter on top of the heater. This will prevent down drafts from blowing out the pilot light.

The propane regulator is pre-set at the factory at 6 oz. of propane. This reading is taken at the control valve on the heater (see figure A #6). To prevent road dust and moisture from entering the propane regulator, keep the white tupperware cover (supplied) on the regulator at all times.

To avoid restriction of air flow at base of heater, keep articles such as chemical containers, hose, boxes, etc. from within 18 inches of base of heater. **NOTE:** This restricted situation also creates an over rich condition which results in soot build-up.

IMPORTANT: If a new propane tank has been installed or hoses have been disconnected, air may enter propane hoses and must be purged prior to attempting to light the pilot burner. Should this condition exist, operator must depress the pilot button for 1 - 5 minutes and attempt to ignite the pilot light at 15 second intervals. A very slight hissing noise should be evident while performing this operation.

HEATER - OPERATING INSTRUCTIONS

CAUTION Heater must be filled with water prior to igniting.

A. TO START PILOT:

1. Adjust thermostat control knob on unitrol to 'normal'. ③ Fig. A.
2. Adjust upper dial to 'pilot' position. ① Fig. A.
3. Depress pilot button. ② Fig. A.
4. While pilot button is depressed with the left hand, use your right hand forefinger to depress the electric spark pilot ignitor button several times in rapid succession, then look to see if pilot is lit. If not, depress in rapid succession again until lit. If this fails, use the resourceful match.

NOTE: Whenever igniting pilot, hold lit match in front of pilot sight opening before inspection. Move lit match toward pilot burner. The pilot should ignite.

CAUTION Always keep face away from main burner opening to avoid ignition flash burn.

IF HEATER FAILS TO LIGHT:

- Is propane tank full?
- Is propane tank valve open?
- Has air been properly bled from propane line?
- Once pilot is lit continue depressing button for 10 seconds to insure thermo coupler has been heated.

B. TO LIGHT MAIN BURNER:

1. Turn upper knob to 'on' position. Flame will come on.

IF NOT: Pilot has expired.

- Turn upper dial to 'off' position. ① Fig. A.
- Do not attempt to relight pilot for 60 seconds.
- Then repeat instructions A - #1-4.
- Water may already be at controlled temperature.

IF YES: Flame will turn off when thermostat senses maximum temp.

C. TO ACHIEVE PROPER CARPET CLEANING TEMPERATURE:

1. Complete procedures A & B
2. With 100' of hose, turn cleaning wand on for 5 minutes and the temperature should stabilize.
3. Once a constant temperature is established, turn cleaning wand 'off'. The flame on the heater burner should remain on for 10 - 15 seconds.
 - A. If the flame expires prior to 10 seconds, turn the thermostat dial to a higher reading, then repeat C 1 - 3.
 - B. If the flame remains lit after 15 seconds, turn the thermostat dial to a lower reading, then repeat C 1 - 3.

D. TO SHUT DOWN HEATER:

1. Turn upper dial to 'off' position. ① Fig. A.

CAUTION

2. Turn cleaning wand on for 3 to 5 minutes to cool heater core. If heater core is not cooled, it is impossible that the heat retained in the core will cause boiling back into the chemical mix tank.
3. Close propane tank valve while wand is on and heater is cooling.

PILOT BURNER ADJUSTMENT

1. Remove pilot adjustment cap ⑤
2. Adjust pilot key to provide properly sized flame
3. Replace pilot adjustment cap

ALLEN HEAD PIPE PLUG ⑥ CAN BE REMOVED FOR MONOMETER INSERTION TO READ PROPANE OUNCES.

FIG. A

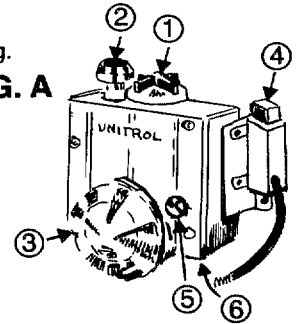

HEATER TROUBLESHOOTING

- EXCESSIVE HEAT
- FLAMES PROTRUDING OUTSIDE THE LOWER OPENINGS

CAUSE AND/OR SOLUTION:

1. Thermostatic control dial set too high
 - A. Turn dial to lower setting
2. Maladjustment of propane regulator. **NOTE:** Propane regulators are factory preset and may be readjusted by authorized personnel.
 - A. Contact manufacturer to determine correct procedure.
 - B. Have your local propane dealer use a monometer at the unitrol to re-set the propane regulator to 7 oz. maximum.
3. Overfilled propane tank. **NOTE:** Propane heater is designed to operate on vapor propane only. Over-filling a propane tank allows liquid propane to enter all heater related components and permits an over-rich burning condition to occur. This condition usually requires the heater core to be cleaned of soot and carbon deposits. Cleaning is a messy, dirty job and very inconvenient, so don't let it happen to you!

PROBLEM:

- PILOT LIGHT

CAUSE AND/OR SOLUTION:

1. Pilot light will not ignite. **NOTE:** Do not use a needle or pin to clean pilot orifice - use compressed air or solvent only.
 - A. Verify propane reaching ignitor. **NOTE:** A kinked or crushed hose may impede propane flow.
 - B. Remove and clean orifice.
 - C. Verify ignitor spark is operating correctly.

VACUUM SYSTEM INFORMATION

The vacuum blower incorporated in this machine is a positive displacement lobe type, manufactured by Fuller Company. The performance and life of this unit is greatly dependent on the care and proper maintenance it receives.

Because of the close tolerances between the lobes and housing of the vacuum blower, solid objects entering the inlet will damage the internal lobes, gears and bearing or direct drive coupler.

To prevent this, a stainless steel filter screen has been placed at the vacuum inlet inside the vacuum recovery tank. This stainless steel screen is finger tight and should be removed for cleaning weekly.

CAUTION

Should be used when machine is being run for test purpose and the vacuum inlet on top of machine is open.

To protect the vacuum blower from over loading and damaging itself, there is a vacuum relief system installed on the vac tank lid. When the vacuum tank inlet is completely sealed off, a maximum of 14 HG will be attained. A hole on the top blower pipe elbow acts as the lubrication point; at the end of each day, LPS 1 or WD-40 is sprayed in before shutting down the machine. See blower lubrication illustration. If you fail to lubricate the vacuum blower daily, rust deposits and moisture will decrease the life of the vacuum blower.

Read the vacuum blower manual carefully for proper oil change and grease application. The maintenance log may differ slightly from the manual, but the truck-mounted carpet cleaning machine application is very demanding of the vacuum blower and therefore it should be maintained more regularly.

VACUUM TANK FILTER BAGS

Hydra-Master filter bags are designed to trap all of the lint, sand and dirt that would normally collect at the bottom of your vacuum tank. The use of these bags, if emptied at the end of each job, will eliminate the build-up of much of the debris in the tank and avoid a mess on the customer's driveway or street. The drawstring top of these bags is designed to be tied to the incoming dirty water inlet in the vacuum tank.

To re-order bags use part number **049-028**

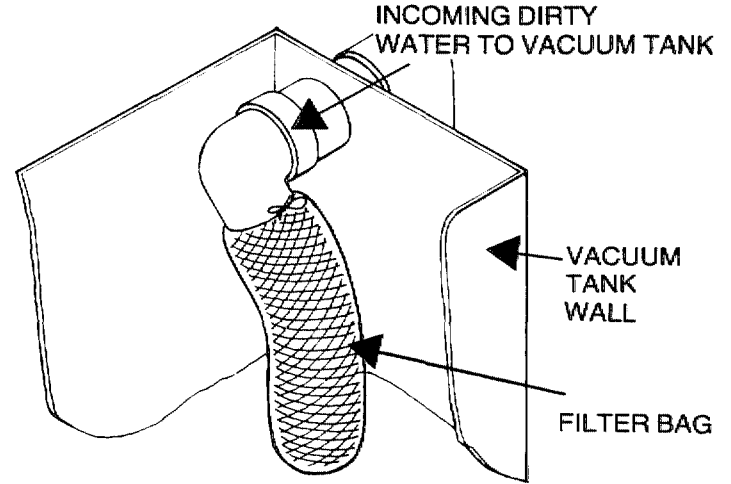

VACUUM FLOW DIAGRAM

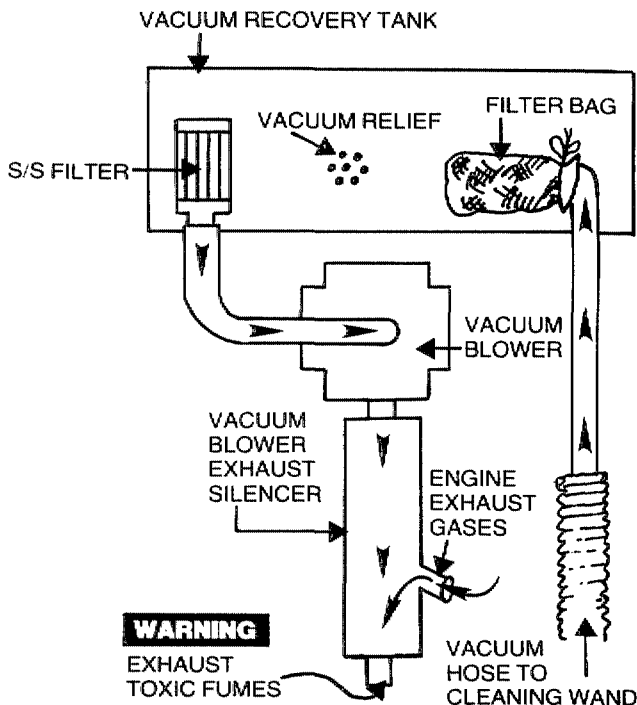

WARNING

EXHAUST TOXIC FUMES

BLOWER LUBRICANT

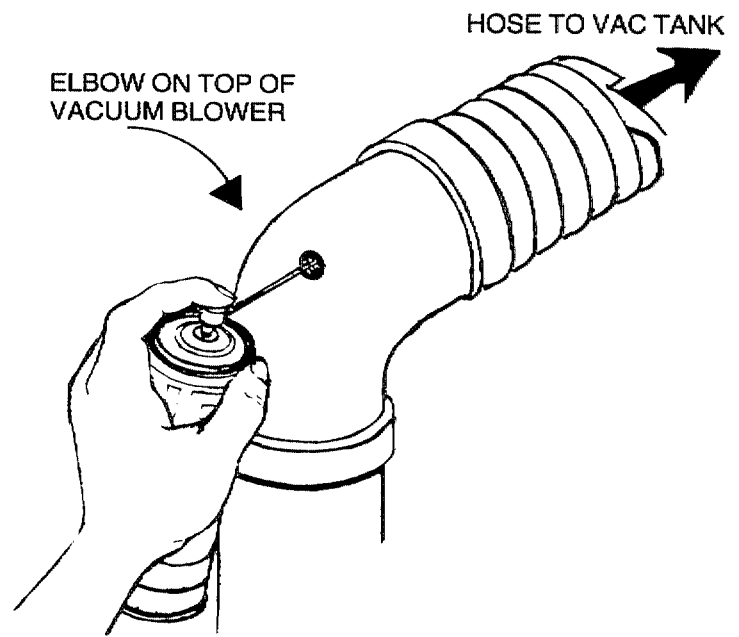

SPRAY LUBRICANT INTO VACUUM RELIEF HOLE FOR 3 TO 5 SECONDS, THEN IMMEDIATELY SHUT OFF MACHINE. USE ONLY LPS 1 OR WD-40 MOISTURE DISPLACING LUBRICANTS.

WARRANTY

FULLER warrants products of its manufacture to be free from defects in material and workmanship if properly installed, maintained, and operated under normal conditions with competent supervision.

No person, agent, representative or dealer is authorized to give any warranties on behalf of FULLER nor to assume for FULLER any other liability in connection with any of FULLER'S products.

This warranty shall extend for one (1) year from date of installation provided this equipment has been put into service within six months after shipment from the FULLER factory. If repairs or replacements are made by the Purchaser without FULLER'S prior written consent, FULLER'S warranty shall cease to be in effect. No allowance will be granted for any repairs or alterations made by the Purchaser without FULLER'S prior written consent.

Machinery, equipment and accessories furnished by FULLER, but manufactured by others, are warranted only to the extent of the original manufacturer's warranty to FULLER.

FULLER agrees at its option to repair at the point of shipment or to replace without charge f.o.b. point of shipment, any part or parts of products of FULLER'S manufacture, which within the specified warranty period shall be proved to FULLER'S satisfaction to have been defective when shipped, provided the Purchaser promptly notifies FULLER, in writing, of such alleged defect.

FULLER'S liability to Purchaser, whether in contract or in tort arising out of warranties, representations, instructions, or defects from any cause shall be limited to repairing or replacing of the defective part or parts as aforesaid, f.o.b. point of shipment.

No liability whatsoever shall attach to FULLER until said products have been paid for.

EXCEPT AS STATED IN THIS SECTION AND IN THE PRECEDING SECTION TITLED "WARRANTY" AND EXCEPT AS TO TITLE, THERE ARE NO GUARANTEES OR WARRANTIES OF MERCHANTABILITY, FITNESS, PERFORMANCE OR OTHERWISE, EXPRESS, IMPLIED OR STATUTORY, AND FULLER SHALL HAVE NO LIABILITY FOR CONSEQUENTIAL, INCIDENTAL OR OTHER DAMAGES, HOWSOEVER CAUSED.

DATE INSTALLED _____

MODEL _____

SERIAL # _____

FULLER COMPANY

2966 East Victoria Street
Compton, California 90224

FACTORY AUTHORIZED SERVICE CENTERS FOR SUTORBILT PRODUCTS

FULLER COMPANY / COMPTON DIVISION
2966 E. VICTORIA ST., COMPTON, CAL. 90224
213/636-9821 or 639-7600

FULLER COMPANY / MANHEIM DIVISION
236 SOUTH CHERRY STREET
MANHEIM, PENNSYLVANIA 17545
717/665-2224

BAYLISS MACHINE & WELDING CO.
2901 8TH AVENUE NORTH
BIRMINGHAM, ALABAMA 35203
205/323-6121

CAROTEK INCORPORATED
640 SAM NEWELL ROAD
MATHEWS, N. CAROLINA 28105
704/847-4406

BARNEY'S PUMPS INC.
3907 HIGHWAY 98 SOUTH
LAKELAND, FLORIDA 33802
813/686-8195

DYNMAC CORPORATION
7925 E. 40TH STREET
TULSA, OKLAHOMA 74145
918/627-0110

ASSOCIATED TECHNICAL SERVICES, INC.
1229 WAIMANU STREET # 21
HONOLULU, HAWAII 96814
808/537-1206

OLIVER & LAUGHTER EQUIPMENT CO.
10450 WESTOFFICE
HOUSTON, TEXAS 77042
713/977-2577

WM. W. MEYER & SONS
8261 ELMWOOD AVENUE
SKOKIE, ILLINOIS 60076
312/673-0312

ELECTRIC CRAFTS LTD.
3936 EDMONTON TRAIL N.E.
CALGARY, ALBERTA T2E 3P6
403/276-9676

GREGORY-SALISBURY & CO.
805 SOUTH FRONT STREET
NEW ORLEANS, LOUISIANA 70130
504/524-5207

PUMPS & POWER LTD.
1380 NAPIER STREET
VANCOUVER, B.C., CANADA
604/255-4341

SCHWARZ FOUNDRY COMPANY
2001 WEST FORT STREET
DETROIT, MICHIGAN 48216
313/496-1880

GATX-FULLER LTD.
721 PROGRESS AVENUE
SCARBOROUGH, ONTARIO, CANADA
416/438-6540



FULLER COMPANY

A GATX COMPANY
2966 EAST VICTORIA STREET
POST OFFICE, BOX 4308, COMPTON, CALIFORNIA 90224
TEL: (213) 639-7600 (213) 636-9821 TELEX: 67-4607

LUBRICATION

At the gear end the timing gear teeth are lubricated by being partially submerged. The gear teeth serve as oil slingers for gear end bearings. At the drive end the bearings are grease lubricated.

FILLING PROCEDURE

Remove square head vented oil fill plug (A) on gear end. Remove oil level plug (B) located in the head plate. Fill gear case until oil drips out of the oil level hole (B).

Use lubricants as listed.

Add fresh oil as required to maintain proper level. The oil should be drained, flushed and replaced every 1500 hours or more frequently if inspection so indicates. The oil drain plug is at (C).

NOTE: Older units may have the oil fill level and drain holes located in the cast iron gear case instead of in the head plate.

Bearings on drive end of blower require grease lubrication every 100 hours of operation. Bearings which require grease lubrication will have a grease fitting (D) at each bearing. When regreasing, the old grease will be forced out of the vents during operation. To prevent damage to seals, these vents must be kept open at all times.

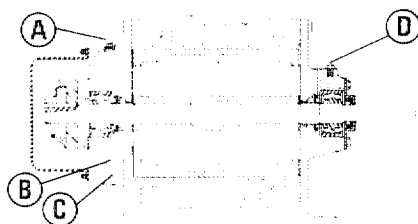

LUBRICATION INSTRUCTIONS FOR OIL LUBRICATED GEARS AND BEARINGS		
Add fresh oil as required to maintain proper level. Drain and refill every 1500 hours of operation under normal service, more frequently when required. Use a good quality oil.		
BLOWER DISCHARGE TEMPERATURE	OIL GRADE U.S.A.*	OIL VISCOSITY, CENTISTOKES @ 40° C
-40° to 32° F (-40° to 0° C)	SAE 10W	45
32° to 100° F (0° to 38° C)	SAE 20	100
100° to 275° F (38° to 135° C)	SAE 40	200
over 275° F (135° C)	SAE 50	250
*In applications with extreme variations in ambient temperature a 20W - 50W multiple viscosity oil is recommended.		
FOR GREASE LUBRICATED BEARINGS		
Service every 500 hours of operation		
BLOWER DISCHARGE TEMPERATURE	TYPE GREASE	
-40° to 275° F (-40° to 120° C)	No. 2 Bearing Grease	

VACUUM BLOWER TROUBLESHOOTING

PROBLEM:

• LOSS OF VACUUM

CAUSE AND/OR SOLUTION:

1. Collapsed vacuum hose between blower and vacuum tank.
 - A. Remove and replace hose. **NOTE:** A special reinforced hose is required for replacement.

2. Clogged stainless steel filter.
 - A. Remove and clean or replace stainless steel filter.
3. Defective vacuum tank seal.
 - A. Remove and replace vacuum tank seal.
4. Defective or 'open' vacuum tank dump valve.
 - A. Close valve.
 - B. Replace valve.
5. Fractured weld on vacuum tank.
 - A. Re-weld as required or replace tank.
6. Collapsed or kinked vacuum hose.
 - A. Reshape hose if possible and/or eliminate kinks.
7. Plugged vacuum hose.
 - A. Remove obstruction by reversing the vacuum hose.
8. Restriction in cleaning tool.
 - A. Remove obstruction.
9. Worn end plates or lobes in vacuum blower.
 - A. Replace worn components. **NOTE:** Must be accomplished by a qualified technician.
10. Loose coupling system between engine and blower.
 - A. The set screws may come loose causing blower to stand still while engine may be turning properly. **NOTE:** Unless the blower is seized or making a knocking noise, your vacuum loss is not caused by a bad blower.

PROBLEM:

• BLOWER IS SEIZED

CAUSE AND/OR SOLUTION:

1. Rust.
 - A. Spray rust dissolving lubricant onto lobes to emulsify rust and attempt to rotate vacuum lobes.
2. Foreign matter.
 - A. Disassemble and remove foreign matter and repair as required. **NOTE:** Disassembly must be accomplished by qualified technician.
3. Seized.
 - A. If you suspect that your blower has seized, remove coupling element, then run engine for a few seconds. This way you won't confuse similar problems.

NOTE: The above mentioned, rust, foreign matter and seizing are often caused from foam traveling through the blower.

PROBLEM:

• NOISE IN VACUUM BLOWER

CAUSE AND/OR SOLUTION:

1. Loose Direct Drive Coupler.
 - A. Examine coupler for defects and retighten lock bolts.
 - B. Replace coupler boot if it is either torn or punctured.
2. Worn Gears.
 - A. Remove and replace gears. **NOTE:** Replacement of gears must be accomplished by a qualified technician.
 - B. Timing of vacuum blower has been changed due to worn components. Replacement of components must be accomplished by a qualified technician.
3. Lack of Lubrication. **NOTE:** Permanent damage may have resulted from lack of lubrication.
 - A. Lubricate as specified by applicable vacuum blower manual. See index.
4. Worn bearings.
 - A. Remove and replace bearings as required. Must be accomplished by qualified technician.
5. Debris and/or foreign material build-up. **NOTE:** A stainless steel filter is provided in vacuum inlet located in vacuum tank to protect vacuum blower components.
 - A. Disassemble vacuum blower and remove foreign material. **NOTE:** Disassembly should be accomplished by qualified technician only. Replacement of worn parts is recommended if this procedure is necessary.
6. Loose or missing mounting bolts.
 - A. Tighten or reinstall mounting bolts.

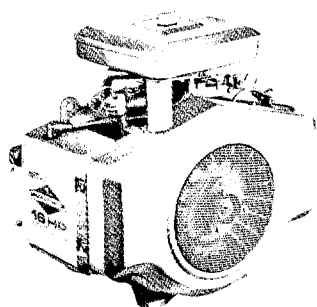

Briggs & Stratton OPERATING AND MAINTENANCE INSTRUCTIONS MODELS 401400 to 401499 421400 to 421499

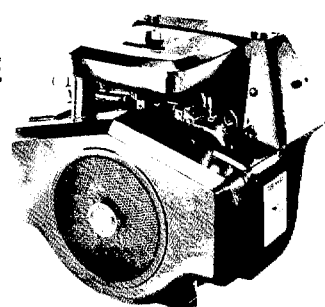

IN THE INTEREST OF SAFETY

DO NOT RUN ENGINE AT EXCESSIVE SPEEDS. Operating an engine at excessive speeds increases the hazard of personal injury. **DO NOT TAMPER WITH PARTS WHICH MAY INCREASE THE GOVERNED SPEED.**

For rotary lawnmower safety, A.N.S.I. Standard Safety Specifications for Power Lawn Mowers specify a maximum blade tip speed of 19,000 feet per minute (96.5 meters per second), primarily to reduce the hazard from thrown objects.

Rotary lawnmower manufacturers select the governed top speed of the engine based on the length and design of the cutter blade and design of other mower parts.

All rotary lawnmowers should be checked for conformance to the A.N.S.I. Standard Safety Specifications for Power Lawn Mowers on blade tip speed, if the engine is repaired or replaced, or if mower parts are changed.

DANGER: GASOLINE VAPOR IS HIGHLY FLAMMABLE. Refuel outdoors preferably, or only in well ventilated areas.

DO NOT STORE, SPILL OR USE GASOLINE NEAR AN OPEN FLAME or devices such as a stove, furnace, water heater which utilize a pilot light, or devices that can create a spark.

If gasoline is accidentally spilled, move machine away from area of spill and avoid creating any source of ignition until gasoline vapors have dissipated.

DO NOT REFUEL GASOLINE TANK WHILE ENGINE IS RUNNING.

DO NOT RUN THE ENGINE IN AN ENCLOSED AREA. Exhaust gases contain carbon monoxide, an odorless and deadly poison.

TO PREVENT ACCIDENTAL STARTING always remove the spark plugs from the engine, before working on the engine or equipment driven by the engine.

Except for adjustment; **DO NOT** operate engine if air cleaner or cover directly over carburetor air intake is removed. Removal of such part could create a fire hazard.

DO NOT OPERATE WITHOUT A MUFFLER OR TAMPER WITH THE EXHAUST SYSTEM. Damaged mufflers or spark arresters could create a fire hazard. Inspect periodically and replace if necessary.

DO NOT STRIKE FLYWHEEL with a hard object or metal tool as this may cause flywheel to shatter in operation, causing personal injury or property damage. Use Briggs & Stratton approved tools only, and if in doubt, contact your Authorized Briggs & Stratton Service Center.

ALWAYS KEEP HANDS AND FEET CLEAR OF ROTATING PARTS.

IN THE INTEREST OF ENVIRONMENT

A muffler which leaks because of rust or damage can permit an increased exhaust noise level. Therefore, examine the muffler periodically to be sure it is functioning effectively. To purchase a new muffler, see **SERVICE AND REPAIR INFORMATION.**

WARNING: If this engine is not equipped with a spark arrester and is to be used on any forest covered, brush covered, or grass covered unimproved land, before using on such land a spark arrester must be added to the muffler. The arrester must be maintained in effective working order by the operator. In the State of California the above is required by law (Section 4442 of the California Public Resources Code). Other states may have similar laws. Federal laws apply on federal lands. See your Authorized Briggs & Stratton Service Center for spark arrester muffler options.

SERVICE & REPAIR INFORMATION

If service or repair is needed, contact an Authorized Briggs & Stratton Service Center. To serve you promptly and efficiently, the Service Center will need the model, type and code number on your engine.

Each Authorized Service Center carries a stock of original Briggs & Stratton repair parts and is equipped with special service tools. Trained mechanics assure expert repair service on all Briggs & Stratton engines.

Major engine repairs should not be attempted unless you have the proper tools and a thorough knowledge of internal combustion engine repair procedure.

Your nearest service center is listed in the "Yellow Pages" under "Engines, Gasoline" or "Gasoline Engines." He is one of over 25,000 authorized dealers available to serve you.



This illustrated book includes common specifications, and detailed information covering the adjustment, tune-up and repair procedures for Twin Cylinder models. It is available from any Authorized Briggs & Stratton Service Center. Order as Part Number 271172.



BRIGGS & STRATTON CORP.
Milwaukee, Wisconsin 53201

BEFORE STARTING

READ THE OPERATING INSTRUCTIONS OF THE EQUIPMENT THIS ENGINE POWERS

Use a high quality detergent oil classified "For Service SC, SD, SE or MS." Detergent oils keep the engine cleaner and retard the formation of gum and varnish deposits. Nothing should be added to the recommended oil.

RECOMMENDED SAE VISCOSITY GRADES

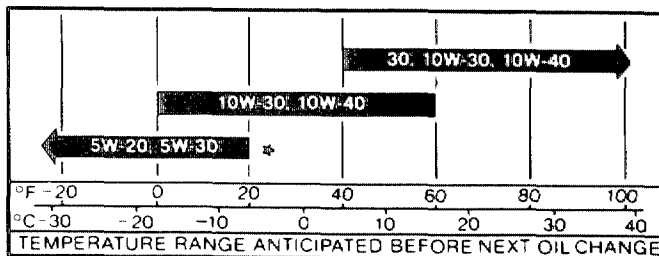

*If not available, a synthetic oil may be used having 5W-20, 5W-30 or 5W-40 viscosity.

FILL CRANKCASE WITH OIL

Place engine level. Clean area around oil fill before removing dipstick.

EXTENDED OIL FILL. Remove cap and dipstick. **FILL TO FULL MARK** on dipstick, **POUR SLOWLY.** Capacity 3 pints (1.42 liters). When checking oil level, push dipstick assembly firmly but slowly until cap bottom on tube. **DO NOT OVERFILL.** Dipstick assembly must be securely assembled into tube at all times when engine is operating.

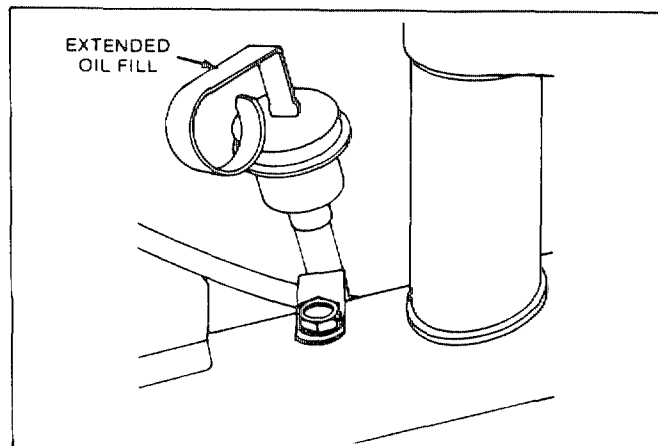

CHARGE BATTERY

Charge battery before use on engines equipped with (OPTIONAL) 12 volt electric starter motor. See equipment manufacturers' recommendations.

FILL FUEL TANK

Use clean, fresh, "regular grade leaded or low-lead" gasoline. **DO NOT MIX OIL WITH GASOLINE.**

NOTE: The use of "lead-free" gasoline produces fewer combustion deposits, but may shorten valve life if carburetor adjustment is too lean.

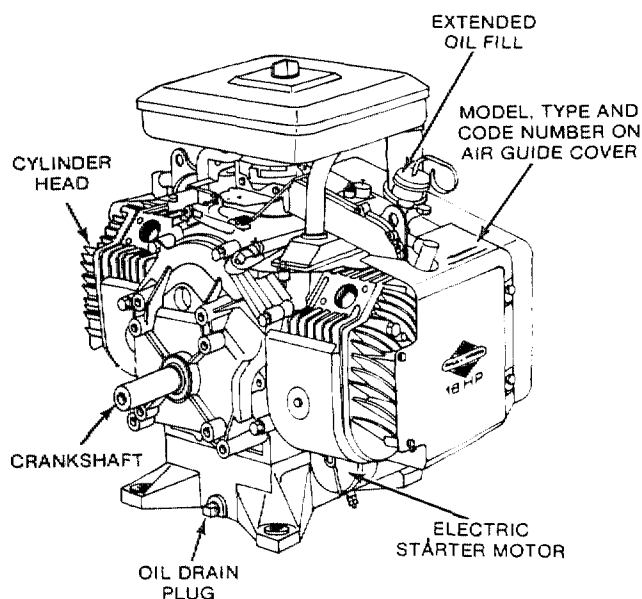
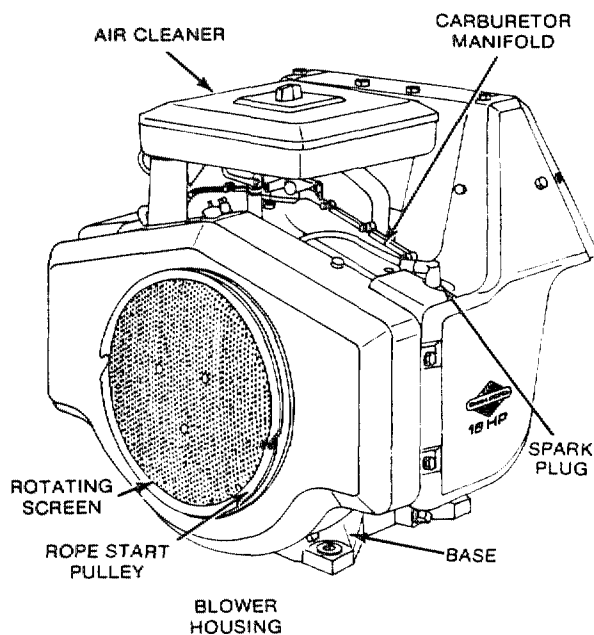

STARTING

OPEN FUEL VALVE on engines so equipped.

CHOKE ENGINE: Move equipment control lever to "CHOKE" position.

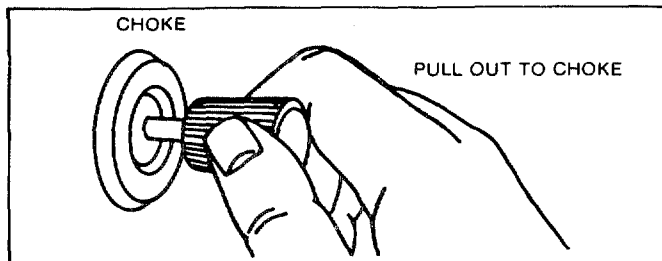

NOTE: This should fully close choke on carburetor. If it does not, remote control must be re-adjusted. See **ADJUSTMENT** section.

NOTE: A warm engine requires less choking than a cold engine.

GOVERNOR SPEED CONTROL LEVER: Move governor speed control lever to "RUN," "FAST" or "START" position if so equipped.

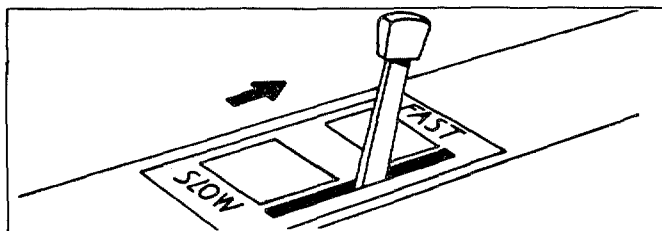

TO START ENGINE

DANGER: ALWAYS KEEP HANDS AND FEET CLEAR OF MOWER BLADE OR OTHER ROTATING MACHINERY.

Rope Starter. Wind the starter rope around the pulley in direction shown by arrow. Pull the rope with a quick full arm stroke to overcome compression and prevent kickback. Repeat if necessary with choke opened slightly. When engine starts open choke gradually.

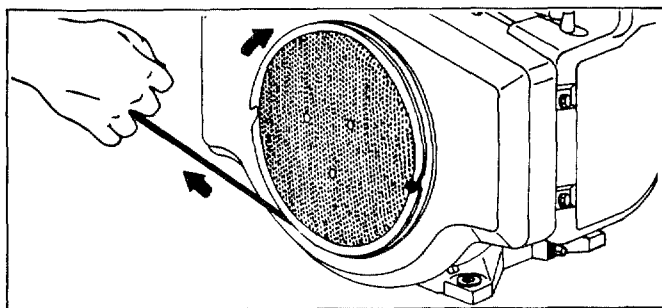

CAUTION: When using rope starter to crank engine, use caution so knotted end of rope does not strike persons standing nearby.

Electric Starter. Turn key to "Start" position and/or press starter button on powered equipment. When engine starts open choke gradually.

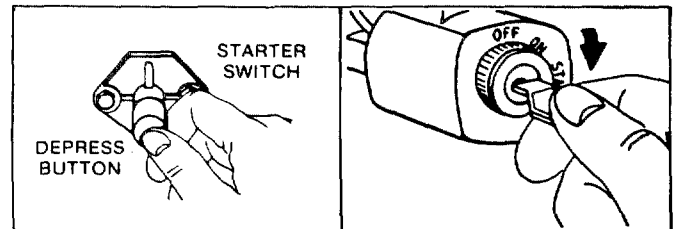

When equipment is not in operation, provide protection from direct exposure to weather.

COLD WEATHER STARTING HINTS

1. Be sure to use the proper oil for the temperature expected.
2. Declutch all possible external loads.
3. Set throttle at part-throttle position.
4. A slightly richer fuel mixture, obtained by turning carburetor needle valve 1/8 turn counterclockwise, will usually improve cold starting.
5. A warm battery has much more starting capacity than a cold battery.
6. Use fresh winter grade fuel.

NOTE: Winter grade gasoline has higher volatility to improve starting. Do not use gasoline left over from summer.

TO STOP ENGINE

Turn key to "OFF" position.

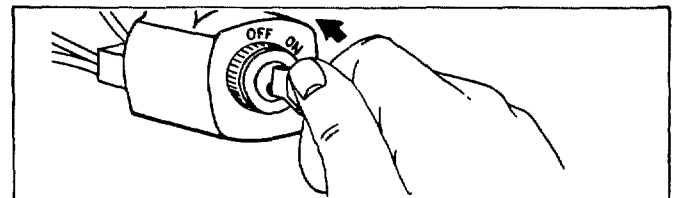

CAUTION: Always remove key from switch when leaving equipment unattended or when equipment is not in use.

MAINTENANCE

CHECK OIL LEVEL regularly — after each five hours of operation. BE SURE OIL LEVEL IS MAINTAINED.

CHANGE OIL after first five hours of operation. Thereafter change oil every 25 hours of operation. Remove oil drain plug and drain oil while engine is warm. Replace drain plug. Remove dipstick and refill with new oil of proper grade. Replace dipstick.

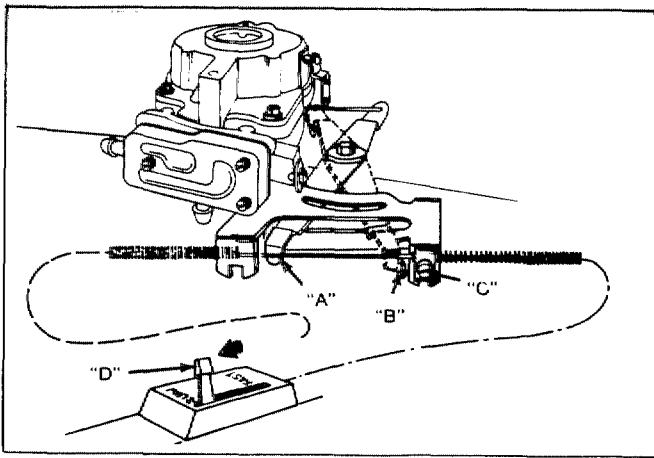

GENERAL INFORMATION

These engines are two-cylinder L-head, air-cooled type.

MODEL SERIES 401400 to 401499

- Bore 3-7/16" (87.31 mm)
- Stroke 2-5/32" (54.77 mm)
- Displacement 40.00 cu. in. (656.0 cc)
- Horsepower 16 HP Max. @ 3600 RPM
- Torque (Ft.-Lbs.) 25.8 Max. @ 2700 RPM

MODEL SERIES 421400 to 421499

- Bore 3-7/16" (87.31 mm)
- Stroke 2-9/32" (57.94 mm)
- Displacement 42.33 cu. in. (694.0 cc)
- Horsepower 18 HP @ 3600 RPM
- Torque (Ft.-Lbs.) 28.6 @ 2600 RPM

The horsepower ratings listed above are established in accordance with the Society of Automotive Engineers Test Code - J607. For practical operation, the horsepower loading should not exceed 85% of this rating. Engine power will decrease 3½% for each 1,000 feet (304.8 m) above sea level and 1% for each 10° above 60° F (16° C).

In some areas, local law requires the use of a resistor spark plug so as to suppress ignition signals. If an engine was originally equipped with resistor spark plugs, be sure to use the same type of spark plugs for replacement.

TUNE-UP SPECIFICATIONS

Spark Plug Type	Champion	Autolite
Long Plug	J-8	295
Resistor Long Plug	RJ-8	306
Spark Plug Gap	.030" (.76 mm)	
Ignition Point Gap	.020" (.51 mm)	
Intake Valve Clearance **	.004" - .006" (.10 - .15 mm)	
Exhaust Valve Clearance **	.007" - .009" (.18 - .23 mm)	

**with valve spring installed.

WARNING: For electrical safety always remove cable from negative (-) side of the battery before attempting any repairs or maintenance.

BRIGGS & STRATTON ENGINES ARE MADE UNDER ONE OR MORE OF THE FOLLOWING PATENTS

28,960	3,149,618	3,276,439	3,526,146	3,625,071	3,831,268	3,968,854
2,999,491	3,194,224	3,305,223	3,572,218	3,650,354	3,882,336	3,971,353
2,999,562	3,236,937	3,457,804	3,572,307	3,745,393	3,901,199	3,991,152
3,114,851	3,242,741	3,465,740	3,625,492	3,738,345	3,961,724	4,168,288
3,118,433	3,252,449					

TYPICAL WIRING DIAGRAMS

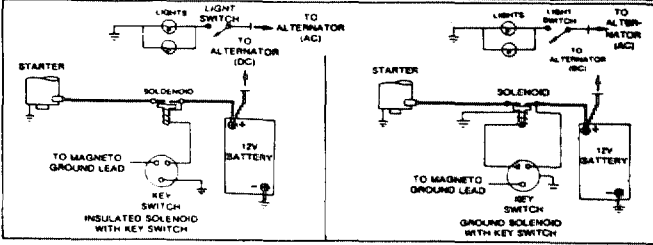
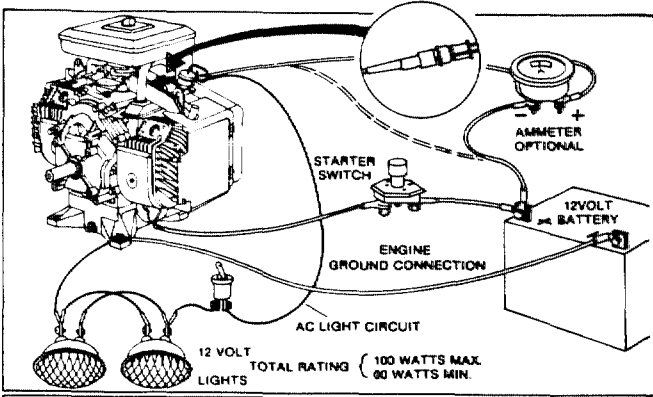

Dual Circuit

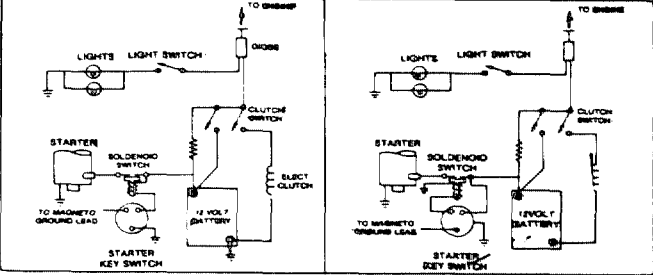

Tri-Circuit

STORAGE INSTRUCTIONS

Engines to be stored over 30 days should be completely drained of fuel to prevent gum deposits forming on essential carburetor parts, fuel filter and tank.

NOTE: The use of a fuel additive, such as STA-BIL, or an equivalent, will minimize the formation of fuel gum deposits during storage. Such an additive may be added to the gasoline in the fuel tank of the engine, or to the gasoline in a storage container.

- a. All fuel should be removed from the tank. Run the engine until it stops from lack of fuel. The small amount of fuel that remains in the sump of the tank should be removed by absorbing it with a clean, dry cloth.
- b. While engine is still warm, drain oil from crankcase. Refill with fresh oil.
- c. Remove spark plugs, pour one ounce (29.6 cc) of engine oil into each cylinder and crank slowly to distribute oil. Replace spark plugs.
- d. Clean dirt and chaff from cylinders, cylinder head fins, blower housing, rotating screen and muffler areas.
- e. Store in a clean and dry area.

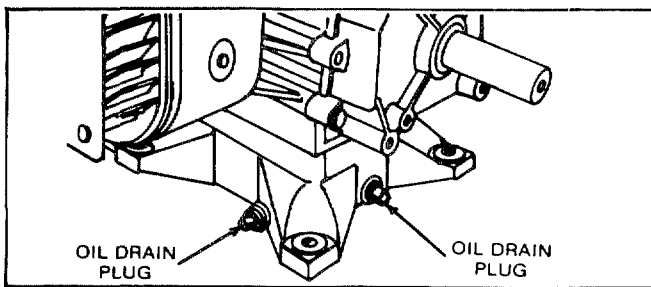

TO SERVICE DUAL ELEMENT AIR CLEANER

Clean and re-oil foam pre-cleaner at three month intervals or every 25 hours, whichever occurs first.

NOTE: Service air cleaner more often under dusty conditions.

1. Remove knob and cover.
2. Remove foam pre-cleaner by sliding it off the paper cartridge.
3. a. Wash foam pre-cleaner in kerosene or liquid detergent and water.
b. Wrap foam pre-cleaner in cloth and squeeze dry.
c. Saturate foam pre-cleaner in engine oil. Squeeze to remove excess oil.
4. Install foam pre-cleaner over paper cartridge. Re-assemble cover and screw down tight.

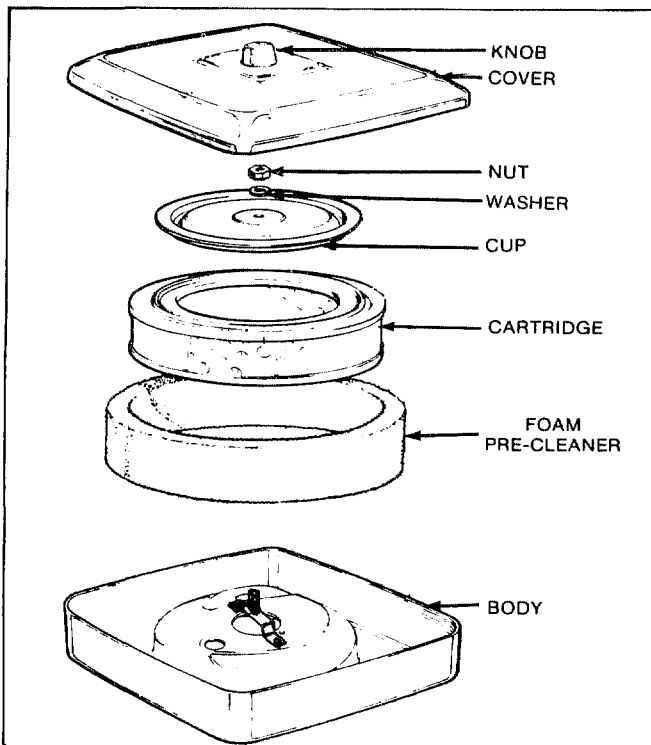

Yearly or every 100 hours, whichever occurs first, remove paper cartridge. Clean by tapping gently on flat surface. If very dirty, replace cartridge, or wash in a low or non-sudsing detergent and warm water solution. Rinse thoroughly with flowing water from inside out, until water is clear. Cartridge must be allowed to stand and air dry thoroughly before using. Service more often if necessary.

CAUTION: Petroleum solvents, such as kerosene, are not to be used to clean cartridge. They may cause deterioration of the cartridge. **DO NOT OIL CARTRIDGE. DO NOT USE PRESSURIZED AIR TO CLEAN OR DRY CARTRIDGE.**

CLEAN COOLING SYSTEM — Grass, chaff or dirt may clog the rotating screen and the air cooling system, especially after prolonged service in cutting tall dry grasses. Yearly or every 100 hours, whichever occurs first, remove the blower housing and clean the areas shown to avoid overspeeding, overheating and engine damage. Clean more often if necessary.

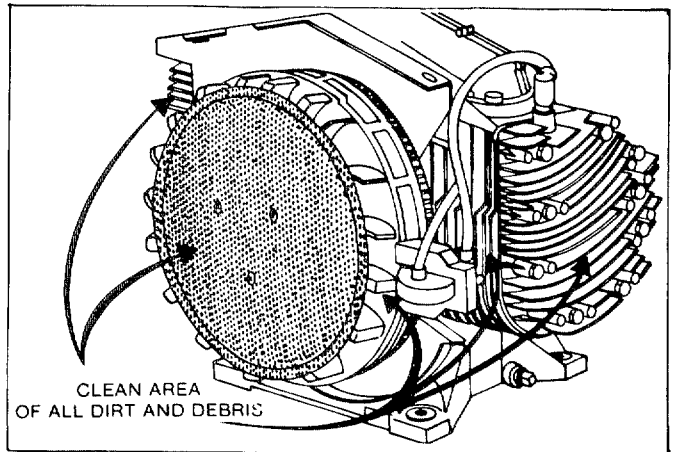

DANGER: Periodically clean muffler area to remove all grass, dirt and combustible debris.

SPARK PLUGS — Clean and reset gap at .030" every 100 hours of operation.

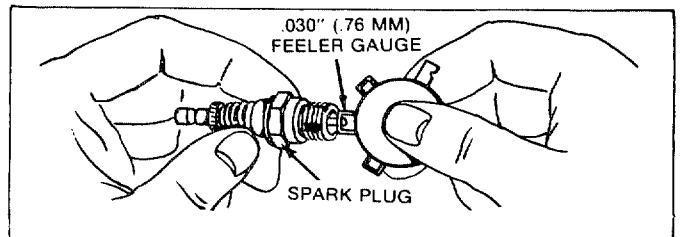

CAUTION: Do not blast clean spark plugs. Spark plug should be cleaned by scraping or wire brushing and washing with a commercial solvent.

Sparking can occur if wire terminals do not fit firmly on spark plugs. Reform terminals if necessary.

REMOVE COMBUSTION DEPOSITS every 100-300 hours of operation. Remove cylinder heads and cylinder head shields. Scrape and wire brush the combustion deposits from cylinder, cylinder heads, top of pistons and around valves. Use a soft brush to remove deposits. Re-assemble gaskets, cylinder heads and cylinder head shields. Turn screws down finger tight, with the three longer screws around the exhaust valve, if so equipped. Torque cylinder head screws in a staggered sequence to 165 inch pounds (18.65 Nm).

SPARK ARRESTER EQUIPPED MUFFLER — If engine muffler is equipped with spark arrester screen assembly, remove every 50 hours for cleaning and inspection. Replace if damaged.

ADJUSTMENTS

CARBURETOR ADJUSTMENTS

Minor carburetor adjustment may be required to compensate for differences in fuel, temperature, altitude or load.

INITIAL ADJUSTMENT — Turn idle and needle valves clockwise until they just close.

CAUTION: Valves may be damaged by turning them in too far.

Now open needle and idle valves 1½ turns counterclockwise. This initial adjustment will permit the engine to be started and warmed up prior to final adjustment.

NOTE: All carburetor adjustments must be made with the air cleaner on engine.

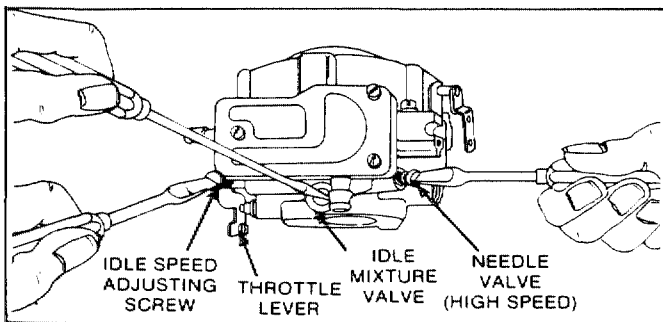

FINAL ADJUSTMENT PROCEDURE

Idle Valve Mixture

Place governor speed control lever in governed "IDLE" position. Hold throttle lever against idle stop and set idle speed adjusting screw to obtain 1400 RPM. Turn idle valve slowly clockwise (lean mixture) until engine misses or RPM slows. Then turn idle valve ½ turn counterclockwise.

Governed Idle

Hold throttle lever against idle speed adjusting screw. Adjust idle speed screw to obtain 900 RPM. Release the throttle. With governor speed control lever in governed "IDLE" position, align ⅛" diameter holes in control plate and lever as shown. Re-adjust governor speed control casing and wire if required. See Governor Speed Control Adjustment section. Adjust tang "A" to obtain 1400 RPM governed idle.

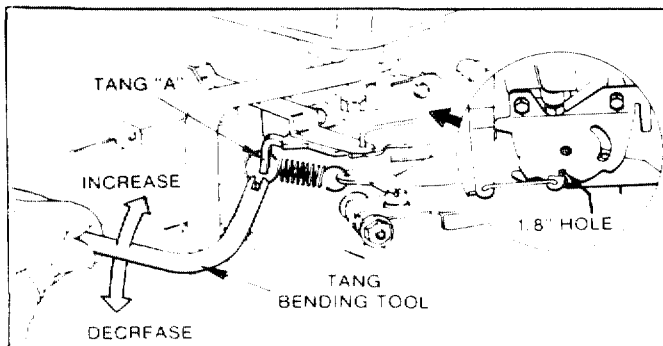

NOTE: Governed idle must be adjusted on all engines for proper operation. The smaller spring keeps the engine on governor, even at idle speed. If moderate loads are applied at idle, the engine will not stall. Governed idle speed should be no lower than 1100 RPM.

Needle Valve (High Speed)

Place governor speed control lever in fast position. Then turn needle valve in slowly clockwise (lean) until engine misses or RPM slows. Then turn needle valve ½ turn counterclockwise.

If engine does not accelerate properly, readjust needle valve approximately ¼ turn counterclockwise (richer).

CONTROL ADJUSTMENTS

Proper choke and speed control operation is dependent upon proper adjustment of remote controls on the powered equipment.

TO CHECK OPERATION OF CHOKE CONTROLS:

Move remote control lever to "choke" position. The carburetor choke should be closed.

TO ADJUST CHOKE:

Place remote control lever on equipment in "CHOKE" position. Loosen control casing clamp screw. Move control casing and wire until choke is completely closed. Tighten casing clamp screw.

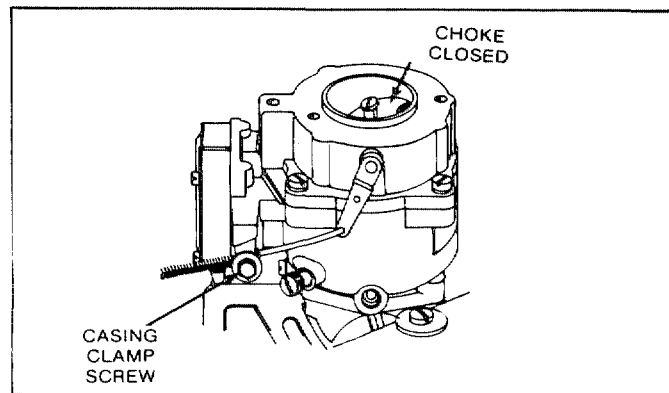

GOVERNOR SPEED CONTROL ADJUSTMENT

The acceptable operating speed range is 1800 to 3600 RPM. Idle speed is 1400 RPM. The manufacturer of the equipment on which the engine is used, specifies the top governed no load speed at which the engine may be operated. DO NOT EXCEED this speed.

Engine speed is controlled by movement of the control lever. Move control lever on equipment, "D", to slowest engine speed possible. Throttle lever on carburetor should touch idle speed adjusting screw. To adjust, loosen control casing clamp screw "C." Move control casing and wire in direction shown by arrow until throttle lever touches idle speed adjusting screw on carburetor. Retighten casing clamp screw "C." Move control lever "D" to "FAST" position. If engine exceeds equipment manufacturer's maximum governed no load RPM, move lever "D" to obtain recommended speed. Bend tang "B" to touch lever "A."

CAUTION: Throttle lever on carburetor MUST touch idle speed adjusting screw when equipment control lever is in slowest position.

Superseding Warranty

BRIGGS & STRATTON ENGINE WARRANTY POLICY

effective October 1, 1976

Replaces all undated previous Warranties and all Warranties dated before October 1, 1976

When warranty repair is justified, Briggs & Stratton Corporation welcomes such repair by any of its Authorized Service Centers.

In most instances, the requests for warranty brought to the attention of our service accounts are handled in a prompt routine manner with no question regarding their validity. However, some requests for warranty are received which are not justified. In these cases, engine owners may not be aware that the premature failure of their engine was the result of abuse or neglect, or that the difficulty which they experience is caused by the equipment rather than the engine.

BRIGGS & STRATTON WARRANTY covers only DEFECTIVE MATERIAL and/or WORKMANSHIP.

ONE YEAR LIMITED WARRANTY

"For one year from date of purchase, Briggs & Stratton Corporation will replace for the original purchasers, free of charge, any part, or parts of the engine, found upon examination by any Factory Authorized Service Center, or by the Factory at Milwaukee, Wisconsin, to be defective in material or workmanship or both; this is the exclusive remedy. All transportation charges on parts submitted for replacement under this warranty must be borne by purchaser. For warranty service contact your nearest Authorized Service Center as listed in the 'Yellow Pages' under 'Engines, Gasoline' or 'Gasoline Engines.' THERE IS NO OTHER EXPRESS WARRANTY. IMPLIED WARRANTIES, INCLUDING THOSE OF MERCHANTABILITY AND FITNESS FOR A PARTICULAR PURPOSE ARE LIMITED TO ONE YEAR FROM PURCHASE AND TO THE EXTENT PERMITTED BY LAW ANY AND ALL IMPLIED WARRANTIES ARE EXCLUDED. LIABILITY FOR CONSEQUENTIAL DAMAGES UNDER ANY AND ALL WARRANTIES ARE EXCLUDED TO THE EXTENT EXCLUSION IS PERMITTED BY LAW. Some states do not allow limitations on how long an implied warranty lasts, and some states do not allow the exclusion or limitation of incidental or consequential damages, so the above limitation and exclusion may not apply to you. This warranty gives you specific legal rights and you may also have other rights which vary from state to state."

Briggs & Stratton Corporation

F. P. Stratton, Jr.

F.P. Stratton, Jr.
President and Chief Executive Officer

NO REGISTRATION (WARRANTY) CARD IS NECESSARY TO OBTAIN WARRANTY ON BRIGGS & STRATTON ENGINES. FILL IN THE REQUIRED INFORMATION AND RETAIN FOR YOUR RECORD:

(See Decal on Blower Housing for Model, Type and Code Number)

Engine Model No. _____ Type No. _____ Code No. _____

Dealer Purchased From _____

Type of Equipment _____

Name or Trademark of Equipment Manufacturer _____

If warranty service is needed contact your nearest Authorized Service Center. For prompt attention your center will need to know the engine model, type and code number, the trouble experienced and the total number of hours the engine has run. If you differ with the decision of a Service Center on a warranty claim, ask the Service Center to submit all supporting facts to the Factory for review. If the Factory decides that your claim is justified, you will be fully reimbursed for those items accepted as defective.

(over)

To avoid misunderstandings which might occur between engine owners and authorized Briggs & Stratton service accounts, we are listing causes of engine failures, where repair or replacement is NOT covered by Briggs & Stratton warranty.

NORMAL WEAR:

Warranty will not cover repair where normal use has exhausted the life of a part or engine. Engines, like all mechanical devices, need periodic parts replacement and service to perform well. It should be remembered that the service life of any engine is dependent on the care it receives and the conditions under which it has to operate. Some applications, such as tillers, trash pumps, rotary mowers, are very often used in dusty or dirty conditions, which can cause what appears to be premature wear. Such wear, when caused by dirt, dust, spark plug cleaning grit or other abrasive material, which has entered the engine because of improper maintenance, is not covered by Warranty.

ABUSE OR NEGLIGENCE:

1. Bent or broken crankshafts: Such damage is normally the result of abuse, such as striking a solid object with the cutter blade on a rotary lawn mower, and is not covered by Warranty.
2. Engine repairs required from the use of old or stale fuel are not covered by Warranty. Such failures would include sticking valves, and carburetors and fuel pipes which are clogged by gum deposits which form through the use of stale fuel. Always use clean fresh regular gasoline.
3. Parts which are scored or broken because an engine was operated without sufficient lubricating oil or the proper grade of lubricating oil are not covered by Warranty. Check oil level at least every five hours and refill when necessary. Change oil at recommended intervals.
4. Damage caused by overheating or overspeeding is not covered by Warranty. Overspeeding or overheating occurs if the cooling fins become plugged with dirt, grass or debris, or if an engine is operated in a confined area without sufficient ventilation. Clean fins on the cylinder, cylinder head and flywheel regularly.
5. Damage or wear caused by dirt which enters the engine because of improper air cleaner maintenance is not covered by Warranty. Clean and re-oil the air cleaner regularly.
6. Damage or wear caused by grit from blast cleaning spark plugs is not covered by Warranty. We do not approve of cleaning spark plugs on an abrasive blast cleaning machine, since grit can remain in the plug, and later enter the engine.
7. Warranty does not cover the tune-up or adjustment of an engine unless the need for such repair is the result of defects in material or workmanship or both. If equipment is assembled and adjusted by the owner, the engine Operating and Maintenance Instructions are sufficiently clear to permit the average owner to make minor adjustments. Such minor adjustments are NOT covered by Warranty.
8. Broken parts, which result from excessive vibration caused by loose engine mounting, loose cutter blades, blade imbalance, improperly attaching equipment to engine crankshaft, overspeeding or abuse in operation, are not covered by Warranty.
9. Repair or adjustment of associated parts or assemblies such as clutches, transmissions, remote controls, etc., which are not of Briggs & Stratton manufacture will not be covered by Briggs & Stratton Warranty.
10. Only ORIGINAL Briggs & Stratton parts, or parts approved by Briggs & Stratton may be covered by Warranty.

WARRANTY IS AVAILABLE ONLY THROUGH SERVICE CENTERS WHICH HAVE BEEN AUTHORIZED BY THE BRIGGS & STRATTON CORPORATION. YOUR NEAREST SERVICE CENTER IS LISTED IN THE YELLOW PAGES OF YOUR TELEPHONE DIRECTORY, UNDER "ENGINES, GASOLINE" OR "GASOLINE ENGINES."

ENGINE

An engine instruction brochure is included with this manual (see index) which may assist you in resolving engine related problems.

PROBLEMS:

- ENGINE FAILS TO START
- ENGINE RUNS ROUGH
- ENGINE BACKFIRES
- ENGINE FAILS TO ACCELERATE
- ENGINE REDUCES SPEED TO LOW RPM UNDER LOAD

CAUSES AND/OR SOLUTION:

1. Loss of fuel
 - A. Empty gas tank.
 - B. Plugged fuel line or filter.
 - C. Defective fuel pump. (Replace with mfg. suggested replacement parts only).
 - D. Gas line kinked, crushed or quick disconnect inside the truck not connected.
2. Blown master fuse.
 - A. Electrical short.
 - B. Defective fuse.
3. Worn or maladjusted points (Onan eng. Only) (Briggs has electronic ignition).
 - A. Remove and replace points and condenser.
 - B. Clean and adjust points.
4. Defective spark plugs
 - A. Remove and replace.
 - B. Clean and regap.
5. Defective spark plug wires
 - A. Spark plug wires along with many others may, at certain points come in contact with heated parts (exhaust manifold) or abrasive parts (sharp metal, teflon hose). This may be taken into consideration for electrical shorts.
 - B. Remove and replace.
6. Low compression
 - A. Defective valve.
 - B. Stuck valve.
 - C. Worn compression rings.
 - D. Defective piston.
7. Float switch in recovery tank inoperative. **NOTE:** Temporary repair permits disconnection of float switch wire between tank and machine. Continued operation with this condition will compromise vac blower.
 - A. Switch stuck on upright position by foreign material.
 - B. Defective float switch.
8. Engine will not turn over
 - A. Dead battery
 - B. Loose terminal connection on battery or ignition switch.
 - C. Defective starter.
 - D. Seized engine or blower.
9. Defective Carburetor or gas leakage.
 - A. Clean carb.
 - B. Replace carb.
 - C. Choke locked in closed position.

CAUTION

- D. When replacing fuel pump insure that it is the same pressure rating recommended by mfg.
10. Improperly adjusted carb. **NOTE:** A comprehensive manual is available and defines necessary adjustments.
 - A. Incorrect air mixture ratio adjustment.
 - B. Incorrect float level adjustment.
11. Carbon build-up in cylinders. **NOTE:** Carbon build-up can be minimized by using unleaded regular gas. Should carbon removal be necessary, reinstall heads with new gaskets.

- A. Carbon build-up may be excessive if carb. or valves are improperly adjusted, engine RPM too low, improper spark plug gap.
- B. Remove cylinder heads and eliminate carbon build-up with wire brush.
12. Incorrect timing
 - A. Timing may become offset if point box is not secure or if points are out of adjustment. (Onan only).
13. Dirty air cleaner
 - A. If exhaust gaskets do not seat properly or heat exchanger gasket is bad, exhaust may heat and melt the the air cleaner requiring much clean-up repair.
14. Clogged fuel filter
 - A. Remove and replace
15. Low oil level or malfunctioning oil pump
 - A. Oil pressure sensors can be installed on the engine. This will eliminate many problems which may occur.
16. Vacuum tank full
 - A. Empty vacuum tank

ELECTRICAL SYSTEM

30

The entire electrical system operates on 12 volts DC which is provided by a battery. Battery levels are sustained by a 7 amp alternator designed within the engine.

NOTE: When new battery is installed insure it is properly charged before installation or damage to the charging regulator may occur.

PROBLEM:

• LOW BATTERY VOLTAGE

CAUSE AND/OR SOLUTION:

1. Defective battery
 - A. Remove and replace.
2. Corroded battery terminals
 - A. Clean terminals and battery posts.
3. Low battery fluid
 - A. Add water to appropriate level.
4. Loose wiring within electrical system.
 - A. Examine all terminal connections and verify that they are secure. **NOTE:** Give special attention to ignition switch terminals.

5. Blown charging fuse
 - A. Remove and replace fuse.
 - B. Check battery charge.
 - C. Check battery cells with hydrometer.
6. Electrical short in wiring system
 - A. Examine electrical systems for bare wires.
7. Poor ground connection
 - A. Examine terminal and remove corrosion if necessary.
 - B. Follow ground wire from (-) of battery to where it grounds at the frame. If it is grounded to painted steel then scratch some of the paint off to allow for circuit to be completed through the steel.

INOPERATIVE HOUR METER

CAUSE AND/OR SOLUTION:

1. Time is not advancing correctly
 - A. Verify 12 volts DC is available at the hour meter with the ignition switch turned on. This can be accomplished with a volt meter or a test lamp.
 - B. Remove and replace hour meter if 12 volts is available.
 - C. A nylon gear within the clock may have been jammed due to a sudden jolt of the machine or truck. You may try simply tapping on the meter to try to free the nylon gear.

BOB CAT 2/290 ELECTRICAL DIAGRAM

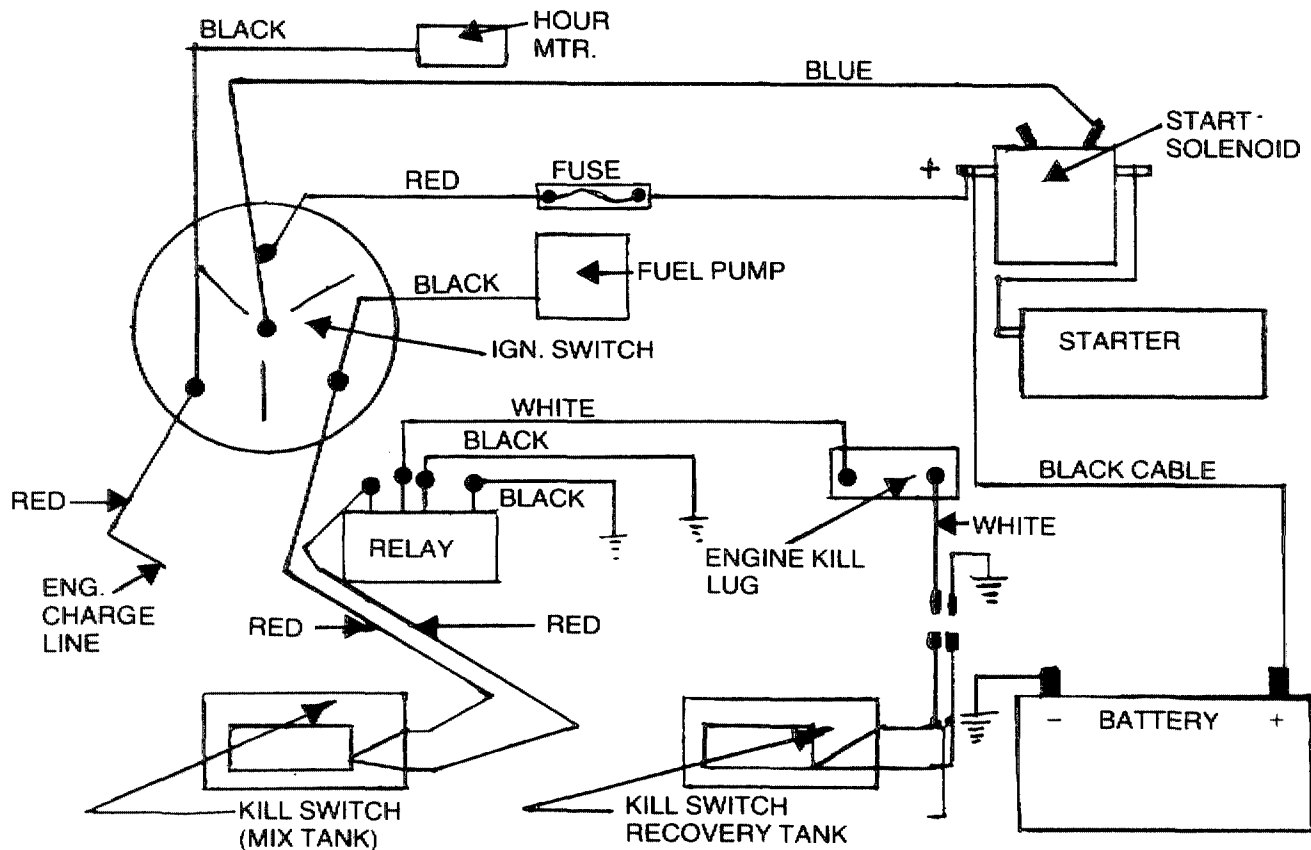

MACHINE INSTALLATION INFORMATION

There are two ways of positioning the machine in the truck as shown on the following page. There are also two locations for the vacuum recovery tank to be positioned. First, the standard way with the tank directly alongside the machine. Second, with the tank across the back of the machine as shown below; this location is most space efficient.

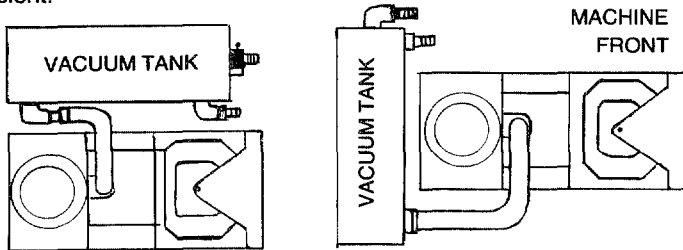

Whichever way you select, make sure the tank and machine are secured to the floor of the van to insure driver safety.

It is important that the machine be placed as close to the door as possible so that outside air can be pulled into the engine for proper cooling.

WARNING

It is recommended by the manufacturer that the exhaust from the front of the machine be vented down under the truck to prevent carbon monoxide from entering the job site. Always park the truck so the exhaust is blowing away from the job site.

The manufacturer also recommends that installation of aluminum vents in the truck roof to allow heat from the heater to escape.

WARNING

Never operate this machine with a portable propane tank or a portable gas can inside the truck. The heater is an open flame type and could cause a fire or explosion.

Mount a fire extinguisher just inside the rear or side door for emergencies.

MACHINE TIE DOWN CLEAT ILLUSTRATION

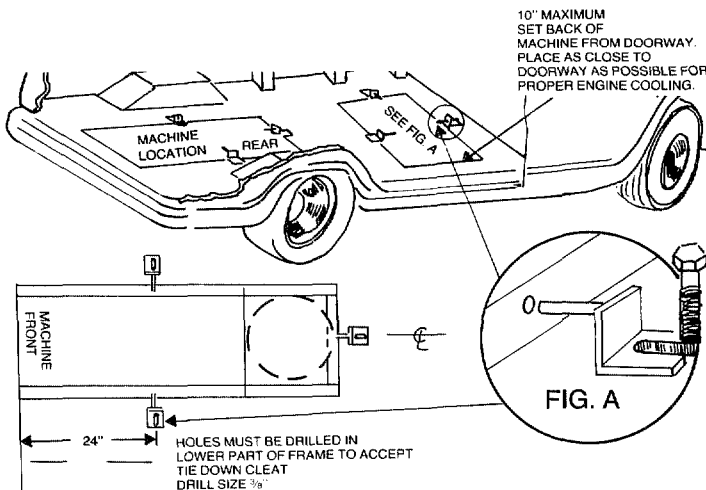

PROPANE TANK PLUMBING

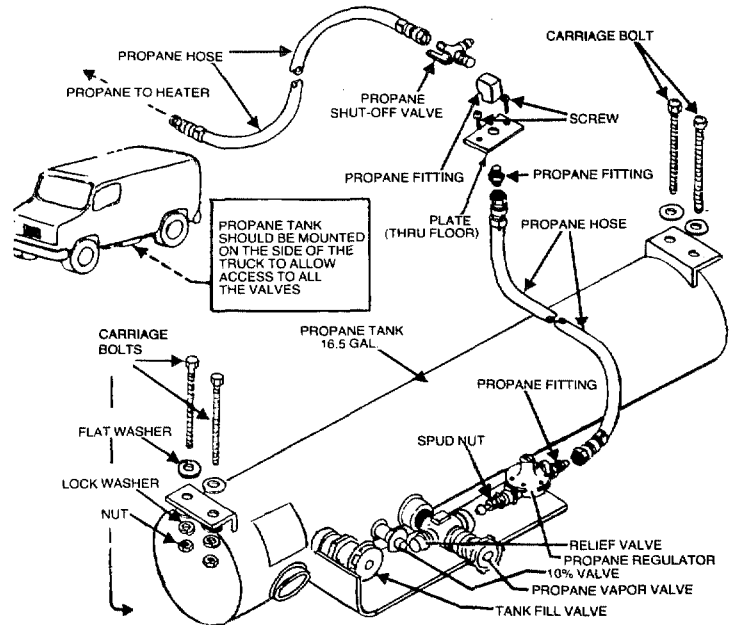

THRU-FLOOR GAS HOOK-UP AND INSTALLATION

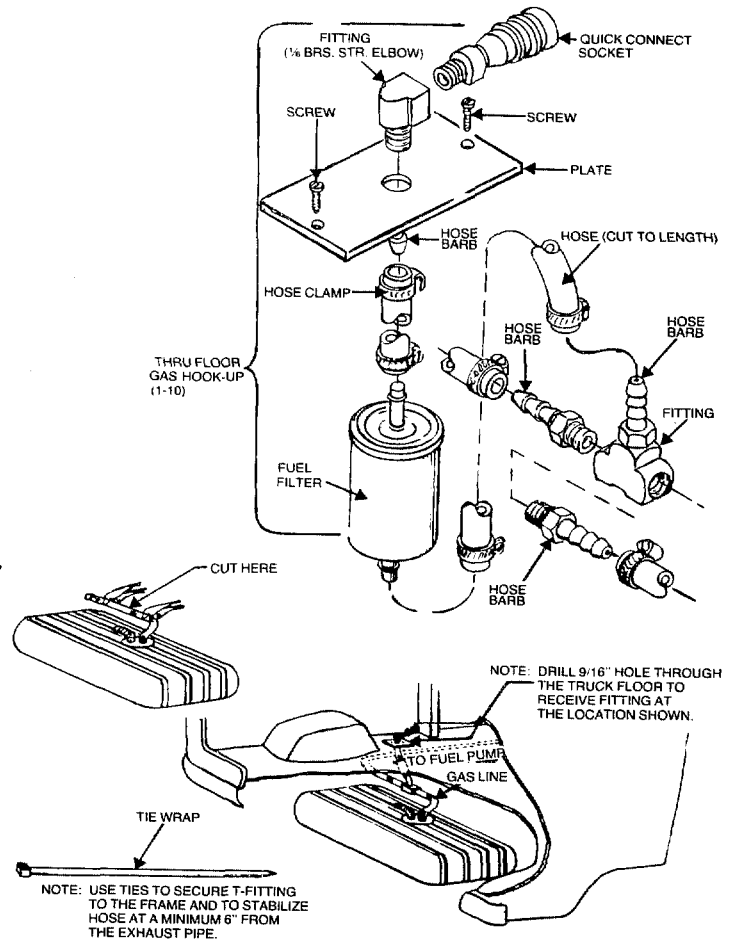

WATER SOFTENER

Many areas of the country have an excess of minerals in the water which results in what is commonly called "hard water". These minerals tend to adhere to the insides of heater coils and other parts of the machines causing damage and a loss of cleaning effectiveness.

Reports from several of our machine users commending the results of the use of water softeners in conjunction with their machines prompts us to recommend the procedure to everyone in a "hard water" area.

The relatively low cost of a water softener service is more than made up for in the increased life of machine parts and continued cleaning efficiency. The water softener will also increase the effectiveness of the cleaning chemical being used, therefore, less chemical will be needed.

Contact a water softener distributor in your area for information on the rental of a simple water treatment unit to carry in your truck. Be sure to change the water softener in accordance with the capability of the softener. Example: If the softener will treat 900 gallons of water and the machines uses an average of 30 gallons per hour of use, and an average of 5 hours a day, would be 150 gallons a day. 5 days would equal 750 gallons of water, therefore, the softener would be changed every 6 working days for maximum softening.

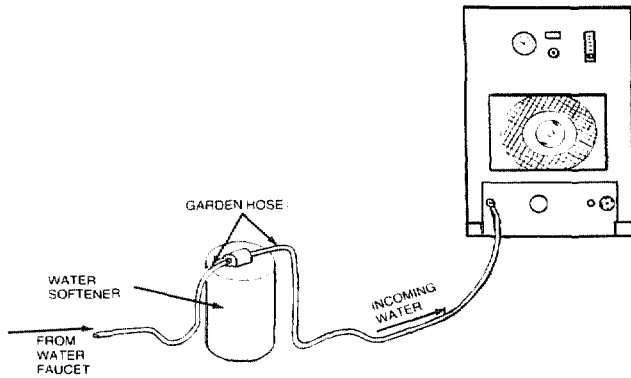

JET ASSEMBLY

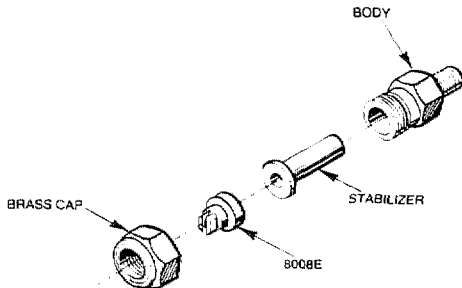

WAND ASSEMBLY

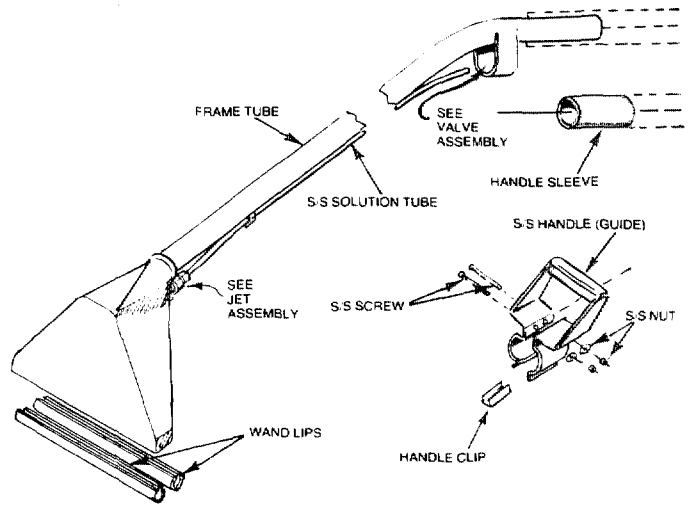

VALVE ASSEMBLY

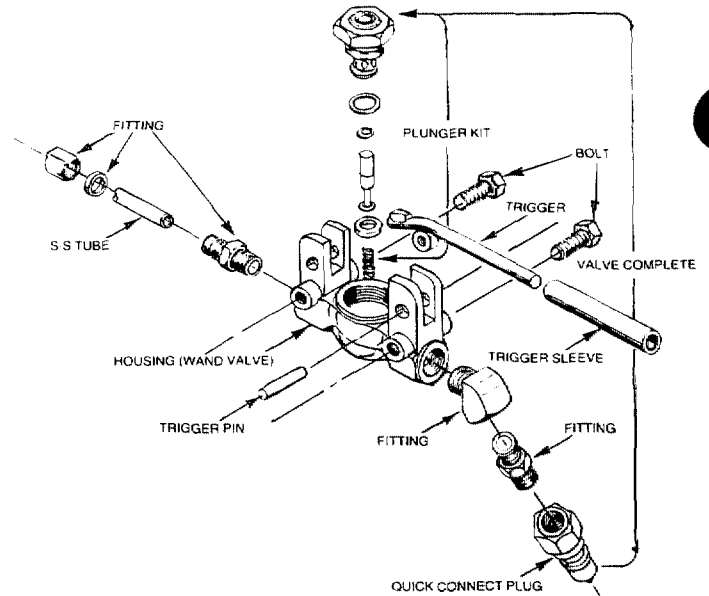

OPERATING INSTRUCTIONS

START UP

1. Perform daily/periodic maintenance as specified by the owner's manual.
2. Connect all required hoses.
3. Connect cleaning tool to length of hose required to perform cleaning.
4. **Caution:** Mix tank must be full prior to ignition.
5. Start engine (choke as required). Engine is at operating speed (recommended - 2600 RPM). Allow warm-up period of 2 - 5 minutes.
6. Spray wand to void all air from system. As the mix tank is in a fill cycle, the chemical flow meter may be adjusted to your desired setting. **NOTE:** Recommended carpet cleaning pressure is 250 - 300 PSI.
7. Once all air is voided from system, heater may be ignited. **NOTE:** If not familiar with operation of this heater, refer to heater section of the manual.
 - A. Open propane valve on the tank.
 - B. Ignite pilot on the heater.
 - C. To ignite burner, turn dial to **on** position.**NOTE:** If you suspect that the unit has been frozen - **DO NOT** light the heater. Thaw the heater and check for leaks.
8. Turn on burner, adjust dial to normal or slightly below for 200 Deg. F.
9. Commence cleaning operation
NOTE: Chemical flow meter set at 5 GPM is a 1 to 30 mix ratio and 10 GPH is 1 to 15 ratio. When flow meter is set at 10 GPH, you will be using what most chemical manufacturers recommend at 5 GPH.

SHUT DOWN

1. Turn heater to off position. Spray wand for a least 3 minutes to allow the heater coils to cool.
2. Close valve on propane tank.
3. Remove vacuum hose.
4. Flush clear water through chemical system for 10 seconds. (vinegar should be rinsed through system weekly). Turn off chemical flow meter.
5. Turn on cleaning tool to flush chemical from unit hoses and cleaning tool.
NOTE: If freeze guard is necessary, perform steps 1 & 2 of freeze guard procedure at this time.
6. At this time, the blower should be lubricated with LPS 1 or WD 40.
7. Shut engine down.
8. Drain vacuum tank. Vacuum filter should be cleaned prior to mobilization of van.
NOTE: If freeze guard is necessary, perform steps 3 - 9 of freeze guard procedure at this time.

MACHINE CONTROL PANEL

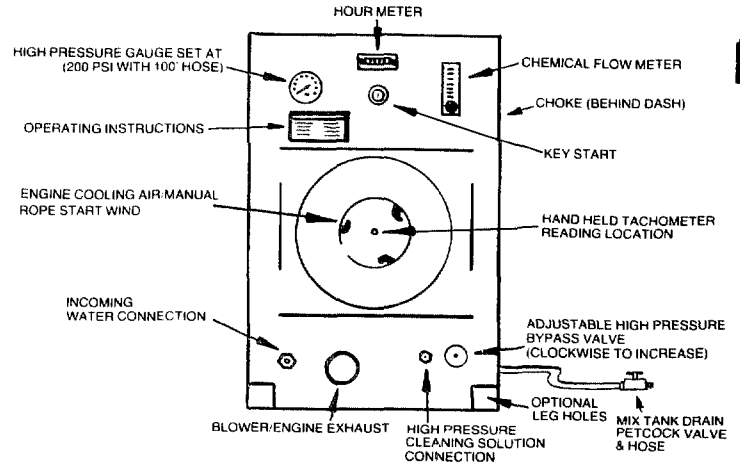

OPERATION PRECAUTIONS

MACHINE ADJUSTMENTS:

Although this unit has been factory adjusted, it may require additional adjustments to achieve optimum performance; i.e. altitude may require carb adjustment and ambient temperatures may require heat control adjustment. When required, consult an authorized representative.

ENGINE COOLING:

CAUTION Units employing air cooled engines must not be incapacitated within a van with doors and windows closed. Excessive temperatures within the engine will result in premature engine failure and a compromise of applicable warranty.

LEVEL OPERATION:

CAUTION During operation, van or trailer must be parked on level ground not to exceed + or - 10 deg.. Failure to insure proper leveling may prevent proper internal lubrication of engine, vacuum and/or high pressure components.

FREEZE PROTECTION:

CAUTION Mother nature gives little warning as to her cold spells. Therefore, protecting this equipment from freezing will save costly down-time. Placing an electric heater in the truck or parking the truck indoors, will help to insure against freezing.

LIGHTING HEATER:

WARNING Never put your face down close to the opening of the heater when lighting.

STRONG PROPANE ODOR:

WARNING Never light the heater if you smell a strong odor of propane around the heater.

HEATER:

CAUTION Never pile things around the heater, i.e. hoses, boxes, chemical jugs, etc., as this will block the flow of air required for a clean burning heater.

OPEN FLAME:

CAUTION Remember that this heater is an open flame, therefore, do not remove engine gas line while troubleshooting or store any flammable material in the truck with heater operating.

FREEZE PROTECTION

Any freezing of this machine is not covered by warranty and during the colder months of operation, careful protection should be of utmost concern.

THE FOLLOWING PRECAUTIONS ARE RECOMMENDED:

1. Run machine before leaving for the first job to insure nothing has frozen the night before, including hoses and wand.
2. Insulate the garden hose from the cold ground by running it through an extra 1 1/2 inch vacuum hose.
3. Leave truck doors closed until time cleaning begins, then open slightly for ventilation of air cooled engine.
4. On extremely cold days propane does not vaporize as quickly, therefore, venting the warm exhaust over to blow on the propane tank will stabilize the propane flow. (This is necessary if you notice a drop in heat or a low burning flame in the heater.)
5. In colder climates, insulating the truck walls and floor boards will help protect the unit.
6. Don't procrastinate during the cleaning operation or the hot water solution line will also freeze on the ground. The solution line should be insulated in extremely cold climates.
7. Whenever possible, the truck and machine should be stored in a heated garage at night or over the weekend. If not possible, place a 1500 watt electric heater inside the truck, aimed directly at the machine. Never use a propane heater - it causes excessive moisture on the truck ceiling and the possibility of it going out is higher. If the machine and truck are left outside with a heater, you should first drain all possible water from the machine cleaning tools and hoses. (They freeze also.)

TO DRAIN THE MACHINE, FOLLOW THESE STEPS:

- A. Before shutting off the machine, remove the chemical line from the chemical jug and place in a mixture of 50/50 anti-freeze and water. With the cleaning tool on, allow mixture to fill chemical system back to the chemical mix tank.
- B. Loosen the petcock valve on your bypass drain hose and allow the water to drain thoroughly from the mix tank.
- C. To remove the water from the heater and pump use the freeze guard kit which is a small air compressor that can be plugged into the dash board lighter in the truck, or air at the gas station. Using the correct connectors, first blow air into the high pressure solution male quick connect. This will force the water through the heater back through the pump and into the chemical mix tank to be drained out through the petcock valve to the ground.

Next, blow the air into the incoming water quick connect and force that water into the chemical mix tank to be drained out.

To be sure all water is out of the system, alternate between quick connectors several times.

8. **BE SURE IT'S PROTECTED!**
Freezing will cause **GRIEF, MONEY and DOWN-TIME. Don't mess with mother nature! Remember to close the petcock valve prior to next operation of your BobCat 2/290.**

CLEANING AND CHEMICAL PRECAUTIONS INFORMATION

Your mobile carpet cleaning plant has been engineered using the latest and most sophisticated technology available, to produce the finest carpet cleaning results possible. Despite this however, it remains only a tool of the carpet cleaning trade, and it can produce only as good a job as the person operating it.

There are no short cuts to good carpet cleaning, it requires time, cleaning knowledge and the use of good chemicals.

Manufacturer recommends the use of spotting agents, and traffic lane cleaners prior to the actual cleaning of carpeting, as required.

Manufacturer recommends setting heater thermostat at 'normal' setting when cleaning synthetic fiber carpets, and at 'warm' setting when cleaning natural fiber carpets.

CAUTION When cleaning cut-pile acrilan plush carpets, set heater at 'warm' setting. Using higher heater setting may result in fiber damage on this type of carpet.

The use of some chemicals through your mobile carpet cleaning plant can seriously damage the internal plumbing, high pressure pump and heater. (Chemicals such as concentrated acids and some paint oil and grease removers w/high concentration of solvents.)

Manufacturer recommends only the use of chemicals containing rust and corrosion inhibitors and water softening agents to prevent chemical build-up.

NOTE:

At no time should a chemical solution with a PH of less than 7 or higher than 10 be used in the unit.

PH CHART

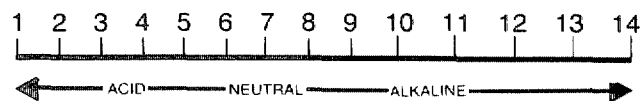

CLEANING STROKE PROCEDURE/OVER-WETTING

PURPOSE:

To eliminate excess moisture remaining in the carpet fiber and the sawtooth appearance which results from diagonal movement of the cleaning tool on all types of carpet.

PROCEDURE:

Always move the cleaning tool in smooth forward and backward strokes. Apply **slight** pressure to the forward stroke while the solution is injected into the carpet. When extracting (drying), apply firm pressure on the forward stroke to ensure a positive "lock" for the vacuum and minimize the "hopping" effect resulting on unsmooth carpet. During the forward and reverse strokes, movement to the

right or left should only be accomplished at the extreme rear of the stroke. Overlapping is also important to ensure even application of solution to prevent saturation when cleaning wand is stopped twice at the same point at the rear of the cleaning stroke.

Failure to adopt this procedure can result in increased chance of "clean streaks", fiber shrinkage, brown out, and longer drying periods.

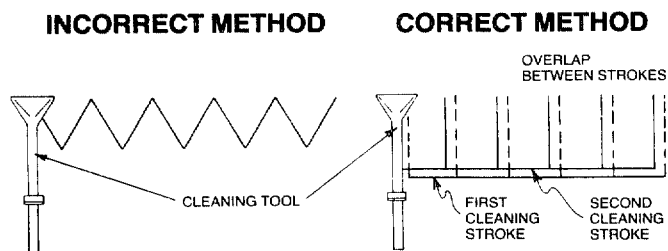

OVER-WETTING

Over-wetting is annoying to all concerned and sometimes leaves a bad impression of the cleaning process used.

There are several areas that will cause over-wetting:

1. Too few vacuum strokes or improper saw tooth vacuum strokes as shown above.
2. Obstructed, kinked or cut hoses.
3. Vacuum tank drain valve left partially open.
4. Clogged vacuum blower filter or vacuum tank lid not sealing properly.
5. Cleaning a heavily foam-saturated carpet without defoamer. (We recommend crystal type.)

MAINTENANCE PROCEDURES

To avoid costly repairs and down-time, it is imperative to develop and practice good maintenance procedures from the beginning. These procedures fall into daily, weekly, monthly and quarterly increments, and are outlined below. We have provided a maintenance log for your convenience on the following pages; it is recommended that you affix a copy of the log on the vehicle door near your unit for convenience and to serve as a maintenance reminder.

DAILY

- Check engine oil level.
- Inspect garden hose screen - clean as needed.
- Visually inspect machine for loose wires, oil leaks, water leaks, etc..
- Inspect recovery tank s/s filter and filter bag for tears, holes, etc. - clean, repair or replace as needed.
- Lubricate blower with LPS-1 or WD-40 through blower inlet.

WEEKLY

- Change engine oil. (25-30 hours of operation)
- Check engine air cleaner filter - clean as necessary.
- Check high pressure pump oil - add as necessary.
- Check drive coupler set screws - tighten as needed.
- Check pump drive belt for wear - tighten as needed.
- Check pump pulleys - tighten as needed.
- Check fuel lines for wear/chafing.
- Check all nuts and bolts - tighten as needed.
- Check heater burner assy. union for tightness/leaks.

- Clean vacuum tank thoroughly with high pressure washer.
- Flush water and chemical system with 50/50 white vinegar solution.
- Check engine RPM's - adjust to 2600 RPM's as needed.

IMPORTANT: Record date and machine hours on maintenance chart.

MONTHLY

- Grease blower bearing fittings.
 - Remove, clean and reinstall engine air cleaner filter.
 - Remove pressure by pass valve stem, grease cup and stem, reinstall.
 - Check water level in battery. Clean connections as needed.
- IMPORTANT:** Record date and machine hours on maintenance chart.

QUARTERLY

- Change oil in blower (see blower manual).
 - Check engine compression.
 - Check for combustion chamber carbon deposit
 - Change spark plugs (see engine manual).
- Take to authorized Briggs & Stratton dealer

OVERALL CARE OF UNIT

MAINTAINING THE ORIGINAL APPEARANCE OF YOUR UNIT IS IMPORTANT FOR TWO REASONS:

1. It represents a big dollar investment for your cleaning business and its appearance should reflect that fact. A dirty machine is not professional!
2. Maintenance, troubleshooting, and repair is much easier to accomplish on a clean well maintained unit. Regular cleaning of the machine offers you an opportunity to visually inspect all facets of the machine and spot potential problems before they occur.

FOLLOWING MAINTENANCE IS RECOMMENDED BY THE MANUFACTURER AT THE FREQUENCY INDICATED.

AFTER EACH JOB: Check recovery tank, s/s filter and filter bag as required.

DAILY: Wipe machine down thoroughly with a damp cloth; flush recovery tank out thoroughly. Empty filter bag and inspect for rips, tears, etc. - replace as needed; remove, thoroughly clean and reinstall stainless steel filter screen in recovery tank; inspect and clean vacuum slot on cleaning wand; check wand head for sharp edges that could tear carpet - file down as needed; clean wand with stainless steel cleaning compound to maintain original appearance (available through grocery stores); wipe down vacuum and high pressure hoses as needed - visually inspect for cuts, etc..

WEEKLY: Wipe down entire unit as needed - apply good coat of auto wax to all painted surfaces inside and out, and to control panel; thoroughly clean recovery tank using high pressure hot water (unit with optional high pressure cleaning gun may be used for this); remove stainless steel filter in recovery tank, thoroughly clean removing all lint build-up, inspect for damage and reinstall. Remove filter bag, thoroughly clean and reinstall - if torn, replace; empty chemical from chemical container, wash out thoroughly to remove any chemical build-up; inspect chemical feed line strainer and use 50% white vinegar/water solution to remove any chemical build-up; thoroughly clean wand and inspect for clogged jet, debris in vacuum slot and leaking fittings at valve. Apply light coat of auto wax to wand; thoroughly clean vacuum and high pressure hoses including hose cuffs - inspect for wear or damage to hoses and quick connect fittings. Inspect garden hose connect/adaptor screen for debris, remove and clean thoroughly. Inspect all propane and gas lines for wear or abrasions that may cause possible fuel leaks.

