

70 Gallon Fresh Water Tank Owner's Guide

HydraMaster
11015 47th Avenue West
Mukilteo, Washington 98275

MAN-45641 Rev. 1, March 28, 2013
(182-887)

No part of this manual may be reproduced or used in any form or by any means (i.e. graphic, electronic, photocopying or electronic retrieval systems) without the express written permission of HydraMaster. Specifications and information in this document are subject to change without prior notice. All rights reserved. © 2013 HydraMaster

This page is intentionally left blank.

70 GALLON FRESH WATER TANK

Table of Contents

GENERAL INFORMATION.....	SECTION 1
Contact Information.....	1-3
Warnings, Cautions and Notices.....	1-4
Tank Specifications	1-7
Responsibilities	1-8
Local Water Precautions.....	1-9
INSTALLATION INSTRUCTIONS	SECTION 2
Installing the 70 Gallon FWT into Vehicle	2-1
OPERATING AND MAINTENANCE INSTRUCTIONS.....	SECTION 3
Filling the Tank	3-1
Maintenance.....	3-1
Freeze Guarding	3-2
ASSEMBLY AND PARTS LIST.....	SECTION 4
70 Gallon Fresh Water Tank Assembly Parts List.....	4-3
HOW TO ORDER PARTS	SECTION 5
Warranty Parts Orders	5-1
Parts Orders.....	5-1
Emergencies	5-1
WARRANTY INFORMATION	SECTION 6
Pump	6-1
Hoses	6-1
Hard Water Deposits.....	6-1
Warranty Procedure	6-1
ACCESSORIES AND CHEMICAL SOLUTIONS.....	SECTION 7

70 GALLON FRESH WATER TANK

List of Figures

Figure 1-1. Major Components of the 70 Gallon FWT.....	1-6
Figure 1-2. Hard Water Map of Mainland United States.....	1-10
Figure 2-1. Hole Patterns for Boxxer 318/323/432S and Boxxer 421	2-1
Figure 2-2. Load FWT into Vehicle until Truckmount Is In Place.....	2-2
Figure 2-3. Use Forklift to Position Machine.....	2-2
Figure 2-4. Drill a 1-1/2” Hole for Overflow Hose Behind Tank.....	2-3
Figure 4-1. 70 Gallon Fresh Water Tank Assembly - View 1 of 2	4-1
Figure 4-2. 70 Gallon Fresh Water Tank Assembly - View 2 of 2	4-2

70 GALLON FRESH WATER TANK

1- General Information

HydraMaster has extended its fresh water tank product selection with the addition of the new 70 gallon Fresh Water Tank (FWT).



The 70 gallon FWT features a compact horizontal design, making it convenient to mount the tank underneath the Boxxer 318, the Boxxer 323, Boxxer 421 or the Boxxer 423S.

The full assembly includes

- a white rotomolded tank which allows you to see the water level
- a steel frame which can fully support a Boxxer 318, Boxxer 323, Boxxer 421 or Boxxer 423S
- a pump which provides steady water pressure and smooth water flow
- all the necessary fittings and hoses

Although the 70 gallon FWT has been designed and built to give you years of reliable service, it still requires proper installation and operation, as well as regular maintenance. This Owner's Guide contains installation and operation instructions, and information required for proper maintenance. Please follow the instructions carefully and you will be rewarded with years of profitable, trouble-free operation.

70 GALLON FRESH WATER TANK

It is imperative that no section be overlooked when preparing for operation of this equipment.

This section of the guide contains the following helpful information. If you are viewing the digital version of the manual, click on the bulleted items to access those subsections.

- [Contact Information](#)
- [Warnings, Cautions and Notices](#)
- [Standard Tank Configuration](#)
- [Responsibilities](#)
- [Local Water Precautions](#)

70 GALLON FRESH WATER TANK

CONTACT INFORMATION

If you have any questions regarding the operation, maintenance or repair of this machine, please contact your local distributor.

To find a local distributor, please visit our website at <http://hydramaster.com/HowToBuy/DealerLocator.aspx>

If your question cannot be resolved by your distributor or by the information within this manual, you may contact HydraMaster direct using the following phone numbers.

HOURS	TELEPHONE NUMBERS	E-MAIL ADDRESSES
Monday-Friday 7:00 a.m. to 5:00 p.m. Pacific Standard Time	Technical Support (425) 775-7275 FAX : (800) 426-4225	Technical Support techsupport@hydramaster.com
	Customer Service/Parts (425) 775-7276 FAX: (425) 771-7156	Customer Service/Parts parts@hydramaster.com

When calling your distributor, be sure to reference the date of purchase.

FOR YOUR REFERENCE:

Date of Purchase: _____

Purchased From (Distributor): _____

70 GALLON FRESH WATER TANK

WARNINGS, CAUTIONS AND NOTICES

WARNING

HydraMaster uses this WARNING symbol throughout the guide to warn of possible injury or death.

CAUTION

This CAUTION symbol is used to warn of possible equipment damage.

NOTICE

This NOTICE symbol indicates that federal or state regulatory laws may apply, and also emphasizes supplemental information.

70 GALLON FRESH WATER TANK

Warnings and Cautions specific to the 70 gallon FWT include:

⚠ WARNING

HEARING PROTECTION: The Occupational Safety and Health Administration (OSHA) recommends the use of hearing protection when a technician is exposed to an average of 85 decibels (this is an average of exposure over an 8-hour period). The carpet cleaning equipment used in conjunction with the 70 gallon FWT can produce sound levels as high as 85 decibels to a distance of 10 ft (3 m). Please check with your local state agencies to see if OSHA standards apply to your application.

⚠ WARNING

MOVING PARTS: Never touch any part of the tank assembly or the machine that is in motion. Severe bodily injury may result.

⚠ WARNING

SECURING TANK TO VEHICLE: When the 70 gallon FWT is full of water, the tank can weigh more than a 750 lbs (340 kg). A sudden or crash stop will cause the machine to rocket forward if not properly secured. To prevent serious personal injury, ensure that the tank is well secured to the floor of the vehicle with the hardware supplied. Protect yourself and the machine.

CAUTION

HARD WATER PROTECTION: Failure to take appropriate measures to prevent scale build up can result in system failure and loss of warranty on affected parts. Test the water in your immediate and surrounding areas with hard water test strips. Assume all water obtained from wells is hard. If you are operating in a hard water area at 3.0 grains or more per gallon, use a water softening system.

CAUTION

FREEZE PROTECTION: Failure to take appropriate measures to prevent equipment damage due to freezing can result in system failure and loss of warranty on affected parts.

70 GALLON FRESH WATER TANK

ANGLED VIEW OF FWT

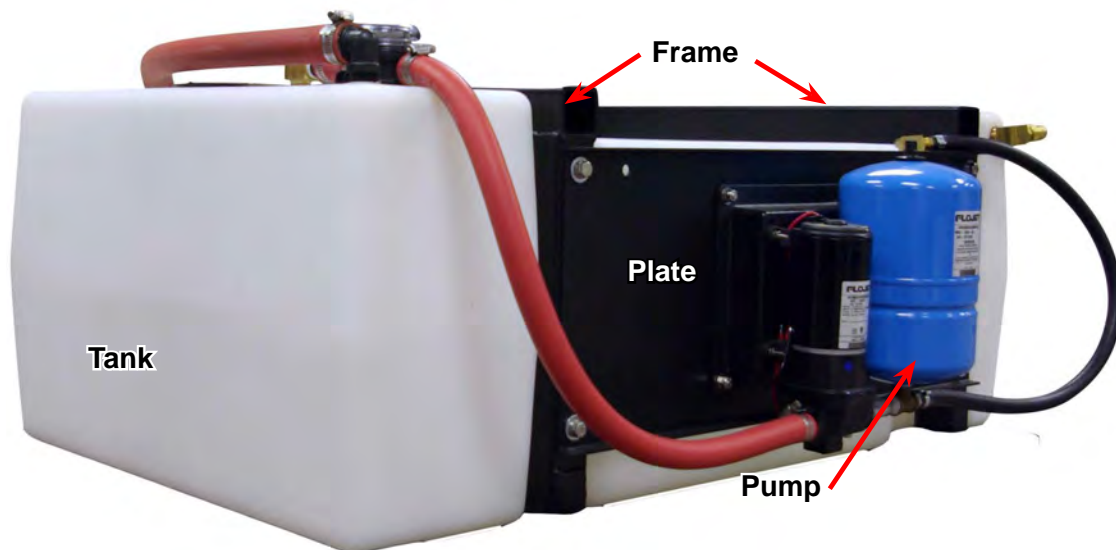

TOP DOWN VIEW OF FWT

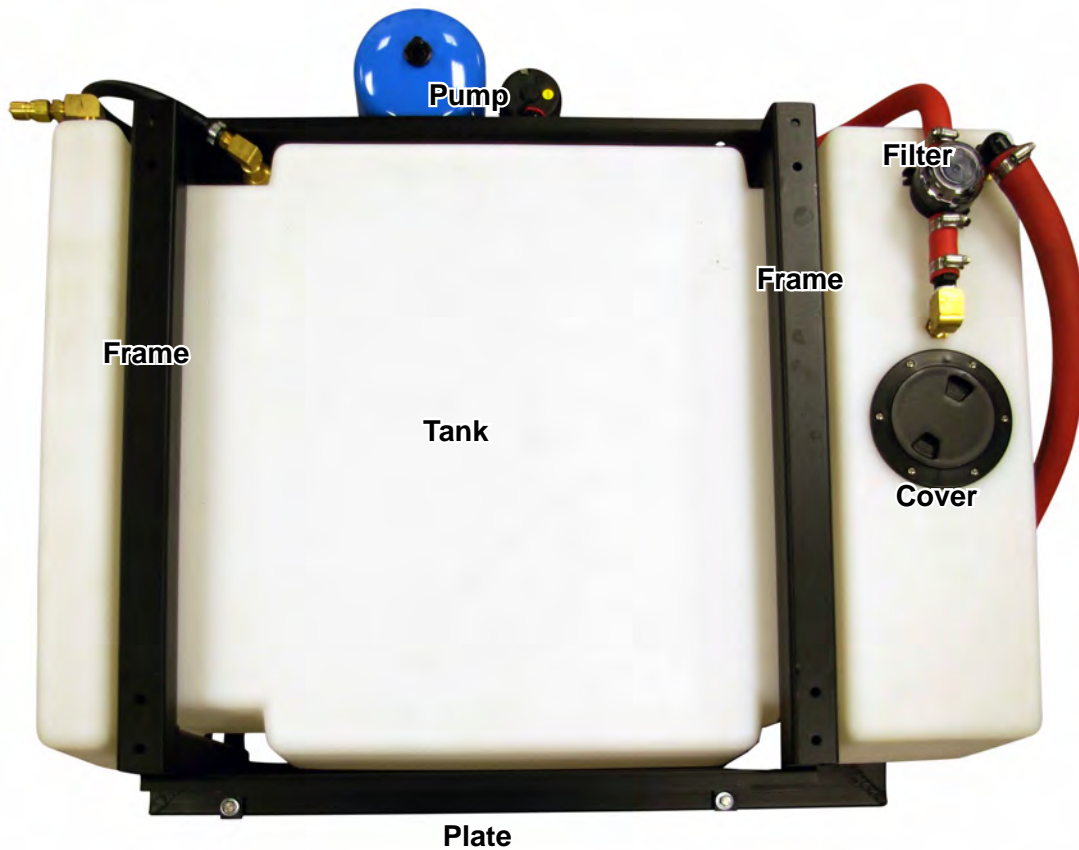

Figure 1-1. Major Components of the 70 Gallon FWT

70 GALLON FRESH WATER TANK

TANK SPECIFICATIONS

Tank Capacity	70 gallons (265 litres)
Tank Construction	Rotomolded LLDPE *
Mounting Components	Powder coated steel
Dimensions	16 7/8" H x 42.5" L x 30" W (43 cm x 108 cm x 76.2 cm)
Weight (Dry)	130 lbs. (59 kg)

* LLDPE = Linear Low Density Polyethylene

70 GALLON FRESH WATER TANK

RESPONSIBILITIES

Prior to the arrival of the unit, the vehicle in which the 70 gallon FWT will be installed should be delivered to the installer.

Purchaser's Responsibility

If you are the purchaser, it is your responsibility to read this Owner's Manual and to familiarize yourself with the information contained herein, paying special attention to all Warnings and Cautions.

Sales Representative's Responsibility

Acceptance of Shipment

1. If the 70 gallon FWT shows any outward signs of damage, do not sign the delivery receipt until you have closely inspected the unit and noted any damage on the delivery receipt.
2. The sales representative from whom you purchased your 70 gallon FWT is responsible for supervising the correct installation of the unit into your vehicle and thoroughly training you in its operation, maintenance and precautions.

Installation

- Correctly installing the 70 gallon FWT in your vehicle and securing it with bolts and tie down washers.
- Checking all water and vacuum connections including the vacuum reel rotation prior to starting the carpet cleaning unit.
- Checking all hoses, tools/wands and accessories for correct operation.

Training

- A thorough review of the Owner's Manual with the purchaser.
- Instruction in and familiarization with:
 1. How to correctly fill and drain the tank.
 2. How to correctly clean the tank.
 3. How the unit's systems work, how to troubleshoot the tank.
 4. How to do basic repairs.
 5. Safety precautions and their importance
 6. How to avoid freezing damage
 7. How to avoid hard water damage
- A thorough review of the unit warranty and warranty procedures.
- A thorough review of hard water precautions and warnings.
- How to determine hard water areas.
- Use of water softening systems.

70 GALLON FRESH WATER TANK

LOCAL WATER PRECAUTIONS

The quality of water varies greatly. Many areas have an excess of minerals in the water which results in what is commonly called “hard water.” These minerals tend to adhere to the insides of heater coils and other parts of the machines causing damage and a loss of cleaning effectiveness. This influences the reliability and efficiency of equipment in direct proportion to the level of hardness.

Hard Water Advisory

HydraMaster recognizes that any hard water deposits which might occur within the water system of our truckmounts and tanks is a serious problem. Hard water deposits will ultimately decrease the performance of the system and are expected to seriously lower the reliability of the machine.

To validate a machine’s warranty, HydraMaster requires that all machines operating in designated “Hard Water Areas” (3.0 grains or more per gallon) be fitted with a water softening system, or a properly installed magnetic-type descaler must be used and maintained. Periodic descaling or acid-rinsing alone is not adequate in these areas. HydraMaster does not recommend any particular type or brand; however, the relative effectiveness of some types of magnetic descalers or softeners may require additional periodic use of descaling agents.

HydraMaster also recommends, in the strongest possible terms, that machines in all areas be fitted with a water softening system for improved operation and reliability.

CAUTION

Failure to take appropriate measures to prevent scale build up can result in system failure and loss of warranty on affected parts.

70 GALLON FRESH WATER TANK

Hard Water Area Map

The hard water map, shown in Figure 1-2, defines hard water areas in the lower 48 United States which compromise fluid related components such as hoses, fittings, pumps, and valves. For other countries, hard water area maps can be obtained from geological societies.

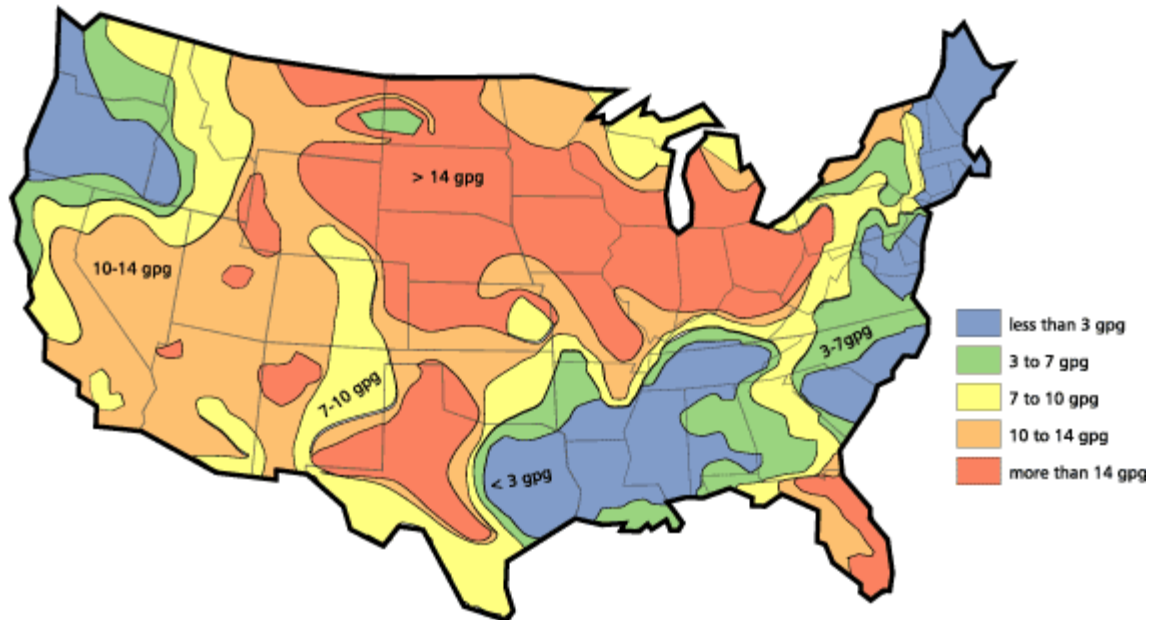

Figure 1-2. Hard Water Map of Mainland United States

NOTICE

The map shown in Figure 1-2 is provided for general reference only. Water hardness in your geographical location should be confirmed by testing.

70 GALLON FRESH WATER TANK

Water Softener

Cleaning efficiency and equipment life is increased, chemical use decreased, and the appearance of cleaned carpets enhanced when water softeners are incorporated in hard water areas. HydraMaster strongly urges the use of water softener units with the 70 gallon FWT in areas exceeding 3.0 grains per gallon (3.78 litres).

Failure to use a water softener in these areas will invalidate the tank's warranty. Referring to the hard water area map shown Figure 1-2, determine the quality of water in your area and take immediate action if the water hardness exceeds 3.0 grains per gallon.

The relatively low cost of a water softener service is more than made up for by an increased life of machine parts, reduced chemical costs and continued cleaning efficiency. The water softener will also increase the effectiveness of the cleaning chemicals, therefore less chemical will be needed.

For example: If the softener will treat 900 gallons (3.04 kilolitres) of water and the machine uses an average of 30 gallons (113.6 litres) per hour, for an average of 5 hours a day, this equals 150 gallons (568 litres) per day. In 6 days the machine would use 900 gallons of water. Therefore, the softener would need to be charged every 6 working days for maximum softening.

Contact a water softener distributor in your area for information on the rental of a simple water treatment unit to carry in your vehicle. Be sure to charge the water softener in accordance with the capability of the softener.

70 GALLON FRESH WATER TANK

This page is intentionally left blank.

70 GALLON FRESH WATER TANK

2 - Installation Instructions

The 70 Gallon Fresh Water Tank has been designed to fit a variety of vehicle types and configurations. This section of the Owner's Guide provides general installation instructions based on just Ford and GM cargo van configurations. If the installation is not in a standard cargo van, it is advisable to dry fit the tank with the other equipment to verify everything fits properly.

⚠ WARNING

Use extreme caution in loading the 70 Gallon FWT into the van. Always seek the assistance of a second person. If you attempt to load the 70 Gallon FWT by yourself, personal injury can result.

INSTALLING THE 70 GALLON FWT INTO VEHICLE

1. Remove the FWT assembly from the pallet and verify that the frame is spaced to the proper location. For a Boxxer 318, 323, or 423S, the frame should be located to the outer hole pattern; for a Boxxer 421 the frame should be located to the inner hole pattern. By default, it will be set up for a Boxxer 318 (see Figure 2-1).

Boxxer 318/323/423S

Boxxer 421



Figure 2-1. Hole Patterns for Boxxer 318/323/423S and Boxxer 421

70 GALLON FRESH WATER TANK

2. Load it into the back of the vehicle temporarily until the truckmount is in place (see Figure 2-2).



Figure 2-2. Load FWT into Vehicle until Truckmount Is In Place

3. Temporarily place the recovery tank into the desired location.
4. Using a forklift, position the machine into the approximate installation location in the van. Lift the machine high enough so that the tank can be slid into the position underneath the machine (see Figure 2-3).



Figure 2-3. Use Forklift to Position Machine

5. Set the machine onto the tank and secure to the top rails using the supplied hardware. The Boxxer 318, Boxxer 323 and Boxxer 423S will use the outer holes and the Boxxer 421 will use the inner holes.

70 GALLON FRESH WATER TANK

6. With all items in place, you should locate the FWT and machine just to the edge of the plastic door step. The side-to-side orientation should be close enough to the front of the vehicle to allow all of the recovery tank floats, dump valve and APO enough clearance so that they do not interfere with the FWT or the machine. It may be necessary to move the recovery tank to allow for this clearance.
7. Connect the recovery tank to the blower using the supplied flexible hard wall hose that came with the machine. It may be necessary to move the tank temporarily to allow for the hose to be attached, then it can be placed into its final position.
8. Close the door of the van to verify that the machine and the tank do not make contact.
9. Mark the location of the 4 holes on the van floor, checking under the van to ensure that, when you drill through the van floor, you are not drilling through the fuel line or other components.

CAUTION

THROUGH-FLOOR DRILLING: Be careful when drilling holes through the van floor. Many vans have critical components mounted directly below the van floor which could be damaged by a misplaced drill bit.

10. Once everything is positioned, secure the FWT and recovery tank using the supplied hardware. It may be necessary to add plates to the bottom of the bracket in the event they are located over the troughs of the vehicle floor.

CAUTION

Failure to do so can place excessive pressure on the tank and potentially damage the tank.

11. Drill a 1-1/2" hole for the 1" overflow hose behind the tank. Verify that the hose has a smooth bend and is **NOT** kinked or restricted in any way. After the hose is inserted, seal the gap with silicone (Figure 2-4).

CAUTION

Any restriction in the overflow how can cause damage to the tank or vehicle.

12. Wire the pump to the Pump In wires from the main harness at the back of the machine.

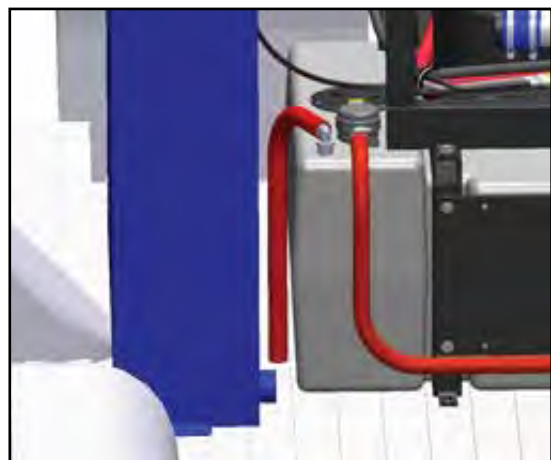

Figure 2-4. Drill a 1-1/2" Hole for Overflow Hose Behind Tank

70 GALLON FRESH WATER TANK

This page is intentionally left blank.

70 GALLON FRESH WATER TANK

3 - Operating and Maintenance Instructions

This section of the Owner's Guide includes information concerning:

- Filling the Tank
- Maintenance
- Freeze Guarding

CAUTION

When operating the 70 Gallon Fresh Water Tank during the colder months of the year, ensure that you properly freeze guard the system. Failure to take appropriate measures to prevent equipment damage due to freezing can result in system failure and loss of warranty on affected parts.

NOTICE

When the van is not in operation, placing an electric heater in the vehicle or parking the vehicle indoors will help ensure against freezing, but should not be the primary method of freeze protection

FILLING THE TANK

This process is very straight forward. All that is necessary is to attach the garden hose to the front male quick connect of the tank and turn on the water supply. When the water has reached the top of the tank, it will begin to overflow onto the ground. Disconnect the garden hose.

MAINTENANCE

Check the filter at the back of the tank weekly. It should be removed and cleaned if there is debris.

Periodically (1-2 times a year) inspect the inside of the tank through the access cover located at the top, towards the back of the tank.

1. Drain the tank
2. Remove any debris that has built up in the tank with a "wet" shop vac in case there is any residual water in the tank.
3. Check the 1" overflow hose and fitting to verify there are no obstructions.

CAUTION

Any restriction in the overflow how can cause damage to the tank or vehicle.

70 GALLON FRESH WATER TANK

FREEZE GUARDING

Water freezes at 32° F (0° C), but, to be on the safe side, you should protect your tank and hoses for any temperature below 35° F (1.67° C). When operating the tank during the colder months of the year, ensure that you properly freeze guard the system.

CAUTION

Failure to take appropriate measures to prevent equipment damage due to freezing can result in system failure and loss of warranty on affected parts.

Freeze Guarding Procedure:

1. Drain the remainder of the water in the tank by opening the drain valve.
2. Turn on the fresh water pump after the tank has been emptied to pump out any water in the hoses or pump.

NOTICE

In colder climates, insulating the vehicle walls and floor boards will help protect the equipment.

3. Whenever possible, store the van in a heated garage at night or over the weekend. If not possible, place a 1,500 Watt electric heater inside the vehicle, aimed directly at the equipment.

NOTICE

When the van is not in operation, placing an electric heater in the vehicle or parking the vehicle indoors will help ensure against freezing, but should not be the primary method of freeze protection.

70 GALLON FRESH WATER TANK

4 - Assembly and Parts List

This section shows the assembly and parts list associated with the 70 Gallon Fresh Water Tank.

Figure 4-1. 70 Gallon Fresh Water Tank Assembly - View 1 of 2
000-163-212

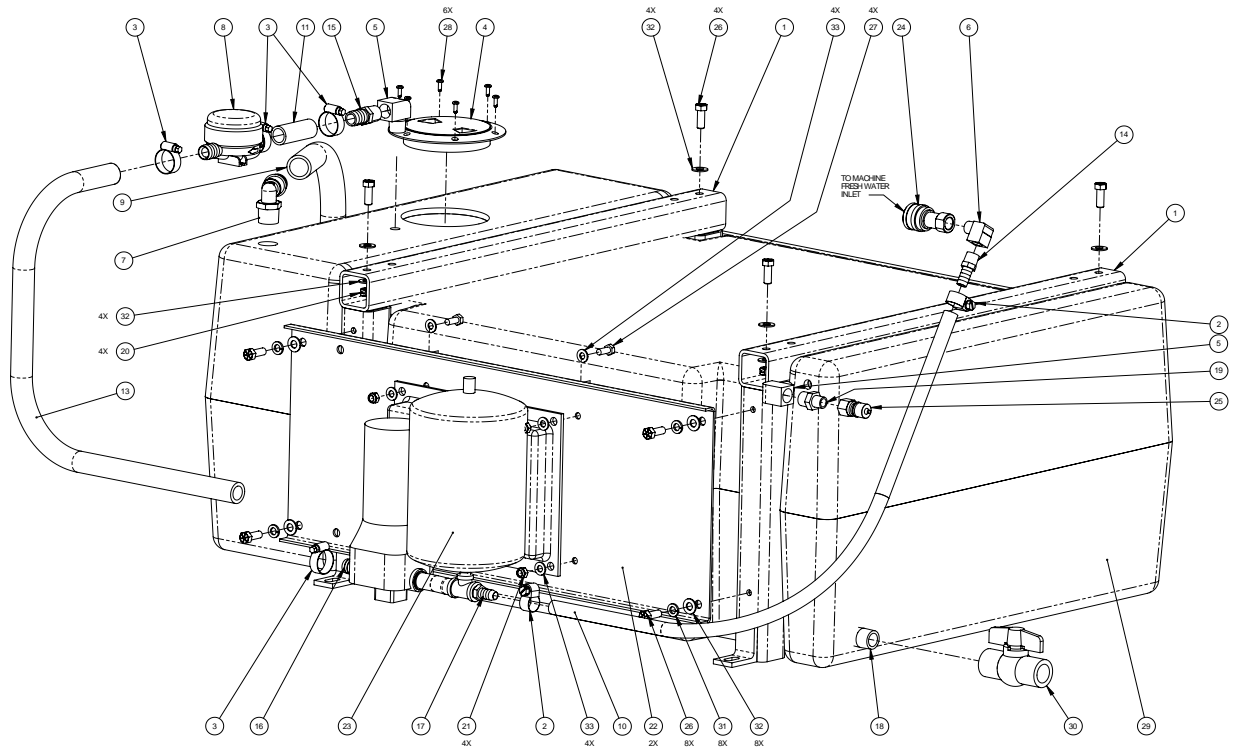

70 GALLON FRESH WATER TANK

Figure 4-2. 70 Gallon Fresh Water Tank Assembly - View 2 of 2
000-163-212

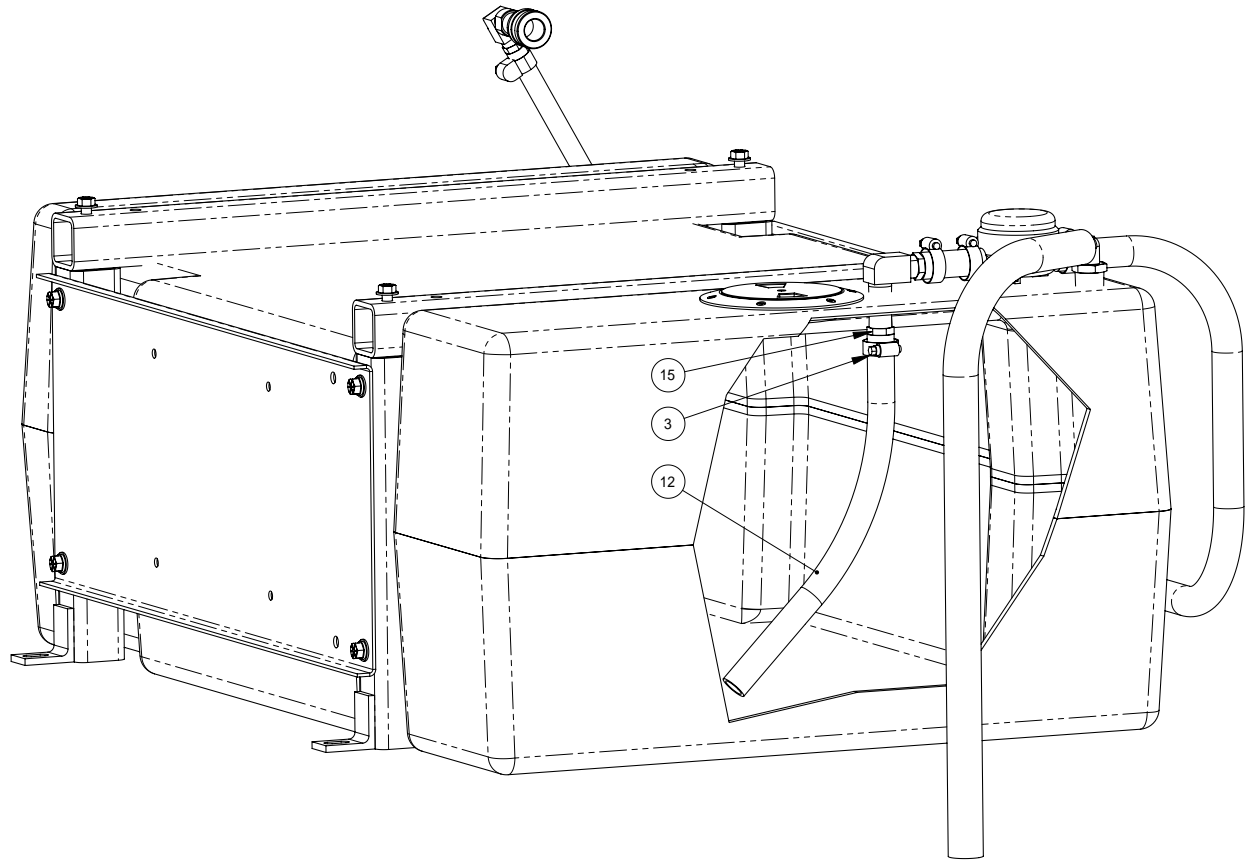

70 GALLON FRESH WATER TANK

70 Gallon Fresh Water Tank Assembly Parts List

Item	Part Number	Description	Qty
1	000-015-1238	Bracket, 70 FWT Mounting - Coated	2
2	000-033-004	Clamp, Size #6 Mini Hose	2
3	000-033-029	Clamp, Size #12 Hose	5
4	000-041-365	Cover, 4" Round	1
5	000-052-087	Elbow, 1/2" NPT Street	2
6	000-052-086	Elbow, 3/8" NPT Street	1
7	000-052-348	Elbow, 3/4" NPT X 1" Hose	1
8	- - -	Filter, Flojet Pump (Comes w\ 000-111-170)	1
9	000-068-964	Hose, 1" I.D. Rubber X 36" Lg. - Red	1
10	000-068-975	Hose, 1/2" I.D. Rubber X 32" Lg.	1
11	000-068-973	Hose, 3/4" I.D. Rubber X 2.5" Lg.	1
12	000-068-965	Hose, 3/4" I.D. Rubber X 16" Lg.	1
13	000-068-974	Hose, 3/4" I.D. Rubber X 30" Lg.	1
14	000-052-105	Insert, #68 (3/8" NPT X 1/2" Barb)	1
15	000-052-129	Insert, #812, 1/2 NPT X 3/4 Hose	2
16	- - -	Insert, Flojet Pump Inlet (Comes w/ 000-111-170)	1
17	- - -	Insert, Flojet Pump Outlet (Comes w/ 000-111-170)	1
18	000-052-326	Nipple, 3/4" NPT Close	1
19	000-052-075	Nipple, 3/8" NPT X 1/2" NPT	1
20	000-094-015	Nut, 3/8"-16UNC Hex 2-Way Locking	4
21	000-094-038	Nut, 5/16"-18UNC Nylock	4
22	000-105-668	Plate, Side - Coated	2
23	000-111-170	Pump, Flojet w/ Bladder 40 psi Fresh Water	1
24	000-052-053	Quick Connect, 3/8 Female	1
25	000-052-052	Quick Connect, 660 3/8" Brass w/ EPDM O-Ring	1
26	000-143-018	Screw, 3/8"-16UNC X 1" Lg. Hex Head - Grade 8	12
27	000-143-012	Screw, 5/16"-18UNC X 3/4" Lg.	4
28	000-143-314	Screw, #8 X 1/2" Lg. Pan Head	6
29	000-159-182	Tank, 70 Gallon Fresh Water Rotomolded	1
30	000-169-202	Valve, 3/4" FPT Ball Valve	1
31	000-174-021	Washer, 3/8" Lock	8
32	000-174-005	Washer, 3/8" Flat	16
33	000-174-049	Washer, 5/16" Flat	8

70 GALLON FRESH WATER TANK

This page is intentionally left blank.

5 - How to Order Parts

To order warranty replacement parts or repairs, it is important that you read this section which includes:

- Warranty Parts Orders
- Parts Orders
- Emergencies

WARRANTY PARTS ORDERS

1. Call the local distributor where you purchased your equipment and ask for the Service Department.
2. Have the following information ready:
 - a. Date of Purchase
 - b. Description of Malfunction
3. Once it has been determined which parts are needed to correct the problem with your machine, make arrangements with your distributor to either perform the repairs or ship the parts to you.

Any questions you have regarding the warranty program should be directed to the Customer Care Department at (425) 775-7275, 7 a.m. to 5 p.m. Monday through Friday (PT).

We shall always endeavor to be fair in our evaluation of your warranty claim and shall provide you with a complete analysis of our findings.

HydraMaster warranty covers only defective materials and/or workmanship for the periods listed. Diagnostic reimbursement is specifically excluded.

PARTS ORDERS

Call your local distributor. In most instances, they either stock or have access to parts through a regional service center.

EMERGENCIES

If, for any reason, your distributor is unable to supply you with the necessary parts, they may call us and arrange for expedited shipping.

HydraMaster sells parts only through authorized distributors and service centers.

70 GALLON FRESH WATER TANK

This page is intentionally left blank.

6 - Warranty Information

To avoid misunderstandings which might occur between machine owners and the manufacturer, we are listing causes of component failure that specifically voids warranty coverage. Such causes listed in this section shall constitute abuse or neglect.

PUMP

- Failure to protect pump-in pump against freezing.
- Failure to use water softener in hard water areas.

HOSES

- Failure to protect hoses against freezing.
- Failure to protect hoses against burns from engine and blower exhaust.
- Damage to hoses from being run over by vehicles.
- Kinking or cracking from failure to store or unroll hoses correctly.
- Normal wear and tear from everyday use.

HARD WATER DEPOSITS

- Failure to use or maintain a water softening system or a properly installed magnetic-type descaler, whichever might be necessary, with machines operating in designated "Hard Water Areas" (3.0 grains or more per gallon).

WARRANTY PROCEDURE

Warranty coverage is available to you through your local distributor. Please refer to the Golden Guarantee© Limited Warranty document shipped to you with the Owner's Guide. (You can also refer to <http://www.hydramaster.com/KnowledgeCenter/Warranty.aspx>).

If you have moved to a new area or have purchased a used machine and need information regarding your local distributor, call HydraMaster at (425) 775-7272 or email us at: techsupport@hydramaster.com.

When calling your distributor, be sure to have the machine's information, model and purchase date, ready for the service representative.

70 GALLON FRESH WATER TANK

This page is intentionally left blank.

7 - Accessories and Chemical Solutions

HydraMaster's machine accessories are the most innovative collection available in the cleaning industry.

The full line of machines, accessories and chemicals can enhance cleaning performance while reducing your labor costs, and include:

- Upholstery Tools
- Wands
- Vacuum Hoses
- Van Accessories
- Carpet Care Detergents
- Rinse Agents
- Pre-Sprays
- Hard Floor Care Detergents
- De-Foamers and Descalers
- Deodorizers and Disinfectants
- Spotting Agents

For more information, visit our website at www.hydramaster.com.

To order genuine HydraMaster accessories and chemical solutions, call your nearest authorized HydraMaster Distributor. (To find a local distributor, please visit our website at www.hydramaster.com/HowToBuy/DealerLocator.aspx).

70 GALLON FRESH WATER TANK

This page is intentionally left blank.