

HydraMaster[®]

Portable Extractors

THE ULTIMATE: PB111 EXTRACTOR

INFORMATION AND OPERATING INSTRUCTIONS

MODELS: PB111-120, PB111-120-SS

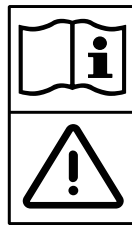
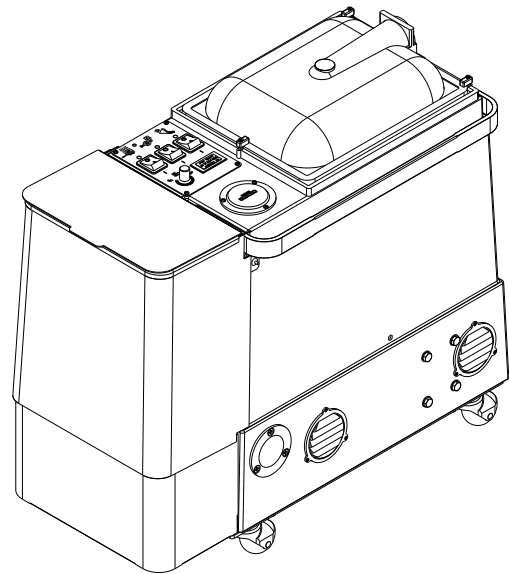

**CAUTION: DO NOT OPERATE MACHINE UNTIL YOU HAVE READ
ALL SECTIONS OF THIS INSTRUCTION MANUAL**



IMPROPER USE OF THE MACHINE WILL VOID THE WARRANTY

1. Never use the Booster Heat when solvent is in the machine.
2. Never attempt to heat solvent above 130 °F.
3. Always use a nonflammable solvent with a flash point of 140 °F or higher.



DO NOT SMOKE WHEN USING HYDROCARBON-BASED SOLVENTS.

Even solvents with a flash point above 140 °F can be ignited, especially as an aerosol from the wand.



4. The recovery bucket should be emptied each time the holding tank is filled.
5. Always make sure the float travels freely up and down the rod after emptying the recovery bucket.
6. Always vacuum out the stainless steel tank and solution lines when switching from a solvent to a water based detergent, and vice versa (see Operating Instructions).
7. Always use a drop cloth under the machine during operation.
8. Vacuum any unused solution out of the solution tank and empty the recovery bucket after each job.
9. Keep machine from rain and snow, extremes in temperatures, and store in a heated location.
Use the machine indoors. Do not use outdoors.
10. Do not run the pump dry.
11. Never operate a machine that is leaking or in need of a repair.
12. Always use a defoamer. The vacuum shut-off will not activate properly if foam is in the recovery bucket. Water damage to the vacuum motor or other components will void the warranty.

If you have any questions before you operate the machine, call your supplier for instruction.

INTRODUCTION

This manual will help you get the most from your equipment. Read it thoroughly before operating the machine.

This product is intended for commercial use only.

PARTS AND SERVICE

Repairs, when required, should be performed by your Authorized Service Center, who employs factory trained service personnel, and maintains an inventory of original replacement parts and accessories.

Call for repair parts or service. Please specify the Model and Serial Number when discussing your machine.

MODIFICATIONS

Modifications and additions to the cleaning machine which affect capacity and safe operation shall not be performed by the customer or user without prior written approval from the manufacturer. Unapproved modifications will void the machine warranty and make the customer liable for any resulting accidents.

NAMEPLATE

The Model and Serial Number of your machine are shown on the Nameplate. This information is needed when ordering repair parts for the machine. Use the space below to note the Model and Serial Number of your machine for future reference.

Model _____

Serial Number _____

UNPACKING THE MACHINE

When the machine is delivered, carefully inspect the shipping carton and the machine for damage. If damage is evident, save the shipping carton so that it can be inspected.

CLEANING SOLUTIONS:

The PB111 is capable of either wet or dry cleaning. Only liquid cleaners are recommended (no powders). Solvents with a flash point of 140° F or higher are required for safety. Solvents are normally used full strength. Water based cleaners are normally diluted. Follow label directions. The stainless steel holding tank can be filled with up to 3 gal. of cleaning solution.

WARNING!

The Products sold with this Manual contain or may contain chemicals that are known to certain governments (such as the State of California, as identified in its Proposition 65 Regulatory Warning Law) to cause cancer, birth defects or other reproductive harm. In certain locations (including the State of California) purchasers of these Products that place them in service at an employment job site or a publicly accessible space are required by regulation to make certain notices, warnings or disclosures regarding the chemicals that are or may be contained in the Products at or about such work sites. It is the purchaser's responsibility to know the content of, and to comply with, any laws and regulations relating to the use of these Products in such environments. The Manufacturer disclaims any responsibility to advise purchasers of any specific requirements that may be applicable to the use of the Products in such environments.

IMPORTANT SAFETY INSTRUCTIONS

This machine is only suitable for commercial use, for example in hotels, schools, hospitals, factories, shops and offices other than normal residential housekeeping purposes.

When using any electrical appliance, basic precautions should always be followed, including the following:

NOTE: Read all instructions before using this machine.

WARNING!

To reduce the risk of fire, electric shock, or injury:

- Do not leave the machine unattended when it is plugged in. Unplug the unit from the outlet when not in use and before servicing.
- To avoid electric shock, do not expose to rain or snow. Store, and use, indoors.
- Do not allow to be used as a toy. Close attention is necessary when used near children.
- Use only as described in this manual. Use only the manufacturer's recommended attachments.
- Never add water over 130° F/54° C to the solution tank.
- Do not use with damaged cord or plug. If the machine is not working as it should, has been dropped, damaged, left outdoors or dropped into water, return it to a service center.
- Do not pull by the cord, use the cord as a handle, close a door on the cord, or pull the cord around sharp edges or corners. Do not run the machine over the cord. Keep the cord away from heated surfaces. To unplug, grasp the plug, not the cord.
- Do not handle the plug, the cord or the machine with wet hands.
- Extension cords must be 12/3 and no longer than 50 feet. Replace the cord or unplug immediately if the ground prong becomes damaged.
- Do not put any object into openings. Do not use with any opening blocked; keep free of dust, lint, hair, and anything that may reduce air flow.
- Keep loose clothing, hair, fingers, and all parts of body away from openings and moving parts.
- Do not pick up anything that is burning or smoking, such as cigarettes, matches, or hot ashes, or any health endangering dusts. Do not use to pick up flammable or combustible liquids such as gasoline or use in areas where they may be present.
- Turn off all controls before unplugging.
- Use extra care when cleaning on stairs.
- Connect to a properly grounded outlet only.
- Liquid ejected at the spray nozzle could be dangerous as a result of its temperature, pressure, or chemical content.
- Use a respirator and gloves when using dry cleaning solvents. In addition, a fan or blower is helpful to blow fumes away from the operator.
- Always work in a well ventilated area.
- Always work with the exhaust hose attached to the machine when using solvents.

SAVE THESE INSTRUCTIONS

120VAC GROUNDING INSTRUCTIONS

This appliance must be grounded. If it should electrically malfunction, grounding provides a path of least resistance for electric current to reduce the risk of electric shock. This appliance is equipped with a cord having an equipment-grounding conductor and grounding plug. The plug must be plugged into an appropriate outlet that is properly installed and grounded in accordance with all local codes and ordinances.

⚠ DANGER!

Improper connection of the equipment-grounding conductor can result in a risk of electric shock. Check with a qualified electrician or service person if you are in doubt as to whether the outlet is properly grounded. Do not modify the plug provided with the appliance. If it will not fit the outlet, have a proper outlet installed by a qualified electrician.

This appliance is for use on a nominal 120-volt circuit, and has a grounding plug that looks like the plug illustrated in Figure 1 below. A temporary adapter illustrated in Figures 2 and 3 may be used to connect this plug to a 2-pole receptacle as shown in Figure 2 if a properly grounded outlet is not available. The temporary adapter should be used only until a properly grounded outlet (Figure 1) can be installed by a qualified electrician. The green-colored rigid ear, tab, or the like extending from the adapter must be connected to a permanent ground such as a properly grounded outlet box cover. Whenever the adapter is used, it must be held in place by a metal screw. Grounding adapters are not approved for use in Canada.

Replace the plug if the grounding pin is damaged or broken.

The Green (or Green/Yellow) wire in the cord is the grounding wire. When replacing a plug, this wire must be attached to the grounding pin only. Extension cords connected to this machine should be 12 gauge, three-wire cords with three-prong plugs and outlets. DO NOT use extension cords more than 50 feet (15 m) long.

PLEASE NOTE: FOR NORTH AMERICA ONLY

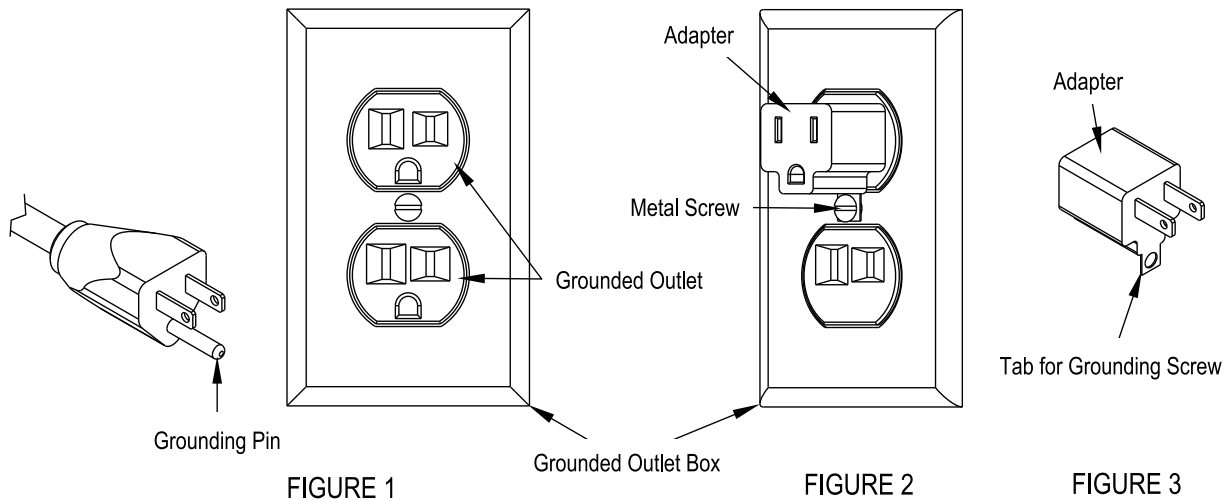

SET-UP:

- 1 Make sure the recovery bucket is in place under the dome and in the correct position. The dome must be flat or it won't seal properly.
 - 2 Fill the stainless steel holding tank with cleaning solution, to the desired level. Solution must be at least 3" above the filter in the bottom of the tank. **NOTE:** Attach the exhaust hose when dry cleaning.
 - 3 Position the cleaning tool over the holding tank, and depress the trigger. Turn the pump on (center switch). Allow the solution to spray for several seconds, to fill the lines.
 - 4 **SOLVENT HEATING:** turn on the Heater switch only. Make sure the Booster Heat switch is turned completely off. Wait two minutes for the heater to reach operating temperature. Spray over the holding tank again, for about 15 seconds, to preheat the solution line and the tool. **NOTE:** the heat will shut off completely if the Booster Heat is turned on with solvent in the tank. Go to Step 5.
WATER HEATING: turn on the Heater switch, and position the Booster switch to the desired temperature. Wait 2 minutes for the heater to reach operating temperature. Spray over the holding tank for 15 seconds to preheat the solution line and the tool. Wait 30 seconds, then spray again for 15 seconds. Go to Step 5.
 - 5 Turn on the Vacuum switch (first switch). All rocker switches should be turned on now. You are now ready to begin cleaning.
 - 6 When the recovery bucket is full, the vacuum will automatically shut off. Turn the vacuum switch off. Remove the dome and lift the bucket out. Empty the bucket, and wipe off any spillage from the outside of the bucket. Reinstall the recovery bucket and the dome.
 - 7 Make sure the float in the bucket travels freely up and down the rod each time you empty the recovery bucket.
- TO SWITCH CHEMICAL BASE**
- 8 When switching from a solvent-based product to a water-based detergent, or vice versa, use the following procedure: turn off all the switches, except the vacuum switch. Leave the vacuum hose in the dome, and disconnect the hoses from the tool. Place the open end of the vacuum hose into the solution tank, and vacuum out any remaining solution. Place the hose over the filter in the tank for 10 seconds.
 - 9 Connect the end of the solution line to the black suction plug. Take the vacuum hose out of the dome, and place the plug in its place. Let the vacuum run for 20 - 30 seconds to pull all the solution out of the lines and the heater. **NOTE: DO NOT LET THE PUMP RUN DRY.**

MAINTENANCE:

For optimum performance, flush the machine with clear water at the end of each working day. Once a month, minimum, run a flushing compound through the machine to break up any mineral or chemical build-up that may have formed. Clean the float rod each time the recovery bucket is emptied. Inspect the filters regularly and clean as needed. The vacuum filter is located under the recovery bucket. The solution filter is located at the bottom of the holding tank. The quick disconnects and castors can be lubricated with a penetrating spray lubricant. Fine steel wool will keep the brass quick disconnects shining. An auto interior spray cleaner/protectant will work well to keep the body clean and bright.

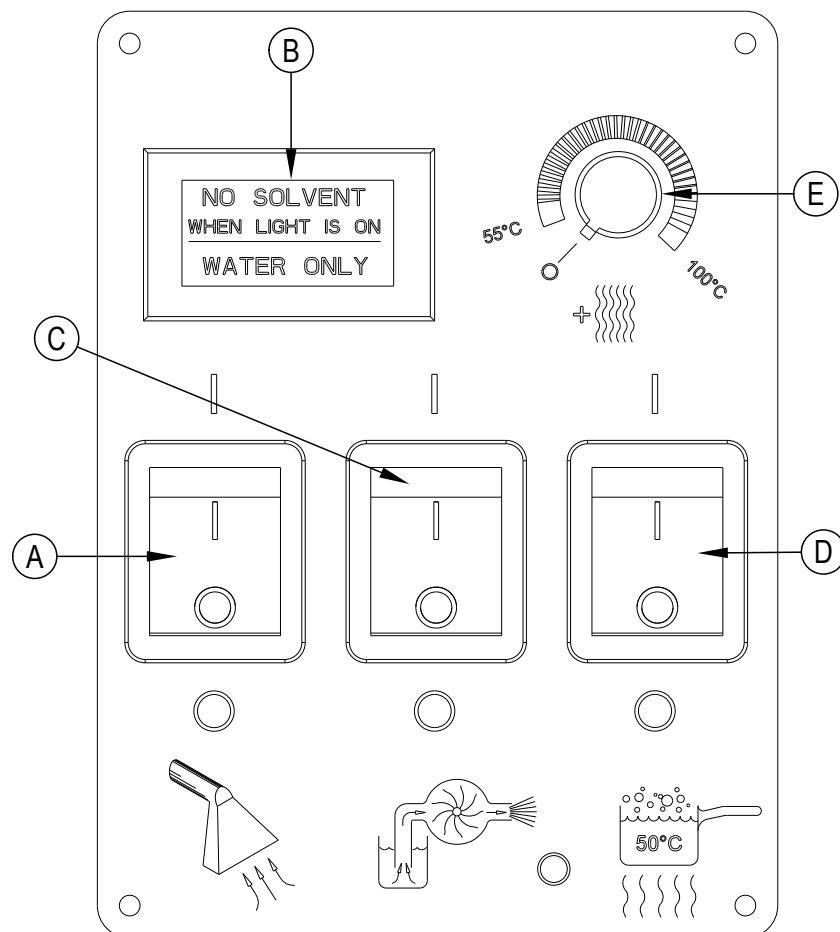

- A VACUUM
- B WARNING INDICATOR
- C PUMP
- D HEAT
- E BOOSTER HEAT

SOLVENT HEATING

Turn on the Heater Switch (D). The Booster Heat switch (E) must be all the way off (turned counterclockwise until it 'clicks' off) or the machine will not heat at all.

WATER HEATING

Turn on the Heater Switch (D). Turn on the Booster Heat Switch (E) to the desired temperature, 130° - 212°F (55° - 100°C)

NOTE: Booster Heat will not work unless the Heat switch is on.

WATER ONLY, NO SOLVENT (E)

This indicator light (B) illuminates when the Booster Heat switch (E) is turned on. It is a reminder that the Booster Heat will only work with water-based solutions.

⚠ CAUTION

USE A RAG TO DISCONNECT BRASS FITTINGS AFTER USING THE BOOSTER HEAT. THE FITTINGS CAN GET VERY HOT AND MAY CAUSE MINOR BURNS.

AUTO VAC SHUT-OFF

When the recovery bucket is full, the vacuum motor will automatically shut off. The float in the bucket may not be raised by foam. Defoamer must always be used to avoid water damage to the vacuum motor.

SOLVENT SENSING SYSTEM

This unique, patented system determines whether there is solvent or water-based solution in the tank. If solvent is used, the sensor will automatically prevent heating above 140 °F. To prevent accidental over-heating of solvent, the use of the Booster heat switch - with solvent in the tank - will cause the entire heat system to shut off.

SPECIFICATIONS AND FEATURES:

Construction:	Stainless steel and hexane copolymer for use with solvents and water based detergents
Vacuum:	80" water lift - 97 CFM
Heat Exchanger:	Stainless steel coil, instant heat transfer
Circuit Board:	Solid-state technology, long life monitoring system controls heating operation (sensing within 1° F)
Sensing Systems:	Solid state circuitry
Solvent Sensing Probe:	Determines whether there is solvent or water-base cleaning in holding tank. (Patented) Unique fail safe system automatically prevents solvent from heating above 140° F regardless of heat setting
Pump:	Centrifugal type 40 psi carbon and ceramic seals and brass head, slide-mount and compression fittings for quick removal and servicing
Electrical System:	25 ft. 12/3 cord available in 120 & 240V 50/60 cycle
Weight:	46 lbs. (20kg)
Dimensions:	23" L x 22" H x 10" W

BODY ASSY

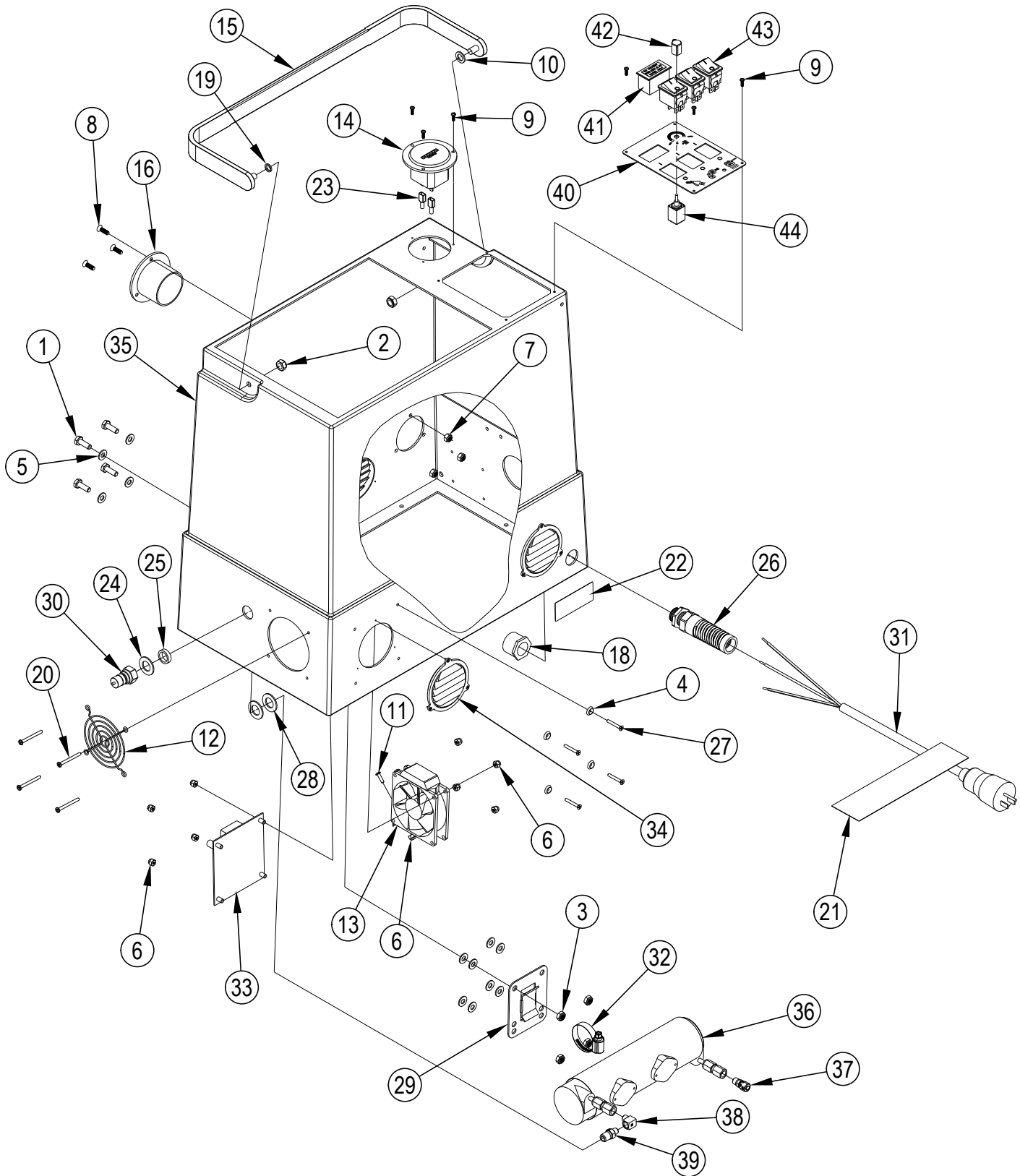

BODY ASSY

Item	Ref. No.	Qty	Description
1	5	4	Bolt Hex 1/4-20 X 3/4 Full
2	7	2	Nut Nylon Lock 5/16 Jam
3	8	4	Nut-Nylock-Zp-1-4-20
4	11	4	Washer Finish 6 S/S
5	14	12	Washer Flat 3/16 Zinc Plat
6	16	9	Nut Nylon Lock 6/32 Z.P.
7	17	3	Nut-Nylon Lock-Ss-10-32
8	22	3	Fhp-10-32 5-8
9	28	3	Screw-Php-Ss-4x3/8-Sms
10	203	1	Washer Nylon White 3/8 Id
11	1152	1	Screw 6-32 X 1/2 Panhead
12	410	1	Guard For 3 Fan Black See
13	412	1	Fan Cooling 120 Volts 3-1/8
14	423-120-240	1	Hour Meter 115/230 Volts With
[]	4332A	1	Label Hour Meter Black Blank (model PB111-120)
15	424	1	Handle Black Aluminum Powderc
16	440	1	Flange Exhaust Black Polypr
[17]	486	1	Wire Black 18 Gauge 500ft R
18	937	1	Reducer Bushing Pvc 3/4
19	1326	1	Washer 5/16 Flat Cut Nylon
20	1496	4	Screw 6-32 X 1 1/2 Pan Head
21	4339	1	Label Caution / Extension Cord
22	56380692	1	Label Danger Electric Shock
23	56469384	2	Recepticle Tab .250
24	115USP	2	Washer 1 Od X 9/16 Id X
25	116A	1	Bushing 3/4 X 9/16
26	184USP	1	Cord Retainer With Flex Prot
27	2A	4	Screw 6/32 X 1 Philips Oval S
28	31USP	1	Washer Brass Half Hard 1 X
29	455USP	1	Mount Heat Exchanger
30	45USP	1	Quick Disconnect Plug Male
31	495A	1	Power Cord 12/3 SjtW25 Ye
32	76A	1	Hose Clamp Ss 1-13/16 X 2-3/4
33	FP247	1	Repair Kit PB111 Heat System
34	SUB459	4	Louver 2-1/2 Grey Plastic W/
35	56384980	1	Base-PB3-Blue
36	FP138	1	Heat Exch. Comp. 120vFOR PB11
37	101	1	Coupling 1/4 T X 1/8 Pipe Br
38	103USP	1	Elbow 90 Deg 1/8 X 1/8 P Brass
39	105USP	1	Reducing Nipple 1/4 X 1/8 Pipe
40	1335	1	Switch Plate Pb3 All Both
41	118A	1	Light Indicator 125 Volts No
42	122	1	Knob Phenolic Black 1/8 Dia
43	FP578	3	Switch Rocker Dpst Illuminat
44	FP200B	1	Potentiometer W/Cable For PB11
			MISCELLANEOUS PARTS
[]	FP144	1	Syphon Plug Ultimate PB3
[]	FP156	1	Vac Exhaust Hose PB3 10ft.+ (all models except PB111-120)
[]	FP665	1	Exhaust Hose 15 PB111 (model PB111-120-SS)
[]	FP247	1	Repair Kit PB111 Heat System
[]	56384926	2	Decal Ultimate PB111 - HM

[] = Not Shown

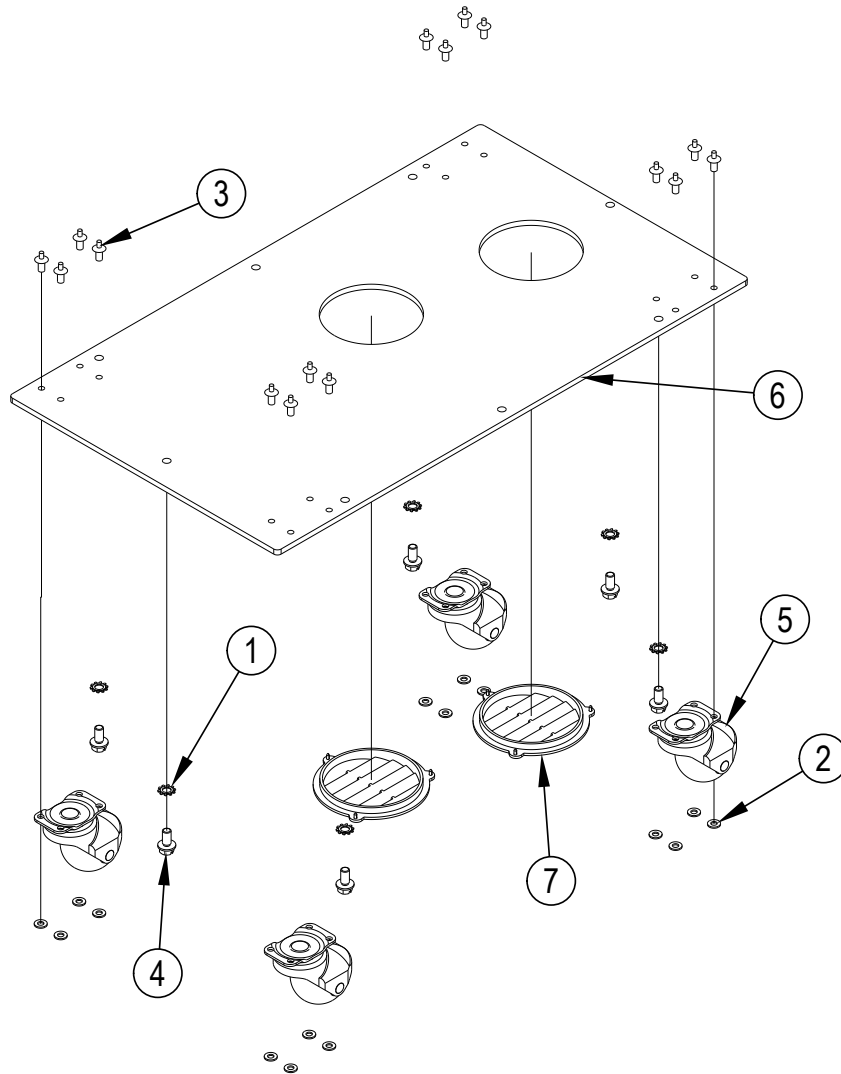

CASTER PLATE ASSY

Item	Ref. No.	Qty	Description
	FP137	1	Caster Plate Complete PB3 &
1	12	6	Washer Lock External Tooth
2		16	Washer-Flat-Al-3-16 NOTE 1
3		16	Rivet, 3/16" Aluminum 1/8" X 3/8" Grip NOTE 1
4	29USP	6	Screw 1/4-20 X 1/2 Hwh SI
5		4	Caster For Ultimate Chrome NOTE 1
6		1	Caster Plate Plastic Polypropi NOTE 1
7	SUB928	2	Louver 3 Grey Plastic Include

NOTE 1: These items are not available for sale separately. Please order FP137 if you need to replace any of these items.

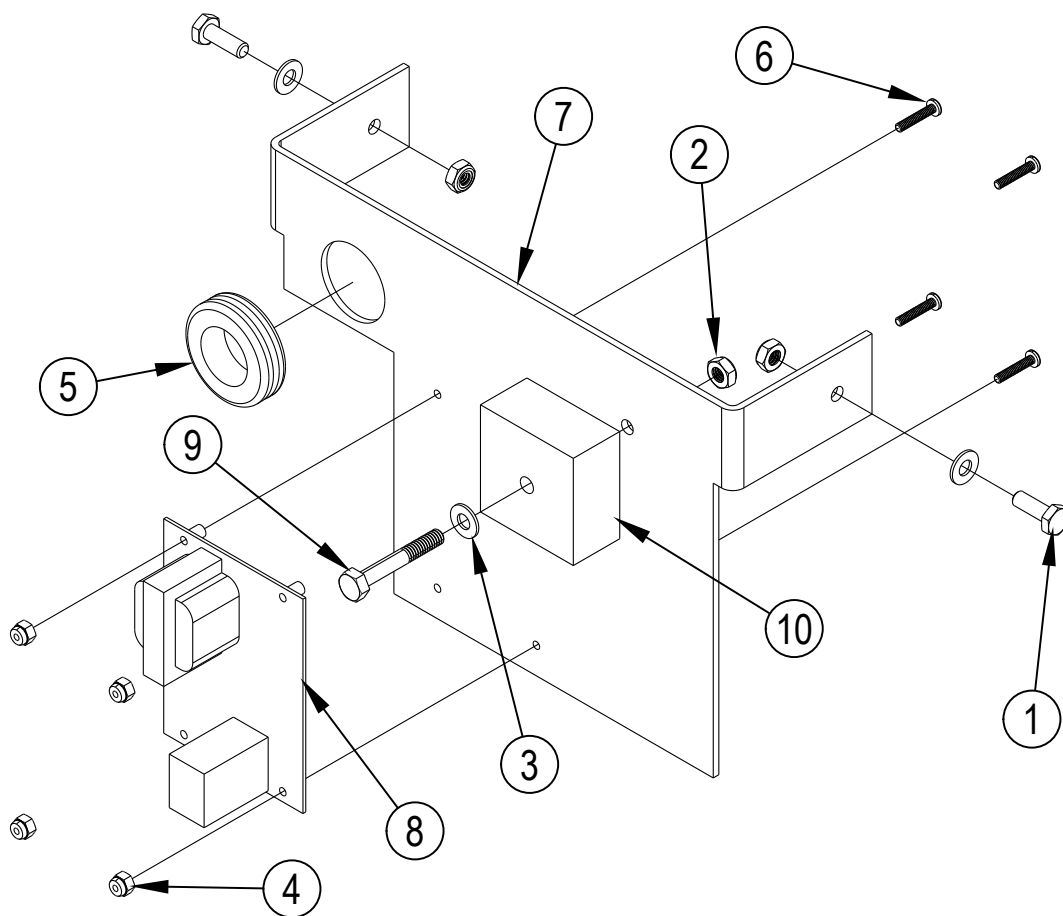

HEAT SINK PLATE ASSY

Item	Ref. No.	Qty	Description
1	5	2	Bolt Hex 1/4-20 X 3/4 Full
2	8	3	Nut-Nylock-Zp-1-4-20
3	14	3	Washer Flat 3/16 Zinc Plat
4	16	4	Nut Nylon Lock 6/32 Z.P.
5	86	1	Grommet 1 Id For A Hole 1
6	151	4	Screw-Php-Ss-Zp-6-32x3/4-Ms
7	429	1	Plate Heat Sink
8	447	1	Circuit Board 120 V Solvent
9	138A	1	Bolt-Hex-Ss-1/4-20x1-3/4
10	409A	1	Relay Solid State 120volt Norm

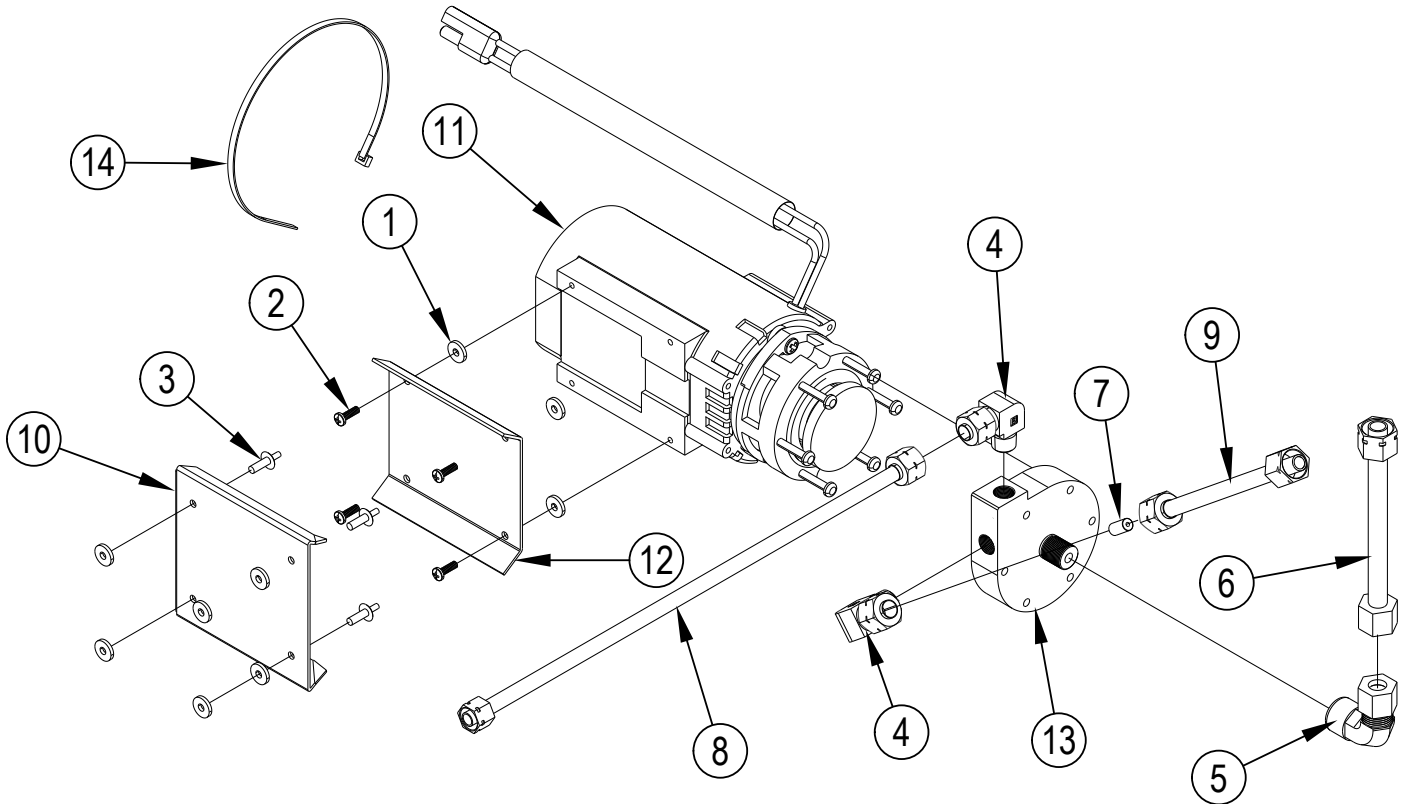

PUMP ASSY

Item	Ref. No.	Qty	Description
1	25	10	Washer-Flat-Al-As-8
2	28	4	Screw-Php-Ss-4x3/8-Sms
3	70	4	Rivet 1/8 Dia. Steel 1/4 To 3
4	100	2	Fitting-Elbw 90-Brass-1/4x1/8
5	104	1	Elbow-Brass-90 °-5-16x1-8fm
6	FP150	1	Tubing Teflon 5/16 O.D. x
7	132	1	Bushing Brass 3/16OD X .062
8	FP149	1	Tubing Teflon 1/4OD X 3/16
9	FP151	1	Tubing Teflon 1/4 OD X 3/16
10	435	1	Bracket Slide Pbiil Pump Fema
11	FP173	1	Pump & Motor PB111 120V No Pu (includes 1, 2, 12)
12	435B	1	Pump Slide Bracket Male
13	SUB405	1	Pump Head Brass For Pb111-120
14	56478523	1	Tie-Cable
*	FP148	1	Pump & Motor PB111 120V With (includes all items shown except 3, 8 & 10)
*	FP197A	1	Pump Head PB111 Complete Wit (includes items 4, 5, 6, 7, 9, 13)

* = Optional, Not Included

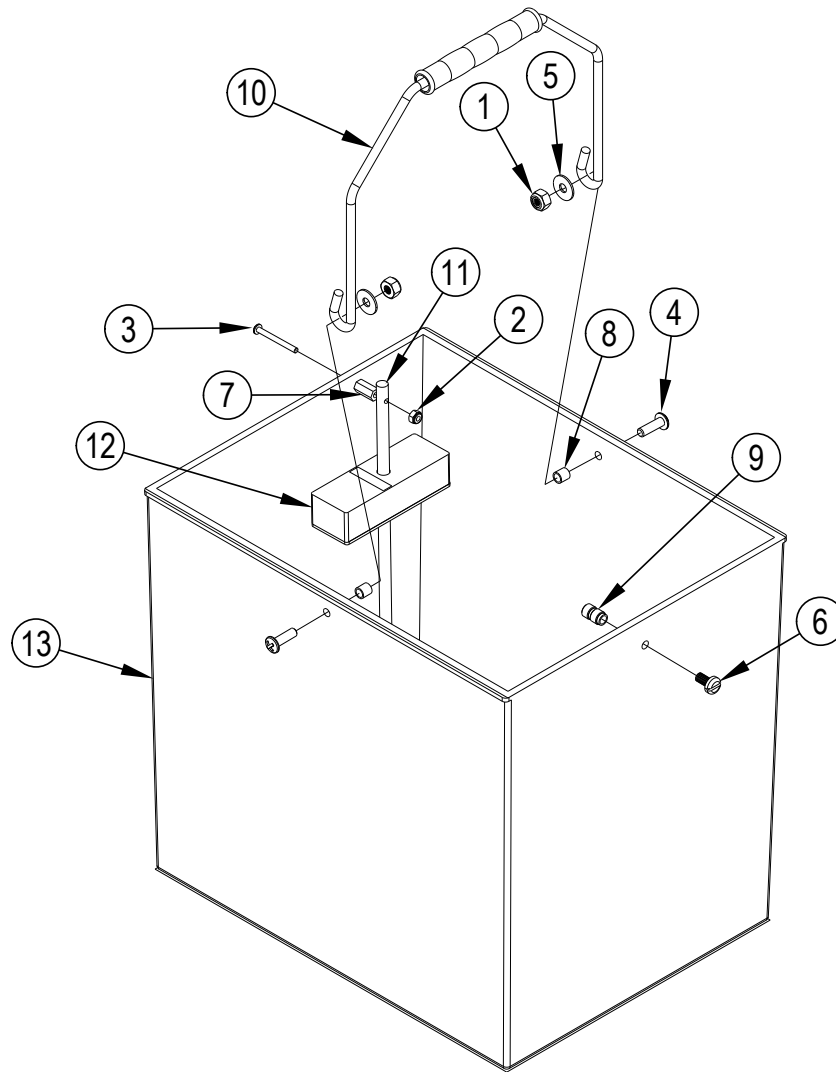

LIFT OUT BUCKET ASSY

Item	Ref. No.	Qty	Description
	FP147	1	Bucket Lift-Out/PB111 Comple
1	17	2	Nut-Nylon Lock-Ss-10-32
2	18	1	Nut-Hex Nyl Loc Ss 4-40
3	20	1	Screw 4-40 X 1-1/8 Ms S/
4	21	2	Screw 10-32 X 5/8 Socket
5	24	2	Washer-Flat-Ss-10
6	33	1	Screw-Bhs-Brass-10-32x3/8-Ms
7	129	1	Bushing Zinc 4-40 X 1/2
8	131	2	Bushing Aluminum 10-32 X 1
9	145	1	Insert .531 X 1/4o.D. X 10/32
10	420	1	Handle-Bucket-Ss-3/16
11	421USP	1	Rod For Float PbiII And XIt
12	FP184	1	Float Assembly No Rod. PBIII
13	FP405	1	Recovery Bucket Only PB111

VACUUM CHAMBER ASSY

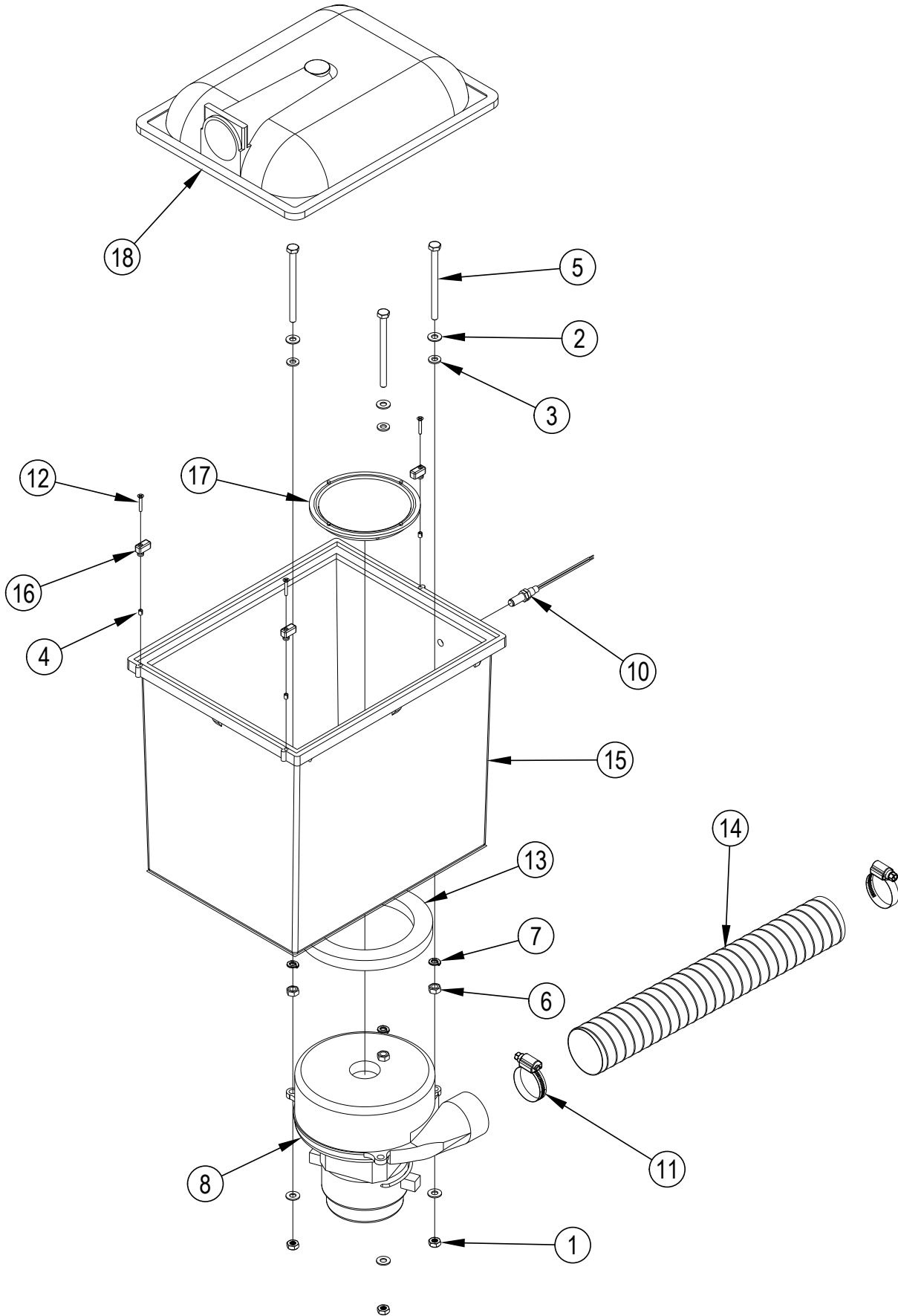

VACUUM CHAMBER ASSY

Item	Ref. No.	Qty	Description
1	8	3	Nut-Nylock-Zp-1-4-20
2	14	6	Washer Flat 3/16 Zinc Plat
3	124	3	Washer Rubber Bunan 90 S
4	130	3	Insert Brass 4-40 X 3/16
5	135	3	Bolt Hex 1/4-20 X 3-1/2
6	136	3	Nut-Ss-Zp-1/4-20
7	137	3	Washer-Slitlock-Ss-Zp-1/4
8	408	1	Vac Motor, 120v
[9]	437	26"	Tape Cloth 2 X 60 Yds Bla
10	123USP	1	Reed Switch 5/16-24 X 1-1/
11	156USP	2	Hose Clamp-Size 28-1-9/16- 2 1/2
12	19USP	3	Screw 4-40 X 3/4 Flathead
13	419USP	1	Gasket-Ccns/Psa-4 Idx1/2 Thick
14	FP163	1	Exhaust Port Hose 2I.D. Vac
15	FP404	1	Vacuum Chamber PB111
16	SUB450	3	Twist Locks Polypropylene Blac
17	FP487	1	Filter Vacuum Inlet PB111 An
18	FP162	1	Dome W/Gasket & Label. PBIII &
[]	439USP	1	Gasket Rubber Bunan Custom R

[] = Not Shown

SOLUTION TANK ASSY

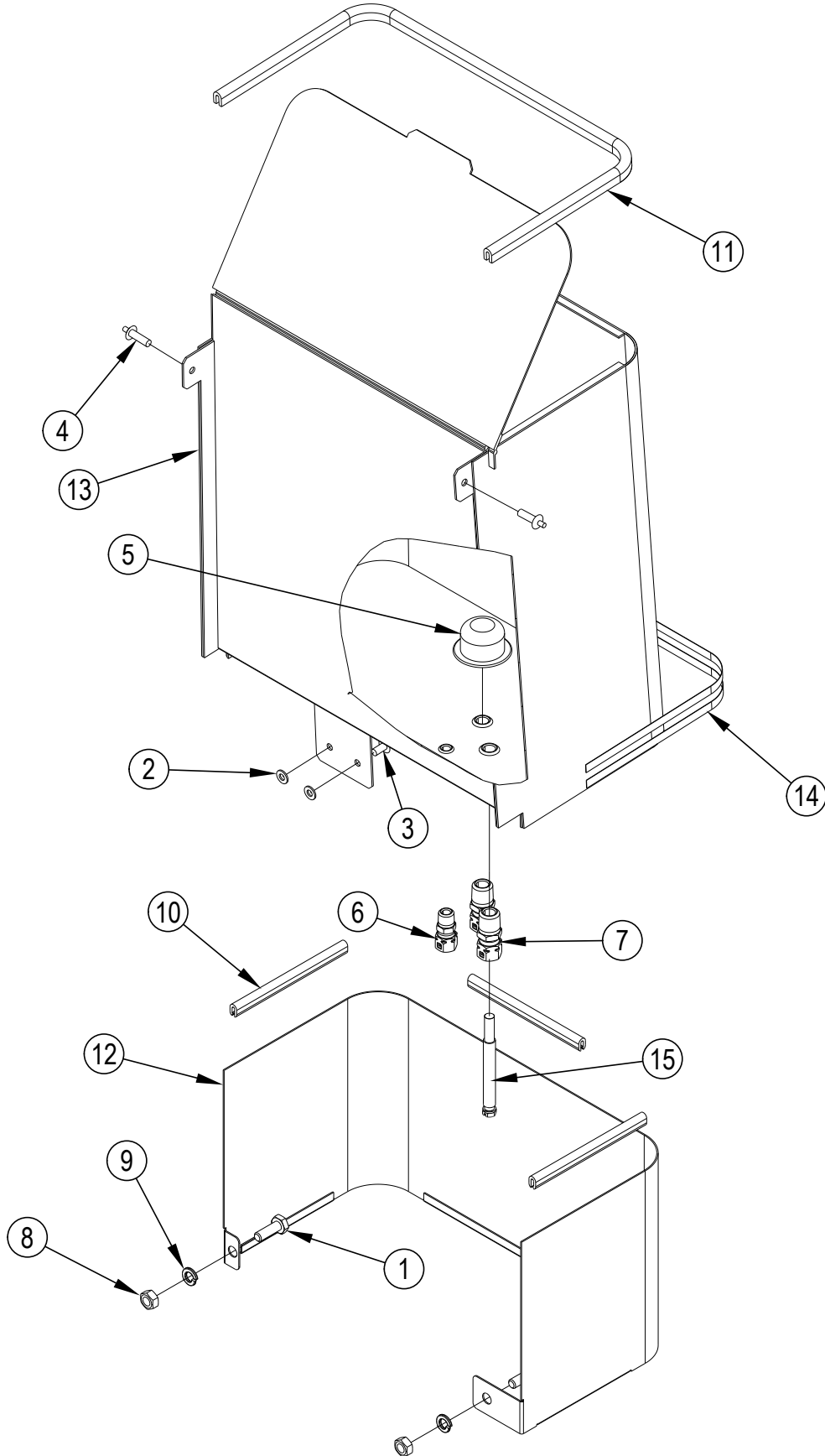

SOLUTION TANK ASSY

Item	Ref. No.	Qty	Description
1	5	2	Bolt Hex 1/4-20 X 3/4 Full
2	26	2	Washer-Flat-Al-3-16
3	72	2	Rivet, 3/16" Aluminum 1/8"X 3/8" Grip
4	73	2	Rivet 3/16dia. Aluminum 3/
5	80	1	Filter 50 Mesh S/S For Filt
6	101	1	Coupling 1/4 T X 1/8 Pipe Br
7	102	2	Coupling 5/16 T X 1/4 P Brass
8	136	2	Nut-Ss-Zp-1/4-20
9	137	2	Washer-Slittlock-Ss-Zp-1/4
10	425	11.5"	Gasket 40 Shore - Santoprene
11	425	21"	Gasket 40 Shore - Santoprene
12	426	1	Cover Pump
13	FP246	1	Solution Tank S/S For PB111 Co
14	454	42"	Pin Stripe Black 1/4 Solid 15
15	FP143	1	Solvent Sense Probe PB3
[]	4321B	1	Label Caution Solvent 2X 3
[]	4324	1	Label Patent 4803466 2X 1

[] = Not Shown

THE ULTIMATE: MODEL PBIII 120V INFORMATION & OPERATING INSTRUCTIONS

DO NOT OPERATE MACHINE UNTIL YOU HAVE READ THIS SECTION IMPROPER USE OF THE ULTIMATE WILL VOID THE WARRANTY

1. Use only extension cord size #12/3, no longer than 50 feet. Replace ground prong if damaged or broken.
2. Never use the Booster Heater when solvent is in the machine. (See Special Features)
3. Never attempt to heat solvent above 125°F .
4. Always use a non-flammable solvent with a flash point of 140°F or higher.
5. The recovery tank should be emptied each time the holding tank is filled with solution.
6. Always make sure the float travels freely up and down the rod after emptying the recovery bucket.
7. Always vacuum out the stainless steel tank and solution lines when switching from a solvent to a detergent or vice versa. (See Operating Instructions, steps #9 and #10).
8. Always use a drop cloth under the machine during operation.
9. Do not keep solution in the machine after use in freezing conditions (vacuum out solution). Freezing causes loose fittings, burst lines and leaks. The machine should be brought in at night. If the machine is to be stored, run anti-freeze through the pump and lines.
10. Do not run the pump dry.
11. Never operate a machine that is leaking or in need of repair

CAUTION: If foaming occurs, use a defoamer. The Auto Vac Shutoff will not sense foam. The warranty is void if damage occurs due to foam overflow. (See Special Features). If there are any questions, before operating the machine, call HydraMaster toll-free 1-800-426-1301. Training tapes and chemicals are available.

INSPECTION:

Carefully unpack and inspect The Ultimate PBIII for shipping damage. Each unit is tested and inspected before shipment. Any damage incurred during shipping is the responsibility of the carrier, who should be notified immediately.

CLEANING SOLUTIONS:

The Ultimate is capable of either wet or dry cleaning. Only liquid cleaners are recommended (no powders). Solvents with a flash point of 140° F or higher are required for safety. Solvents are normally used full strength. Water-based cleaners are normally diluted. Follow label directions.

MAINTENANCE:

Clean the float rod each time the recovery bucket is emptied. Inspect the filters on a regular basis and clean when dirty. The vacuum filter is located under the recovery bucket. The solution filter is located at the bottom of the stainless steel holding tank. (Remove by unscrewing counterclockwise). The quick-disconnects and castors can be lubricated with a WD-40 type product or a silicone-based lubricant. WD-40 can also be used as a stainless steel polish for the holding tank. Armor-All® works well on the body and dome. Number 00 steel wool will keep the brass quick-disconnects shining. For optimum performance, flush the machine with clear water at the end of each working day. Once a month, minimum, run a flushing compound through the machine to cut any alkaline build-up that may have formed. "X-1500 Flush" is recommended for this purpose.

SAFETY PRECAUTIONS:

We recommend the use of a respirator and gloves when using dry cleaning solvents. In addition, a fan or blower is beneficial to blow fumes away from the operator. Always try to work in a well-ventilated area. Always work with the exhaust hose attached to the equipment when using solvents.

OPERATING INSTRUCTIONS



FIG. A

STEP #1

Make sure the recovery bucket under the dome is in the correct position. If the dome will not seat properly, lift out the bucket and rotate it 180°. The bucket must seat level.

STEP #2

Fill the stainless steel holding tank with cleaning solution to the desired level. Solution must be at least 3" above the stainless steel filter.

NOTE: Attach the exhaust hose when dry cleaning (Fig. B).

STEP #3

Position the cleaning tool over the holding tank. Depress the trigger and turn the pump on (center switch). When solution starts to spray, release the trigger. (See Fig. A).

STEP #4

SOLVENT HEATING: Turn on heater switch only. Wait 2 minutes and reposition tool over holding tank (Fig. A). Spray for 15 seconds to preheat lines and tool. NOTE: Heat will shut off completely if the Booster Heater is turned on when solvent is in the tank. Go directly to step #5.

WATER HEATING ONLY: Turn on heater switch and rotate booster switch to desired temperature. Wait 3 minutes and reposition tool over holding tank (Fig. A). Spray for 15 seconds to preheat lines and tool. Wait 30 seconds and then spray again for 15 seconds. Go directly to step #5.

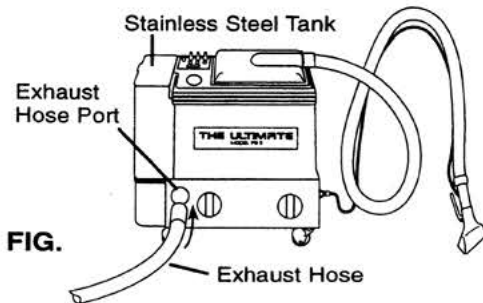

FIG. B

STEP #5

Turn on the vacuum switch. All switches should be on now. You are now ready to begin cleaning (Fig. B).

STEP #6

When the recovery bucket is full, the vacuum will automatically shut off. Lift out the bucket (Fig. C) and empty it by placing one hand in the depression on the bottom of the bucket and the other hand on the handle (Fig. D).

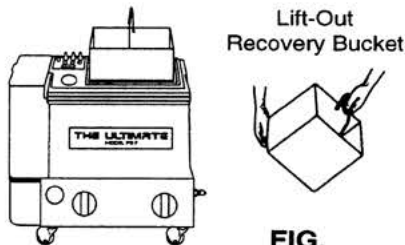

FIG. C

FIG. D

STEP #7

Wipe out excess liquid in the bucket housing area before replacing the recovery bucket. Make sure the bucket seats level.

STEP #8

Make sure the float in the recovery bucket travels up the rod freely each time the bucket is emptied.

STEP #9

When switching from a solvent-based product to a waterbased detergent or from a detergent to a solvent, use the following procedure: Turn off all switches except the vacuum motor switch. Insert the vacuum hose into the holding tank and vacuum out the solution. Then place the end of the hose over the filter screen for 10 seconds. (See Fig. E). Go directly to step #10.

STEP #10

Attach the black suction plug to the solution line. Remove the vacuum hose from the vacuum port and gently push the suction plug into the vacuum port (Fig. F). Turn on the vacuum only, allowing 20 to 30 seconds for the line and internal components to be vacuumed clean.

NOTE: DO NOT LET PUMP RUN DRY!

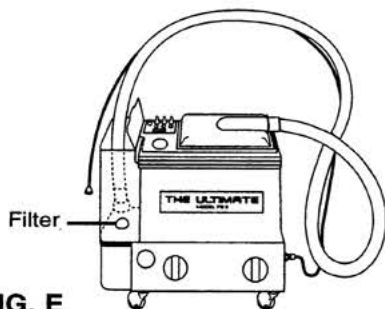

FIG. E

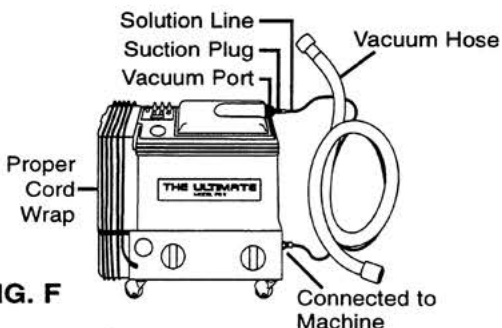
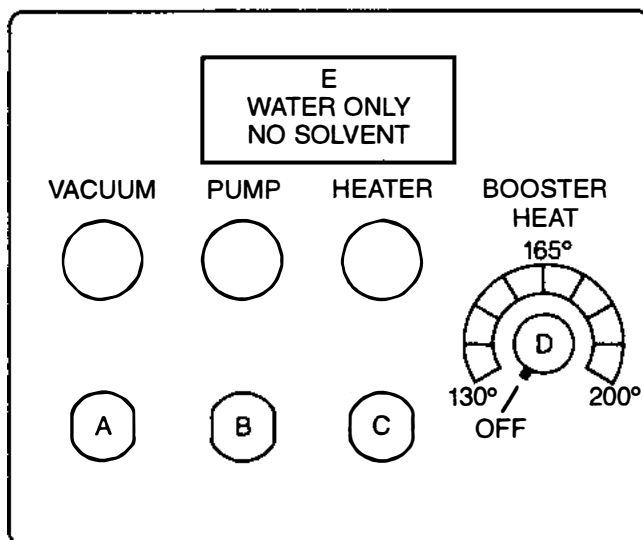

FIG. F

SWITCH PLATE WITH BOOSTER HEATER



A= Vacuum Switch
 B= Pump Switch
 C= Heater Switch
 D= Booster Heater
 E= Warning Indicator

SOLVENT HEATING: Turn on HEATER SWITCH (C) **only**. BOOSTER HEATER (D) must be **off** (all the way counterclockwise) or machine will not heat at all.

WATER HEATING: Turn on HEATER SWITCH (C) and BOOSTER HEATER (D) to desired temperature, 130°-200° F.
NOTE: BOOSTER HEATER will not work unless HEATER SWITCH (C) is on.

**WATER ONLY,
 NO SOLVENT (E):** This indicator light illuminates when BOOSTER HEATER (D) is on. It is a reminder that the booster heater will only heat water-based solutions.

CAUTION: USE A RAG TO DISCONNECT BRASS FITTINGS AFTER USING BOOSTER HEATER. FITTINGS ARE VERY HOT AND MAY CAUSE MINOR BURNS.

SPECIAL FEATURES

AUTO VAC SHUTOFF: When the recovery bucket is full, the vacuum motor will automatically shut off. This system will not sense foam. Defoamer must be used to avoid vacuum motor damage.

WATER HEATING: This unique patented system determines whether there is solvent or water-based solution in the tank. If solvent-based solution is in the tank, it will automatically prevent heating above 125° F. If operator attempts to use the booster heater with solvent, the entire heating system will shut down until the booster heater is turned off. This eliminates operator error.

THE ULTIMATE WIRING DIAGRAM

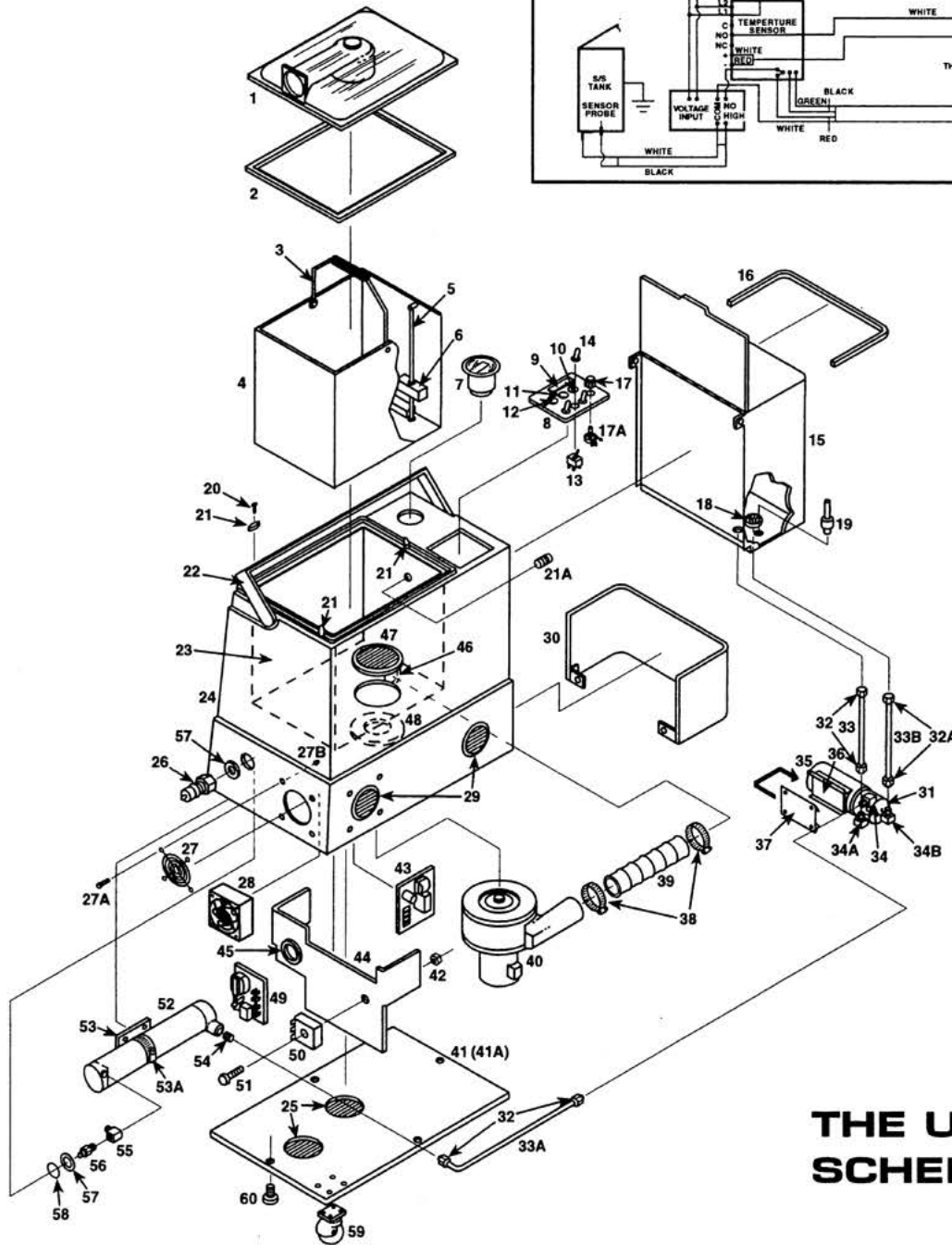
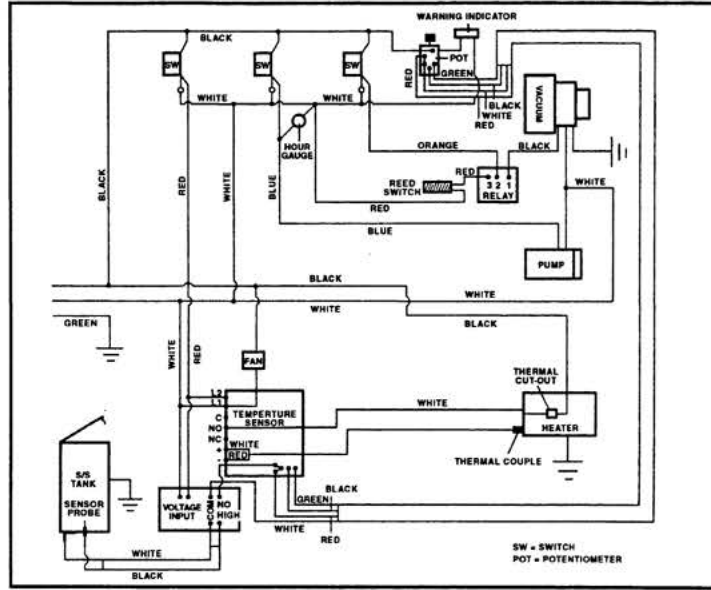

THE ULTIMATE SCHEMATIC

PBIII PUMP EXPLODED VIEW

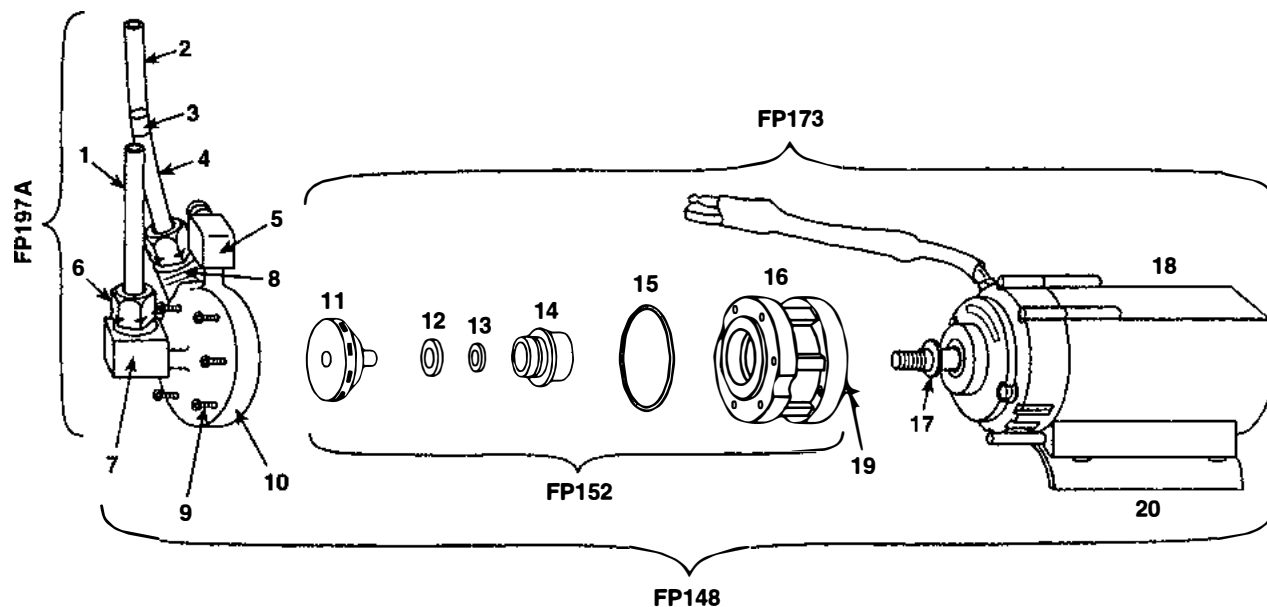

NO	PART NO	DESCRIPTION
1-10	FP197A	Pump Head Complete (Brass)
1-20	FP148	Pump Complete
11-16	FP152	Pump Rebuild Kit
11-20	FP173	Pump and Motor
1	FP150	5/16" Tube w/ Fittings
2	FP151	1/4" Tube w/Fittings
3	132	Brass Restrictor
4	107	Compression Nut and Sleeve, 1/4"
5	99	Brass elbow, 90 Degrees, 1/4" Pipe
6	106	Compression Nut and Sleeve, 5/16"
7	104	Brass elbow, 90 Degrees, 5/16" Pipe
8	100	Brass elbow, 90 Degrees, 1/4" Pipe
9	406G	Screw
10	405	Pump Head (Brass)
11		Pump Impeller
12 & 13		Viton Seat with Ceramic Seal
14		Pump Carbon
15	406C	Pump O-Ring
16		Pump Adapter
17		Motor Slinger Ring
18	406J	Motor (120 Volt)
19		Screw
20	406H	Pump Slide Bracket (Male)
	435B	

TAKING THE MYSTERY OUT OF UPHOLSTERY & DRAPERY CLEANING

TAKING THE MYSTERY OUT OF UPHOLSTERY AND DRAPERY CLEANING

As the title implies, you are about to learn how relatively easy it is to clean upholstery and draperies. Covered in this manual, are potential problem areas and their remedies plus some useful facts about fabrics. (You will be relieved to know that identifying the actual fabric to be cleaned, is not as critical as you might believe). Some fabrics are easy to identify, such as silks, satins, velvets, jacquards, etc.

FABRIC CATEGORIES:

There are two categories of fabrics; natural and synthetic. Natural fabrics are made from fibers found in nature. These fibers are derived from either animal or vegetable sources. Synthetic fibers are man-made.

*Rayon is unique because the fibers are natural, but the process is man-made. For cleaning purposes, it has been categorized as a natural fiber.

There are only two types of fiber construction, staple and filament. Staple fibers are those of a specific length, such as wool or cotton. These range in length from 1" to 12". Filament fibers are long and continuous with no specific length. (The silkworm can produce fibers as long as 4 miles.) All synthetics are made from filament fibers and are manufactured to varied lengths. If the filament fibers are cut into shorter lengths, they become staple fibers.

It is interesting to note that while carpets are being manufactured with more synthetics today (which makes them more durable and easier to clean), in most cases, upholstery is still made with natural fibers. Natural fibers are softer, breathe easier and are more comfortable. Synthetics are manufactured as Filament Fibers. Sometimes synthetic and natural fibers are mixed together in an effort to create a better fabric. Manufacturers have become so creative that by varying the thickness of a synthetic fiber, along with the proper amount of crimping or combing, a synthetic fiber like nylon, can be made to feel and look like wool or other natural fabrics; this is one reason fabrics can be difficult to identify.

Fabrics can be woven and tufted or woven only. When a woven fabric has a third set of fibers brought up through the weave, it is transformed into velvet. Velvet is not a particular fabric, it is a weave and can be made of natural or synthetic fibers. There will be more information on velvets further on.

There are Two Categories of Fabrics:

SYNTHETIC FIBERS



Man-made

- Nylon
- Orlon
- Acrylic
- Polyester (Dacron)
- Polypropylene (Olefin, Herculon)
- Acetate

NATURAL FIBERS

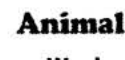

Animal

- Wool
- Silk
- Hair



Vegetable

- Rayon*
- Flax
- Sisal
- Hemp
- Cotton
- Linen

* Rayon is unique because the fibers are natural, but the process is man-made. For cleaning purposes, it has been categorized as a natural fiber.

There are Two Types of Fiber Construction:

STAPLE FIBERS

have a specific length ranging from 1" to 12"

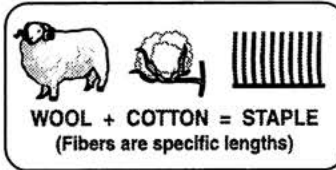

FILAMENT FIBERS

are long and continuous with no specific length

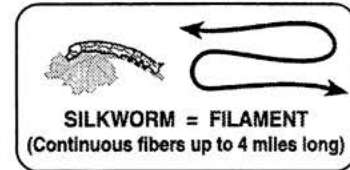

Synthetics are manufactured as Filament Fibers.
When cut to shorter lengths they become Staple Fibers

YARNS:

Yarns are woven on a loom to create the fabric desired. The yarns that run lengthwise, or up and down, are called the warp and the cross yarns are called the weft or the filling yarns. To obtain a basket weave, the same procedure is used; the only difference is the yarns are woven in pairs. By varying the yarns, different patterns can be achieved.

Satin, for instance, is a weave not a special fabric as most people believe.

Like velvet,

satin can be made from either a natural or a synthetic fiber. It is possible to set different designs on top of the finished fabric. One popular design is the "moire" (mo-ra): it resembles a wood grain. If the moire pattern is set onto a synthetic fabric, it is permanent. If it is set onto a natural fabric, it is possible to remove the pattern in cleaning. See the testing and identification section for a description on how to test a fabric to determine if it is natural or synthetic. Most moire designs are found on acetate and are permanent. Acetate is a high luster fabric that resembles silk.

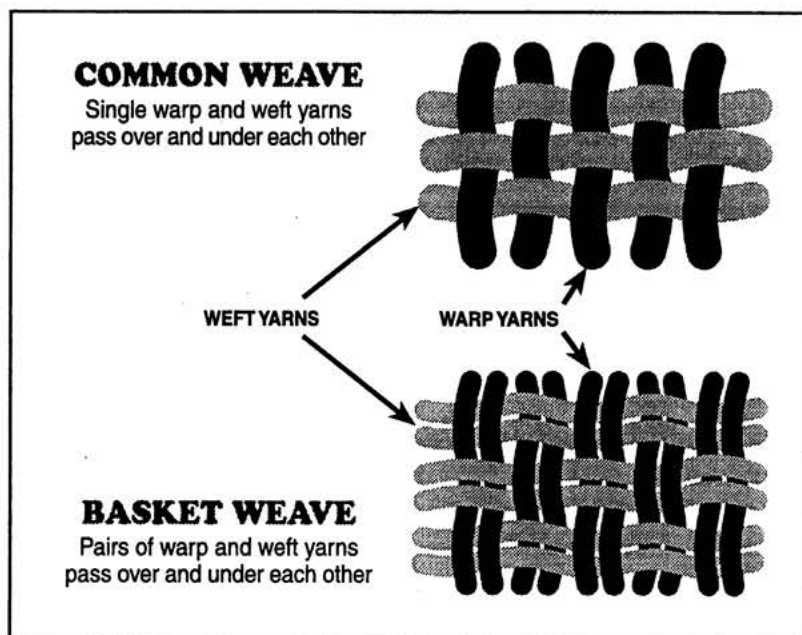

ACETATE:

Acetate s are very bright unless they have been treated to remove the shine. They do not absorb well, causing soils to remain on the surface and therefore are easier to clean. Acids and strong alkalis are detrimental to acetate, and acetone will completely dissolve it. Most fabrics are blends and acetate is no exception. Rarely will you find acetate in its pure state.

HAITIAN COTTON:

Haitian Cotton deserves special attention because it "browns out" so easily and can present a problem to the professional cleaner. Haitian Cotton is not processed like normal cotton. All the debris from its native environment is left in the fabric, such as seeds, twigs and dirt. The seed is yellow brown in color and when over wet, will bleed to the surface and cause "brown out." The correct procedure for cleaning Haitian Cotton and preventing "brown out" will be covered later.

RAYON:

Rayon is made from the dissolved pulp of the mulberry tree. Although the fiber is natural, the process is man-made and therefore, can cause some confusion as to which category it belongs. For cleaning purposes, rayon should be categorized as a natural fabric. Rayon is inherently weak and is manufactured with a blend of cotton for additional strength.

SILK:

Silk is said to be the fiber of royalty. The Chinese are given credit for developing silk fabric and are still, to this day, large producers of silk. Silk is a fine, soft, lustrous fiber obtained from the cocoon of the silkworm. When it is woven, it produces one of the strongest of all natural fabrics. It cleans well and since it does not stretch or shrink, is a very desirable fabric. Silk, however, does not hold up well to sunlight and therefore, is not suitable for drapery.

NYLON:

Nylon, polyester and polypropylene, also known as Olefin or Herculon, are among the first true man-made fibers that are widely used in the U.S.A. today. Fabrics made from these fibers clean well, are very durable, and have a long life expectancy. All fabrics will "pill" slightly when they are rubbed or abraded. The loose ends of most fabrics will break off or form lint. Synthetic fabrics are so strong, they form balls on the surface that do not abrade away and are somewhat unsightly; this condition indicates it is a synthetic fabric. Additional information on fabrics can be obtained from HydraMaster at 800-426-1301.

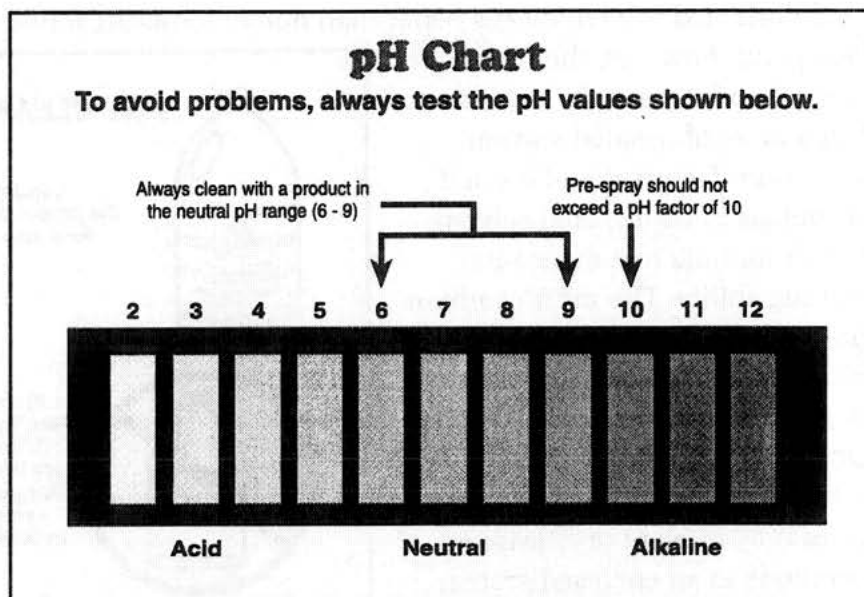

CHEMICALS AND PH:

To avoid problems, certain basic information is necessary in order to determine the correct chemical to use when cleaning different fabrics. First, be aware of the pH factor of the chemical being used. This will enable you to determine whether the product is safe, too alkaline, or too acid. To avoid problems, always clean with a product in the neutral pH range (between 6 and 9). A pre-spray solution, with a pH of no more than 10, should be used for heavily soiled areas. A pH reading is also valuable when testing a soiled spot of unknown origin. If the pH of a spot tests 5, 2 points below 7 (7 is neutral), use a spotter 2 points above 7 (a product with a pH of 9).

This neutralizes a spot making it easier to remove. Browning of a fabric, especially a white or light fabric, occurs if it is cleaned with a high pH product. Fabrics can also turn brown from over wetting, followed by an extended drying time. Usually an acetic acid product, or tannin acid product, will remove browning. These products can be purchased from a HydraMaster distributor.

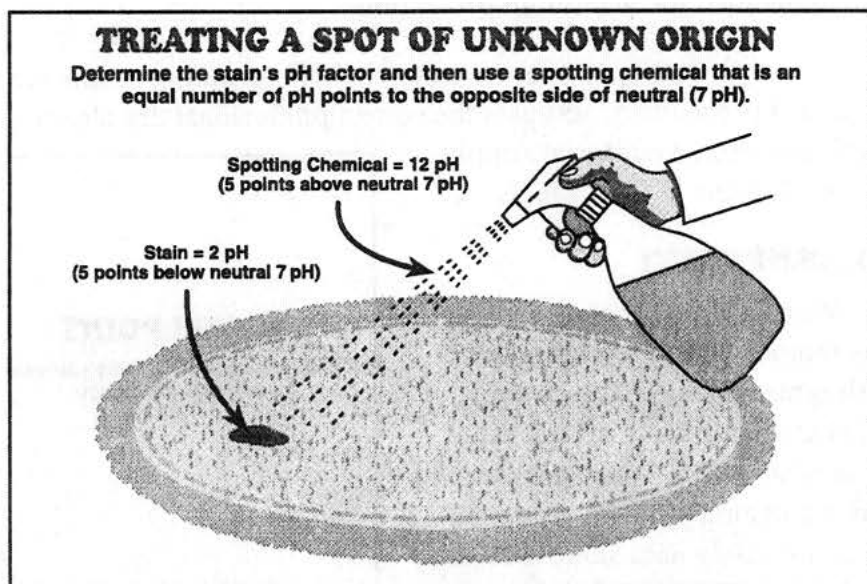

SOLVENTS AND DETERGENTS:

The dry cleaning solution we recommend is Formula 801, which is a ready to use solution. This product is available from your local HydraMaster distributor.



FLASHPOINT:

What is a flashpoint? This is the temperature at which a solvent will ignite or flash. The cleaning solvent should have a flash point of at least 135° F. When purchasing a dry cleaning product, request a material safety data sheet (SDS); by law your supplier must provide you with this information. The SDS sheet will list the contents, hazards and the flash point of the product being purchased.

HEAT:

To “dramatically” increase the results when wet cleaning, heat the solution to at least 200° F. Wet cleaning with 200° F versus 100° F, will increase cleaning efficiency 3000%! The fabric will not be harmed, as it receives the heat for only a few seconds. At this temperature, dyes normally will not run, as heat actually sets the dye, however in some cases the heat may cause the dye to run, if the fabric retains the heat for a period of time (See bleed test on next page). The heated water will evaporate off the surface faster and will speed up the drying time with less chance of shrinkage.

When dry cleaning, in order to maintain an adequate safety margin, never heat the solvents above 125° F. Although it is rare for dry cleaning fabrics to bleed, it can happen, so do check for bleeding; it is not necessary if the fabric is all one color (See bleed test on next page.)

TO WET CLEAN OR DRY CLEAN:

Before cleaning any furniture, the first question to ask is: “Should I wet clean or dry clean the fabric?” Always wet clean when you can, as the result are usually better than with dry cleaning. Dry cleaning, however, is a must on some fabrics and is invaluable when cleaning bleeders (a fabric in which the dye runs). It is generally agreed that jacquards, silks, velvets, brocades and bleeders are best dry cleaned.

FLASH POINT
The temperature at which solvent will ignite or flash.

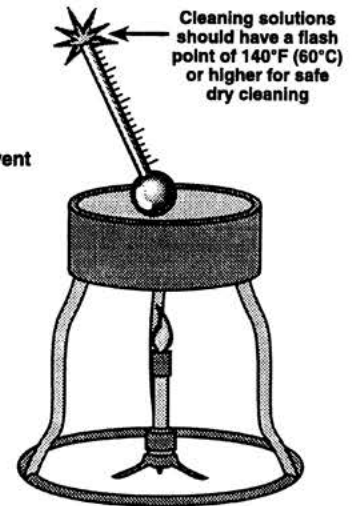

THE ANATOMY OF A SOFA

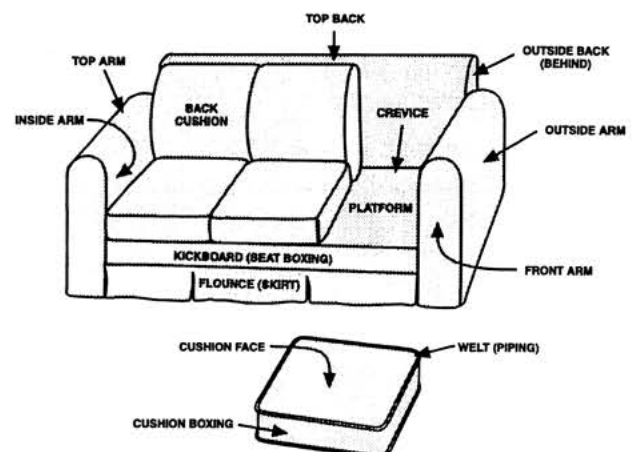

SHRINKAGE TEST:

Although many professional cleaners do not perform the shrinkage test, to prevent problems, this test should be done on all natural fabrics (synthetics will not shrink).

1. Create a 2 1/2" x 2 1/2" square with straight pins.
2. Using a salt and shampoo mixture of 1 oz. table salt to 2 oz. shampoo (salt prevents bleeding), saturate the fabric within the 2 1/2" square outlines by the pins. Work the solution into the fabric if necessary. If the solution beads up, it indicates the fabric has been treated with a soil and stain retardant.
3. Wait 15 minutes (20 if the solution beads up).
4. Measure between the pins in both directions (weft and warp) making sure they are still 2 1/2" apart. Note any change in the measurement and dry clean the fabric if shrinkage is excessive.

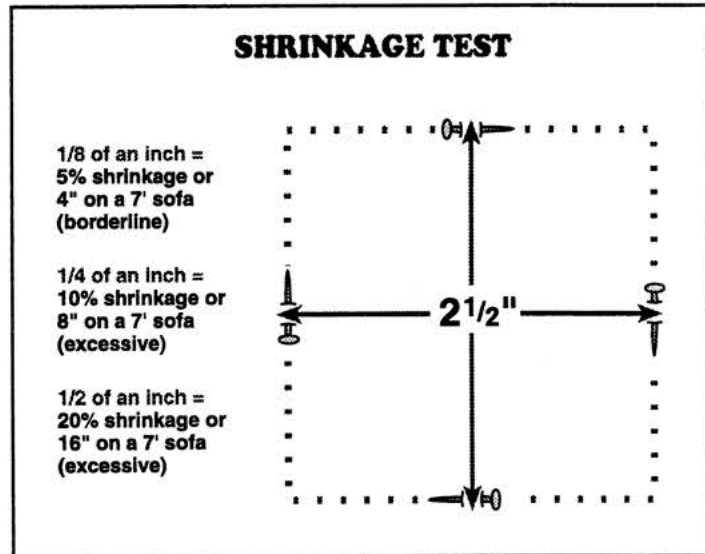

BLEEDING TEST:

To help determine the best way to clean upholstery, there are three important questions to keep in mind: (1) "Is it a bleeder?" (2) "Is the fabric stable?" (3) "Will there be any surprises?" The first test is to determine if the fabric is a bleeder. Many professional cleaners perform this test by rubbing a white cloth (wet with cleaning solution) across the surface; this is actually an inaccurate test. Experiencing some color transfer (color cooking), does not mean that the fabric is a true bleeder, it simply means excess dye is being wiped off. Approximately 30% of all fabrics will crock and less than 5% of the fabrics are bleeders.

To test for a bleeder, unzip the side of the cushion. The inside and the outside of the fabric are both tested in this procedure. Use a pre-spray product with a pH of no more than 10. The pre-spray should be in a small test bottle with an applicator cap. Work an area approximately the size of a quarter, on both the inside and outside of the material. The solution is worked into the fabric vigorously in order to penetrate through any protective coating (like Scotch Guard), otherwise the test may be distorted.

Each color must be tested. (Example: 5 colors = 5 tests) It takes approximately 20 minutes for the test to dry. If the fabric is a bleeder, the migration or bleeding of the color will take place within the last few minutes of the test. Do not use a hair dryer to speed-up the test. The "fast drying" of the test could prevent a bleeder from bleeding. If it is an expensive piece of furniture, and you are concerned, ask the customer for permission to take the cushion back to your place of business for further testing. You can then aggressively clean the zipper side of the cushion, allowing it to dry thoroughly and then observe the results.

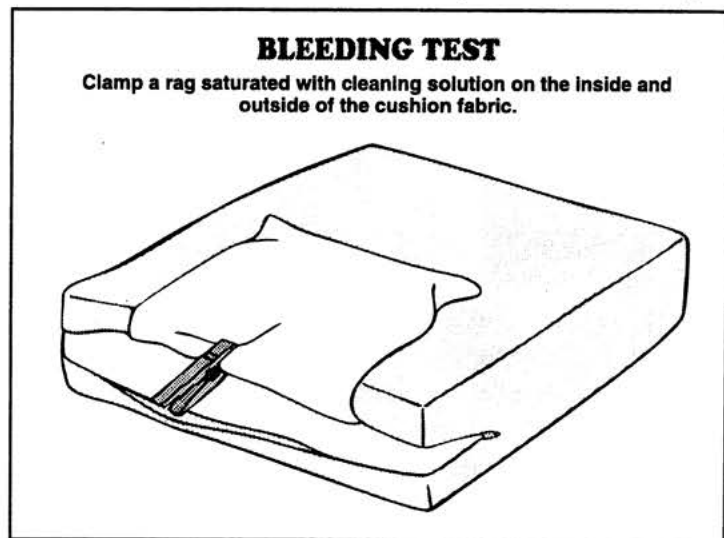

Check inside the cushion for any magic marker lines or numbers. Sometimes the manufacturer will mark the foam or the fabric for I.D. purposes. To prevent the marks on the foam from bleeding through, place plastic between the foam and the fabric.

Let the customer know the plastic should not be removed before the fabric dries. If there are any marks on the inside of the fabric itself, they will most likely bleed through during the cleaning process. Inform your customer there is a risk of discoloring the fabric of this particular piece of furniture; let the customer make the final decision. These marks normally do not appear on the arms or back of the furniture as the foam is not usually used in these areas. In most cases, these areas are filled with cotton or Spanish Moss padding.

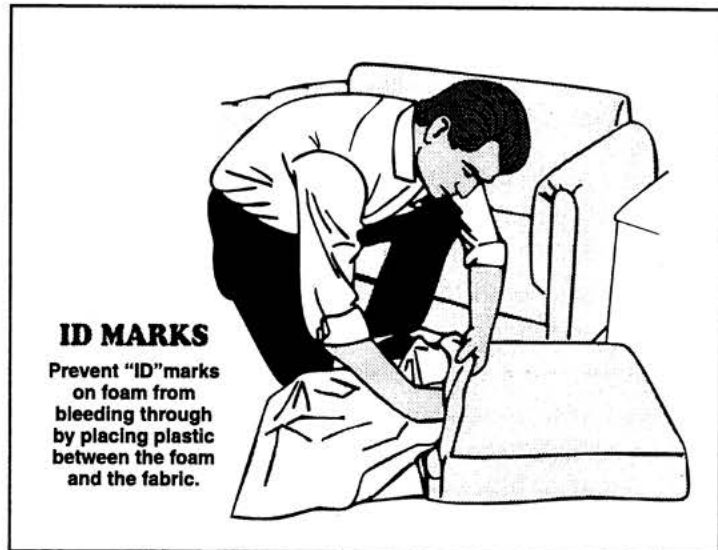

It is rare for a manufacturer to sew a cushion together with a thread that will bleed, but since the cushion is open, check for colored threads that could cause a problem. As you inspect the inside of the inside of the cushion, notice whether it is dried out or possibly crumbling. If it has deteriorated, the powdery foam could be pulling through the surface during the cleaning process. In this instance, encase the foam in a plastic bag before cleaning. (Chlorinated solvents will dissolve latex, and the foam; non-chlorinated solvents or water-based products are safe.) If you notice this condition, bring it to the customer's attention and note it on the inspection form.

FABRIC STABILITY TEST:

The fabric stability test is performed in many areas where the fabric has heavy usage, such as head and arm rests, cushions, and faded soiled areas. Using the pointed side of a bone scraper, make a gentle stroke on the fabric to try and separate the yarns in both directions. (Note: If the yarn break or tend to separate easily, in order to clean safely, simply place a 12" x 18" fiberglass screen (available in any hardware store) over the area and proceed to clean through the screen. The screen will hold the fabric in place and prevent any damage from occurring). Next, check the skirts, flounces, welting (beading) and zipper areas to see if they are torn or pulled away from the body of the furniture. Look for cigarette burn holes. Have the customer sign a simple statement acknowledging any of the conditions that have been noted, or if you are concerned about asking for a signature, at least point out the existing conditions and give her copy.

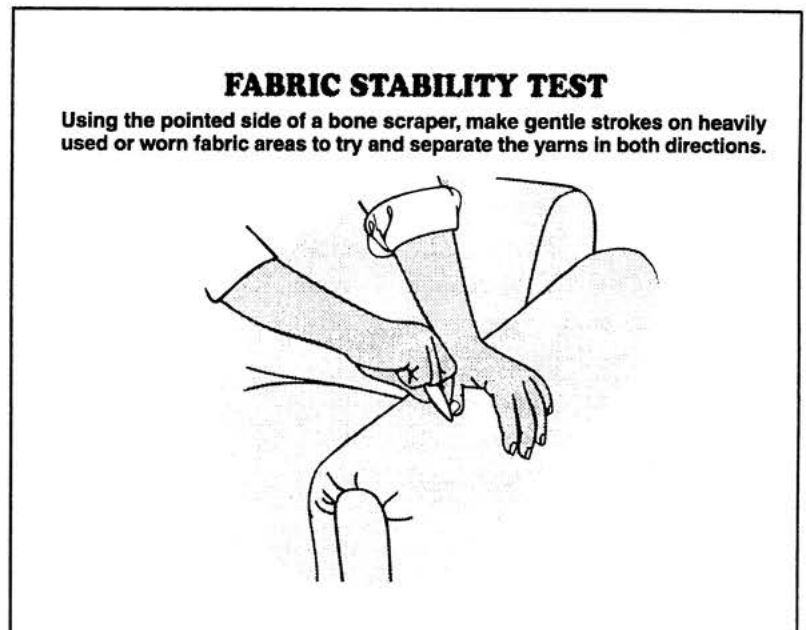

HAITIAN COTTON IDENTIFICATION:

Although there is no accurate test for Haitian Cotton, it can be identified by its uneven bumpy texture. Some of the weaves are tight, some are loose and some have latex backing, while others do not. The most efficient way to identify Haitian Cotton is to view it through a magnifying glass with a light attachment. You will notice pieces of seed, husk, and probably other debris, as this cotton is not processed.

This fabric is so popular that manufactures are now making synthetic Haitian Cotton. This synthetic fabric cleans out well and does not "brown out". If there is any doubt about the identity of the fabric, do a burn test. Cut off a piece of excess material, place it in an ash tray and light it. If it is a natural fabric, it will burn and leave a soft ash. If it is a synthetic fabric, it will melt rather than burn and leave a hard black bead. There are special cleaning procedures for natural Haitian Cotton, which will be covered later.

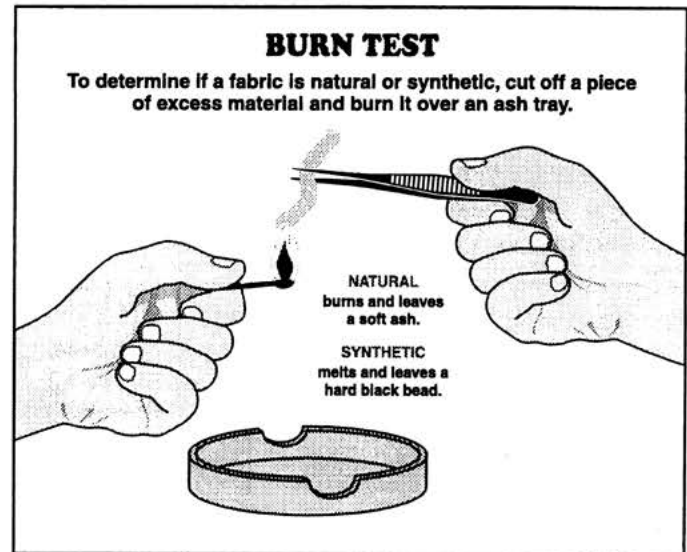

SURPRISES:

Before cleaning any furniture, check for "surprises".

By doing a little detective work and asking the right questions, potential problems can be prevented. Ask the customer these questions: (1) "How old is the furniture?" (2) "Is it a hand-me-down?" (If it is, it could be very old a fragile) (3) "Has it ever been cleaned?" (4) "What caused the spots of stains?" (5) "Has any spotting been done?" People use products like "409" or other advertised brands for spotting. Some of these products have a pH that is too high and can leave the fabric weakened. Most people do not rinse spots, therefore the sticky residue left attracts dirt and re-darkens or seems to cause the spot to reappear. These spots are easily removed, however, the fabric under the spot may be left bleached or weakened. Alert the customer to this possibility.

Check with the customer ahead of time to determine if there is any special attention, such as an odor problem. The customer may be expecting you to remove an odor that cannot always be detected or he/she may be under the assumption that you are going to remove the source of allergy problem by cleaning the furniture.

You cannot guarantee to solve these or even guarantee the removal of all spots and stains. You can only guarantee that you will use professional procedures, professional chemicals and if the spot can be removed, you will remove it.

Sometimes the only reason the customer wants the furniture cleaned, is to remove the little balls of unsightly fabric (referred to as pilling) that have formed on the traffic areas. Inform the customer that these fabric balls cannot be cleaned away. They can, however, be removed with either a pair of sharp scissors, a barber's hair clippers or a "pill" remover (used for sweaters). This last item resembles an electrical shaver and works well for removing lint balls on upholstery. (Charge extra for this service).

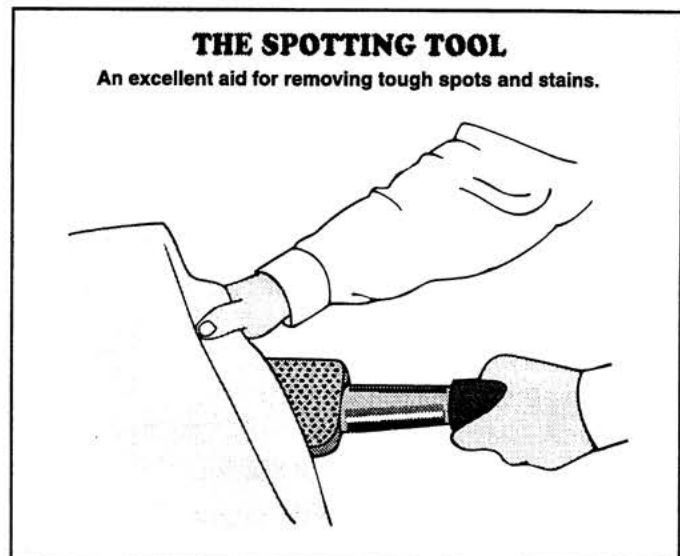

EQUIPMENT:

Before discussing cleaning procedures, there are some important guidelines to consider before purchasing your cleaning equipment. The upholstery and drapery cleaning machine should have the following features:

1. 35-50 PSI pump pressure
2. #1 or #2 upholstery tool spray tip
3. 80" +vac lift
4. Build-in heat source
5. Wet and dry cleaning capability
6. Automatic vacuum safety shutoff
7. Automatic solvent sensor safety shutoff



We recommend HydraMasters' "THE ULTIMATIVE MODEL PBIII" for upholstery and drapery cleaning for all fabrics surfaces. This machine has unique features not available on other equipment. At 46lbs., the PBIII is lightweight, compact, portable and very easy to handle. The unit can be stored behind the front seat of an automobile.

The body is made of a molecular polyester resin material that cannot crack, break or leak and has a lifetime warranty. The stainless steel holding tank has a 3½ gallon capacity. The 3½ gallon lift-out recovery bucket speeds the disposal and cleaning process. All control switches and indicator lights are located on top for easy access.

The entire machine was designed with ease of service mind; for instance, the pump which has sealed bearings, never needs lubrication and rarely requires service. If any service is necessary, however, simply back-off the two thumb screws to remove the pump cover, and slide the pump off the slide mount. There are no nuts or bolts to remove and the electrical wires are push-pull connected.

The built-in heat exchanger is another exclusive feature. Most equipment on the market today heats the cleaning solution with an immersion heater. This type of heater actually sits in the holding tank and comes in contact with the solution. (Because of the extreme hazard of heating solvents in this manner, the immersion system should not be used). Each time the holding tank is filled, the immersion type heater takes approximately 25 minutes to heat to the correct temperature for cleaning. This is eliminated with the HydraMasters' heat exchanger system which requires only an initial two minute warm-up. Cold detergents or solvents is poured into the holding tank, the solution then flows through the pump cold (saving the life of the pump), enters the heat exchanger and comes out the tip hot, instantly!

This sealed system is the safest on the market today, as well as the most efficient. The entire system is monitored by a solid state sensor network with a fail-safe back-up safety guard. The heat exchanger is accurate within 1° and has a lifetime expectancy. The 125° F setting is recommended for safety when working with solvents. For wet cleaning, we recommend the maximum setting of 200° F.

The "Upholstery Tool" cleans by spraying solution through the spray tip onto the fabric, followed by immediately by the vacuum stroke.

The "Upholstery Scrub Head" gives an added cleaning advantage. With 0-1200 RPM capability and the use of the "scrub brush", this unique equipment allows for a little extra heavy duty, deep cleaning. If a gentler cleaning action is needed, or if you wish "speed dry" the fabric, use a "drive brush" with a "spin pad". A clean dry pad is placed in the "drive brush", the operator adjusts the speed to suit his/her needs, and the proceeds to gently clean or spin dry the fabric. The heat caused by the friction of the pad helps to shorten the drying time. The "Upholstery Scrub Head" is easy to use and allows for greater efficiency when cleaning areas such as the welting and edges of the furniture.

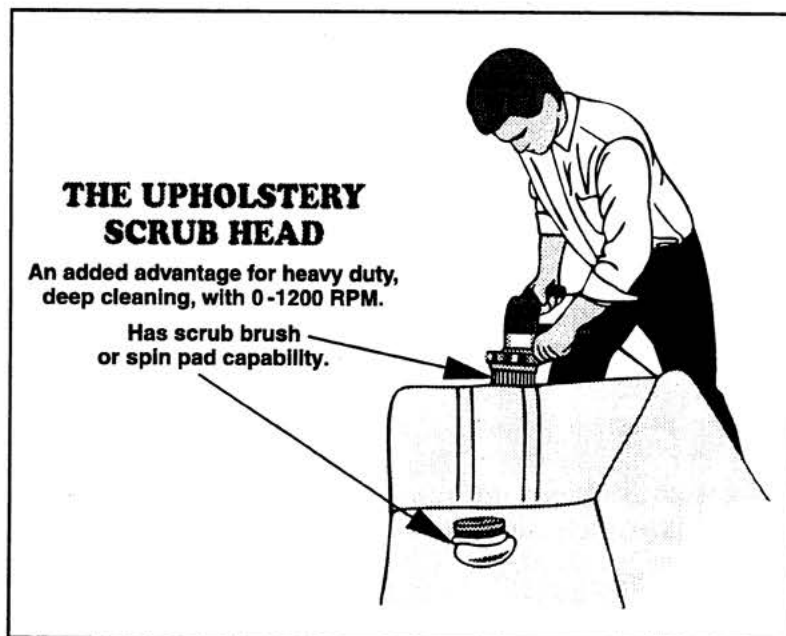

WET CLEANING PROCEDURE:

First, place drop cloths around the furniture to be cleaning. This not only protects the carpet from spills or overspray, but also creates a professional touch. Next place a drop cloth under the equipment to protect against accidental spills when filling and emptying the machine.

VACUUMING: Dry vacuum all upholstery to be cleaned. If there is animal hair to be removed, use a link roller before cleaning (wet hair will not stick to the roller).

PRE-SPRAYING AND BASIC CLEANING PROCEDURES: Mix magic Fabric cleaner (detergent) per instructions and add solution to the holding tank. Pre-spray using the "upholstery tool" (attached to the extractor machine). Wait a 3-5 minutes, then follow up with additional spray and vacuum strokes. Apply some agitation with the head of the tool to obtain optimum results. Follow up with a few additional vacuum strokes. The purpose of the pre-spray and the optimal use of the "Upholstery Scrub Head" I to give you that "cleaning edge" over the competition.

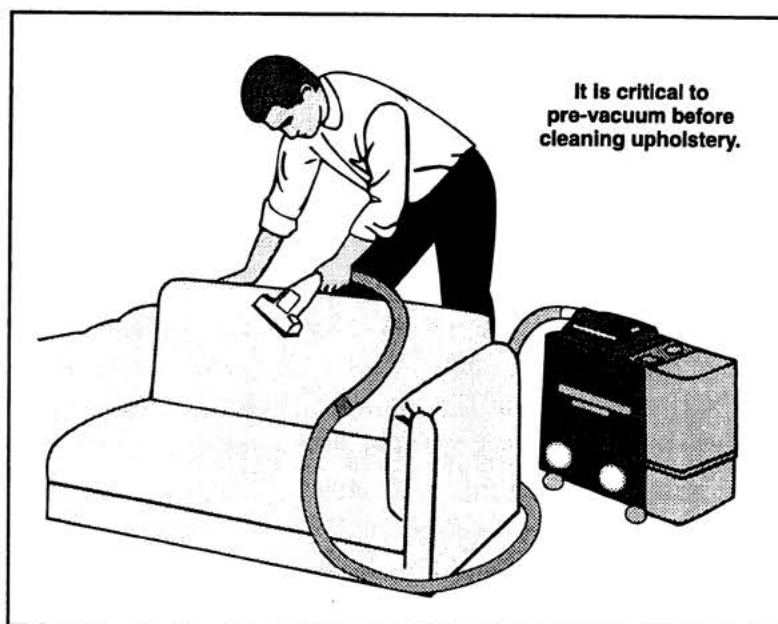

An alternative basic cleaning procedure is to fill a hand spray with Magic Fabric Cleaner and spray the entire piece to be cleaned; wait 3 to five minutes (dwell time). Next, add two ounces of tannin acid to the clean water in the holding tank and proceed with the normal spray and vacuum strokes. By using the clear water rinse and tannin acid mixture, the detergent residue is eliminated. The tannin acid also reduces the chance of "browning" on light or white fabrics.

Agitation or use of the "Upholstery Scrub Head" is not needed on very light areas, such as the underside of cushions or the outside of the furniture. Simply spray and extract (usually one pass is all that is necessary).

CLEANING ORDER: Always clean the cushions first using a portable worktable or a clean drop cloth spread on the floor. Never clean the cushions in a place as bleeding (transfer color) may occur. It is best to clean half of the most soiled cushion first and the customer see the result. This shows the customer the quality of the work being done.

Once the cushions are cleaned, place them on freezer wrap paper spread out on the floor (plastic coated side down). Never place the wet cushions back on the couch, as the platform of the cushion may bleed into the cushions. If freezer wrap is not available, use a clean plastic drop cloth.

The best way to dry cushions is to "teepee" them on the paper. This allows the air to completely envelope all sides of the cushion. Set up a speed dryer to accelerate drying time.

PRESPRAY

Prespray the heavily soiled areas and let set before normal spray and vac procedure.

When wet cleaning, let set for 5 minutes.

When dry cleaning, let set for 10 minutes



DRYING CUSHIONS

"Teepee" cushions on paper to allow air to reach all sides. If using a speed dryer to accelerate drying, direct air to inside of teepee.

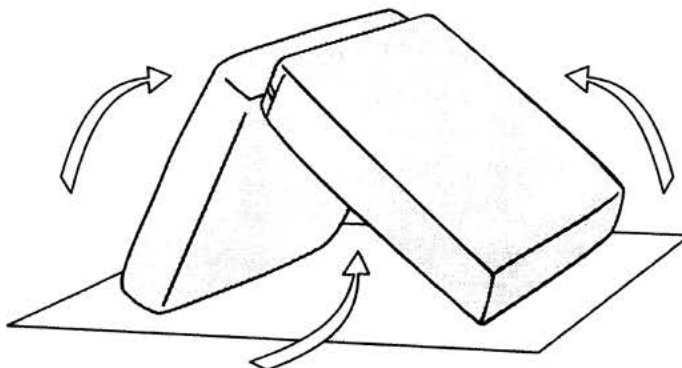

With sofa on its back, clean kickboard and skirt areas first.



Before cleaning the body of the sofa, lightly spray-mist the entire platform. Many times the platform has been treated with a water based sizing. If a drip or solution overspray the platform, it could partially dissolve the sizing and leave water marks. Pre-spraying the platform will blend out any drips or overspray. Clean the platform last and it will dry evenly. Another method is simply to protect the platform with a plastic drop cloth or a large beach towel with the edges tucked in.

To proceed, place the sofa on its back. Clean the kickboards and the skirt areas first. Next, do the front of the arms followed by the inside back of the sofa. When these areas are cleaned, set the sofa upright. Using a crevice tool, vacuum the crevices of the sofa (do not use your hands, as you may encounter sharp objects). Next, clean the top back, then the top and insides of the arms and finally the platform itself. This leaves the outside of the body to be cleaned (which is rarely soiled). Spray large portions at a time and vacuum quickly. This procedure should only take 3 to 5 minutes. To create the finishing touch, place a small amount of furniture polish on a clean cloth and detail the wood parts of the sofa.

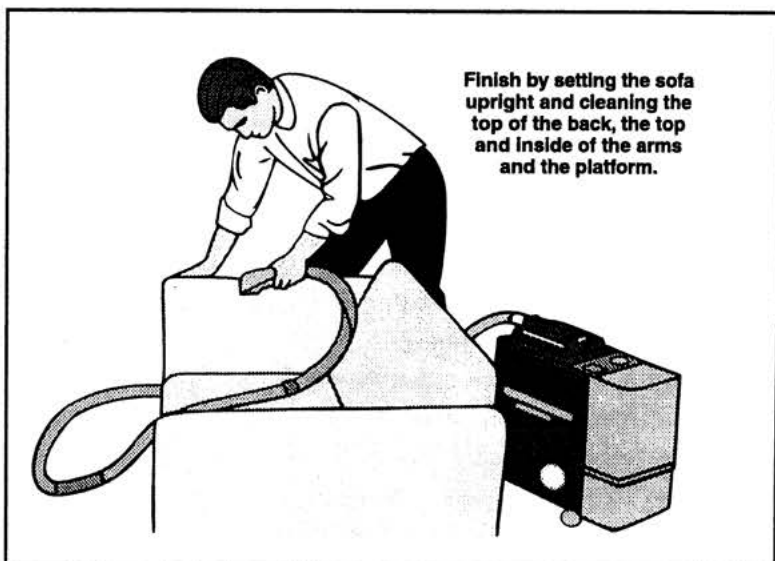

DRY CLEANING:

The only difference between the dry cleaning procedure and the wet cleaning is dry cleaning solvent is added to the holding tank instead of detergent. (NEVER ADD WATER TO A DRY CLEANING SOLVENT!)

THE DRY-WET-DRY METHOD:

This is a form of dry cleaning reserved specifically for bleeders and Haitian Cotton. Although these fabrics can certainly be dry cleans, the dry-wet-dry method is an alternative method. This author prefers the dry cleaning method, since the dry-wet-dry method does not always perform well.

PROCEDURE:

Spray the fabric with a non-chlorinated solvent (Formula #800). The solvent will penetrate the fabric and create a barrier around the dye. Next, mist the water based pre-spray over the area just treated with the solvent. The solvent will repel the pre-spray so it cannot attack the dye. There will be enough surface penetration to dissolve the surface soil. Next, using your machine, make two or three spray passes with hot water (approximately 180 degrees). Vacuum up the pre-spray, soil and excess solvent that has not been absorbed into the fiber. Spray more solvent on the fabric (as insurance) and make a final vacuum pass to finish the procedure. To allow for better control, do not work in an area larger than 20" square at any one time. This procedure may be repeated as often as necessary to obtain the desired result. Caution, if too many cleaning passes are made without applying additional solvent, there is a risk of removing the solvent protecting the dye.

CLEANING VELVETS:

Before discussing techniques for cleaning velvet, it is important to go over some of the basic information on the fabric itself. There are two methods the manufacturer uses for attaching the pile to the backing material, the "V" weave and the "W" weave. The "V" weave winds around the yarn once, whereas the "W" weave alternates under and over the yarn before it is brought back up. The "W" weave is much stronger. If you pull on the weave and it comes out easily it is a "V" weave. Because of the "V" weave, a latex backing is usually applied to keep it in place. The latex gives the weave stability and therefore, does not present a cleaning problem. When cleaning a "V" weave without latex backing, there is a risk of the pile falling out leaving bold spots. Be sure to check for this condition on all velvets.

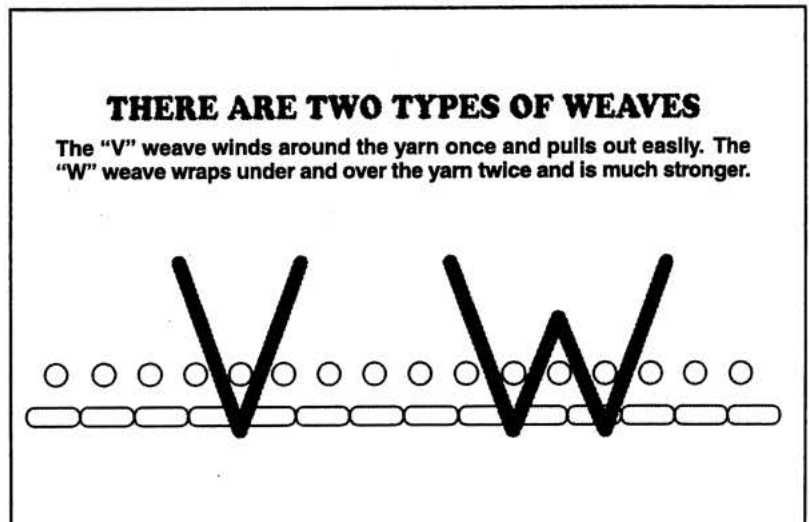

Velvets are manufactured in cut and uncut piles. They are made up with a soft pile of loops of warp thread either cut to the outer end (as ordinary velvets) or left uncut (as an uncut or terry velvet). The velvet pile can vary in length. The longer the length are referred to as "plush" velvets. "Velveteen" is 100% cotton fiber with 100% cotton backing, and usually has a short pile.

Crushed velvet refers to a pattern that is set into a pile. Velvets can be either natural or synthetic. Natural velvet is crushed with live steam during the manufacturing process and allowed to dry. Synthetic crushed velvet are permanent because the pattern is actually fused into pile yarns. The synthetic velvet can be wet cleaned just like any other fabric. Take extra care when cleaning natural velvet, however, it does not leave a permanent pile. Moisture will relax the pile causing it to mat, and the crushed pattern is then lost. Wet cleaning will remove the "crush", whereas dry cleaning will not. Use the same procedure as you would in the bleed test to determine whether you are working with natural or synthetic velvet. If the spot test dries matted, it is a natural velvet. If it dries without any distortion, it is a synthetic velvet.

It is always best to dry clean natural velvet. If, however, the velvet is extremely dirty, and you feel the customer will not be satisfied with the results, then it can be wet cleaned. Be sure and let the customer know that the crushed look will be removed in the process. When the cleaning procedure is completed, use a special velvet (wire) brush to bring up the nap and restore the pile.

One method to restore the “crushed” look, is to use a speed dryer to alternately brush and dry the fabric until the desired affect is achieved. This procedure is very time consuming and can develop into a “headache”, especially for the beginner. We strongly recommend dry cleaning as your #1 choice. If you want to know more about this procedure, call or write HydraMaster.

RUSTY BUTTONS OR STABLES:

Actually the cleaners themselves create this problem. Rust never appears on the fabric during cleaning, it is notices days later. To remove these rust stains, place an aluminum or plastic shield around the button and apply the rust remover. The affect on rust is almost instantaneous. It will disappear right before your eyes. You must now neutralize the acid or it can continue to work and cause additional rust, as well as leaving hazardous residue in the fabric. There may be a wisp of smoke as the ammonia reacts to the acid. This is normal and there is no cause for alarm. Finish up with one or two spray/vac strokes. Now spray the button with silicone to prevent future problems. Always silicone metal buttons immediately after cleaning to prevent rust from forming. The silicone will coat the button without affecting the fabric.

Always test both the ammonia and the acid in an inconspicuous area before using. If the rust remover turns the fabric a different color, do not panic, the ammonia will neutralize the chemical reaction and restore the original color. There are safer, milder acid formulations that remove rust, but they work slower. Must rust removers contain hydrofluoric acid and are very hazardous, so handle with care and use gloves for protection. Rinse thoroughly if any of the solution touches the skin.

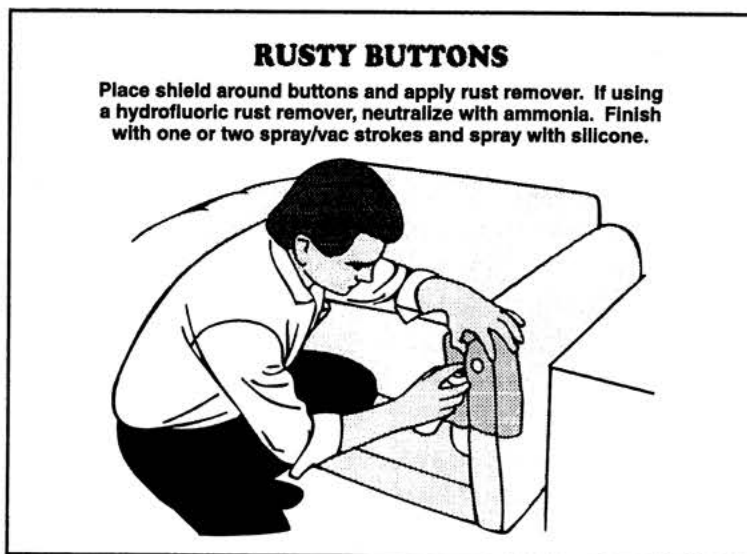

TOOLS OF THE TRADE:

A large briefcase or sample case is excellent for carrying all tools and testing equipment. You can also appear professional.

The one gallon pump-up sprayer is used for a larger spray applications and is also handy for removing hidden stains and that surface while cleaning. Pump up the sprayer and spray air into the strain, driving it back and down into the fabric. Continue this procedure until the area is dry, or it may resurface. Another method is to insert the exhaust port of your machine. With the vacuum on, using the end of the exhaust hose, drive the stain down into the fabric.

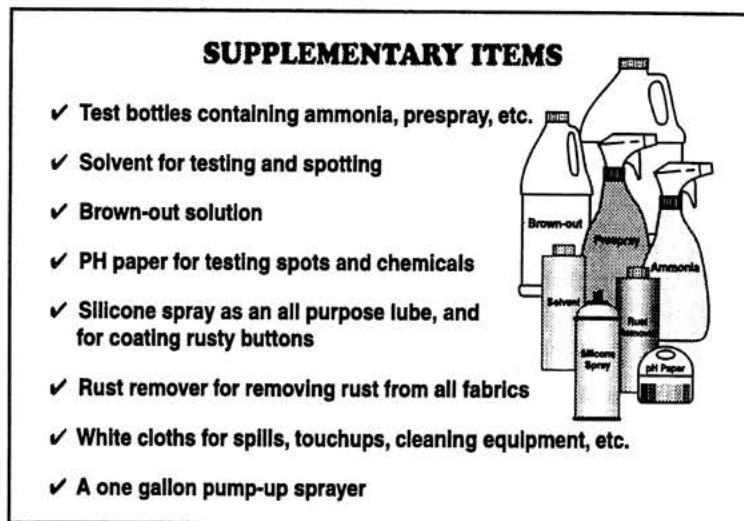

One method to restore the “crushed” look, is to use a speed dryer to alternately brush and dry the fabric until the To use stapler and pliers for inspecting fabric on the underside of the upholstery, turn the piece on its back, remove a few staples, inspect the fabric and the restaple.

The only time this is necessary, is when there is no other way to inspect both sides of the fabric.

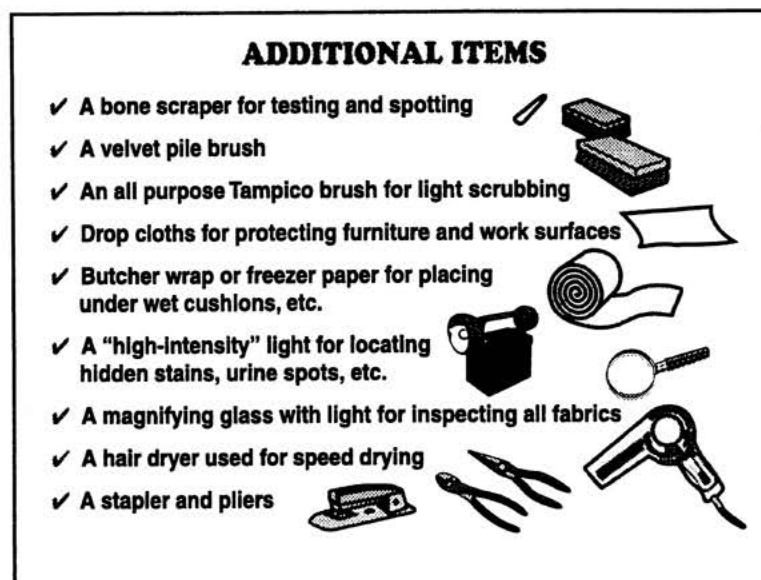

ON-SITE DRAPERY CLEANING:

On-site drapery cleaning is more profitable than upholstery or carpet cleaning and easier to do. Only 5% of the professional cleaners today are cleaning draperies whereas 95% are only cleaning carpets. Drapery is still a virgin market.

Have you ever experienced taking draperies into the dry cleaners? The in-plant dry cleaners will not guarantee the cleanability of the draperies. Normally, they will have you sign a waiver relieving them of all responsibility in the event the draperies shrink or come out damaged. Draperies can now be cleaned right where they are hang and you can actually guarantee they will not shrink or be damaged. Let the customer know that hanging up sheets or “living in a fish bowl”, is now unnecessary.

It is important to note that in-plant dry cleaning soaks the sizing and flame retardant out of the draperies, leaving them limp with no protection. Continued in-plant cleaning will have a cumulative effect, shortening the life span of the draperies, accordingly. On-site dry cleaning removes dirt “off” the sizing (leaving the sizing in) which extends the life of the draperies. They will have a better appearance because the body of the drapery is left intact.

Hotels, motels and institutions are just waiting for your on-site cleaning service. They lose thousands of dollars every year in draperies that come back shrunken or damaged from the in-plant dry cleaners, plus lost time in hanging up loaners, taking them down and rehanging the originals.

The average charge for cleaning draperies is \$1.5 to \$2 per pleat (Add \$.5 to \$1.00 per pleat in “upper end” markets). With practice, professional cleaner should be able to clean 60 pleats per hour.

Approximately 30 pleats can be cleaned with each gallon of cleaning solution thus being enabling the professional to earn a net income of \$75.00 to \$100.00 per hour.

DRAPERY DESCRIPTION:

The "header" is at the very top of the drapery. This is actually the top of hem. The "header" is stiffened by the insertion of a cardboard type material referred to as the "buckram" or the "crinoline". This material can be affected by over wetting with a water based cleaner, however, non-chlorinated solvents will not affect this material. The bottom hem, which is the lowest part of the drape, contains weights that allow the drapery to hang evenly, and last are the side hems which finish the drapery. The draperies are seamed together in widths of 48", which is referred to as the panel. Cost estimates can be based on how many panels to a drape, however, the best and simplest way is to bid is by the pleat.

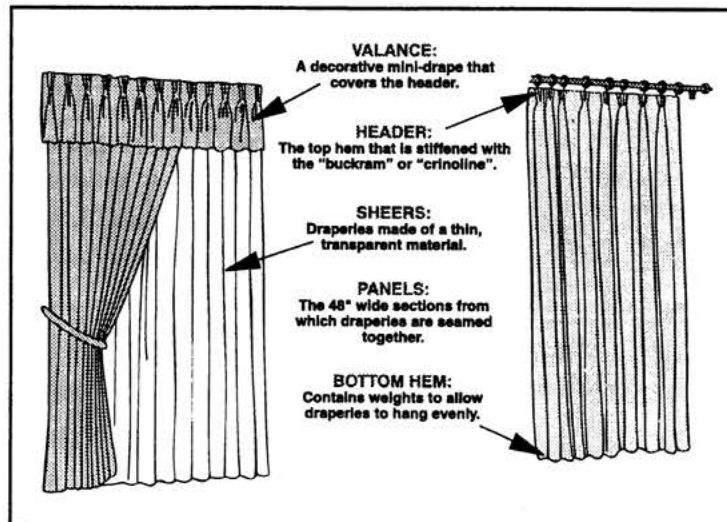

The valance gives a decorative effect. It is actually a miniature drape that covers the header. The cornice box is similar to a valance. Some are made of decorated wood, but most will be covered with a padded fabric. These are very easy to clean on-site, but the in-plant cleaner will turn them down. Swags and pleated valances are custom installed and if ever removed, rarely are rehung again. The in-plant cleaner will avoid these also, therefore, this is an excellent source of income for the on-site cleaner.

DRAPERY FABRICS:

Most draperies are made of natural fiber or a combination of natural and synthetic material. Synthetic materials don't shrink and therefore, are wet cleanable. A burn test is necessary to determine whether the fabric is synthetic or natural. Cut off a small piece of excess fabric from behind the header or one of the hems. To be safe, burn the material sample in an ash tray. If the fabric turns to a soft ash, it is definitely made of natural fiber. If it turns into a hard black bead, it is a synthetic. If the degree of hardness is questionable, the fabric may be a combination of natural and synthetic fibers and should then be treated as a natural material.

Generally speaking, 80% of the draperies are made from natural fabric, the other 20% are made from a synthetic material and can be wet cleaned. These percentages are changing as more manufacturers are adding additional synthetics to their line. If there is any doubt as to whether the draperies are natural or synthetic, dry clean them.

SHEERS: The sheer is a thin, transparent material usually made from a synthetic fabric, however, some are made from natural fabrics. The sheer drape is not only decorative, but is used for privacy and to help screen the sun's rays.

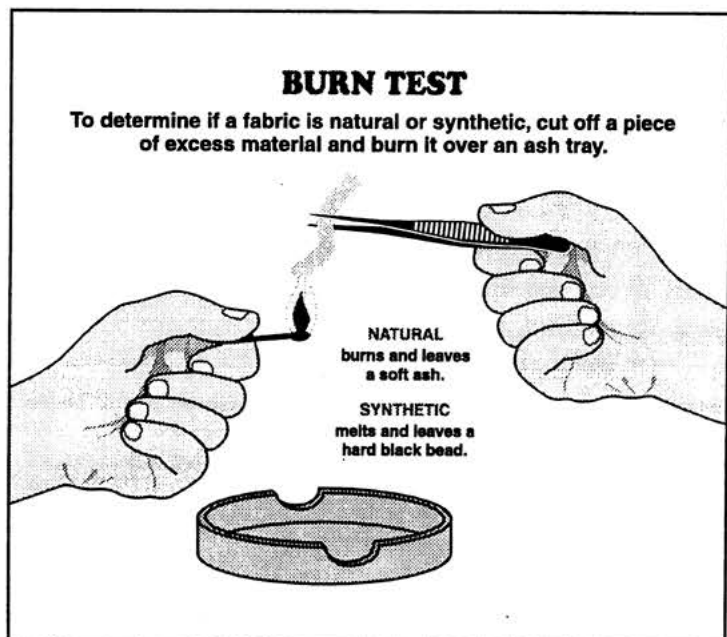

BACKED OR LINED DRAPES AND BLACKOUTS:

Some draperies are manufactured with a lining or backing. The lining gives a finished look and offers more protection for the drapery, thereby extending the life of the fabric. Latex backed draperies are a type of lined drape. In place of a material sewn to the back of the drapery, latex or a rubber substance is fused to the material. Sometimes this fused material is made of vinyl and is referred to as vinyl-backed drapes. Hotels and motels use these types of drapes and refer to them as "black-outs". They are easily wet cleaned, as the backing keeps them from shrinking. Caution should be taken not to clean above 125° F, or the backing may bubble. Most in-plant dry cleaners will not clean latex-backed drapes because the chlorinated solvent will destroy them.

ANTIQUE SATIN: One fabric that is popular, is Antique Satin. The fluffy fibers that run crossways will make this fabric easy to identify. Antique Satin is a combination of rayon and acetate, which shrinks very easily. As a result, most in-plant cleaners will refuse to clean this type of drape. You can safely clean this type of fabric with the on-site method.

FIBERGLASS DRAPES: Fiberglass drapes are easily identified also, and since they are 100% synthetic, can be safely wet cleaned. Fiberglass is a material consisting of extremely fine filaments of glass which are combined in a yarn and woven into fabric. It is completely fireproof and there, is very popular in public buildings, schools, hospitals, etc.

When cleaning fiberglass drapes, be aware that invisible shedding occurs and it is possible for particles to get into the eyes or skin of the cleaning technician. Eye protection and gloves are advised.

INSPECTING THE DRAPERIES:

The procedure for inspecting the draperies is very basic. Start at the top and check for the header. Is the buckram smooth, does it appear distorted or damaged? Is the header frayed from touching the ceiling? Does the header sag forward thus allowing the draperies to sit on the floor? These conditions can be due to improper installation and should be brought to the customers attention. Note the condition of the header on a check list.

Check all hems, as threads can break and the hems unravel. This can be a simple repair job. Inspect the entire drapery for holes, tears and damage of any kind. If the back of the drapery is lined, inspect for water marks and pet stains. These are the worst stains to remove and rarely comes out. "Brown Out" solution, rust remover, or a 3% solution of hydrogen peroxide may be effective in removing these stains, but remember, these are no guarantees. Note all conditions on the check list. Next, check the traverse rod cord. If the tension is lost, it can be tightened by adjusting or replacing the tension pulley. This is easy to do and you may charge extra for this service.



DRAPERY INSPECTION

- ✓ **CHECK THE HEADER**
 - Is it frayed from touching the ceiling?
 - Does it sag forward allowing the draperies to sit on the floor?
 - Is the buckram smooth, is it distorted or damaged?
- ✓ **CHECK HEMS**
 - Are threads broken?
 - Are they unraveling?
- ✓ **CHECK ENTIRE DRAPERY**
 - Are there holes, tears or other damage?
 - If back is lined, are there water marks or pet stains on lining?
- ✓ **CHECK TRAVERSE ROD CORD**
 - If tension is lost, tighten by adjusting or replacing the tension pulley.

Note all conditions and have the customer sign or acknowledge a statement of pre-existing conditions.

Before cleaning, you may want the customer to sign a statement of acknowledgement that he/she is aware of all pre-existing conditions noted on your check list.

TESTING THE FABRIC:

The testing procedure for drapery fabrics is the same as testing upholstery fabrics. Do a bleed test behind the header or in an inconspicuous area, and remember, it is important to test each color separately. If the fabric is all one color, there is no need for testing for bleeding. The test for fabric strength is done with a bone scraper at the rear of the pleat where there is more exposure to the sun. Do this test 3 or 4 pleats. Holding the bone scraper at a 45-degree angle to the fabric, drag the scraper slowly and gently downward. Do the same procedure horizontally across the drapery. Look for any fibers that have broken or spread apart excessively. The seams that hold the widths together are sometime weak and should also be tested.

Weak fabric can be cleaned on-site, it just requires a gentler action. Inform the customer the drapery has weak areas, but it can be cleaned. Let the customer know that if the drapes were taken to the dry-cleaners, they would most likely fall apart. A second method of testing the drape is to gently pull and twist the fabric. This test is done with the pleats that are closest to the window. Listen for cracking and inspect any separation of the fabric. When a bone scraper is not available, this test will suffice. Inspecting and testing the drapes takes only a few minutes and should always be part of your procedure. Damaging draperies is very rare if the correct procedure is followed and the right equipment and tools are used.

PREPARATION FOR CLEANING DRAPERIES:

Using a ladder, clamp one corner of a 4-mil plastic sheet to the end of a wall bracket (before clamping, double the plastic at the corners for extra strength). Now, draw a plastic sheet behind the drapery and clamp it to the other side. The plastic sheeting protects the walls and windows from overspray and help the back of the draperies to better vacuum. Place a drop cloth under the draperies to protect the floor or carpet from overspray. If the spray does come in contact with the walls or windows, just let it evaporate, do not try to wipe it off, or it will create dirt smears.

All lined draperies should be cleaned on both sides. If they are not lined, the header should still be cleaned on both sides. The rest of the drapery can be cleaned form the front only. The suction of your vacuum will draw the dirt from the back of the drapery to the front, and both sides will be cleaned at the same time.

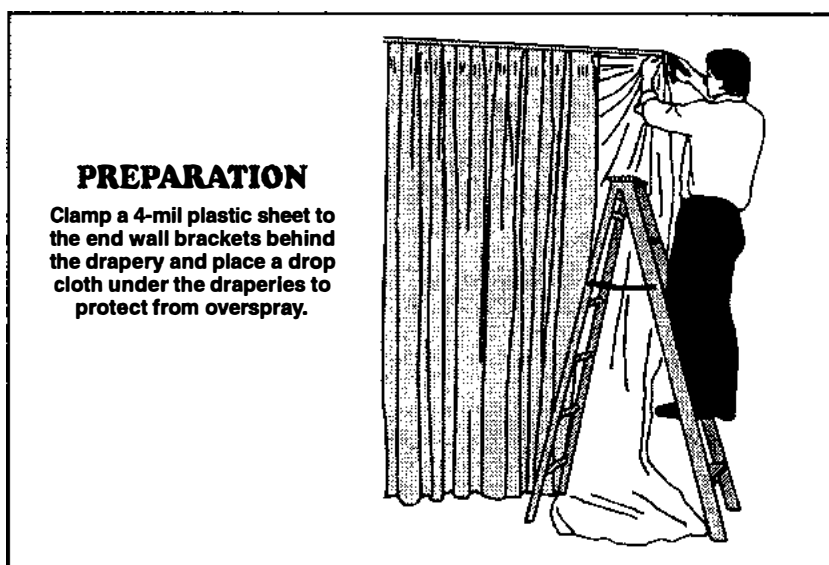

If the back of the drapery has to be cleaned, do the back first. Unpin one half of the drapery and fold it back across the other half, and clamp in place. This is a good time to wipe the rod and lubricate it with an all-purpose silicone spray. This service should be a part of the original presentation to your customer.

A snap ring, string or wire secured to the vacuum line and pressure hose, can be attached to your belt loop, which will help to eliminate the weight of the hoses. If you prefer, drape the hose and pressure line over your shoulders. Before cleaning, use a crevice tool to vacuum out the pockets behind the header where insects may live and lay their eggs. This service should be part of your presentation.

The most soiled part of the drapery is the upper 20%. To clean this area, begin at the top, making horizontal vacuum strokes across the pin area, the pre-spray with "Synergizer". (Mix per instructions.) Wait 10 minutes to take full advantage of the working action of the pre-spray. Follow up with the normal spray and vacuum strokes. The rest of the drapery should be cleaned by spraying the solution and vacuuming simultaneously, using the drapery tool. The very bottom of the drapery should be done with horizontal strokes, otherwise it is possible to overspray onto the floor as the tool passes over the bottom hem. Now, repin the drapery and clean the other half.

The procedure for cleaning the front of the drapery is the same as for cleaning the back. To eliminate setting up for scaffold, or having to climb up and down a ladder, the following is a time saving method for cleaning drapes. Set up a ladder at the center of the drapes. Next, unhook the last pin at each end of the draperies (this allows them to slide freely), the standing on the ladder draw the draperies toward you as you clean.

Start the cleaning procedure by vacuuming and pre-spraying the header (same procedure as for the back). Follow up with horizontal spray and vacuum strokes, right to left across the header and then switch hands and clean left to right. Repeat spray and vacuum strokes if needed. Next, do the area just below the header as far down as you can comfortably reach. Remove the ladder and then clean the body of the drape, dividing the draperies into sections, working one section at a time until completed. Remember to re-pin the drapery when finished.

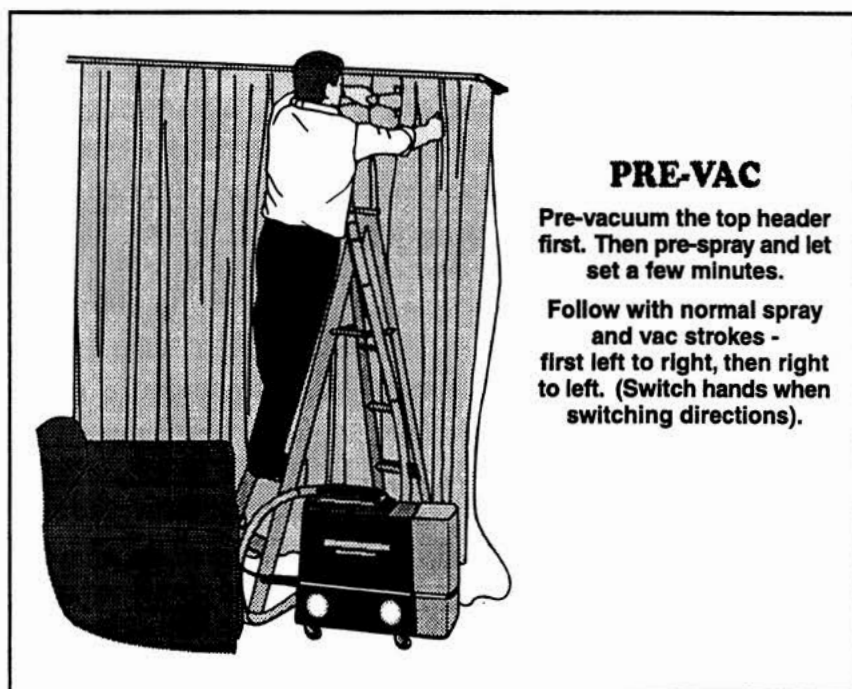
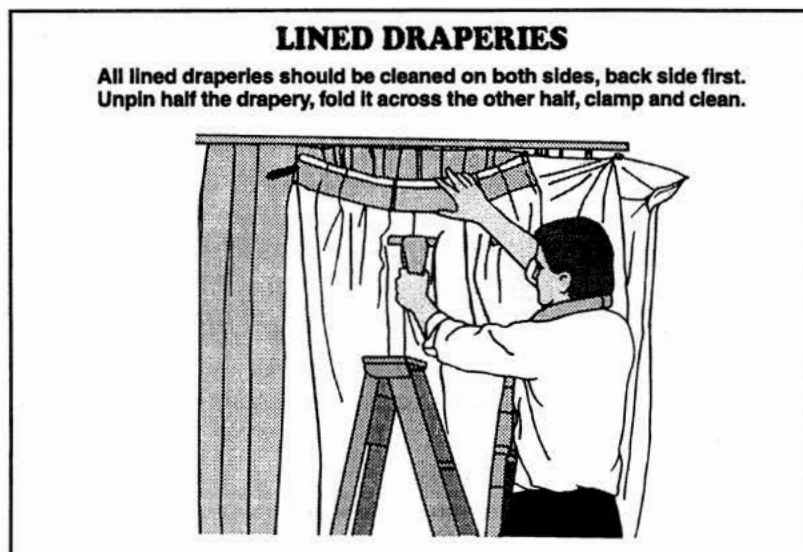

CLEANING SHEERS:

Clean sheers first, using the same procedure as for cleaning drapes. Sheers are usually made from synthetic fabrics, such as nylon, dacron or polyester. These fabrics can be wet cleaned. If these fabrics are natural, dry clean them. (When in doubt do the burn test.) Add 1 oz. of bleach to the dry or wet cleaning solution to enhance the results. Although it's not standard practice to mix bleach with dry cleaning solvent, sheer is the exception.

When wet cleaning and dry cleaning on the same job, do all the wet cleaning first to avoid having to change the solution more than once. Wet cleaning draperies or sheers, unlike dry cleaning, can cause water spots or streaks unless the correct procedure is followed. Starting at the top could cause a problem, when wet cleaning, start at the bottom and spray the entire fabric evenly, then clean from top down.

When the cleaning procedure is finished, crease the pleats between you thumb and forefinger or with the palms of your hands, as you move downward over the drapes. Tie the draperies back with a white ribbon or a paper band: they should remain tied back for 3 or 4 hours. This procedure gives a professional, finished look to the draperies. If the customer prefers more popular, softer decorative fold, do not place such strong emphasis in the crease of the pleats. The palm action works best for this effect. Tie drapes back for fished look, or just leave them slightly open. If they are not tied back, you lose the psychological edge of the "finished" look.

Cleaning cornice boxes, lambrequins and pleated valances, do not present any special problems.

The best way to clean swags and Roman valances, that have horizontal folds, is to use horizontal strokes. Vacuum the dust that has been settled in the strokes, then pre-spray and follow with vacuum stroke. It is best to begin at the bottom of the swag and work upward, one pass at a time. Adjusting the folds with you free hand will enable you to clean across a flat surface.

To clean hanging tassels, place a white towel behind the as a backing and for support, then spray and vacuum.

Although most fringes are sewn into swags, there are some that are glued on. Before cleaning, test a small area to be sure that the solvent will not affect the glue. If the solvent does dissolve the glue, you have to reinforce the fringe by sewing it in place. Charge accordingly.

WRINKLE REMOVER:

Wrinkle remover works well on natural fabrics, but does not work on synthetics. Wrinkles on synthetic fabrics will have to be pressed out. Wrinkles must be removed prior to cleaning. If you wish to remove wrinkles after the draperies have been cleaned, wait until they are completely dry. To remove wrinkles, spray a fine mist across the wrinkled area, then take a white towel and press the wrinkles out. Do not work the area too hard, or you might stress the fabric.

Some wrinkles removers have a poor shelf life. Do not use a product that is older than six months as it may cause water rings on the fabric. Steam guns can take out wrinkles too, but they can be tricky to use and may leave water marks or shrink the draperies if in the hands of an inexperienced operator. Practice first on discarded drapes.

ADDITIONAL INSTRUCTIONS & PRICING INFORMATION

WOVEN WOODS: Woven Woods have become very popular; these too can be cleaned on-site. The in-plant cleaner cannot clean Woven Woods, so it is an excellent new market pursue. Woven Woods can be wet cleaned very successfully, but do check for color stability before starting. In most cases, the wood is protected by a factory finish. To start, place a plastic drop cloth behind the Woven Woods, and beneath them on the floor. Simply spray and vacuum: one or two passes will be sufficient. There is no need to use scrubbing stroke. If you are concerned about the wood finish on an old Woven Wood, or the material bleeds, then dry clean. Charge the customer \$1.50 to \$2.50 per square foot to wet clean; add 50% to 100% more for dry cleaning.

VERTICAL BLINDS: The 4" fabric covered Vertical Blinds will sometimes separate if wet cleaned, however, they can be dry cleaned successfully. Always test a small area before cleaning. The average charge is \$1.50 to \$2.00 per slat.

LAMP SHADES: Place the shade in a large tray; a kitty litter tray works well. Mist the entire shade with "Synergizer" in a hand sprayer and let set 10 minutes. With solvent (Formula #800) in your holding tank, pressure spray the dirt downward using a spray wand connected to your machine. It is best to clean the shades at your place of business. Charge from \$15.00 to \$20.00 per shade. Also, do not overlook mattresses, they can also be wet cleaned successfully. Charge from \$25.00 to \$50.00 for both the box and spring mattress.

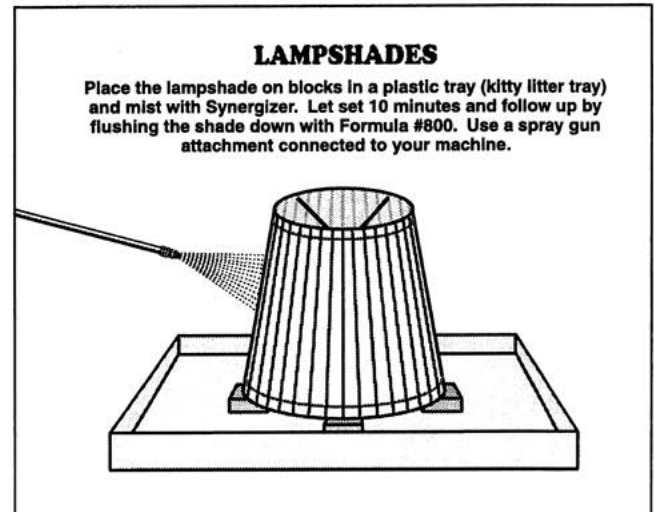

DRAPERIES: Charge \$1.50 to \$2.00 per pleat if the drapery does not have a lining. Charge an extra .50 per pleat if the drapery does have a lining (add \$.50 to \$1.00 in the "upper end" markets). To be safe dry clean most draperies (only wet clean synthetic fabrics). The average charge to clean draperies on-site is \$200.00, which will net you between \$70.00 to \$100.00 per hour.

PLEATED SHADES: Pleated shades can be successfully wet cleaned. With the new fabrics coming on the market it would still make sense to evaluate the material before proceeding. Dry cleaning is always an alternative. Charge approximately .50 per square foot for wet cleaning. Add an extra .50 for dry cleaning.

PRICING UPHOLSTERY (WET CLEANING):

SOFA: When wet cleaning sofas, charge \$7.00 - \$12.00 per lineal foot. The price will depend on the amount of cushions cleaned, the color (white being more expensive) and the areas that need detailing: such as buttons, quilting, skirts and flouncing.

FULL-SIZED UPHOLSTERY CHAIRS: The charge per chair is \$25.00 to \$40.00, depending in the size and the difficulty of cleaning.

PRICING UPHOLSTERY (DRY CLEANING):

Add a minimum of 50% to 100% above your wet cleaning charge. Doubling the charge would not be excessive – after all, you are dry cleaning the customer's fine fabric upholstery the same as the in-plant dry cleaner cleans his customer's fine clothes.

BOX SPRING & MATTRESS: Charge between \$25.00 and \$50.00 per box mattress depending on size.

Remember, as previously stated, when dry cleaning, always pre-spray the entire piece with "SYNERGIZER" (mixed per instructions in a hand sprayer). Let set 10 minutes ("dwell" time is important when dry cleaning), then, using formula #800 in the holding tank of your dry cleaning machine, (Ultimate PBIII) proceed with the normal spray and vacuum strokes. Solvents are always used full strengths. Be safe rather than sorry, when in doubt always test the fabric to be cleaned in an inconspicuous area.

When out in the field, always be aware of the different fabrics that need cleaning. Many buildings now have carpet or fabric wall coverings and fabric partitions. Automobiles, airplanes and yachts all have upholstery and are a good added source of business. The opportunities are unlimited. If you require additional information, please contact HydraMaster at 1-800-426-1301.

If 95% of the window treatments you're cleaning are pleated draperies, you're missing...

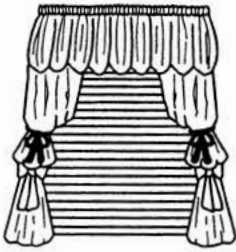

Bishop Sleeve Draperies

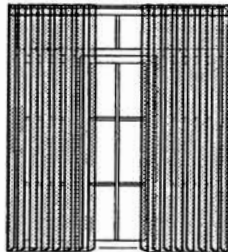

Luminettes



Shirred Lambrequin with Sheers & Side Panels

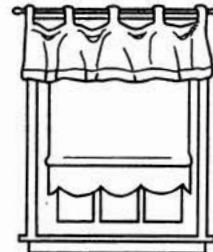

Tab Valence & Roller Shade with Decorative Hem

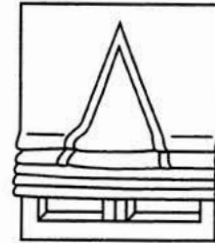

Flat Roman Shade

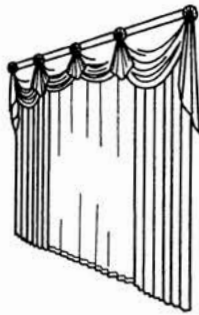

Pick-up Swag Valence over Drapes & Sheers



Empire Swag with Sheers & Side Panels

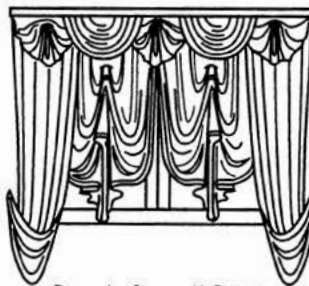

Decorative Swags with Drapery Side Panels & modified Balloon Shade



Shirred Swags with Cornice & Stacked Cascades

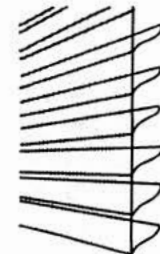

Silhouettes

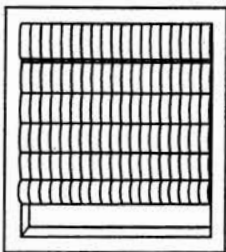

Woven Woods

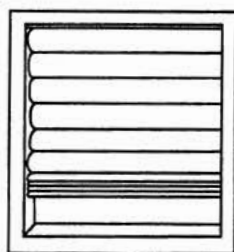

Hobbled Roman Shade



Fabric Vertical Blinds with Formal Swag Valence

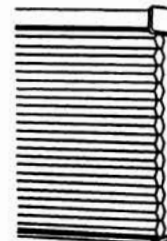

Duettes

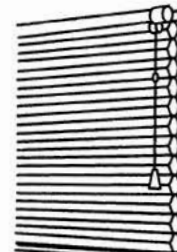

Cellular Shades

With the ULTIMATE PBIII System, you can offer to clean all these window coverings safely, easily and effectively right in your customer's home or business and

Increase Your Income to \$70 - \$100 Per Hour!

ABC Cleaning Company

Inspection Form

(sample)

DRAPERIES

PLEATS OR _____

WIDTHS _____

LENGTH _____

COLOR _____

AGE _____

DRAPE DESIGN _____

CHECK FOR THE FOLLOWING:

HOLES/TEARS _____

DRY ROT _____

SUN DAMAGE _____

WATER MARKS

STAINS _____

SEAM CONDITION _____

HEM CONDITION _____

HEADER _____

DRAPE SAG _____

ROD & CORD _____

PULLEY

OTHER _____

COMMENTS _____

UPHOLSTERY

COLOR _____

AGE _____

TEXTURE _____

DESCRIPTION _____

CONDITION OF THE FOLLOWING:

CUSHIONS _____

ARMS _____

BACK _____

WOOD TRIM _____

PLATFORM _____

CAMBRIC FAB _____

BLEED TEST RESULTS _____

OTHER _____

COMMENTS _____

I am aware of the pre-existing conditions and authorize the ABC Cleaning Company to clean the upholstery and/or the draperies.

Date _____



800.426.1301 / 425.775.7272
11015 - 47th Avenue West / Mukilteo, WA 98275

www.hydramaster.com