

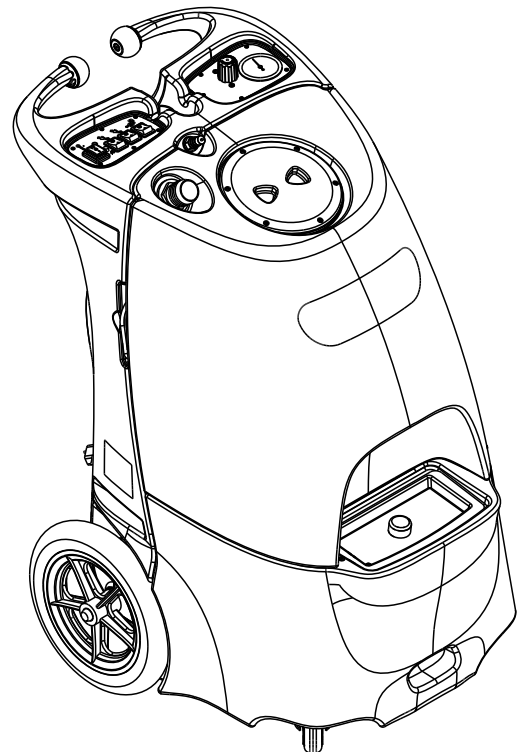

PEX 500-C-TICK

INFORMATION & OPERATING INSTRUCTIONS



MODEL: 56384886



**CAUTION: DO NOT OPERATE MACHINE UNTIL YOU HAVE READ
ALL SECTIONS OF THIS INSTRUCTION MANUAL**



IMPROPER USE OF THE MACHINE WILL VOID THE WARRANTY

TABLE OF CONTENTS

	Page
Introduction	A-3
Parts and Service	A-3
Nameplate	A-3
Uncrating the Machine.....	A-3
Cautions and Warnings	A-4
Grounding Instructions	A-5
Know Your Machine	A-6 – A-7
Know Your Switch Plate.....	A-8
Preparing the Machine for Use	A-9
Operating the Machine	A-10 – A-11
After Use	
After Using the Machine	A-12
Maintenance	
Maintenance Schedule	A-12
Power Cord Maintenance	A-12
Troubleshooting.....	A-13
Technical Specifications	A-13
SECTION II – Parts List	15
Decal System	16-17
Pallet System 500-1 C-TICK	18-19
Pallet System 500-2 C-TICK	20-21
Recovery System	22
Solution System.....	23
Wiring Diagram.....	24-25
Options & Accessories.....	25
Water Flow Diagram.....	26

INTRODUCTION

This manual will help you get the most from your HydraMaster carpet extractor. Read it thoroughly before operating the machine.

This product is intended for commercial use only.

PARTS AND SERVICE

Repairs, when required, should be performed by your Authorized HydraMaster Service Center, who employs factory trained service personnel, and maintains an inventory of HydraMaster original replacement parts and accessories.

Call the HYDRAMASTER DEALER named below for repairs or service. Please specify the Model and Serial Number when discussing your machine.

MODIFICATIONS

Modifications and additions to the cleaning machine which affect capacity and safe operation shall not be performed by the customer or user without prior written approval from HydraMaster. Unapproved modifications will void the machine warranty and make the customer liable for any resulting accidents.

NAMEPLATE

The Model Number and Serial Number of your machine are shown on the Nameplate, located on the rear base of the machine. This information is needed when ordering repair parts for the machine. Use the space below to note the Model Number and Serial Number of your machine for future reference. Be sure to register your warranty online at www.hydramaster.com/Support/WarrantyRegistration.aspx

MODEL _____

SERIAL NUMBER _____

UNCRATING THE MACHINE

When the machine is delivered, carefully inspect the shipping carton and the machine for damage. If damage is evident, save the shipping carton so that it can be inspected. Contact the HydraMaster Customer Care Department immediately to file a freight damage claim at 800.426.1301.

IMPORTANT SAFETY INSTRUCTIONS

This machine is only suitable for commercial use, for example in hotels, schools, hospitals, factories, shops and offices other than normal residential housekeeping purposes.

When using any electrical appliance, basic precautions should always be followed, including the following:

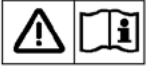

NOTE: Read all instructions before using this machine.

WARNING!

To reduce the risk of fire, electric shock, or injury:

- This machine is not intended for use by persons (including children) with reduced physical, sensory or mental capabilities, or lack of experience and knowledge.
- Do not leave the machine unattended when it is plugged in. Unplug the unit from the outlet when; not in use, before cleaning the machine, prior to servicing or performing any maintenance on the machine, and when replacing parts or converting the machine to another function.
- To avoid electric shock, do not expose to rain or snow. Store and use machine indoors only, store in a heated location. Do not let the machine or wand freeze.
- Do not allow to be used as a toy. Close attention is necessary when used near children.
- High pressure cleaners shall not be used by children or untrained personnel.
- Use only as described in this manual. Use only the manufacturer's recommended attachments.
- Never add water over 130° F/54° C to the solution tank.
- Always use a defoamer when foaming occurs to prevent vacuum motor damage.
- Do not let the pump run dry.
- Do not use with damaged cord or plug. If the machine is not working as it should, has been dropped, damaged, left outdoors or dropped into water, return it to a service center.
- Turn off all controls before unplugging.
- Do not pull by the cord, use the cord as a handle, close a door on the cord, or pull the cord around sharp edges or corners. Do not run the machine over the cord. Keep the cord away from heated surfaces. To unplug, grasp the plug, not the cord.
- Do not handle the plug, the cord or the machine with wet hands.
- Extension cords must be 12/3 and no longer than 50 feet. Replace the cord or unplug immediately if the ground prong becomes damaged.
- Connect to a properly grounded outlet only.
- Do not put any object into openings. Do not use with any opening blocked; keep free of dust, lint, hair, and anything that may reduce air flow.
- Keep loose clothing, hair, fingers, and all parts of body away from openings and moving parts.
- Do not pick up anything that is burning or smoking, such as cigarettes, matches, or hot ashes, or any health endangering dusts. Do not use to pick up flammable or combustible liquids such as gasoline or use in areas where they may be present.
- Risk of explosion – Do not spray flammable liquids.
- Use extra care when cleaning on stairs.
- Wear gloves or use rags when removing quick disconnects to prevent burns.
- Liquid ejected at the spray nozzle could be dangerous as a result of its temperature, pressure, or chemical content.
- High pressure jets can be dangerous if subject to misuse. The jet must not be directed at persons, live electrical equipment or the machine itself.
- Do not use the machine within range of persons unless they wear protective clothing.
- Do not direct the jet against yourself or others in order to clean clothes or foot-wear.
- High pressure hoses, fittings and couplings are important for the safety of the machine. Use only hoses, fittings and couplings recommended by the manufacturer.
- To ensure machine safety, use only original spare parts from the manufacturer or approved by the manufacturer.
- Water that has flown through backflow preventers is considered to be non-potable.
- Do not use the machine if a supply cord or important parts of the machine are damaged, e.g. safety devices, high pressure hoses, trigger gun.

GROUNDING INSTRUCTIONS

This appliance must be grounded. If it should electrically malfunction, grounding provides a path of least resistance for electric current to reduce the risk of electric shock. This appliance is equipped with a cord having an equipment-grounding conductor and grounding plug. The plug must be plugged into an appropriate outlet that is properly installed and grounded in accordance with all local codes and ordinances.

 DANGER!

Improper connection of the equipment-grounding conductor can result in a risk of electric shock. Check with a qualified electrician or service person if you are in doubt as to whether the outlet is properly grounded. Do not modify the plug provided with the appliance. If it will not fit the outlet, have a proper outlet installed by a qualified electrician.

Replace the plug if the grounding pin is damaged or broken.

The Green (or Green/Yellow) wire in the cord is the grounding wire. When replacing a plug, this wire must be attached to the grounding pin only.

Extension cords connected to this machine should be 12 gauge, three-wire cords with three-prong plugs and outlets. DO NOT use extension cords more than 50 feet (15 m) long.

 WARNING!

- If an extension cord is used, the plug and socket must be of watertight construction.
- Inadequate extension cords can be dangerous.

KNOW YOUR MACHINE

- 1 Solution Hose Quick Disconnect
- 2 Solution Tank Fill Opening
- 3 Vacuum Hose Barb
- 4 Drain Hose
- 5 Handles
- 6 Roller Balls
- 7 Wheel
- 8 Castor
- 9 Solution Filter
- 10 Recovery Tank Shutoff Float

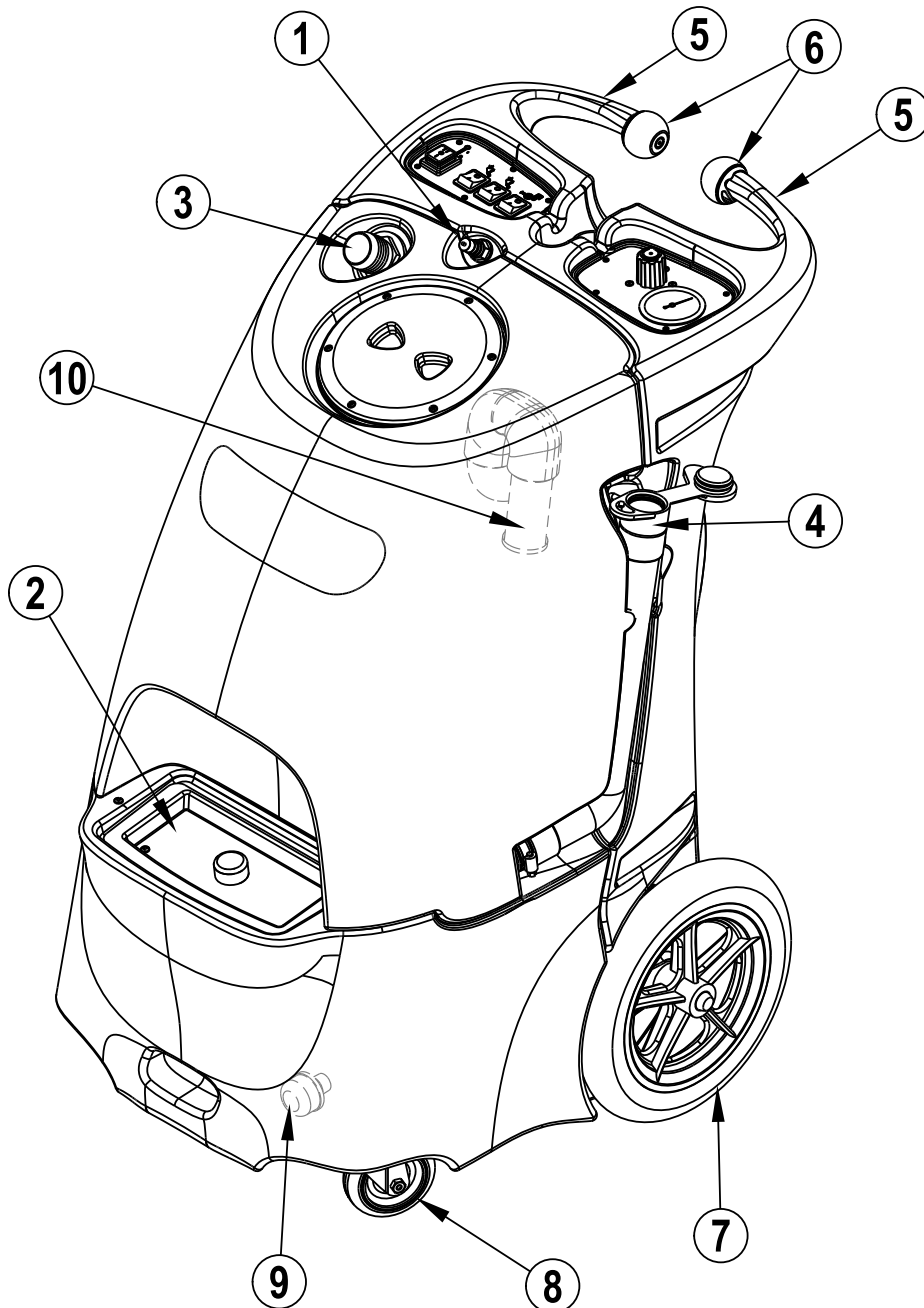

KNOW YOUR MACHINE (CONTINUED)

- 11 Recovery Tank Lid
- 12 Switch Plate
- 13 Wand Storage Clip
- 14 Pressure Adjustment Knob
- 15 Pressure Gauge
- 16 Pressure Relief Valve
- 17 Cord Retainer Straps (four)
- 18 Hour Meter (Optional)
- 19 Wand Retainer Bracket
- 20 Pigtail Power Cords
- 21 Hose Hangers (two)

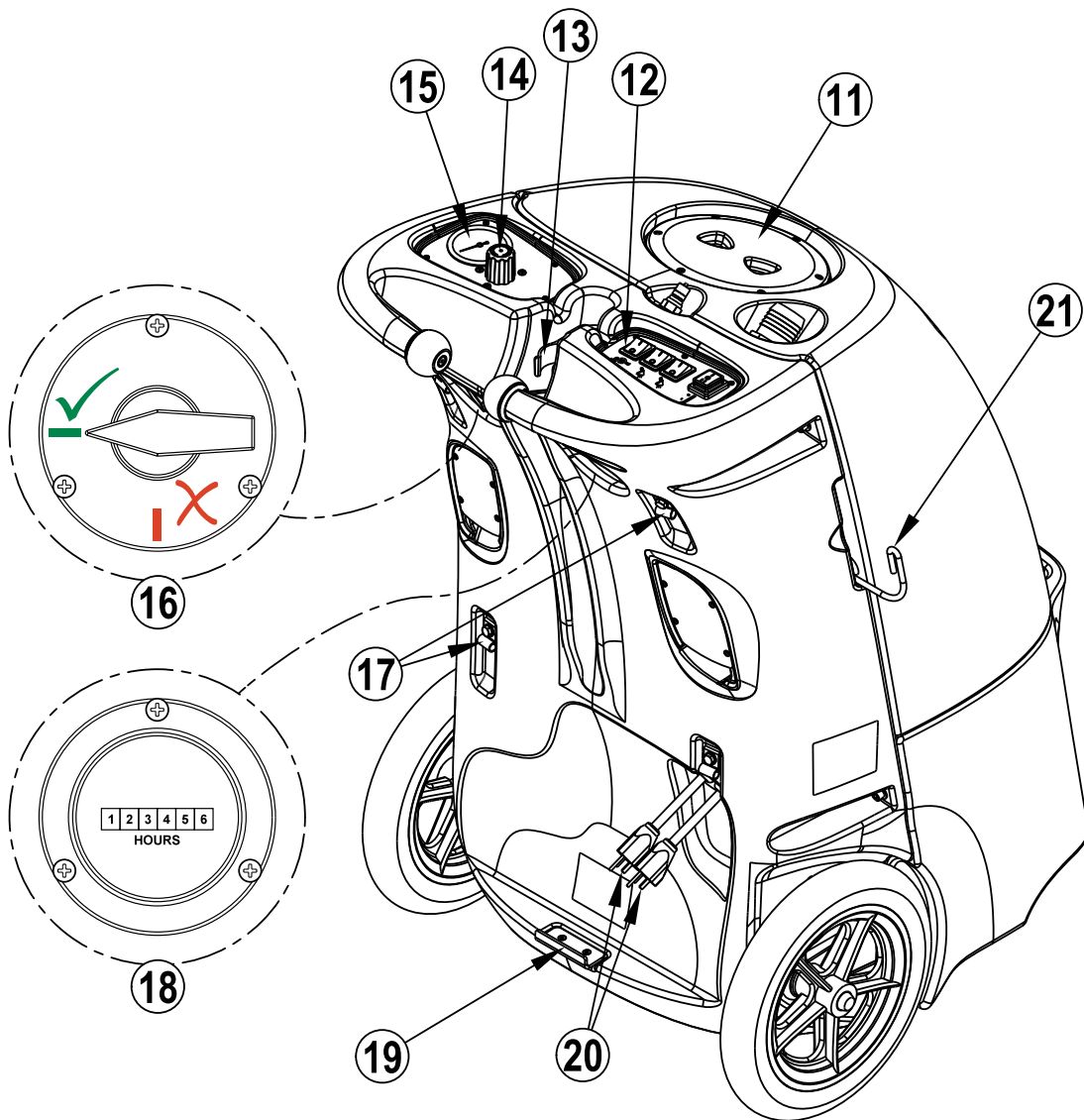

KNOW YOUR SWITCH PLATE

- A **Solution Pump Switch** - This switch turns the solution pump ON and OFF.
- B **Vacuum Switch** - This switch turns the first of the two vacuum motors ON and OFF.
- C **Vacuum Switch** - This switch turns the second of the two vacuum motors ON and OFF.
- D **Heat Switch** - This three position switch controls the water temperature. Position (I) is low temperature, Position (O) is OFF and Position (II) is high temperature.

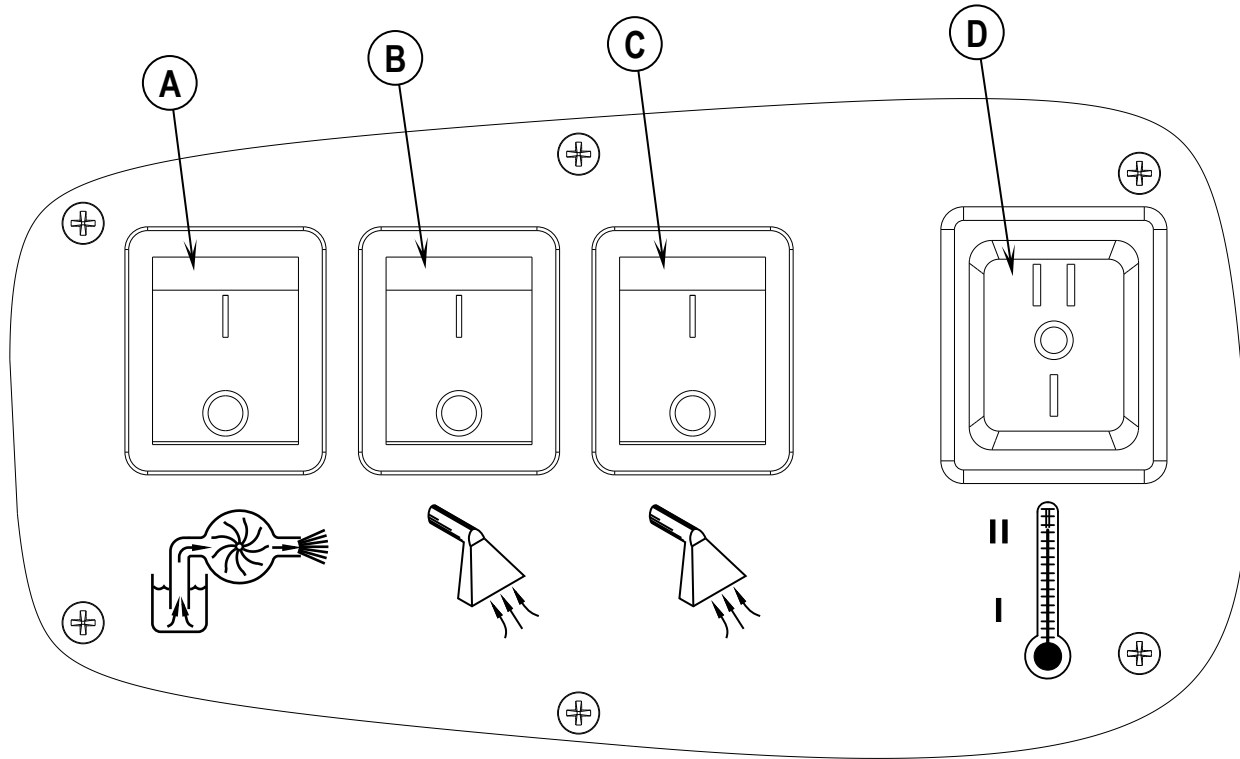

PREPARING THE MACHINE FOR USE

- 1 Inspect the machine, hoses, and cleaning tools for cleanliness and completeness.
- 2 Screw the Recovery Tank Lid (11) closed. Ensure the drain cap is closed tightly.
- 3 Pre-spray spots and heavy traffic areas before extracting with the detergent of your choice. Mix the pre-spray according to the detergent manufacturer's directions.
- 4 Fill the solution tank with clear water (12 gal. / 45.5 L capacity). If desired, add a detergent or rinse of your choice (we recommend a CRI approved detergent). If you choose to add a detergent to the solution tank, be sure to mix well, and always follow the use & dilution instructions on the detergent label. Only use a detergent with a pH between 5 and 10. Although this machine is designed to supply instant hot water, the addition of warm water to the solution tank would increase heater efficiency. Never use water above 130° F/54° C in the solution tank.

**CAUTION!**

Use low-sudsing, liquid detergents designed for carpet extraction.

OPERATING THE MACHINE

- 1 Follow the instructions in the *Preparing the Machine for Use* section of this manual.
- 2 Turn off all the switches. Plug the power cords into properly grounded outlets. Do not connect both cords to the same outlet.
- 3 Attach the priming hose to the machine and place the open end into the solution tank.
- 4 Turn ON the solution pump (A) and let it run until the pump is fully primed (approximately 30 seconds to 1 minute). Once the pump is primed, turn off the pump and remove the priming hose.
- 5 Connect a solution line to the Solution Hose Quick Disconnect (1). Attach the other end of the solution line to the cleaning tool.
NOTE: If there is pressure built up in the solution lines, it may be difficult to connect a solution line to the Quick Disconnect (1). If this is the case place the Pump Switch (A) into the OFF (O) position. Momentarily turn the Pressure Relief Valve (16) from the green "checkmark" position to the red "X" position and back again to the green "checkmark" position, this will relieve the pressure to allow a solution line to be connected to the quick disconnect port.

CAUTION!

Always operate the machine with the Pressure Relief Valve in the Green "checkmark" position to avoid possible damage.

- 6 Connect a vacuum hose to the Vacuum Hose Barb (3). Attach the other end of the vacuum hose to the cleaning tool.
- 7 To use heated water for cleaning, press the Heat Switch (D) into either the Low Temperature position (I) or the High Temperature position (II). Wait two minutes for the heat exchanger to reach temperature.
- 8 Press the Pump Switch (A) to ON (I).
- 9 Press the Vacuum Switches (B & C) to ON (I). The machine can be used with only one vacuum motor running for less suction i.e. cleaning upholstery.
- 10 Spray through your tool a few times to fill the lines with solution. Begin cleaning.
- 11 To adjust the solution spray pressure; rotate the Pressure Adjustment Knob (14) clockwise to increase pressure and counterclockwise to decrease pressure. The pump spraying pressure will be observable at the Pressure Gauge (15) while spraying. Make sure the cleaning tool is spraying when adjusting the pressure, otherwise the pressure reading will be inaccurate.
- 12 Watch the fluid entering the Recovery Tank Lid (11). If there is a large amount of suds in the recovery tank, add a defoamer chemical to the recovery tank.

CAUTION!

- Empty the recovery tank before the fluid or foam enters the vacuum motor.
- If foam or liquid escapes from the machine, switch off immediately.

CAUTION!

Always make sure the float is clean and travels freely before turning on the machine. A float that is stuck will cause the vacuum motor to suck in water, resulting in vac motor damage.

- 13 The recovery tank has a Recovery Tank Shutoff Float (10) to block the vacuum system when the recovery tank is full. You can tell when the float closes by the sudden change in the sound of the vacuum motor. When the float closes, the recovery tank must be emptied. The machine can continue to dispense solution, but **will not** pick up water with the float closed.
- 14 Monitor the water level in the solution tank. Do not let the pump run dry. When the solution tank gets low, turn off the pump and the vacuum motor(s), refill the solution tank with water and the proper ratio of cleaning detergent. Empty the recovery tank and continue cleaning.
- 15 When the operator has completed the job; vacuum all unused solution from the solution tank into the recovery tank, turn off the pump, vacuum motor(s) and heat exchanger. Unplug the machine.
- 16 Push the machine to a designated waste water "DISPOSAL SITE" and empty the recovery tank. To empty, loosen the Velcro strap retaining the Recovery Tank Drain Hose (4) into its side storage location, then remove the plug (hold the end of the hose above the water level in the tank to avoid sudden, uncontrolled flow of waste water).
- 17 Follow the instructions in the *After Using the Machine* section of this manual.

OPERATING THE MACHINE

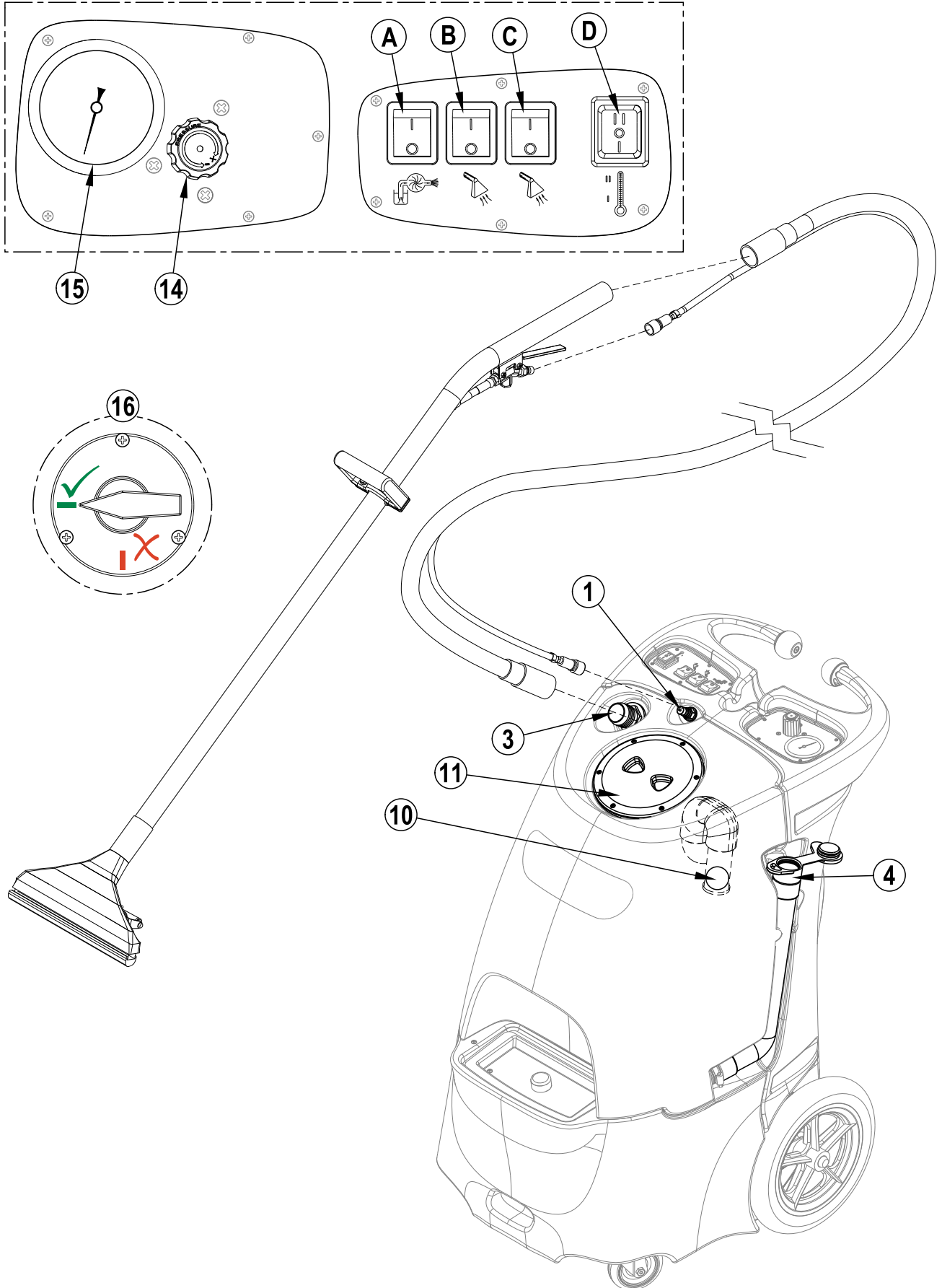

AFTER USING THE MACHINE

- 1 To empty the solution tank, open Solution Tank Fill Opening (2) and vacuum out all unused solution into the recovery tank using the vacuum hose. Rinse the tank with clean water.
- 2 Turn all the Power Switches (A, B, C & D) to OFF (O). Unplug the Power Cords (20). Coil the cords and secure them to the rear of the machine using the four Cord Retainer Straps (17).
- 3 To empty the recovery tank, loosen the Velcro strap retaining the Recovery Tank Drain Hose (4) into its side storage location. Direct the hose to a designated waste water "DISPOSAL SITE" and remove the plug (hold the end of the hose above the water level in the tank to avoid sudden, uncontrolled flow of waste water). Rinse the tank with clean water. Inspect the drain hose; replace if kinked or damaged.
- 4 Disconnect the solution and vacuum hoses from the machine, at the Solution Hose Quick Disconnect (1) and Vacuum Hose Barb (3) respectively. Flush the vacuum hose with warm water to wash any debris out of the vacuum hose and cleaning tool. Inspect them for damage. Fold down the Hose Hangers (21) and the hoses can be wrapped around the machine for storage. Set the wand on the Wand Retainer Bracket (19) and secure to the back of the machine at the Wand Storage Clip (13).
- 5 Wipe the machine with a damp cloth. Do not use abrasive chemicals or solvents.
- 6 Perform any required maintenance before storage.

MAINTENANCE SCHEDULE

MAINTENANCE ITEM	Daily	Weekly	Yearly
Check / Clean Tanks & Hoses	•		
Check / Clean Recovery Tank Shut-Off Float	•		
Clean Extraction Wand/Tool	•		
Inspect & Clean Solution Filter		•	
*Check Carbon Brushes			•

* Have a HydraMaster service technician check the vacuum motor carbon brushes once a year or after 300 operating hours. Check the pump motor carbon brushes every 500 hours or once a year.

IMPORTANT!

Motor damage resulting from failure to service the carbon brushes is not covered under warranty. See the Limited Warranty Statement.

- 7 Store the machine indoors in a clean, dry place with the recovery tank lid open. Keep from freezing.

POWER CORD MAINTENANCE

Once a week (or more often if necessary), check the power cords for cracked or damaged insulation, exposed wires in the cord or plug, and damaged or missing ground pin. Repair or replace damaged cord or plug **immediately**.

TROUBLESHOOTING:

<u>IF THIS OCCURS</u>	<u>CHECK THIS</u>
NO SPRAY	Solution tank is empty, or filter is plugged. Clogged spray tip(s). Pump not running or not primed. Valve on wand not operating. Solution hose not completely connected to hose or to machine.
LOW PUMP PRESSURE	Check to see that the pressure relief valve is fully seated in the green checkmark "operating" position (500 models only).
PUMP DOES NOT RUN	This pump motor runs on AC voltage, so it should start running as soon as you turn on the switch. If the pump motor does not start running, check the wiring to the switch and to the motor. Check the switch to see if it is "open".
LOW SUCTION	Debris is plugging cleaning tool or vacuum hose. Drain hose cap is not completely closed. Recovery tank lid is not seated or gasket is damaged.
NO SUCTION	Ball in the float is blocking air flow. Turn off the vacuum so the ball will drop down, or the recovery tank is full and needs to be emptied. No power to motor(s). Test the switches. Test the vacuum motors.
LOW HEAT	Spraying too long. Try spraying for 12-15 seconds, or about three strokes. Heat exchanger needs to be flushed. Wrong tool being used. Too much water passing through. Longer hose or larger diameter hose, than standard.
NO HEAT	Heat is not turned on. No power in the wall outlet - check to see if the breaker has tripped. Call your distributor for additional help.

TECHNICAL SPECIFICATIONS (as installed and tested on the unit)

Model	PEX™ 500-C-TICK
Model No.	56384886
Voltage/frequency	230 V / 50 Hz
Rated Current	15 Amp
Protection Class (electrical)	Class 1
Protection Grade	IPX4
Sound Pressure Level (IEC 60704-2-1)	68.7 dB LpA, 3 dB KpA
Total Weight	112 lbs. (50.8 kg)
Solution Tank Capacity	12 gal (45.5 L)
Recovery Tank Capacity	10 gal (37.8 L)

TABLE OF CONTENTS

DESCRIPTION	PAGE
Decal System.....	16-17
Pallet System 500-1 C-TICK.....	18-19
Pallet System 500-2 C-TICK.....	20-21
Recovery System.....	22
Solution System.....	23
Wiring Diagram.....	24-25
Options & Accessories.....	25
Water Flow Diagram.....	26

WHEN ORDERING PARTS

* Use the part numbers from the "Ref. No." columns in this parts list. If the "Ref. No." column is blank; look under the "Kit" column to identify which kit contains the part in question, then use the kit callout, for example "K1", to find the "Ref. No." for that kit.

Kit	Item	Ref. No.	Qty	Description
K1	1		16	Washer Flat 3/16 Zinc Plat
K1	2		2	Screw-BHS-Brass-10-32x3/8-MS
K1	3		3	Washer EPDM 7/32 X 1/8
	4	805	1	Chain-Cover
	5	905	2	Caster Swivel 4 Gray Non MA
K1	6		2	Nut, Hex Nyl Loc 10-24
K1	7		3	Scr- Hex SS 1/4-20 X .75
K1	8		16	Scr, Hex Hd Loc 1/4-20 x .50
K1	9		3	Wsh, Fit SS .260 X 1.000 X .074
	10	56113012	1	Solution Tank
	11	56113034	2	Hinge Plate
K1		56113103	1	Kit-Hardware Solution Tank

* Specify the model and serial number of the machine.

* Use the space below to record the model and serial number for future reference.

Model _____ Serial No. _____

DECAL SYSTEM C-TICK

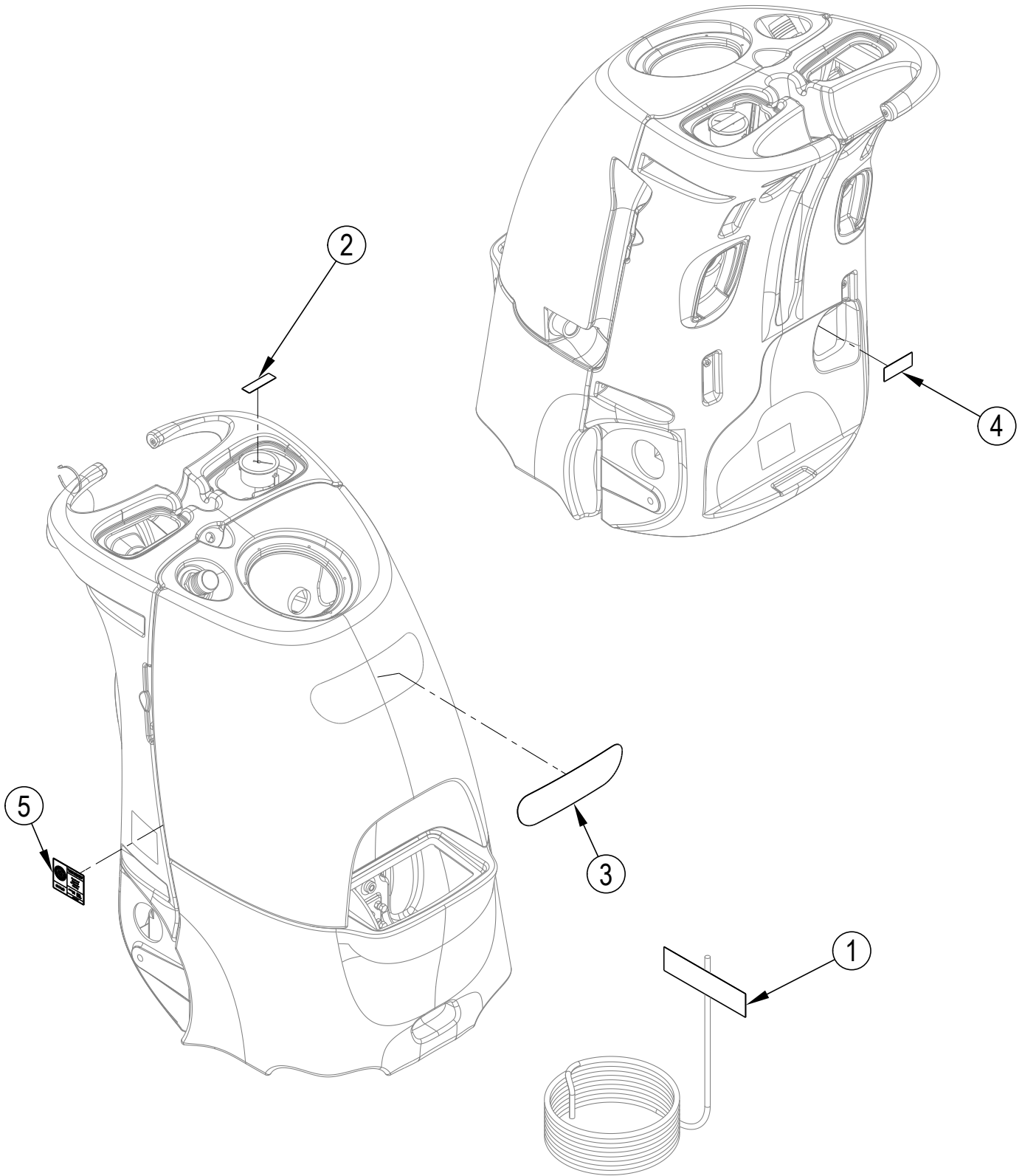

DECAL SYSTEM C-TICK

Kit	Item	Ref. No.	Qty	Description
	1	4339	2	Label Caution / Extension Cord
	2	4344	1	Label Gauge Priming Warning 2
	3	56384917	1	Decal-PEX 500
	4	56380692	1	Label Danger Electric Shock
	5	56380831	1	Decal-CRI Gold

PALLET SYSTEM 500-1 C-TICK

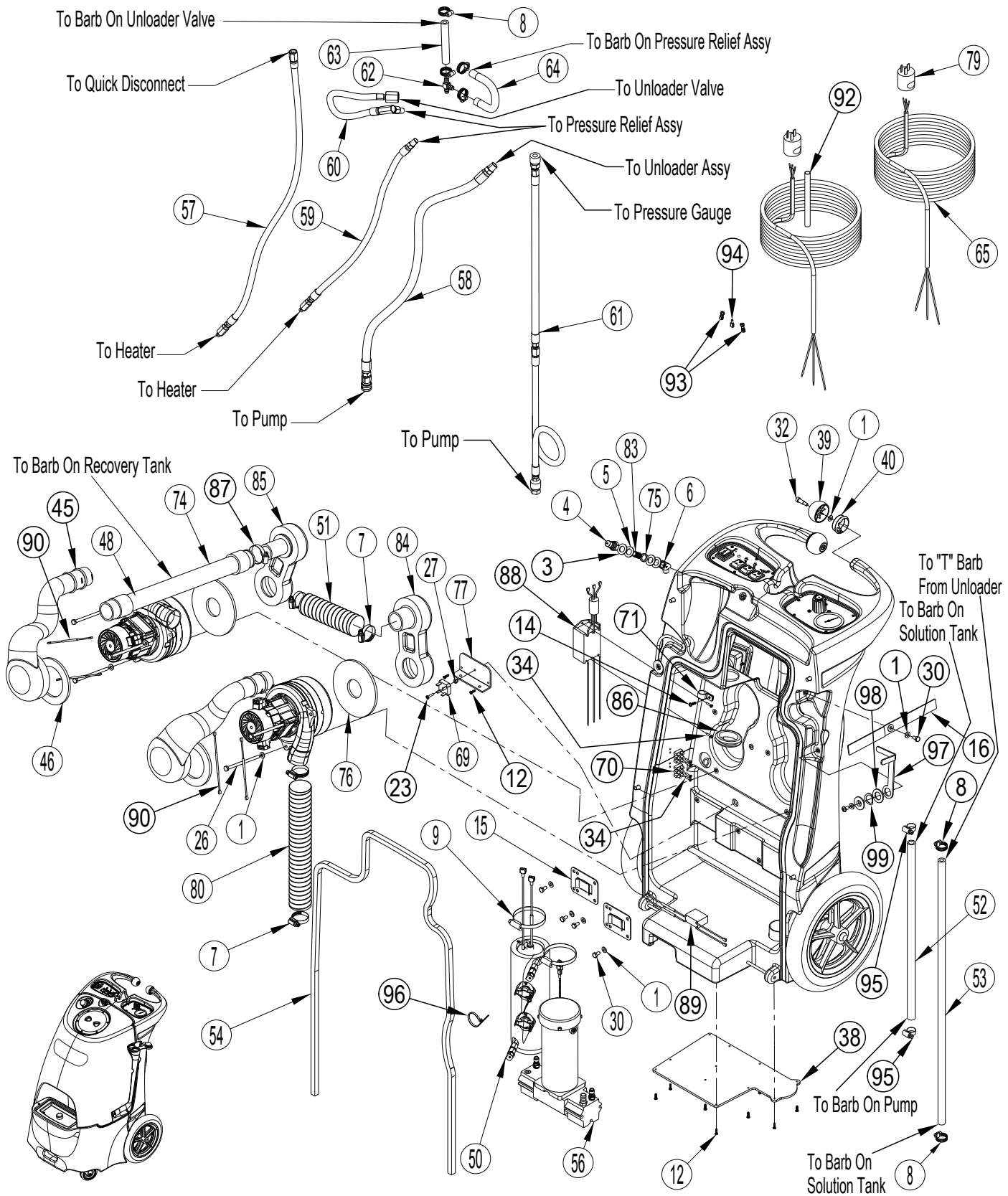

PALLET SYSTEM 500-1 C-TICK

Kit	Item	Ref. No.	Qty	Description	Kit	Item	Ref. No.	Qty	Description
K1	1		20	Washer Flat 3/16 Zinc Plat		55	56113073	1	Switchplate Assy 230v
K1	2		11	Screw-Php-SS-4x3/8-Sms		56	56113075	1	240v-500psi Pump Assy
	3	31USP	1	Washer Brass Half Hard 1 X		*	56113117	1	Kit-Pump Head 500 PSI Complete (Pump w/fittings & Bearing & Cam Assy)
	4	45USP	1	Quick Disconnect Plug Male		*	56113102	1	Kit-Pump Motor 240V (Motor w/Bearing & Cam Assembly)
	5	115USP	3	Washer 1 OD X 9/16 Id X		57	56113077	1	Hose-1/4" Id 1/8mnpt 1/4 Fnpt
	6	140USP	1	Elbow 45deg.Angle 1/4 Male X 1		58	56113078	1	Hose-3/8 Id 1/4qd 3/8mnpt
	7	156USP	4	Hose Clamp-Size 28-1-9/16- 2 1/2		59	56113079	1	Hose-1/4 Id 1/8mnpt 1/4 Fnpt
	8	50248A	6	Clamp. Hose		60	56113080	1	Hose-1/4id 3/8 Fnpt 90-1/4mnpt
	9	198USP	2	Hose Clamp 48 3-1/2dia 9		61	56113110	1	Hose-Assy
	10	219USP	1	Quick Connect Brass 1/4 FPT		62	56113085	1	Union Tee-Barb 3/8id Hose
	11	230USP	2	Retainer Power Cord Water T		63	56113086	1	Hose-3/8 Id
K1	12		24	Screw-Php-SS-6x1/2-Sms		64	56113087	1	Hose-3/8 Id
K1	13		6	Screw-Fhp-SS-2x1/4-Sms		65	56113089	2	Power Cord
K1	14		4	Screw-Ph-Combo-Tapping-8x5/8 AB		66	56113093	2	Hose Hanger Bushing
	15	455USP	2	Mount Heat Exchanger		67	56113104	1	Pressure Relief Assembly
	16	1130	2	Strap-Velcro-1.0 X 11-Black-Hook		68	56113105	1	Unloader Assembly
	17	1554	1	Mount-Plate-Valve		69	56265103	1	Rectifier. 35 Amp
	18	1555	1	Clamp-Valve-Mount		70	56183523	2	Terminal Block
	19	1603	4	Strap-Buckle/Cord-W/Spur Grommet		71	56442003	1	Clamp-P
	20	1644	3	Switch Rocker Dpst On/Off 20		72	56003873	2	Nut-Hex Flange SS M4-0.7
	21	2092	2	Wheel 12"X1" Black On Gray 1/2" Axle		73	56900000	1	Plug. Cap
	22	2165	1	Gage-Pressure		74	56113127	1	Vacuum Hose
K1	23		1	Scr-Pan Phil 8-32 X .75		75	116A	1	Bushing 3/4 X 9/16
K1	24		4	Wsh. Flt Sae 5/16		76	2013A	2	Gasket 1 Side Adhesive 5 1/2
K1	25		2	Scr. Soc Hd 1/4-20 X 1.00		77	2025A	1	Heat Sink Plate Bridge Rectifier
K1	26		6	Scr. Hex 1/4-20 X 4.25		78	27AUSP	2	Axel Cap Black Pal Nut
K1	27		1	Nut. Hex Nyl Loc 8-32		79	298B	2	Electrical Plug Australian & N
K1	28		2	Scr. Pan Phil Loc 1/4-20 X .62		80	430A	1	Vac Hose 2" ID X 13.5 Black Rubber
K1	29		3	Scr. Pan Phil SS 8-32 X .50		81	910-2450	1	Axel Rod Zinc Plate 1/2 OD
K1	30		9	Scr. Hex Hd Loc 1/4-20x.50		82	928B	2	Louver 3 Black Plastic
K1	31		4	Scr. Soc Hd 5/16-18 X 1.25 Zinc Plated		83	92AUSP	1	Nipple-SS-1/4 Pipe-Length .90
K1	32		2	Scr-Soc Shd SS Loc .31 X .625 X 1/4-20		84	MA-6	1	Manifold for Cobra Black
K1	33		2	Scr-Flt Phil Sm #8 X .50		85	SUBMA-6	1	Manifold Black w/1063 S-W
K1	34		6	Scr-Pan Phil Sm #6 X .75		86	56056215	1	Grommet
K1	35		1	Scr-Pan Phil 8-32 X .31		87	1518	1	Hose Clamp 3/4 X 1 3/4 SS
	36	56113014	1	Equipment Pallet		88	56113120	1	Filter
	37	56113015	2	Cover-Intake-Pallet		89	56113121	1	Filter
	38	56113016	1	Cover-Exhaust Chamber		90	56113122	4	Choke Assy
	39	56113017	2	Roller Ball-Pallet		91	56113124	1	Gasket Switchplate
	40	56113019	2	Roller Ball Bushing-Pallet		92	912	6	Shrink Tubing 1/2 Red Poly
	41	56113020	1	Wand Clip		93	1118	2	Electrical Connec. 250 X .032
42#	56113021		1	Hose Hanger Ss		94	56900902	1	Rec. 250 16-14 Awg
	43	56113027	1	Cover Plate Pressure 500PSI		95	56219932	2	Clamp-Hose SAE #6
	44	56113029	1	Rocker Switch-3 Position		96	35	1	Tie 4 Black Weather Resis
	45	56113032	2	Vac Motor Intake-3 Stage		97#	56384656	1	Bracket-Hose Clip
	46	56113033	2	Gasket Vac Intake		98#	56004000	1	Wsh-Flt Ss .765x1.312x.090
	47	56113035	1	Wand Bracket		99#	56004001	1	Wsh-Disc Spring Ss .8x1.1x.021
	48	56113040	2	Vac Motor 230V-3 Stage					
	*	56113057	1	Vac Motor Brush Kit-240V					
	49	56113046	1	Harness-Main					
	50	56113059	1	Heat Exch Complete-240v 2000w					
	*	56113109	1	Kit-Heater Repair PEX					
	51	56113135	1	Vac Hose Rubber 7.75 X 2.0 ID					
	52	56412277	1	Solution Hose					
	53	56113063	1	Hose 3/8 ID					
	54	56113064	1	Gasket-Pallet					

Service Kits

K1 56113107 1 Kit-Hardware Pallet Sys 500

[] = Not Shown

* = Optional, Not Included

= Revised or new since last update

PALLET SYSTEM 500-2 C-TICK

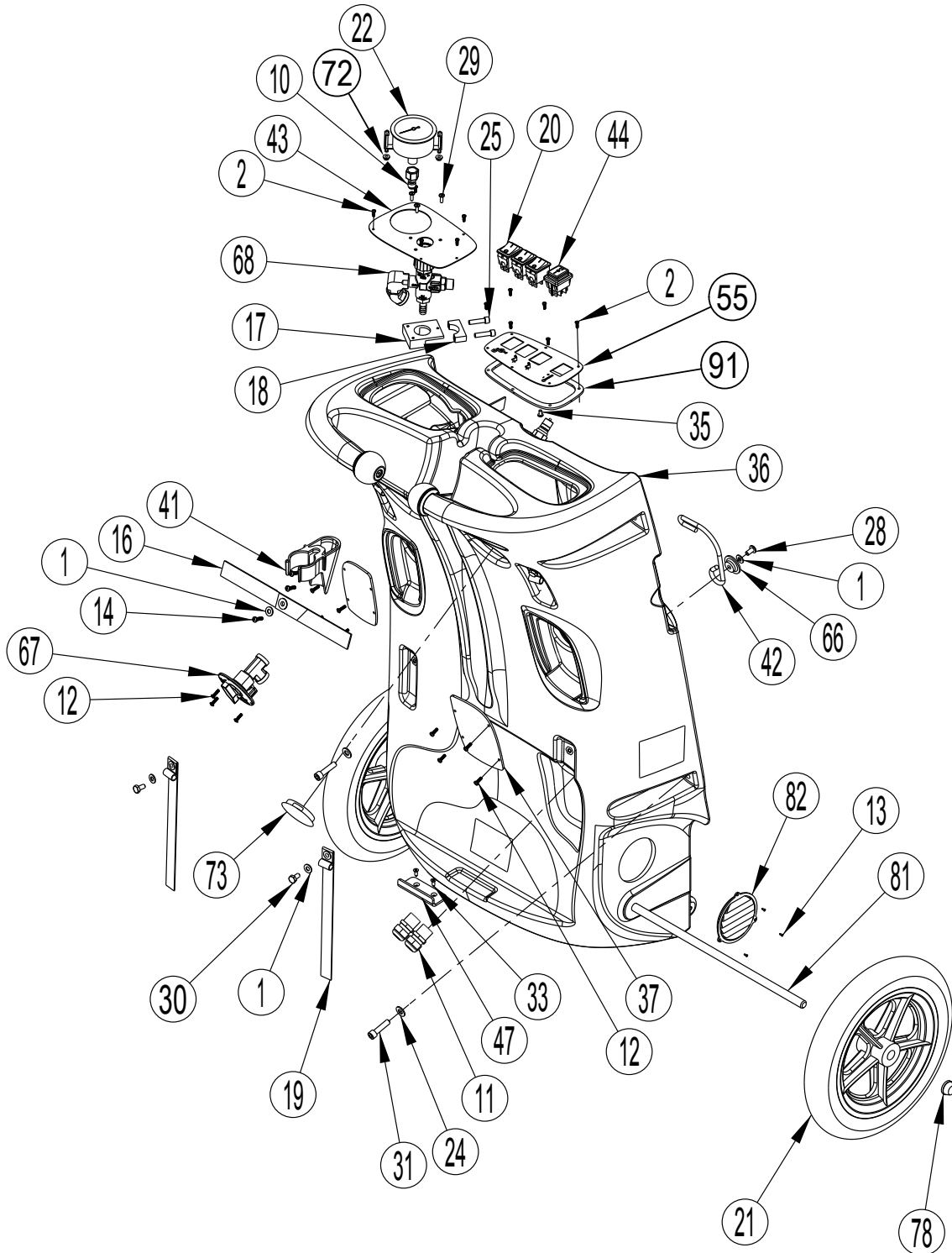

PALLET SYSTEM 500-2 C-TICK

Kit	Item	Ref. No.	Qty	Description	Kit	Item	Ref. No.	Qty	Description
K1	1		20	Washer Flat 3/16 Zinc Plat		55	56113073	1	Switchplate Assy 230v
K1	2		11	Screw-Php-SS-4x3/8-Sms		56	56113075	1	240v-500psi Pump Assy
	3	31USP	1	Washer Brass Half Hard 1 X		*	56113117	1	Kit-Pump Head 500 PSI Complete (Pump w/fittings & Bearing & Cam Assy)
	4	45USP	1	Quick Disconnect Plug Male		*	56113102	1	Kit-Pump Motor 240V (Motor w/Bearing & Cam Assembly)
	5	115USP	3	Washer 1 OD X 9/16 Id X		57	56113077	1	Hose-1/4" Id 1/8mnpt 1/4 Fnpt
	6	140USP	1	Elbow 45deg.Angle 1/4 Male X 1		58	56113078	1	Hose-3/8 Id 1/4qd 3/8mnpt
	7	156USP	4	Hose Clamp-Size 28-1-9/16- 2 1/2		59	56113079	1	Hose-1/4 Id 1/8mnpt 1/4 Fnpt
	8	50248A	6	Clamp, Hose		60	56113080	1	Hose-1/4id 3/8 Fnpt 90-1/4mnpt
	9	198USP	2	Hose Clamp 48 3-1/2dia 9		61	56113110	1	Hose-Assy
	10	219USP	1	Quick Connect Brass 1/4 FPT		62	56113085	1	Union Tee-Barb 3/8id Hose
	11	230USP	2	Retainer Power Cord Water T		63	56113086	1	Hose-3/8 Id
K1	12		24	Screw-Php-SS-6x1/2-Sms		64	56113087	1	Hose-3/8 Id
K1	13		6	Screw-Fhp-SS-2x1/4-Sms		65	56113089	2	Power Cord
K1	14		4	Screw-Ph-Combo-Tapping-8x5/8 AB		66	56113093	2	Hose Hanger Bushing
	15	455USP	2	Mount Heat Exchanger		67	56113104	1	Pressure Relief Assembly
	16	1130	2	Strap-Velcro-1.0 X 11-Black-Hook		68	56113105	1	Unloader Assembly
	17	1554	1	Mount-Plate-Valve		69	56265103	1	Rectifier, 35 Amp
	18	1555	1	Clamp-Valve-Mount		70	56183523	2	Terminal Block
	19	1603	4	Strap-Buckle/Cord-W/Spur Grommet		71	56442003	1	Clamp-P
	20	1644	3	Switch Rocker Dpst On/Off 20		72	56003873	2	Nut-Hex Flange SS M4-0.7
	21	2092	2	Wheel 12"X1" Black On Gray 1/2" Axle		73	56900000	1	Plug, Cap
	22	2165	1	Gage-Pressure		74	56113127	1	Vacuum Hose
K1	23		1	Scr-Pan Phil 8-32 X .75		75	116A	1	Bushing 3/4 X 9/16
K1	24		4	Wsh, Fit Sae 5/16		76	2013A	2	Gasket 1 Side Adhesive 5 1/2
K1	25		2	Scr, Soc Hd 1/4-20 X 1.00		77	2025A	1	Heat Sink Plate Bridge Rectifier
K1	26		6	Scr, Hex 1/4-20 X 4.25		78	27AUSP	2	Axel Cap Black Pal Nut
K1	27		1	Nut, Hex Nyl Loc 8-32		79	298B	2	Electrical Plug Australian & N
K1	28		2	Scr, Pan Phil Loc 1/4-20 X .62		80	430A	1	Vac Hose 2" ID X 13.5 Black Rubber
K1	29		3	Scr, Pan Phil SS 8-32 X .50		81	910-2450	1	Axel Rod Zinc Plate 1/2 OD
K1	30		9	Scr, Hex Hd Loc 1/4-20x.50		82	928B	2	Louver 3 Black Plastic
K1	31		4	Scr, Soc Hd 5/16-18 X 1.25 Zinc Plated		83	92AUSP	1	Nipple-SS-1/4 Pipe-Length .90
K1	32		2	Scr-Soc Shd SS Loc .31 X .625 X 1/4-20		84	MA-6	1	Manifold for Cobra Black
K1	33		2	Scr-Fit Phil Sm #8 X .50		85	SUBMA-6	1	Manifold Black w/1063 S-W
K1	34		6	Scr-Pan Phil Sm #6 X .75		86	56056215	1	Grommet
K1	35		1	Scr-Pan Phil 8-32 X .31		87	1518	1	Hose Clamp 3/4 X 1 3/4 SS
	36	56113014	1	Equipment Pallet		88	56113120	1	Filter
	37	56113015	2	Cover-Intake-Pallet		89	56113121	1	Filter
	38	56113016	1	Cover-Exhaust Chamber		90	56113122	4	Choke Assy
	39	56113017	2	Roller Ball-Pallet		91	56113124	1	Gasket Switchplate
	40	56113019	2	Roller Ball Bushing-Pallet		92	912	6	Shrink Tubing 1/2 Red Poly
	41	56113020	1	Wand Clip		93	1118	2	Electrical Connec .250 X .032
	42#	56113021	1	Hose Hanger Ss		94	56900902	1	Rec .250 16-14 Awg
	43	56113027	1	Cover Plate Pressure 500PSI		95	56219932	2	Clamp-Hose SAE #6
	44	56113029	1	Rocker Switch-3 Position		96	35	1	Tie 4 Black Weather Resis
	45	56113032	2	Vac Motor Intake-3 Stage		97#	56384656	1	Bracket-Hose Clip
	46	56113033	2	Gasket Vac Intake		98#	56004000	1	Wsh-Fit Ss .765x1.312x.090
	47	56113035	1	Wand Bracket		99#	56004001	1	Wsh-Disc Spring Ss .8x1.1x.021
	48	56113040	2	Vac Motor 230V-3 Stage		Service Kits			
	*	56113057	1	Vac Motor Brush Kit-240V	K1	56113107	1	Kit-Hardware Pallet Sys 500	
	49	56113046	1	Harness-Main		[] = Not Shown			
	50	56113059	1	Heat Exch Complete-240v 2000w		* = Optional, Not Included			
	*	56113109	1	Kit-Heater Repair PEX		# = Revised or new since last update			
	51	56113135	1	Vac Hose Rubber 7.75 X 2.0 ID					
	52	56412277	1	Solution Hose					
	53	56113063	1	Hose 3/8 ID					
	54	56113064	1	Gasket-Pallet					

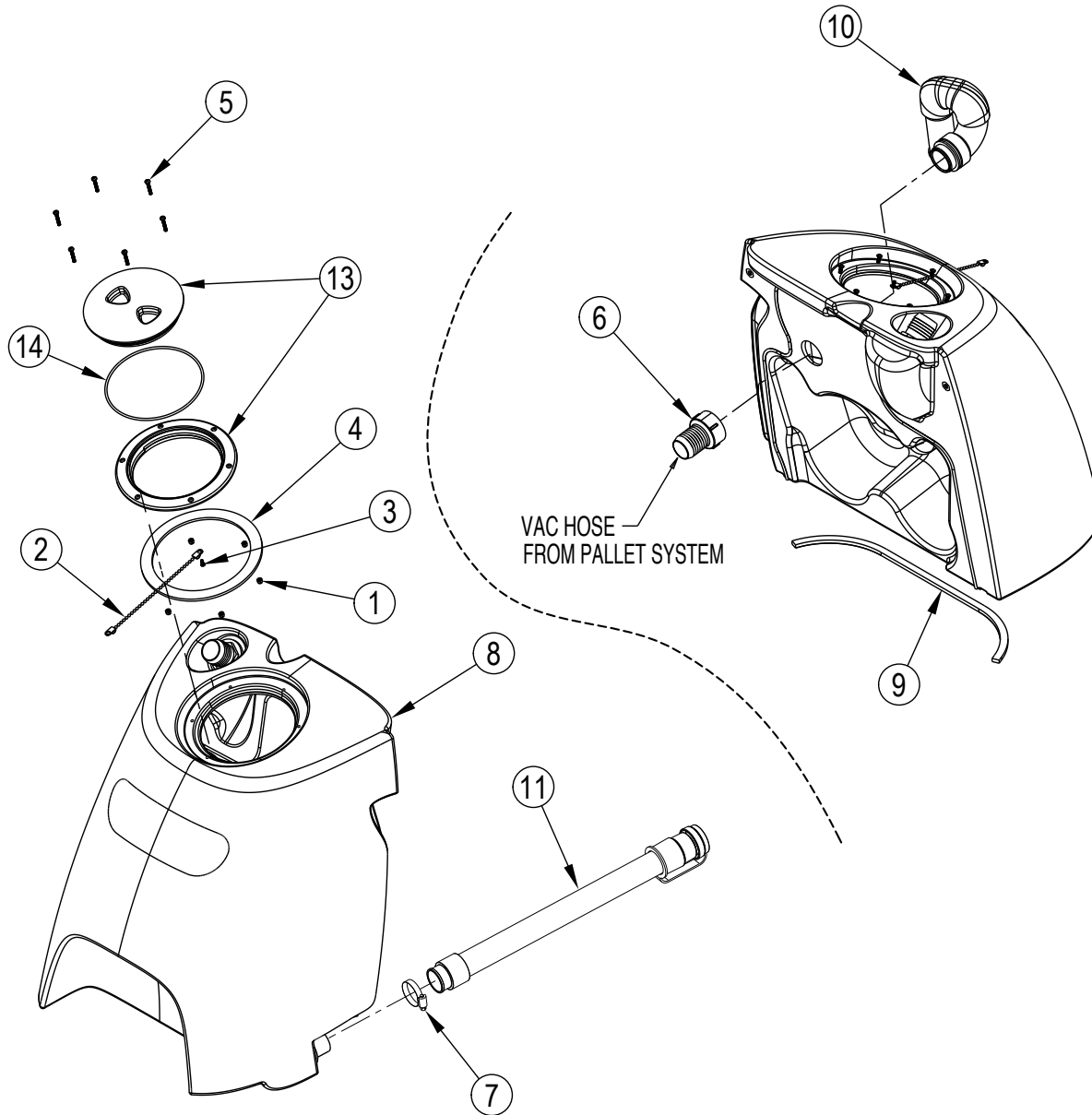

RECOVERY SYSTEM

Kit	Item	Ref. No.	Qty	Description
K1	1		6	Nut-Nylon Lock-SS-8-32
K1	2		1	Chain-Cover
K1	3		1	Screw 6x3/8 S/S Trusshead P
K1	4		1	Gasket-Lid-XLPE-6.5IDx3/16 Thick
K1	5		6	Screw-Php-SS-8-32x1-1/8
	6	1277	1	Barb 1-1/2 X FIPT ABS
	7	1518	1	Hose Clamp 3/4 X 1 3/4 SS
	8	56113158	1	Recovery Tank
	9	56113036	1	Recovery Tank Gasket
	10	56113039	1	Ball Float Assy
	11#	56105265	1	Drain Hose
		56105266	1	Cap-Drain Hose (for 56105265)
K1	13		1	Lid and Ring 6 Lid W/Clear
K1	14	56383436	1	O-Ring

= Revised or new since last update

Service Kits

K1	56113100	1	Kit-Recovery Tank Lid
----	----------	---	-----------------------

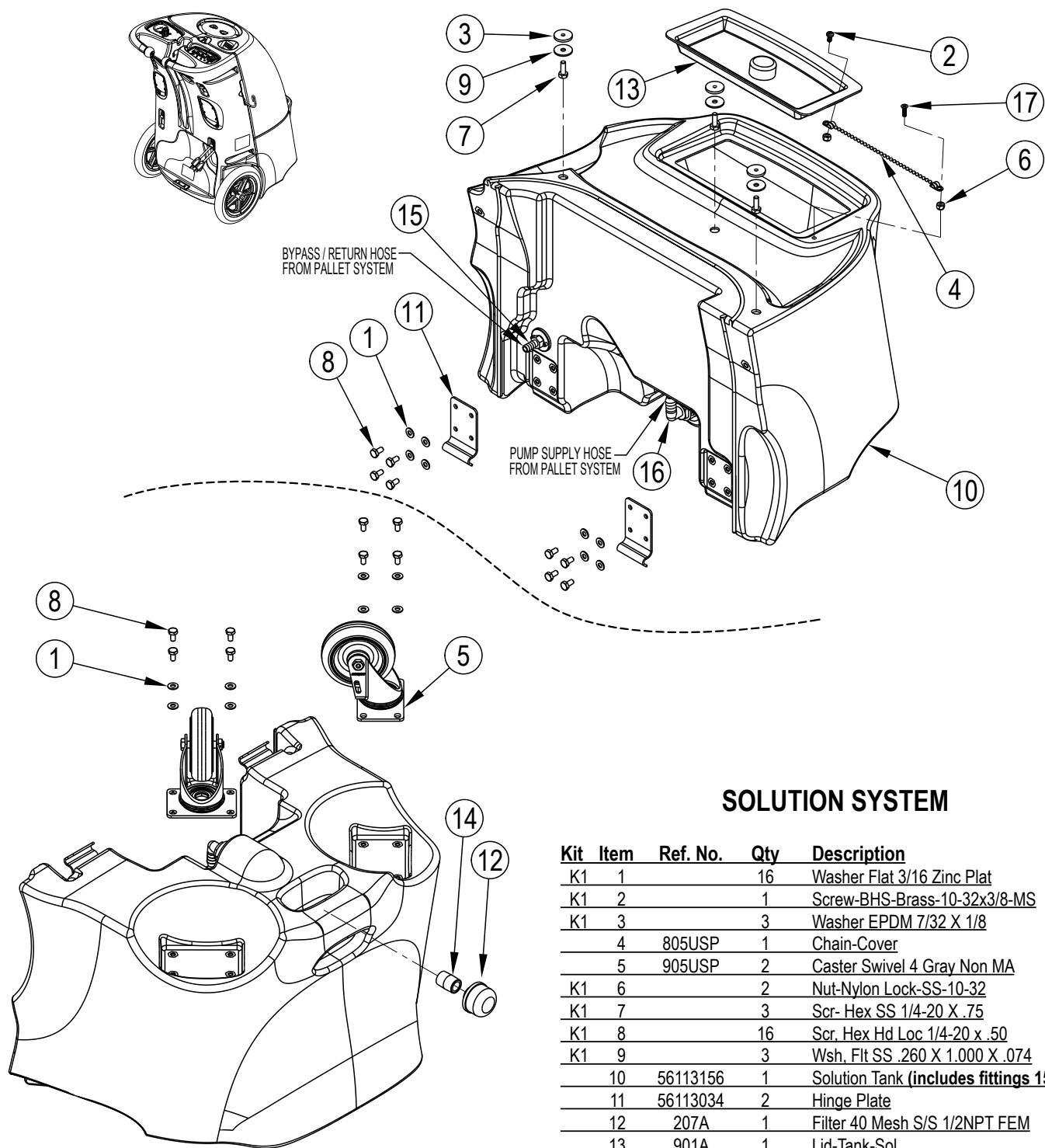

SOLUTION SYSTEM

Kit	Item	Ref. No.	Qty	Description
K1	1	16	16	Washer Flat 3/16 Zinc Plat
K1	2		1	Screw-BHS-Brass-10-32x3/8-MS
K1	3		3	Washer EPDM 7/32 X 1/8
	4	805USP	1	Chain-Cover
	5	905USP	2	Caster Swivel 4 Gray Non MA
K1	6		2	Nut-Nylon Lock-SS-10-32
K1	7		3	Scr- Hex SS 1/4-20 X .75
K1	8		16	Scr. Hex Hd Loc 1/4-20 x .50
K1	9		3	Wsh, Flt SS .260 X 1.000 X .074
	10	56113156	1	Solution Tank (includes fittings 15 & 16)
	11	56113034	2	Hinge Plate
	12	207A	1	Filter 40 Mesh S/S 1/2NPT FEM
	13	901A	1	Lid-Tank-Sol
	14	92BUSP	1	Nipple PVC 1/2 N.P.T.
	15	1083	1	Hose Barb, 3/8 Barb X 1/4 Mpt
	16	1113	1	Hose Barb 90 Degree 1/2 Hos
K1	17		1	FHP-10-32 5-8

Service Kits

K1	56113103	1	Kit-Hardware Solution Tank
----	----------	---	----------------------------

WIRING DIAGRAM

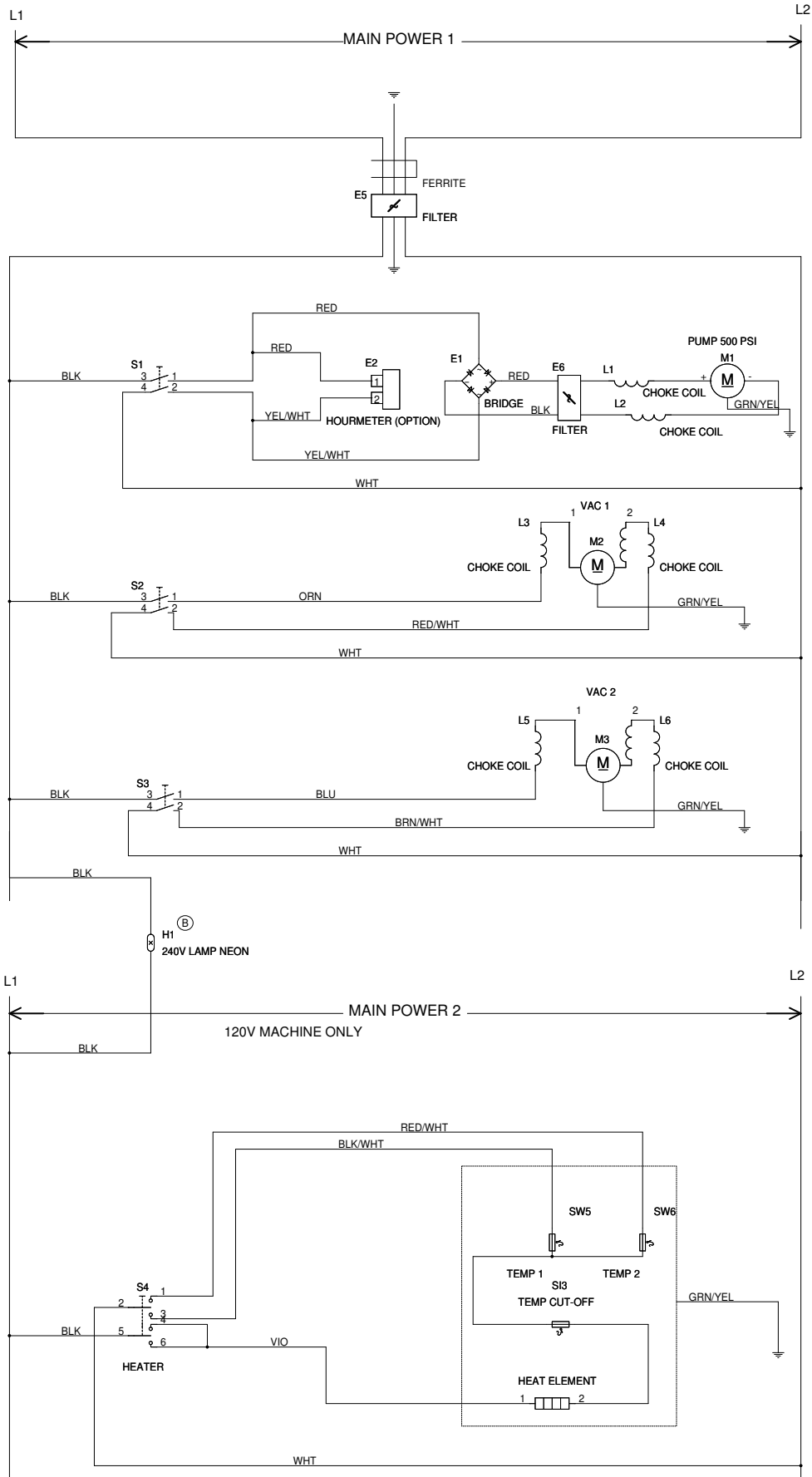

WIRING DIAGRAM

Kit	Item	Ref. No.	Qty	Description
	E1	56265103	1	Rectifier, 35 Amp
	E2	56113108	1	Kit-Hour Meter (Optional)
	E5	56113120	1	Filter
	E6	56113121	1	Filter
	L1	NA	1	Choke Assy
	L2	NA	1	Choke Assy
	L3	56113122	1	Choke Assy
	L4	56113122	1	Choke Assy
	L5	56113122	1	Choke Assy
	L6	56113122	1	Choke Assy
	M1	56113102	1	Kit-Pump Motor 240V
	M2	56113040	2	Vac Motor 230V-3 Stage
	*	56113057	1	Vac Motor Brush Kit-240V
	M3	56113040	2	Vac Motor 230V-3 Stage
	*	56113057	1	Vac Motor Brush Kit-240V
	S1	1644	1	Switch, Pump
	S2	1644	1	Switch, Vac
	S3	1644	1	Switch, Vac
	S4	56113029	1	Switch, Heater
K1	SW5	399	1	Thermostat
K1	SW6	56113030	1	Thermostat
K1	S13	NA	1	Thermal Cutout

Service Kits

K1	56113109	1	Kit-Heater Repair
----	----------	---	-------------------

OPTIONS & ACCESSORIES

Item	Ref. No.	Qty	Description
Options			
*	56113108	1	Kit-Hour Meter
*	FP203	1	Vac Hose/Pressure Ln. 15' Exte
*	FP196	1	Vac Hose/Pressure Ln. 25' Exte
*	000-163-034	1	Evolution Wand 1 1/2" x 13" Head (all models)
*	000-163-220	1	DriMaster 3 Upholstery Cleaning Tool
	SUBSYP1	1	Syphon-Hose-Red (for priming pump)

* = Optional, Not Included

WATER FLOW DIAGRAM

BLUE = FRESH WATER

GREEN = 500PSI WATER FLOW

PURPLE = PRESSURE RELIEF RETURN TO TANK

RED = 500PSI HEATED WATER FLOW

Item	Description
1	Solution Tank
2	Fresh Water Inlet Filter
3	500PSI Pump
4	Unloader Valve
5	Pressure Gauge
6	Pressure Relief Valve
7	500PSI Quick Connect
8	Heater

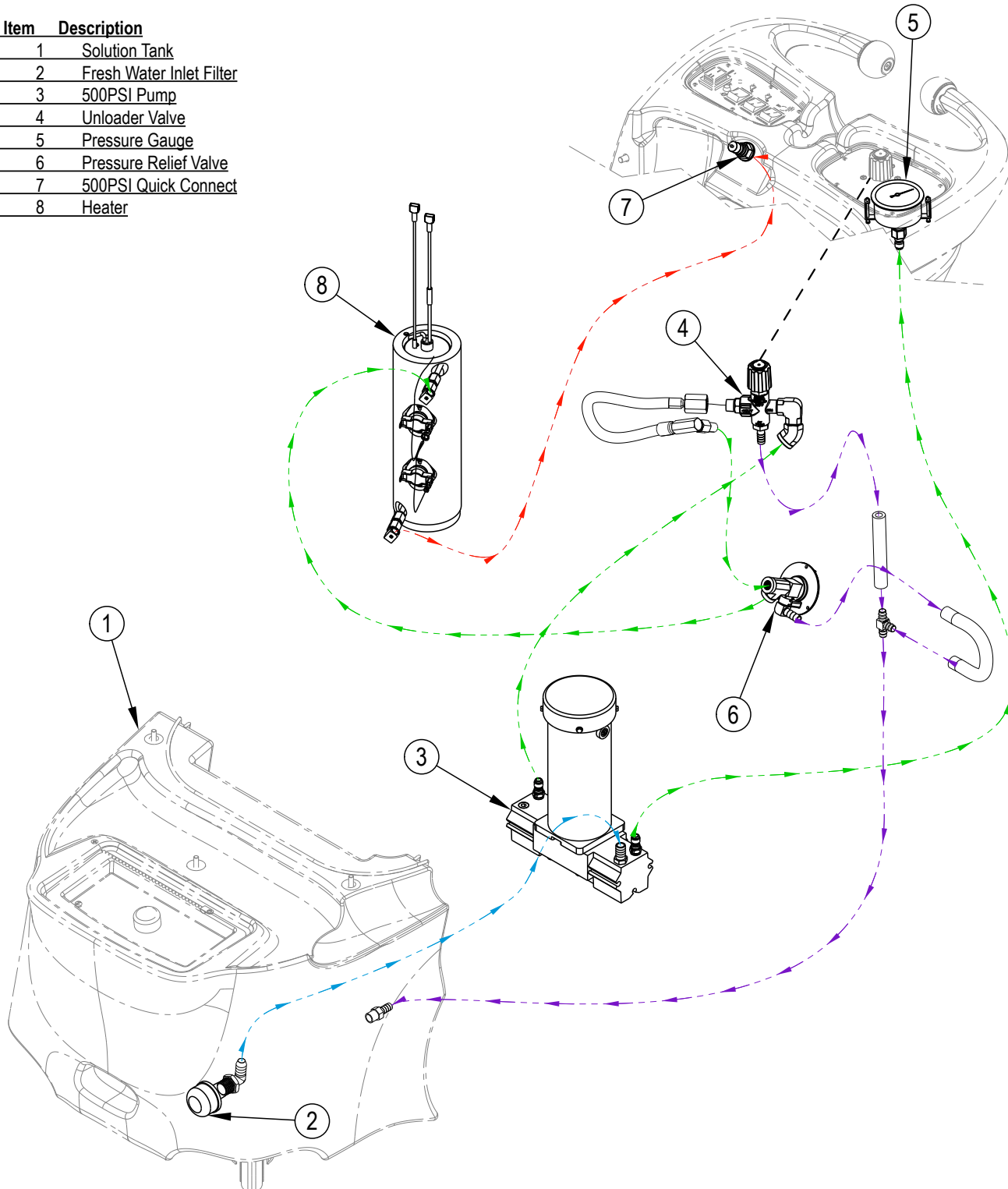



800.426.1301 / 425.775.7272
11015 - 47th Avenue West / Mukilteo, WA 98275
www.hydramaster.com