



# Boxxer 421 Owner's Manual

**HydraMaster**  
11015 47<sup>th</sup> Avenue West  
Mukilteo, Washington 98275

MAN-45049 Rev. 1, September 21, 2012  
(182-065-D)

No part of this manual may be reproduced or used in any form or by any means (i.e. graphic, electronic, photocopying or electronic retrieval systems) without the express written permission of HydraMaster. Specifications and information in this document are subject to change without prior notice. All rights reserved. © 2012 HydraMaster



# Table of Contents

<b>GENERAL INFORMATION.....</b>	<b>SECTION 1</b>
System Concept.....	1-2
Contact Information.....	1-3
Warnings, Cautions and Notices.....	1-4
Responsibilities.....	1-8
Machine Specifications.....	1-11
High Altitude Operation.....	1-13
Local Water Precautions.....	1-13
<b>INSTALLATION INFORMATION.....</b>	<b>SECTION 2</b>
Orientation of Fuel Pump.....	2-4
<b>CLEANING INFORMATION.....</b>	<b>SECTION 3</b>
Precautions.....	3-2
Preparing the Carpet for Extraction.....	3-2
Rinse and Recover.....	3-3
Overwetting.....	3-3
Streaking.....	3-3
Cleaning Tool Tips.....	3-4
<b>OPERATING INSTRUCTIONS.....</b>	<b>SECTION 4</b>
Exhaust Diverter System.....	4-2
Start Up.....	4-5
Carpet or Hard Surface Cleaning.....	4-6
Upholstery Cleaning.....	4-7
Flood Extraction.....	4-8
Shut Down.....	4-9
<b>MACHINE MAINTENANCE.....</b>	<b>SECTION 5</b>
Operational Maintenance.....	5-2
Overall Machine Maintenance.....	5-3
High Pressure Pump.....	5-5
Vacuum System.....	5-9
Freeze Guard.....	5-11
<b>WATER AND CHEMICAL SYSTEM.....</b>	<b>SECTION 6</b>
Water and Chemical Flow Operation.....	6-1
Before Cleaning.....	6-1
Chemical System Maintenance.....	6-2
Troubleshooting.....	6-3



<b>ELECTRICAL SYSTEM.....</b>	<b>SECTION 7</b>
Troubleshooting .....	7-1
<b>SYSTEMS TROUBLESHOOTING .....</b>	<b>SECTION 8</b>
High Pressure Pump .....	8-6
Vacuum .....	8-9
<b>ASSEMBLIES AND PARTS LISTS.....</b>	<b>SECTION 9</b>
Machine Assembly Parts List .....	9-7
Frame Assembly Parts List .....	9-11
Engine Assembly Parts List.....	9-13
Dash Assembly Parts List .....	9-16
Electrical Control Panel Assembly Parts List .....	9-18
Blower Heat Exchanger Assembly Parts List.....	9-19
Water Box Assembly Parts List .....	9-20
Pump Assembly Parts List .....	9-21
Chemical Pump Assembly .....	9-22
Blower Assembly Parts List.....	9-25
Vacuum Relief Valve (Collector Box) Assembly Parts List .....	9-26
Exhaust Assembly Parts List.....	9-28
Diverter Valve Actuator Assembly Parts List .....	9-29
Hi PSI Manifold Assembly Parts List.....	9-31
By-Pass Valve Assembly Parts List.....	9-32
Chemical Jug Tray Assembly Parts List.....	9-33
70 Gallon Universal Recovery Tank Assembly Parts List.....	9-36
70 Gallon Universal Recovery Tank Cover Assembly Parts List .....	9-37
100 Gallon Universal Recovery Tank (URT) Assembly Parts List .....	9-39
100 Gallon Universal Recovery Tank (URT) Cover Assembly Parts List .....	9-40
85 Gallon Rotomolded Tank Assembly Parts List .....	9-43
Hose Routings.....	9-44
<b>HOW TO ORDER PARTS .....</b>	<b>SECTION 10</b>
Warranty Parts Orders .....	10-1
Parts Orders.....	10-1
Emergencies .....	10-1

WARRANTY INFORMATION .....	SECTION 11
Blower .....	11-1
High Pressure Water Pump .....	11-1
Vacuum Recovery Tank .....	11-1
Chemical System .....	11-1
Control Panel .....	11-2
Vacuum and Solution Hoses .....	11-2
Cleaning Wand.....	11-2
Water Heating System .....	11-2
Hard Water Deposits.....	11-2
Warranty Procedure .....	11-2
ACCESSORIES AND CHEMICAL SOLUTIONS.....	SECTION 12

# List of Figures

Figure 1-1. Boxxer 421 with Standard 70 Gallon Recovery Tank.....	1-1
Figure 1-2. Hard Water Map of Mainland United States.....	1-14
Figure 2-1. Roof Vent Positions.....	2-1
Figure 2-2. Recommended Placement.....	2-2
Figure 2-3. Installation Using Tie Down Washers.....	2-3
Figure 2-4. Install Fuel Pump, Outlet Side Up.....	2-4
Figure 2-5. Fuel Pump Must Be in Vertical Position .....	2-4
Figure 4-1. Dash Assembly - View 1 of 2 .....	4-1
Figure 4-2. Dash Assembly - View 2 of 2 .....	4-2
Figure 4-3. Location of Chemical Metering Control and Chemical Pump Selector Valve .....	4-6
Figure 4-4. Location of Blower Lube Port.....	4-9
Figure 5-1. Service the Valves.....	5-6
Figure 5-2. Recirculation Fitting.....	5-11
Figure 6-1. Flow Diagram - View 1 of 3.....	6-6
Figure 6-2. Flow Diagram - View 2 of 3.....	6-7
Figure 6-3. Flow Diagram - View 3 of 3.....	6-8
Figure 7-1. Electrical Schematic.....	7-2
Figure 7-2. Wiring Diagram - View 1 of 3 .....	7-3
Figure 7-3. WiringDiagram - View 2 of 3 .....	7-4
Figure 7-4. Wiring Diagram - View 3 of 3 .....	7-5
Figure 9-1. Machine Assembly - View 1 of 5 .....	9-2
Figure 9-2. Machine Assembly - View 2 of 5 .....	9-3
Figure 9-3. Machine Assembly - View 3 of 5 .....	9-4
Figure 9-4. Machine Assembly - View 4 of 5 .....	9-5
Figure 9-5. Machine Assembly - View 5 of 5 .....	9-6
Figure 9-6. Frame Assembly - View 1 of 3 .....	9-8
Figure 9-7. Frame Assembly - View 2 of 3 .....	9-9
Figure 9-8. Frame Assembly - View 3 of 3 .....	9-10
Figure 9-9. Engine Assembly.....	9-12

Figure 9-10. Dash Assembly - View 1 of 2 .....	9-14
Figure 9-11. Dash Assembly View 2 of 2.....	9-15
Figure 9-12. Electrical Control Panel Assembly .....	9-17
Figure 9-13. Blower Heat Exchanger Assembly .....	9-19
Figure 9-14. Water Box Assembly .....	9-20
Figure 9-15. Pump Assembly .....	9-21
Figure 9-16. Chemical Pump Assembly .....	9-22
Figure 9-17. Fuel Pump Assembly .....	9-23
Figure 9-18. Blower Assembly.....	9-24
Figure 9-19. Vacuum Relief Valve (Collector Box) Assembly .....	9-26
Figure 9-20. Exhaust Assembly.....	9-27
Figure 9-21. Diverter Valve Actuator Assembly .....	9-29
Figure 9-22. Hi PSI Manifold Assembly .....	9-30
Figure 9-23. By-Pass Valve Assembly.....	9-32
Figure 9-24. Chemical Jug Tray Assembly .....	9-33
Figure 9-25. Briggs and Stratton Voltage Regulator Modification .....	9-34
Figure 9-26. 70 Gallon Universal Recovery Tank Assembly.....	9-35
Figure 9-27. 70 Gallon Universal Recovery Tank (URT) Cover Assembly .....	9-37
Figure 9-28. 100 Gallon Universal Recovery Tank (URT) Assembly.....	9-38
Figure 9-29. 100 Gallon Universal Recovery Tank (URT) Cover Assembly .....	9-40
Figure 9-30. 85 Gallon Rotomolded Tank Assembly - View 1 of 2 .....	9-41
Figure 9-31. 85 Gallon Rotomolded Tank Assembly - View 2 of 2 .....	9-42

*BOXXER*<sup>™</sup>  
421



# 1- General Information

The Boxxer 421 is a compact, yet powerful truckmount carpet cleaning system which can also be used for hard-floor cleaning and pressure washing. This high performance machine features a 21 Hp Briggs and Stratton engine and the dual oil bath Tuthill Dominator 4005 Tri-lobe Blower, which provides low noise, low vibration operation. The advanced heat exchanger system utilizes two separate exhaust heat exchangers for capturing “free heat”.

The Boxxer 421 comes standard with a 70 gallon recovery tank (shown in Figure 1-1), a 5 gallon chemical jug, 100 ft vacuum and solution hoses and a 10 ft whip hose.



**Figure 1-1. Boxxer 421 with Standard 70 Gallon Recovery Tank**

Options include:

- a 100 gallon recovery tank
- an Automatic Pump Out (APO) system
- a Thru Floor Exhaust Kit
- an 85 gallon fresh water tank



## SYSTEM CONCEPT

The Boxxer 421 truckmount carpet cleaning system has many functions to perform simultaneously.

- The engine has to run at a consistent rpm.
- The vacuum has to pull air and dirty water back from cleaning site.
- The water pump provides stable pressure at proper water flow for cleaning.
- The chemical has to be injected into the water stream at the right concentration.
- The heating system must maintain proper heat.
- The recovery tank must store dirty water until drained.

This is how the Boxxer 421 integrates all the functions:

Water is fed into the machine under tap pressure and it flows through the water conditioner to the water box. (The water conditioner is offered as an option.) The solution is then picked up by the high pressure pump and pressurized to the desired level. The water then splits flow, as demanded by the technician.

The majority of the water flows to the by-pass valve assembly, then back to the water box. The water flows from the water pump through the blower exhaust heat exchanger then through the engine exhaust heat exchanger and out to the cleaning tool.

When the cleaning solution reaches a preset high temperature, it is released from the system and directed to the recovery tank. Then cool water enters the system to regulate the temperature. The engine exhaust diverter bypasses the heat from the exhaust heat exchanger and simultaneously releases water from the system and directs it to the recovery tank.

As there is no guess work in the manufacture of these highly advanced cleaning machines, there must be none in preparing it to get the job done in the field. It is the purpose of this manual to help you properly understand, maintain and service your cleaning plant.

The manual contains installation and operation instructions as well as information required for proper maintenance, adjustment and repair of Boxxer 421. Component troubleshooting charts have also been included for your convenience. Follow the directions carefully and you will be rewarded with years of profitable, trouble-free operation.

It is imperative that no section be overlooked when preparing for operation of this equipment.

This section of the manual contains the following information:

- Contact Information
- Warnings, Cautions and Notices
- Responsibilities
- Machine Specifications
- High Altitude Operation
- Local Water Precautions

## CONTACT INFORMATION

If you have any questions regarding the operation, maintenance or repair of this machine, please contact your local distributor.

To find a local distributor, please visit our website at <http://hydramaster.com/HowToBuy/DealerLocator.aspx>

If your question cannot be resolved by your distributor or by the information within the Owner's Manual, you may contact HydraMaster direct using the following phone numbers.

HOURS	TELEPHONE NUMBERS	E-MAIL ADDRESSES
Monday-Friday 7:00 a.m. to 5:00 p.m. Pacific Standard Time	<b>Technical Support</b> (425) 775-7275 FAX : (800) 426-4225	<b>Technical Support</b> techsupport@hydramaster.com
	<b>Customer Service/Parts</b> (425) 775-7276 FAX: (425) 771-7156	<b>Customer Service/Parts</b> parts@hydramaster.com

When calling your distributor, be sure to reference the serial number and date of purchase.

### FOR YOUR REFERENCE:

**Serial No.** \_\_\_\_\_

**Date of Purchase:** \_\_\_\_\_

**Purchased From (Distributor):** \_\_\_\_\_

## WARNINGS, CAUTIONS AND NOTICES

### **⚠ WARNING**

HydraMaster uses this WARNING symbol throughout the manual to warn of possible injury or death.

### **CAUTION**

This CAUTION symbol is used to warn of possible equipment damage.

### **NOTICE**

This NOTICE symbol indicates that federal or state regulatory laws may apply, and also emphasizes supplemental information.

Warnings and Cautions specific to the Boxxer 421 include the following:

**⚠ WARNING**

**ENGINE COOLING:** Units employing internal combustion engines must not be enclosed within a van with doors and windows closed. Excessive temperatures within the engine will result in premature engine failure and a compromise of applicable warranty.

**⚠ WARNING**

**MOVING PARTS:** Never touch any part of the machine that is in motion. Severe bodily injury may result.

**⚠ WARNING**

**HOT SURFACES:** During the operation of this equipment, many surfaces on the machine will become very hot. When near the van for any reason care must be taken not to touch any hot surface, such as heater, engine, exhaust, etc.

**⚠ WARNING**

**HEARING PROTECTION:** The Occupational Safety and Health Administration (OSHA) recommends the use of hearing protection when a technician is exposed to an *average* of 85 decibels (this is an average of exposure over an 8 hour period). This equipment can produce 85 decibels to a distance of 10 feet. Please check with your local state agencies to see if OSHA standards apply to your application.

**⚠ WARNING**

**NO SMOKING:** It is unsafe to smoke in or around the vehicle.

**⚠ WARNING**

**CARBON MONOXIDE:** This unit generates toxic fumes. Position the vehicle so that the fumes will be directed *away* from the job site. *Do not park where exhaust fumes can enter a building through open doors, windows, air conditioning units or kitchen fans.*

**⚠ WARNING**

**TOXIC FUMES:** Do not occupy the vehicle when the cleaning equipment is operating. Toxic fumes may accumulate inside a stationary vehicle.

**⚠ WARNING**

**ENGINE EXHAUST:** The engine exhaust from this product contains chemicals known to the State of California to cause cancer, birth defects or other reproductive harm.

**⚠ WARNING**

**PORTABLE GAS TANK:** Never operate this machine with a portable gas can inside the truck. Doing so increases the risk of a fire or explosion.

**⚠ WARNING**

**TRANSPORTATION OF FUEL CONTAINERS:** Transportation in a vehicle of any vented fuel container that presently has or has ever contained a flammable liquid is strictly forbidden by HydraMaster and by federal and state regulation.

**CAUTION**

**THROUGH-FLOOR DRILLING:** Be cautious when drilling holes through the van floor. Many vans have critical components mounted directly below the van floor that could be damaged by a misplaced drill bit.

**CAUTION**

**LEVEL OPERATION:** During operation, van or trailer must be parked on level ground not to exceed + or - 10 degrees. Failure to insure proper leveling may prevent proper internal lubrication of engine, vacuum and/or high pressure components.

**CAUTION**

The machine cannot be run in the IDLE position for cleaning upholstery, carpet or flood extraction. This will void the warranty.

**CAUTION**

**ACID RINSE AGENTS:** The increased demand for “clear water” rinsing results in the need for special care when using these acid based chemicals in your equipment. The negative side of these products is the corrosive effects the acid can have on metals, including swivels, pumps, heat exchangers, etc.

**CAUTION**

HydraMaster's *ClearWater Rinse* has been formulated to protect vital components. HydraMaster will not warranty parts that have been damaged from using unprotected acid products that have obviously caused failures.

**CAUTION**

**HARD WATER PROTECTION:** Failure to take appropriate measures to prevent scale build up can result in **system failure** and **loss of warranty** on affected parts. Test the water in your immediate and surrounding areas with hard water test strips. Assume all water obtained from wells is hard. If you are operating in a "Hard Water Area" (3.0 grains or more per gallon), use a water softening system.

**CAUTION**

**FREEZE PROTECTION:** There is often little warning before a cold spell. Therefore, not protecting this equipment from freezing will result in costly downtime. Placing an electric heater in the truck or parking the truck indoors will help to insure against freezing, but should not be the primary method of freeze protection.

**CAUTION**

**EXHAUST SYSTEM:** Do not allow flammable material (i.e. oil, fuel, plastic or wood products) to come in contact with the exhaust system.

**CAUTION**

The use of some chemicals through your mobile carpet cleaning plant can seriously damage the internal plumbing, high-pressure pump, chemical pump and heat exchangers. These harmful chemicals include concentrated acid (see the pH chart at the end of this section), solvents (including d-Limonene), and some paint, oil and grease removers with a high concentration of solvents.

## RESPONSIBILITIES

### Purchaser's Responsibilities

- Prior to purchasing a van, ensure that the payload is suitable for all of the equipment that will be installed and transported. This includes and is not limited to: the truckmount, recovery tanks, fresh water tanks, on-board water, hose reels, hoses, cleaning tools, chemicals and drying equipment. Payload capacity information is available through the auto dealer, the manufacturer's web site, and is also located on the door pillar of the driver's side door.
- Purchase a 42 - 60 Amp hour battery and have the battery 'slow' charge if it is new. The battery is normally available from the installation dealer.

### CAUTION

If the battery is not fully charged, damage can occur to the engine charging regulator.

- Prior to dropping your van off at the distributor for the truckmount to be installed, have a spray-on bed liner applied to the floor such as Rhino Lining® or Line-X®.

### NOTICE

Plywood and carpet are not recommended.

- Prior to operating the truckmount, read this manual in its entirety and familiarize yourself with the information contained here. Special attention should be paid to all **Warnings and Cautions**.
- The distributor is responsible for the correct installation of the truckmount. The distributor is also responsible to train you in the correct and proper operation and maintenance of the truckmount.

### NOTICE

Any modification of the truckmount may void the warranty.



## **Distributor's Responsibility**

### **Acceptance of Shipment**

Before accepting the truckmount, check the following

1. The truckmount should be free from any damage during shipping. Do not sign the delivery receipt until you have closely inspected the truckmount and noted any damage on the delivery receipt. Hidden damage may be present even if the box looks okay. It is recommended that the box be opened before you sign for the shipment.
2. Check the packing list and verify that all items are accounted for.

### **Installation Responsibilities**

- Ensure proper payload capacity. It is the distributor's responsibility to verify that the equipment package does not exceed the vehicle capacity.
- Ensure installation of a safe fuel tap system and through-floor fittings as provided by HydraMaster.
- Ensure proper placement of the truckmount, recovery tank, fresh water tank, and accessories in the vehicle, and check that they are secured with bolts and back up plates. The distributor should verify that the owner is in agreement with the layout.
- Ensure proper connection of the fuel lines.
- Ensure proper connection and installation of the battery. Verify that the battery is in accordance with HydraMaster's recommendation.
- Check the pump, vacuum blower and engine oil levels prior to starting the truckmount.
- Start and run the truckmount and check that all systems function properly.
- Test all hoses, wands and other accessories for correct operation.
- Ensure timely return of the document package.



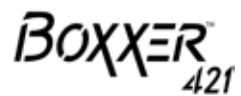
### Training

The distributor should provide a thorough review of the operation manual with the purchaser along with instruction and familiarization in

- How all the truckmount's systems function.
- All safety precautions and their importance.
- How to correctly start and shut down the truckmount.
- How to correctly clean with the truckmount.
- Where and how often to check and change component oil levels.
- Freezing damage and how to avoid it. This includes explaining proper freeze guarding procedures.
- How to do basic troubleshooting of the truckmount.
- Hard water damage and how to avoid it. This includes how to determine if hard water exists in your area and the installation and use of water softening systems.
- The truckmount's warranty and warranty procedures.

## MACHINE SPECIFICATIONS

Frame	24"W x 32"H x 36"D	
	Steel with Baked-on Powder Coated Finish	
Weight	709 lbs.	
Engine	Vanguard 21 HP Briggs and Stratton	
	Pressurized Oil System	Engine Oil: 5W-30 Synthetic
	Spin-on Filter, Oil Cooler	
Ignition	Electric Keystart	
Vacuum Blower	Dominator 4005, Tuthill/M-D Tri-Lobe,	Blower Oil: Pneulube
Pump	HydraPump II, 3.5 gpm Hot Seals, 2,500 psi	Pump Oil: 15W-50 Synthetic
Chemical System	Last-Step Chemical	
Operating Pressure	Up to 1,000 psi	
Heating System	1 Stainless Steel Engine Exhaust Exchanger	
	1 Coil and Fin Blower Exhaust Heat Exchanger	
Instruments	Water Pressure Gauge, Liquid Filled, 0 - 1,500 psi	
	Hour Meter,	Machine Runtime
	Keyed Ignition, Start/Stop	
	Chemical Flowmeter, Clear Acrylic, 0 - 10 gph	
	Vacuum Gauge	
	Temperature Gauge	
Recovery Tank	70 Gallon Aluminum, Powder Coated Finish	
Cleaning Wand	Stainless Steel 'S'-bend	
	Replaceable Grip	
	Rebuildable Solution Valve	



High Pressure Solution Hose	100 ft , 1/4" High Temperature Lined/ Vinyl Covered	
	Hose Rated to 2,250 psi	
Vacuum Hose	100 ft, 2" Reinforced Hose, 10 ft, 1 1-2" Reinforced Wand Whip Line	
Standard Equipment	Chemical Jug	
	Battery Box	
	Van Decal Package	
	Van Installation Kit	
	Owner's Manual (on CD)	
	Owner's Guide (paper)	
	HydraMaster Jacket	

## HIGH ALTITUDE OPERATION

Elevation plays a key role in how the truckmount will operate. Operation at high altitude (above 5,000 ft) may require a high-altitude carburetor jet. Use of this jet at high altitude will improve power, reduce fuel consumption and help reduce excessive carbon build-up in the exhaust and heat exchanger systems.

Contact the local Briggs and Stratton dealer or HydraMaster to obtain the proper jet size. Find your local Briggs and Stratton dealer at <http://vanguardengines.via.infonow.net/locator>.

## LOCAL WATER PRECAUTIONS

The quality of water varies greatly. Many areas have an excess of minerals in the water which results in what is commonly called “hard water.” These minerals tend to adhere to the insides of heater coils and other parts of the machines causing damage and a loss of cleaning effectiveness. This influences the reliability and efficiency of equipment in direct proportion to the level of hardness.

### Hard Water Advisory

HydraMaster recognizes that any hard water deposits which might occur within the water system of our truckmounts is a serious problem. The precision technology of truckmount heat exchanger systems is intolerant of any foreign material. Hard water deposits will ultimately decrease the performance of the system and are expected to seriously lower the reliability of the machine.

To validate a machine’s warranty, HydraMaster requires that all machines operating in designated “Hard Water Areas” (3.0 grains or more per gallon) be fitted with a water softening system, or a properly installed magnetic-type descaler must be used and maintained. Periodic descaling or acid-rinsing alone is not adequate in these areas. HydraMaster does not recommend any particular type or brand; however, the relative effectiveness of some types of magnetic descalers or softeners may require additional periodic use of descaling agents.

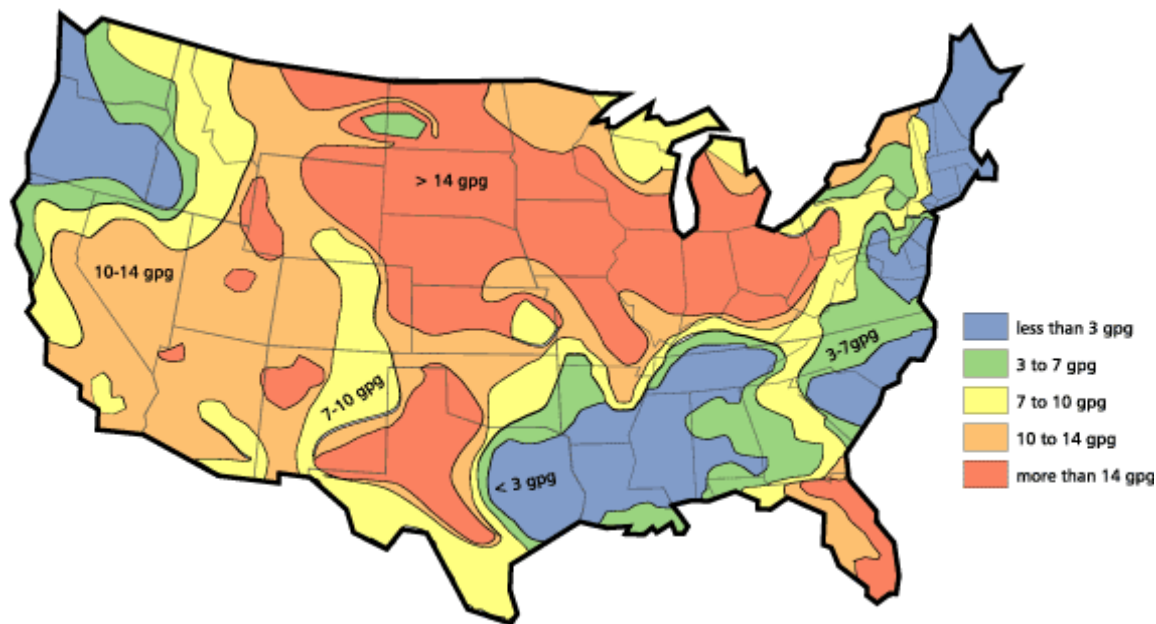
HydraMaster also recommends, in the strongest possible terms, that machines in all areas be fitted with a water softening system for improved operation and reliability.

## **CAUTION**

Failure to take appropriate measures to prevent scale build up can result in system failure and loss of warranty on affected parts.

### Hard Water Area Map

The hard water map, shown in Figure 1-2, defines hard water areas in the continental United States which compromise fluid related components such as hoses, fittings, heaters, pumps, valves and water-cooled engines. For other countries, hard water area maps can be obtained from geological societies.



**Figure 1-2. Hard Water Map of Mainland United States**

### **NOTICE**

The map shown in Figure 1-2 is provided for general reference only. Water hardness in your geographical location should be confirmed by testing.

**Water Softener**

Cleaning efficiency and equipment life is increased, chemical use decreased, and the appearance of cleaned carpets enhanced when water softeners are incorporated in hard water areas. HydraMaster strongly urges the use of water softener units with the Boxxer 421 in areas exceeding 3.0 grains per gallon.

Failure to use a water softener in these areas will invalidate the machine's warranty. Referring to the hard water area map shown Figure 1-2, determine the quality of water in your area and take immediate action if the water hardness exceeds 3.0 grains per gallon.

The relatively low cost of a water softener service is more than made up for by an increased life of machine parts, reduced chemical costs and continued cleaning efficiency. The water softener will also increase the effectiveness of the cleaning chemicals, therefore less chemical will be needed.

Contact a water softener distributor in your area for information on the rental of a simple water treatment unit to carry in your truck. Be sure to charge the water softener in accordance with the capability of the softener.

For example: If the softener will treat 900 gallons of water and the machine uses an average of 30 gallons/hour, for an average of 5 hours a day, this equals 150 gallons per day. In 6 days the machine would use 900 gallons of water. Therefore, the softener would need to be charged every 6 working days for maximum softening.



### **Waste Water Disposal Advisory**

There are laws in most communities prohibiting the dumping of recovered “gray” water from carpet cleaning in any place but a sanitary treatment system.

The cleaning rinse water, recovered into your unit’s vacuum recovery tank, contains materials such as detergents, and must be safely processed before entering streams, rivers and reservoirs.

In most cases, an acceptable method of waste water disposal is to discharge into a municipal sewage treatment system after first filtering out solid material such as carpet fiber. Access to the sanitary system can be obtained through a toilet, laundry drain, RV dump, etc. Permission should first be obtained from any concerned party or agency.

One disposal method which usually complies with the law is to accumulate the waste water and haul it to an appropriate dump site. Another solution to the disposal problem is to equip your Boxxer 421 with an Automatic Pump-Out System (APO). These systems are designed to remove waste water from the extractor’s recovery system and actively pump the water through hoses to a suitable disposal drain.

HydraMaster makes an APO System which can be ordered with new equipment or installed later.

When properly configured, the systems will continuously monitor the level of waste water and pump it out simultaneously with the cleaning operation. The hidden benefit of this process is that the technician does not have to stop his/her cleaning to empty the recovery tank.

## **NOTICE**

**IN ACCORDANCE WITH EPA, STATE AND LOCAL LAWS, DO NOT DISPOSE OF WASTE WATER INTO GUTTERS, STORM DRAINS, STREAMS, RESERVOIRS, ETC.**

The penalties for non-compliance can be serious. Always check local laws and regulations to be sure you are in compliance.



## 2- Installation Information

When selecting a truck, remember the preferable vehicle for a Boxxer 421 installation is a cargo van with a heavy-duty suspension package and a half ton capacity. If a fresh water tank is added, a three quarter ton or larger capacity van, with a 2,400 lb. payload capacity, is required.

### **CAUTION**

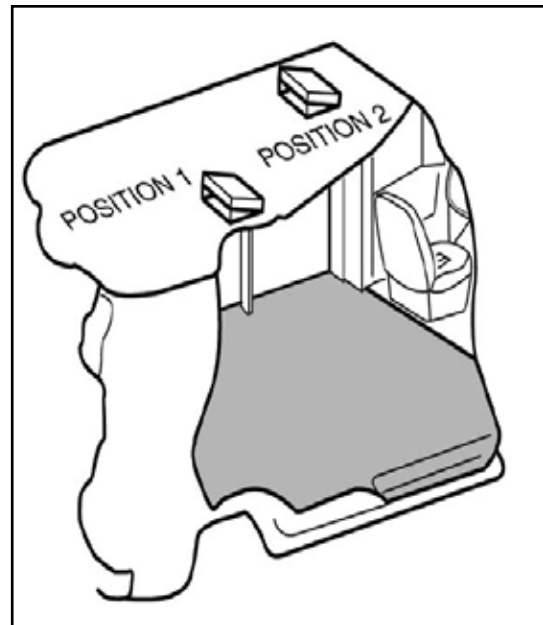
Be cautious when drilling any holes through the van floor. Many vans have critical components mounted directly below the van floor that could be damaged by a misplaced drill bit.

### **Truck Preparation**

The manufacturer recommends the installation of a spray-on bed liner in the vehicle prior to installation of machine.

This provides 'metal to cushion' mounting rather than 'metal to metal' and makes for an attractive van interior.

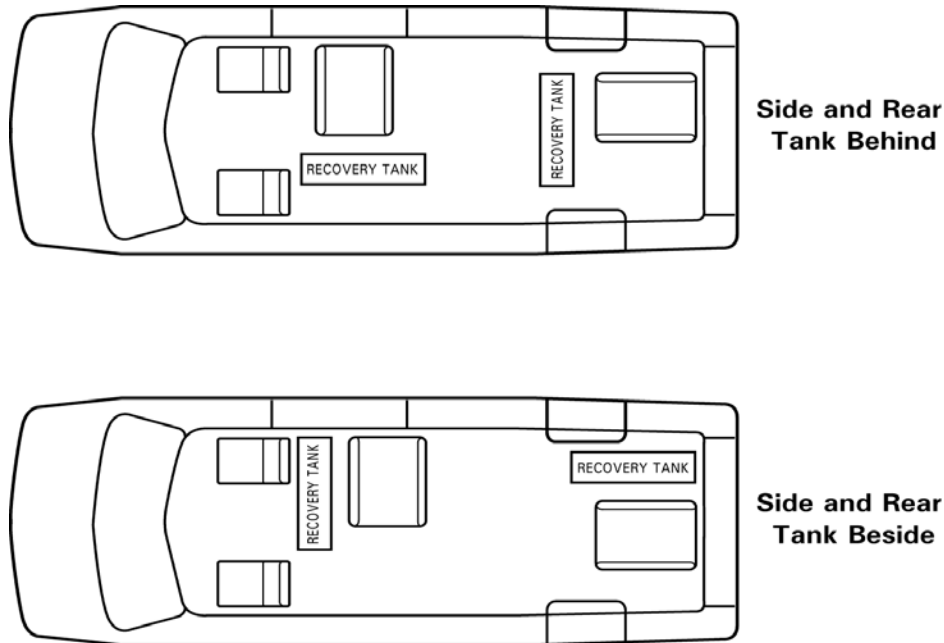
It is highly recommended that you have roof vents installed in vehicles operated in hot weather locations. Roof vent positions are shown in Figure 2-1.



**Figure 2-1. Roof Vent Positions**

## Placement Of Unit In Vehicle

There are two recommended unit placements (see Figure 2-2).



**Figure 2-2. Recommended Placement**

### Side Door

Most installations are side door. This provides rear access for accessories and hoses as well as unobstructed access to the component/working side of the machine, thus making it a bit easier to perform maintenance and/or repair without removing the unit from the truck.

### Rear Door

Although this location partly limits working access, it does direct the noise away from the cleaning site. Some cleaners in the colder areas prefer this location because it puts the weight over the rear wheels for better traction in ice and snow. Rear mounting requires the unit to be slid to the right side as far as possible.

This not only provides adequate working space on the component side of the unit but also improves weight distribution inside the van (engine and component weight line up over drive shaft). Also, it is physically easier to load the unit into the rear door due to the height of the van bed.

**Machine Tie Down Washers**

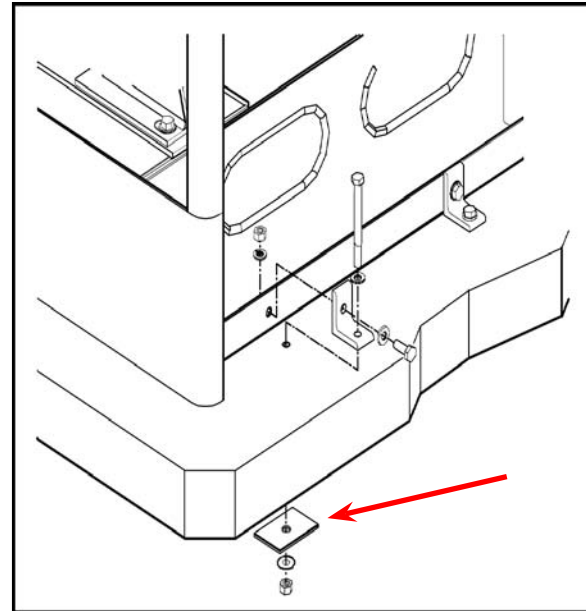
Secure the machine to the floor of the van with the four tie down washers provided. This safety measure will ensure that the machine will not slide inside the van. See Figure 2-3 for the correct installation.

**⚠ WARNING**

Ensure that the machine is well secured to the floor of the van with the hardware supplied. A sudden or crash stop will cause the machine to rocket forward. Protect yourself and the machine. **SECURE IT!**

**⚠ WARNING**

It is recommended by the manufacturer that the exhaust from the front of the machine be vented down under the truck to prevent carbon monoxide from entering the job site. **Always park the truck so the exhaust is blowing away from the job site.**



**Figure 2-3. Installation Using Tie Down Washers**

**⚠ WARNING**

Never operate this machine with a portable gas can inside the truck. Doing so increases the risk of a fire or explosion.

Mount a fire extinguisher just inside the rear or side door for emergencies.

**⚠ WARNING**

Transportation in a vehicle of any vented fuel container that presently holds or has ever held a flammable liquid is strictly forbidden by HydraMaster and by federal and state regulation.

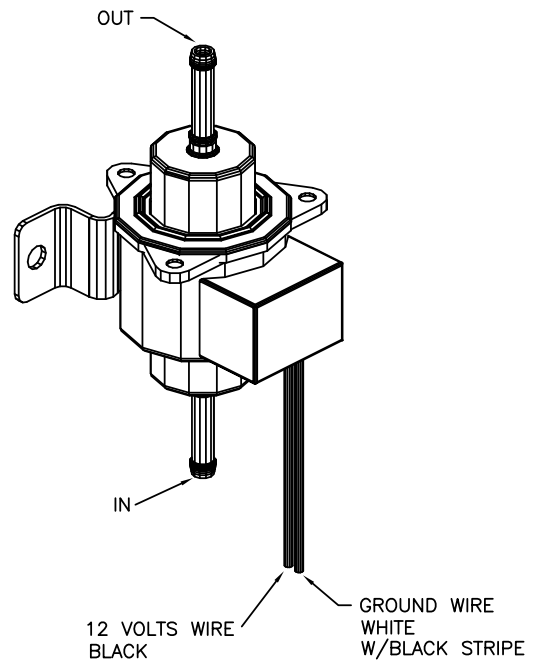
**⚠ WARNING**

The engine exhaust from this product contains chemicals known to the State of California to cause cancer, birth defects or other reproductive harm.

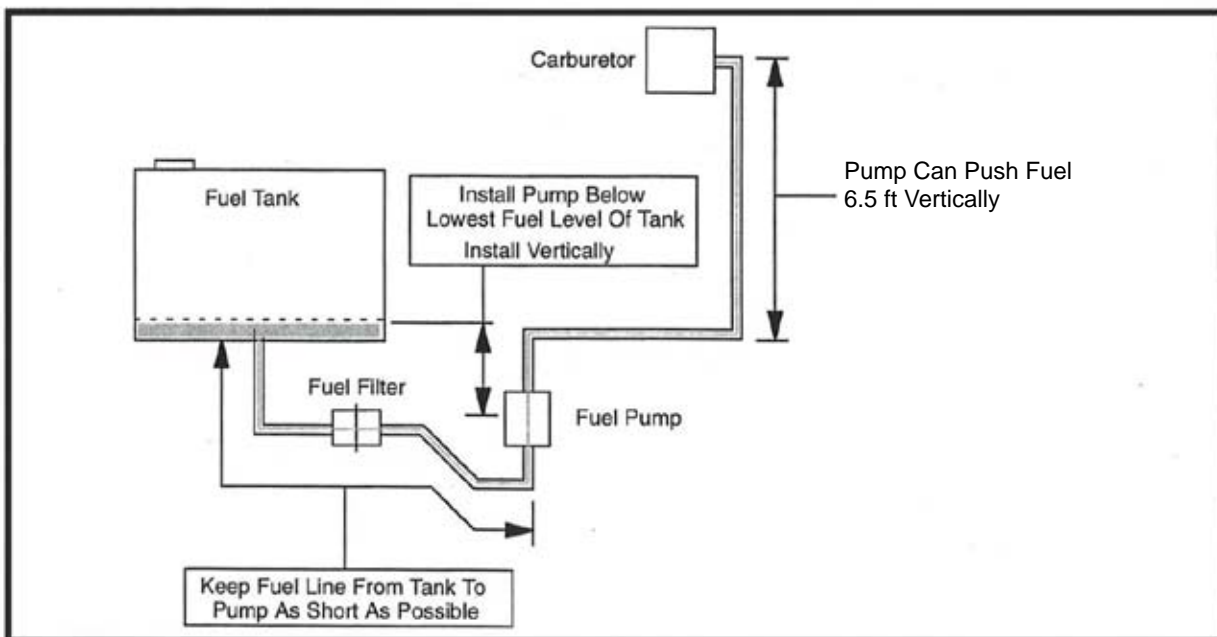
## ORIENTATION OF FUEL PUMP

For proper fuel pump operation and fuel flow, the vehicle's fuel pump must be installed in a lower position with respect to the fuel tank and in as vertical a position as possible (outlet side up - see Figure 2-4 and Figure 2-5).

Mount the fuel pump away from sources of heat.



**Figure 2-4. Install Fuel Pump, Outlet Side Up**



**Figure 2-5. Fuel Pump Must Be in Vertical Position**

# 3 - Cleaning Information

The Boxxer 421 has been engineered using the latest and most sophisticated technology available to produce the finest carpet cleaning results possible. Despite this, it remains only a tool of the carpet cleaning trade and can produce only as good a job as the person operating it.

HydraMaster strongly recommends attending an Institute of Inspection, Cleaning and Restoration Certification (IICRC) approved school as soon as possible and to always follow the IICRC guidelines when cleaning carpets or hard surfaces.

This section describes the carpet cleaning procedure in the following areas:

- Precautions
- Preparing the Carpet for Extraction
- Rinse and Recover
- Overwetting
- Streaking
- Cleaning Tool Tips



## PRECAUTIONS

The use of some chemicals (such as concentrated acids and/or solvents) in your truckmount can seriously damage the internal plumbing and high pressure pump.

HydraMaster strongly recommends purchasing a water softener system to prevent the buildup of scale and hard water deposits in your truckmount.

HydraMaster recommends only the use of chemicals containing rust and corrosion inhibitors and water softening agents to prevent chemical buildup which may lead to component failure and warranty invalidation.

Increased demand for a neutralizing rinse results in the need for special care when using these acid based chemicals in your truckmount. The negative side of these products is the corrosive effects the acid can have on metals, including fittings, pumps, heat exchangers, etc.

HydraMaster's **ClearWater Rinse™** has been formulated to protect vital components. HydraMaster will not warranty parts that have been damaged from using acid products that have obviously caused failures.

## PREPARING THE CARPET FOR EXTRACTION

### Pre-vacuum the carpet

Whether you instruct the customer to pre-vacuum or you offer it as part of your service, proper vacuuming will make your job easier with superior end results. The more time spent removing loose particulate soil, the easier it will be to remove the oily soil stuck to the fibers.

### Pretreat the carpet

This process of applying traffic lane type chemicals to the carpet (whether by sprayer or rotary scrubber) is essential prior to extraction with your truckmount.

By applying cleaning agents to the carpet and letting them dwell 10-20 minutes prior to rinsing, you allow the product to dissolve and emulsify the oily, sticky binders holding the soil to the fiber. This will allow more soil to be removed in one or two cleaning passes and help prevent over-wetting.

Remember the solution coming out of your cleaning tool is only in contact with the carpet fiber for a few seconds. Relying on the rinse detergent to do the majority of the cleaning will result in overly long dry times and excess detergent residue left in the carpet.

HydraMaster recommends the use of our pre-sprays: **Fastbreak™** for residential carpet and **Blitz™** for commercial carpet needs.

## **RINSE AND RECOVER**

Whether you are using a wand or an RX-20™, you should clean an area approximately 3 ft. x 3 ft. with the solution valve open then immediately go over that area with vacuum only to remove any excess moisture.

Olefin fiber is becoming more popular, particularly in commercial installations. The process mentioned above can leave excessive residual moisture because olefin fibers will not absorb any of the cleaning solution. You must only apply solution during the backward stroke of the wand so it can be immediately captured by the vacuum head. RX-20™ users should follow each pass with a dry pass. Failure to follow this procedure will cause solution to flow to the back of the carpet along with some of the soil. This, along with any soil imbedded in the backing, will be wicked to the surface of the fibers as the carpet dries.

HydraMaster recommends the following rinse aids: Alkaline - **Hydra-Dri Powder™** or **Hydra-Clean™**. Acid - **ClearWater Rinse™**.

## **OVERWETTING**

Overwetting is an annoyance to all concerned. Extended drying times will leave the customer with a negative impression of both the cleaning company and the process used.

Several factors that will cause over-wetting include:

1. Too few vacuum strokes.
2. Clogged vacuum blower filter or vacuum recovery tank lid not sealing properly.
3. Vacuum recovery tank drain valve left partially open.
4. Obstructed, cut or kinked vacuum hoses.
5. Obstructed vacuum hoses while cleaning a heavily foam-saturated carpet (it is recommended to use a crystal type defoamer distributed evenly over the carpet).

## **STREAKING**

Streaks in the carpet can appear in both clean or dirty areas and normally appear in heavily soiled, light colored carpets.

Possible reasons of streaking may include:

1. Clogged or improperly angled spray nozzles.
2. Spray nozzles that overlap, concentrating the solution.
3. A partially clogged vacuum head.
4. Inconsistent solution temperature.



## CLEANING TOOL TIPS

### Wands

With a wand, keep cleaning strokes short, front to back, and run a “dry pass”.

After pulling the wand for a strip of 3 or 4 ft long with the solution trigger activated, go back up to the top of the stroke, and make a “dry “ pass [i.e. no solution flowing]. This gives the wand a second chance to pick up the solution on the carpet.

If you do not run a dry pass, the carpet can take longer to dry, and, possibly, the pad under the carpet can become saturated.

Be aware of the carpet seams; try to use strokes that are parallel with the seam. Avoid pulling the wand across the seam. Every stroke can peel the seam connection and pull the carpet off the floor.

Also, tilt the wand handle down [head up] to move the tool forward, and away from you, on the carpet. This means less pull on the carpet and less work for you.





**1½" HydraHoe  
Carpet Cleaning Wand**

Glides over carpet without chattering! 12" wide head increases production. High temperature, high pressure, stainless steel fabrication, stainless valve, quick coupler and assist handle.

**Item #163-020**

**2" S-Bend Wand**

This 12" wide wand has two jets. It uses a 1¾" tube for improved airflow and comes with an expanded 2" vacuum hose connection.

**Item #163-104**

**1½" S-Bend  
Two Jet Wand**

This 12" wide S-Bend wand has two jets. It uses a 1½" tube and glides over the carpet for easy operation.

**Item #100-011-106**

**UT-14 Truckmount  
Stair Tool**

The best stair tool on the market today. This tough stainless steel hand tool is 14" long with 6" wide cleaning head and stainless steel valve with quick coupler, assist handle.

**Item #163-009**

**UT-40 Utility  
Cleaning Tool**

An all purpose tool for cleaning carpeted divider panels, under restaurant booths, landings, stairs and hard to reach carpeted areas. All stainless construction, 9" wide head and 40" long shaft allows operator to "stand-up" when cleaning stairs.

**Item #163-008**

## **Rotary Tool: RX-20**

Rotary tools are easier to move on the carpet, but harder to control at first. With a rotary tool, remember to keep strokes short and side-to-side.

Before turning on the RX-20, adjust the handle; it should rest right below or even with the bottom of your pants' front pockets, with the tool resting flat on the floor. Take your time in adjusting the tool's height; make sure the head of the tool is flat with the floor while you are holding the handle. Relax your posture; the more difficult it is to hold the tool's head flat on the floor surface, the more quickly you will tire.

While the tool is running, control the left and right movements of the tool by tilting the head to the front and back, and lifting the handles up and pushing the handles down. The tool can be driven to the forward and backward by tilting the head of the unit to the left and right. The head must be turning to use the self driving feature of the tool, and only requires a slight bit of pressure to handles to get the head to move the tool across the floor.

As with the wand, drying times will be improved if you run a dry pass between wet passes. Hold down the solution trigger and move the unit left or right across the floor 3 or 4 ft, then immediately back across the same pass, without the solution flowing, to make the dry pass. Make the next pass half-overlapping the previous pass.

Use the RX-20 in very heavily trafficked areas or if it has been a long time since the carpet has been cleaned. Beware of the seam edges of carpets and transition edges between floor surfaces. Use extreme caution when cleaning these areas.

Sometimes it is necessary to use an edge tool or wand to run the perimeter of the room on in difficult-to-reach areas where the circular head of the rotary units will not reach.

### ***For Truckmount & Portable Carpet Cleaning Systems***

- Aggressive Restorative Extraction Tool for Residential and Commercial Jobs
- Clean Carpet, Tile, and Grout with the RX-20 HE Total Floor Care System
- Works great on stains and heavily soiled, matted carpet.
- For truckmounts or portable carpet cleaning systems



The five vacuum heads and three spray jets rotate at 130 RPM creating 650 complete cleaning passes per minute.



### **Upholstery Tool: DriMaster**

Use the upholstery tool on small rugs and furniture. When you clean rugs, be sure that the temperature and chemicals are safe for that particular type of rug.

As with the larger tools, do not leave the surface of the upholstery too wet. Adjust the volume of water on the tool without it touching any surface: the water should just barely come out of the tool before the vacuum pulls it back in. The water will only just spray the top layer of the furniture and the vacuum will pull the dirty water back into the tool.

If you find it necessary to do a dry pass, keep strokes short to limit the amount of water that comes into contact with the fabric surface.

***DriMaster Upholstery Tool cleans faster, drier and better...all with less operator fatigue.***

- Ergonomically designed
- High flow/low residual moisture - super cleaning shears away soil
- No heat loss from atomizing solution
- Never needs a dry pass
- No overwetting or overspray to clean up - solution does not reach foam backing
- Fabrics are left 50% drier than conventional upholstery tools
- Durable - virtually unbreakable
- Lightweight with comfortable handgrip
- No trigger valve for less hand strain
- Cool to the touch
- Low profile design fits in tight spots

Combine the high performance cleaning of the DriMaster Tool with optional Comfort Grip and HydraMaster's state-of-the-art cleaning chemistry, and you're ready to treat most cleanable fabrics with fantastic results!



**Grip**  
**Part #000-061-144**

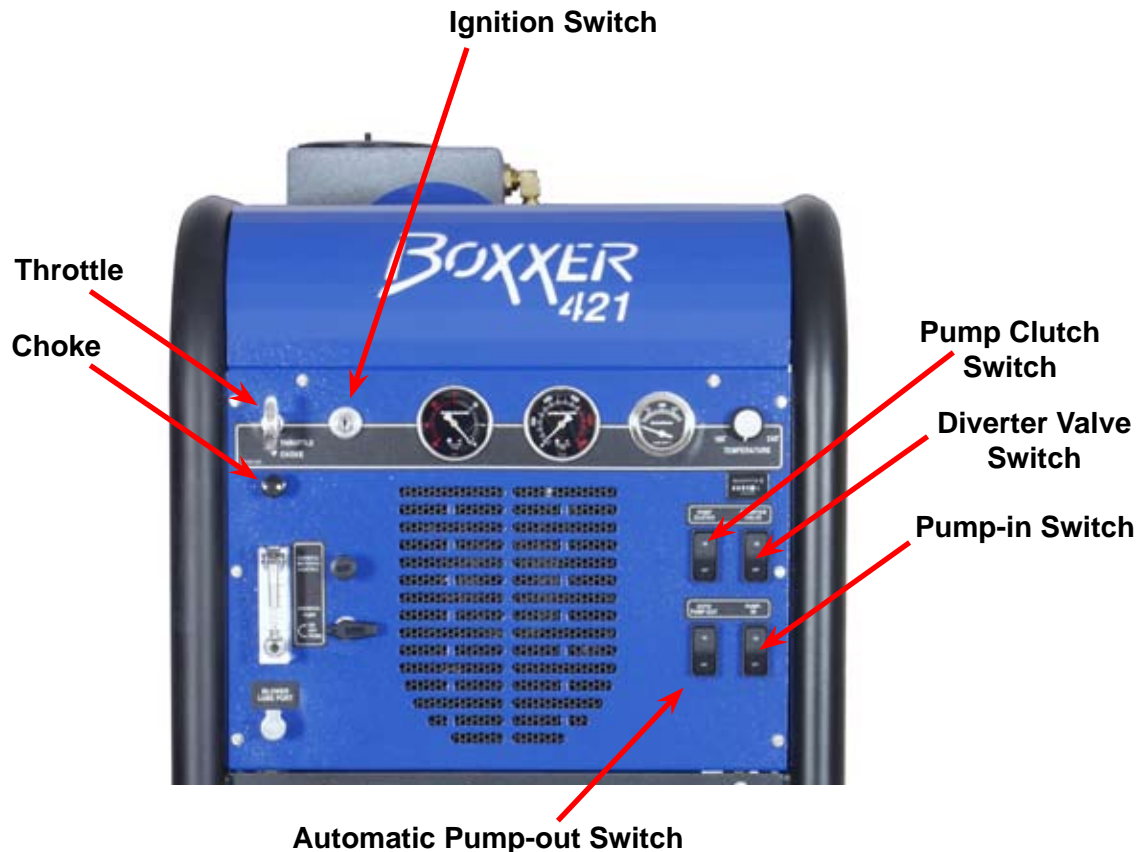


**Upholstery Tool**  
**Part #000-163-012**

*BOXXER*<sup>™</sup>  
421

# 4 - Operating Instructions

This section describes how to operate the Boxxer 421, starting with a description of the dash assembly (see Figure 4-1).

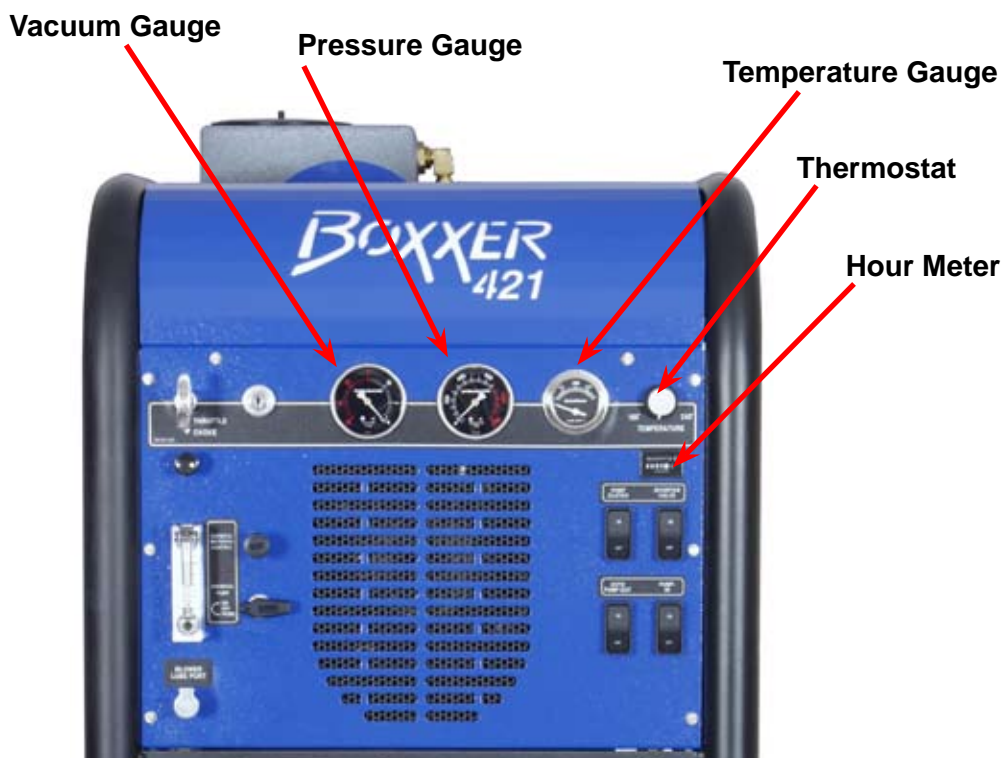


**Figure 4-1. Dash Assembly - View 1 of 2**

The dash assembly controls the:

- System's power on/off and speed
- Pump clutch
- Diverter valve
- Automatic Pump-Out (APO) if included in the configuration
- Pump-In system if included in the configuration

The dash assembly also includes the solution thermostat; the temperature, vacuum and pressure gauges; and the hour meter (see Figure 4-2).



**Figure 4-2. Dash Assembly - View 2 of 2**

## **EXHAUST DIVERTER SYSTEM**

The exhaust diverter system consists of two components:

1. Diverter valve
2. Pump clutch.

The diverter valve directs the flow of the exhaust through the coil heat exchanger or directly out of the machine via the diverter exhaust muffler.

The pump clutch allows the pump to be turned on and off through a switch. This will enable the machine to be used for flood extraction without the need for an inlet garden hose connected to the machine, thus preventing excessive filling of the recovery tank through the temperature control system.

The Boxxer 421 can run in two different modes: cleaning or flood extraction mode.



**Cleaning Mode**

To run the machine in cleaning mode:

1. Turn the PUMP CLUTCH switch and DIVERTER VALVE switch to the “ON” position.
2. Adjust TEMPERATURE SELECTOR knob to the desired temperature.

**Flood Extraction Mode**

To run the machine in flood extraction mode:

1. Turn the PUMP CLUTCH switch and DIVERTER VALVE switch to the “OFF” position.
2. Drain the water box completely.

**▲ WARNING**

When the machine is being run or after it has just been shut down, caution should be used around the muffler and the exhaust diverter surfaces as they become hot during operation. Failure to heed this warning may result in severe bodily injury.

**CAUTION**

Do not use excessive force when engaging and disengaging the heat exchanger bypass lever. This may cause damage to the exhaust diverter.

In order for the diverter valve to operate properly, it should periodically be engaged and disengaged.

## CAUTION

The diverter valve adjustment, explained in the following subsection, is to be performed only by the distributor, not by the owner. Warranty may be voided if the adjustment is made by anyone other than a certified distributor.

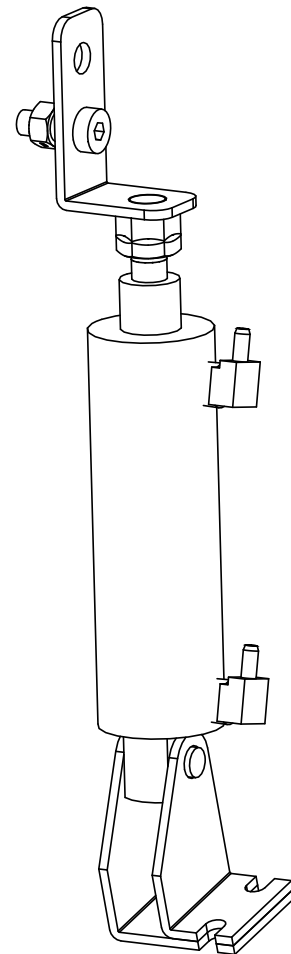
To find a local distributor, please visit our website at <http://www.hydramaster.com/HowToBuy/DealerLocator.aspx>.

### **Adjustment After Installation:**

Machines that are equipped with a diverter valve may need adjustment after the machine has been installed.

Prior to running the machine, perform the following steps:

1. Locate the actuator connected to the diverter valve arm which is located between the blower and engine exhaust heat exchanger.
2. The actuator shaft is connected to the diverter valve arm.
3. Pull the actuator shaft forward and listen if the poppet seals against the seat in the diverter valve.
4. Push the actuator shaft back and listen if the poppet seals against the seat in the diverter valve.
  - a. If the poppet seats in both directions, the diverter actuator is in proper adjustment.
  - b. If the poppet does not seat in one or both directions, the valve is out of adjustment. Perform the following steps to adjust the diverter actuator shaft.
5. The end of the actuator shaft is threaded into the diverter arm and is secured into position with a backup nut. This nut must be loosened to allow adjustment.
6. Loosen the actuator backup nut. This will allow you to rotate the actuator shaft clockwise or counterclockwise. Rotate the actuator shaft one half turn at a time. Then pull the actuator shaft forward and back. Listen to hear if the poppet seals in the seat of the diverter valve. Repeat this step until the diverter poppet seals in both directions.
7. Apply red Loctite on the thread of the actuator shaft. Retighten the backup nut.
8. Recheck the adjustment. Move the actuator shaft forward and back. If the diverter poppet seals in both directions, the diverter is now properly adjusted.





**START UP**

1. Perform daily and periodic maintenance as specified in this Owner's Manual.
2. Connect all required hoses, including a garden hose for water supply.
3. Connect the cleaning tool to the length of hose required to perform the cleaning.

**CAUTION**

The machine cannot be *run* in the "IDLE" position for cleaning upholstery, carpet or flood extraction. This will void the warranty.

**NOTICE**

In order to achieve consistent adjustable temperatures, an operating pressure of 200 psi must be maintained.

## CARPET OR HARD SURFACE CLEANING

1. Start the engine with throttle switch in "IDLE" position.
2. Allow machine to run in idle for 2 - 3 minutes to warm up.
3. Connect hoses.
4. Connect wand or tool.
5. Set THROTTLE to "HIGH".
6. If used, turn PUMP IN switch to "ON".
7. Turn PUMP CLUTCH switch to "ON".
8. Turn DIVERTER switch to "ON".
9. Set temperature to desired level.
10. If used, turn the AUTOMATIC PUMP-OUT switch to "ON".
11. Set cleaning pressure at desired level.

### Suggested settings

- a. Carpet Cleaning: 300 – 400 psi;
  - b. Hard Surface: 1,000 psi or as indicated on the tool.
12. Turn the CHEMICAL PUMP SELECTOR VALVE to the "PRIME" position to purge any air from the system (see Figure 4-3).
    - a. With the machine running at operating speed, block off the vacuum intake to the recovery tank. The vacuum gauge should read between 12" Hg and 14" Hg. This will assist in priming the chemical system.
    - b. When the chemical begins to flow through the flow meter, with the flow indicator reading maximum flow for at least 30 seconds, turn the CHEMICAL PUMP SELECTOR valve to "ON". The restriction can now be removed from the vacuum inlet.
    - c. Then, while spraying solution from the cleaning tool, adjust the chemical flow by turning the CHEMICAL METERING CONTROL knob as necessary.
  13. Commence cleaning.

Chemical  
Metering  
Control

Chemical Pump  
Selector Valve



**Figure 4-3. Location of Chemical Metering Control and Chemical Pump Selector Valve**

**UPHOLSTERY CLEANING**

1. Start engine with the THROTTLE switch in "IDLE" position.
2. Allow the machine to run in idle for 2 - 3 minutes to warm up.
3. Connect the hoses.
4. Connect the upholstery tool.
5. Set the THROTTLE to "HIGH".
6. If used, turn the PUMP-IN switch to "ON".
7. Turn the PUMP CLUTCH switch to "ON".
8. Turn the DIVERTER VALVE switch to "ON".
9. During upholstery cleaning if you desire a lower temperature you may want to leave the DIVERTER VALVE switch in the "OFF" position. The engine exhaust heat exchanger is bypassed; the heat will be obtained from the engine coolant and blower exhaust heat exchangers.
  - a. Set the temperature to the desired level.
  - b. If used, turn the AUTOMATIC PUMP-OUT switch to "ON".
10. Set the cleaning pressure at the desired level (300 – 400 psi).
11. Turn the CHEMICAL SELECTOR PUMP VALVE to the "PRIME" position to purge any air from the system.
  - a. When the chemical begins to flow through the flow meter, with the flow indicator reading maximum flow and the PRIME line pulsing, turn the CHEMICAL SELECTOR PUMP VALVE to "ON".
  - b. Then, while spraying solution from the cleaning tool, adjust the chemical flow by turning the CHEMICAL METERING CONTROL knob as necessary.
12. Commence cleaning.



## FLOOD EXTRACTION

1. Start the engine with the THROTTLE cable in “IDLE” position. Allow the machine to run in idle for 2 - 3 minutes to warm up.
2. Connect hoses.
3. Connect wand or tool.
4. Set the THROTTLE to “HIGH”.
5. If used, turn the AUTOMATIC PUMP-OUT switch to “ON”.
6. Commence water extraction.

### NOTICE

Make sure the PUMP CLUTCH and DIVERTER VALVE switches are in the “OFF” position.

## SHUT DOWN

1. Flush clear water through the chemical system for 10 seconds. Turn off the chemical flow meter.
2. Cool the machine by lowering the adjustable thermostat to the “LOW” position and the DIVERTER CONTROL switch to the “OFF” position. Spray the cleaning wand into the vacuum hose for 3 - 5 minutes. The chemical should now be flushed from the truckmount, hoses and cleaning tool.

## NOTICE

If the machine is not properly cooled, the water box can overflow.

3. Remove the vacuum hose.
4. Lubricate the blower to prevent it from rusting internally.
  - a. Allow the unit to run for a few minutes with the vacuum hose disconnected in order to remove moisture from the blower.
  - b. Cap off the inlet(s) to the vacuum tank.
  - c. Spray a HydraMaster-recommended spray lubricant into the “BLOWER LUBE PORT” for about 5 to 10 seconds while the unit is running (see Figure 4-4).
  - d. Uncap the inlet(s) and run the unit for another minute to allow the blower to cool down.
5. If freeze guarding is necessary, perform the freeze guard procedure at this time (see Section TBD for Freeze Guarding).
6. Lower the engine rpm to idle.
7. Turn the ignition switch to “OFF.”
8. Drain the water box.
9. Drain the vacuum tank. The vacuum filter should be cleaned prior to mobilization of the van.

Blower Lube Port



**Figure 4-4. Location of Blower Lube Port**

## NOTICE

In accordance with the EPA, state and local laws, **do not dispose of** waste water into gutters, storm drains, streams, reservoirs, etc.

10. Perform daily maintenance as specified in Section 5 of this Owner’s Manual.

*BOXXER*<sup>™</sup>  
421

# 5 - Machine Maintenance

To avoid costly repairs and downtime, it is imperative to develop and practice good maintenance procedures. These procedures fall into daily, weekly, monthly and quarterly increments and are outlined below. All maintenance must be performed by qualified service personnel.

A maintenance log, provided in the Owner's Guide, must be correctly and completely filled out. HydraMaster may request to inspect the logs before a warranty claim is honored. It is recommended that the log be affixed to the vehicle door near the truckmount for convenience and to serve as a maintenance reminder.

This section describes how to properly maintain the truckmount in the following areas:

- Operational Maintenance
- Overall Machine Maintenance
- High Pressure Pump Maintenance
- Vacuum System Maintenance
- Descaling Procedure (Required)
- Freeze Guarding



## **OPERATIONAL MAINTENANCE**

### **Daily:**

- Check engine oil level.
- Check high pressure pump oil. Add as necessary.
- Inspect garden hose screen. Clean as needed.
- Visually inspect machine for loose wires, oil leaks, water leaks, etc.
- Lubricate the blower with a HydraMaster-recommended lubricant.

### **Weekly:**

- Inspect vacuum recovery tank S/S filter.
- One time change of oil and oil filter after first 5-8 hours of use.
- Check oil level in blower.
- Check drive system screws. Tighten as needed.
- Check pump drive belt for wear.
- Check pump pulleys.
- Check high pressure water lines for wear or chafing.
- Check all nuts and bolts. Tighten as needed.
- Inspect vacuum relief valve. Clean and lubricate as necessary.
- Clean vacuum recovery tank thoroughly with high pressure washer.
- Check wiring for chafing.
- Flush water and chemical system with 50/50 white vinegar solution. .

### **Monthly**

- Change engine oil and oil filter (every 50 hrs).
- Change blower oil (every 50 hrs).
- Check engine air cleaner filter. Clean as necessary.
- Check water level in battery. Clean connections as needed.

### **Quarterly**

- Check fuel lines.
- Clean and gap spark plugs.
- Check drive coupler for cracks or wear. Replace as necessary.
- Change pump oil.

### **500 Hours**

- Replace plugs in the drive coupling, between the engine and the blower.



## **OVERALL MACHINE MAINTENANCE**

Maintaining the original appearance of your unit is important for two reasons:

1. It represents a big dollar investment for your cleaning business and its appearance should reflect that fact. A dirty machine is not professional.
2. Maintenance, troubleshooting, and repair is much easier to accomplish on a clean, well maintained unit. Regular cleaning of the machine offers you an opportunity to visually inspect all facets of the machine and spot potential problems before they occur.

The following maintenance is recommended by the manufacturer at the frequency indicated.

### **After Each Job**

- Check recovery tank and the filter basket.

### **Daily**

- Wipe machine down thoroughly with a damp cloth.
- Flush recovery tank out thoroughly.
- Remove, thoroughly clean and re-install S/S filter and blower filter screen in recovery tank. Grease threads.
- Inspect and clean vacuum slot on cleaning wand.
- Check wand head for sharp edges that could tear carpet. File down as needed.
- Clean wand to maintain original appearance.
- Wipe down vacuum and high pressure hoses as needed.
- Visually inspect hoses for cuts, etc.



### Weekly

- Wipe down entire unit as needed.
- Apply good coat of auto wax to all painted surfaces inside and out, and to control panel.
- Thoroughly clean recovery tank using high pressure hot water (unit with optional high pressure cleaning gun may be used for this).
- Remove flat filter in recovery tank and thoroughly clean, removing all lint build-up. Inspect for damage and re-install.
- Empty chemical from chemical container. Wash out thoroughly to remove any chemical build-up.
- Inspect chemical feed line strainer and use 50% white vinegar/water solution to remove any chemical build-up.
- Thoroughly clean wand and inspect for clogged jet, debris in vacuum slot and leaking fittings at valve.
- Apply light coat of auto wax to wand.
- Thoroughly clean vacuum and high pressure hoses including hose cuffs.
- Inspect for wear or damage to hoses and quick connect fittings.
- Inspect garden hose connect/adapter screen for debris. Remove and clean thoroughly.
- Inspect all lines for wear or abrasions that may cause possible leaks.

## HIGH PRESSURE PUMP

### Daily

Check the oil level and the condition of the oil. The oil level should be up to the center of the sight glass on the back of the pump.

### **CAUTION**

If the oil becomes discolored and contaminated, one of the oil seals may be damaged. Refer to the Service Section.

Do not operate the pump if the crankcase has been contaminated with water.

### **CAUTION**

Do not leave contaminated oil in the pump housing or leave the housing empty. Remove contaminated oil as soon as it is discovered and replace it with clean oil.

### Periodically

Change the oil after the first 50 hours of operation, and every 500 operating hours thereafter. When changing, remove the drain plug on the oil drain center located on the frame so all oil and accumulated sediment will drain out.

### **CAUTION**

Do not turn the drive shaft while the oil reservoir is empty.

### **CAUTION**

Protect the pump from freezing.

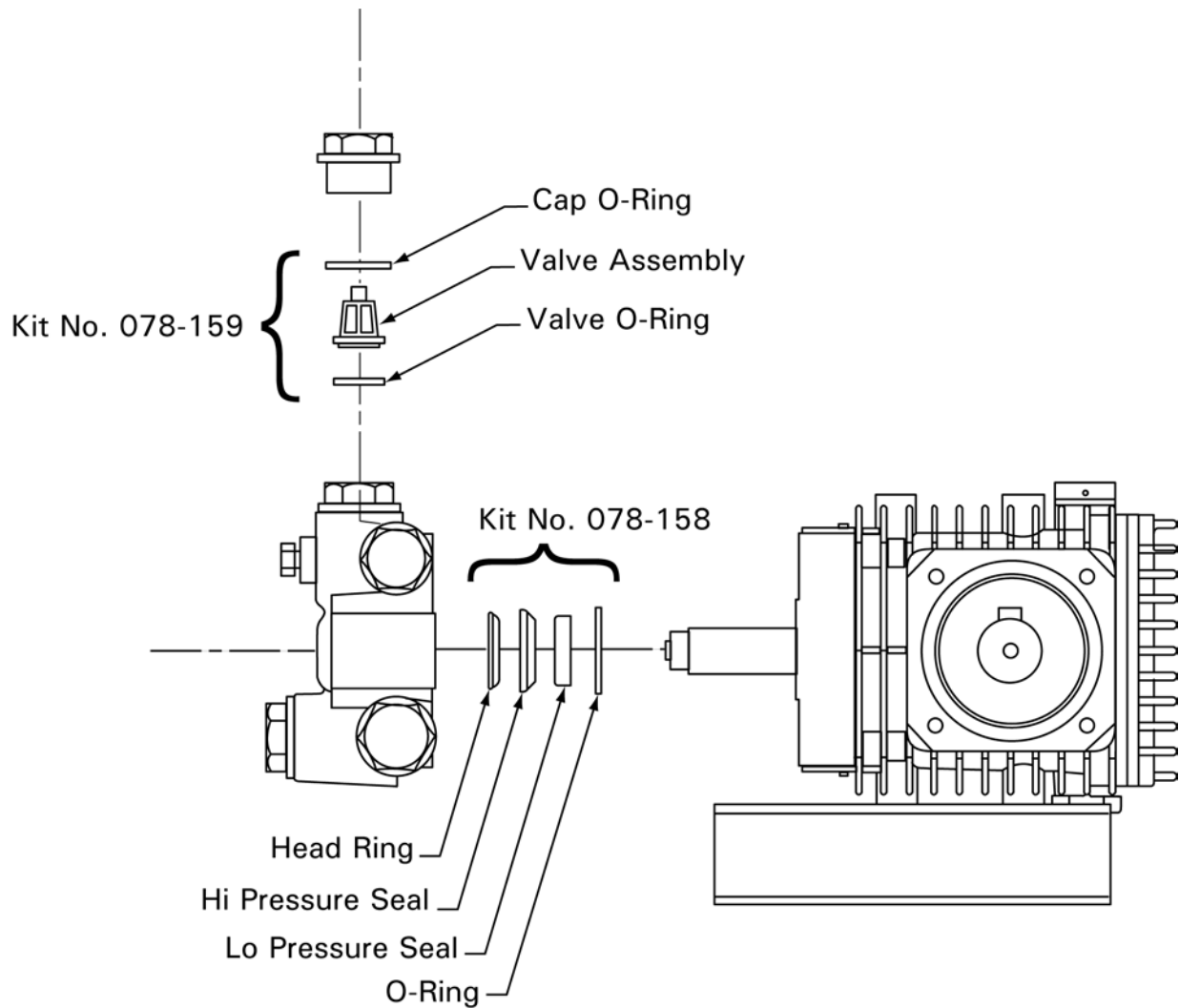
The next few pages explain how to disassemble and inspect all easily serviceable parts of the pump.

**CAUTION**

Do not disassemble the hydraulic end unless you are a skilled mechanic. For assistance, contact the distributor in your area.

**Servicing the Valves (See Figure 5-1)**

1. Remove the hex valve plugs:  
Top — discharge  
Bottom — inlet



**Figure 5-1. Service the Valves**

2. Unthread the valve plug and examine the O-ring under the plug for cuts or distortion. Replace it if it is worn. Lubricate new O-rings before installing.
3. Grasp the valve retainer by the tab at the top with needle-nose pliers, then remove the O-ring at the bottom of the valve chamber.
4. Inspect all valve parts for pitting, gouges, or wear. If wear is excessive, replace valve assembly.
5. Re-install valve assemblies:
  - a. Using a clean towel, clean the valve chamber.
  - b. Install the O-ring into the high pressure manifold.
  - c. Install the valve assemblies into the high pressure manifold (the metal side of the valve faces the manifold).
  - d. Replace the O-ring on the hex valve plug.
  - e. Torque the plug to 30 ft lbs.

#### Removing the High Pressure Manifold

1. Using an M6 Allen wrench, remove all eight of the socket head bolts.
2. Rotate the crankshaft by hand to start separation of the manifold head from the crankshaft.
3. Insert two flat-head screwdrivers on opposite sides to further separate the manifold from the crankshaft.

### **CAUTION**

To avoid damage to either plunger or seal, keep the manifold properly aligned with the ceramic plungers when removing it.

4. Remove the seal retainer from the manifold and inspect for wear.
5. Examine the ceramic plunger for cracks or scoring (refer to Servicing the Plungers for replacement).

**Servicing the Low Pressure Seals and High Pressure Seals (See Figure 5-1.)**

Remove the low pressure seal from the seal retainer using a 90 degree pick tool.

6. Remove the high pressure seal from the manifold
7. Inspect the low pressure seal and high pressure seal for wear and replace if necessary.
8. Re-install the low pressure seal into the seal retainers with the garter spring down.
9. Re-install the high pressure seal:
  - a. Lubricate the seal chamber in the manifold.
  - b. Carefully square the high pressure seal into position by hand, with the grooved side down (metal back facing out).
  - c. Examine the seal retainer's O-ring and replace if worn. Lubricate the new O-ring before installing.
  - d. Press the seal retainers into the manifold until completely seated.

**Servicing the Plungers**

1. Using a hex tool, loosen the plunger retainer about three to four turns. Push the back to separate it from the retainer and finish unthreading the plunger retainer by hand.
2. Unthread the plunger retainer with sealing washer.
3. Remove the ceramic plunger, keyhole washer and barrier slinger from the plunger rod.

**Re-install the Ceramic Plungers:**

1. Examine the sealing washer on the plunger retainer and replace it if it is cut or worn. Lubricate the new sealing washer for ease of installation and to avoid damage.
2. Apply Loctite 242™ to the threads of the plunger retainer and press it into the ceramic plunger. Thread 'hand'-tight, then torque the bolt to 4.4 foot pounds.
3. Install the seal retainer with holes to the top and bottom, and forward.

**Re-install High Pressure Manifold**

1. Slip the seal retainer over the ceramic plungers with the holes to the top and bottom and forward.
2. Turn the shaft by hand to line up the plungers so that the end plungers are parallel.
3. Lightly lubricate the plungers and carefully slide the manifold head onto the plungers while supporting it from the underside to avoid damaging the plungers.
4. Re-install the socket head bolts and torque to 4.4 foot pounds.

**Servicing the Crankcase**

1. While manifold, plungers, and seal retainers are removed, examine the crankcase seals for wear.
2. Rotate the crankshaft oil seal externally for drying, cracking or leaking.
3. Consult your HydraMaster distributor if crankcase servicing is necessary.

## VACUUM SYSTEM

The vacuum pump in this machine is commonly referred to as a 'positive displacement lobe' type blower. The performance and life of this unit is greatly dependent on the care and proper maintenance it receives.

Because of the close tolerances between the lobes and housing of the vacuum blower, solid objects entering the inlet will damage the internal lobes, gears, bearings or drive system.

To prevent this, a stainless steel filter screen has been placed at the vacuum inlet inside the vacuum recovery tank.

### **▲ WARNING**

Caution should be used when machine is being run for test purposes and the vacuum inlet on top of the machine is open. Running the equipment with the vacuum inlet open may cause bodily injury.

To protect the vacuum blower from overloading and damaging itself, a vacuum relief system has been installed on the blower collector box. When the vacuum tank inlet is completely sealed off, a maximum of 14" Hg will be attained.

At the end of each day the internal components of the blower need to be lubricated. This helps to prevent rust deposits and prolongs the life of the truckmount.

To lubricate the blower:

1. Allow the unit to run for a few minutes with the vacuum hose disconnected in order to remove moisture from the blower.
2. Cap off the inlet(s) to the vacuum tank.
3. Spray a HydraMaster-recommended spray lubricant into the "BLOWER LUBE PORT" for about 5 to 10 seconds while the unit is running.
4. Uncap the inlet(s) and run the unit for another minute to allow the blower to cool down.

### **CAUTION**

It is important to keep the vacuum recovery tank foam free. Foam passing through the blower could lead to serious problems.

Read the vacuum blower manual carefully for proper oil change. The maintenance log may differ slightly from the manual, but the carpet cleaning application is very demanding of the vacuum blower and therefore the blower should be maintained more regularly.

**NOTICE**

The vacuum recovery tank is protected from overflowing by a vacuum recovery tank float kill switch. The switch is not activated by foam, only by liquid.

**DESCALING (AS REQUIRED)**

Scale deposits on the interior of the heating system can cause a noticeable loss in heating performance. Deposits of this kind result from hard water deposits, improper chemicals, etc. The frequency with which descaling procedures are required will vary. If your area has particularly hard water or you see evidence of deposits in the water system, you may have to descale monthly.

To descale your system:

1. Add an appropriate descaler chemical to your water box.
2. Circulate it through the heating system.
3. Let it stand. Flush and repeat as necessary.
4. Clean all screens and strainers, and check them frequently following descaling.

**NOTICE**

If you are using **T.M. DeScaler** through the flow meter, make sure to run clean water through the flow meter after this procedure.

To descale using the recirculation kit (P/N 000-078-058), start with an empty water tank.

1. Fill a third of the water box with **T.M. DeScaler**.
2. Follow the recommendations on the **T.M. DeScaler** label for proportions. Verify that the upper float is not lying horizontal, but floats below.
3. Attach the recirculation fitting provided in the kit to the garden hose quick connect (see illustration) and this combination to the front of the machine.
4. Attach one section of female/female solution hose to the outgoing solution fitting on the front of the machine and the other end to the garden hose and recirculation fitting combination that is attached to the front of the machine (or as many sections as you want, if you wish to descale your hoses).
5. Start the machine and allow it to run for 3 - 5 minutes. Do not leave the **T.M. DeScaler** solution in the system
6. Flush the system with clean water and turn the machine OFF.



## FREEZE GUARD

To freeze guard your machine:

1. Start the machine.
2. Spray all of the water out of the system until the engine stops.
3. Add a half gallon of 50/50 antifreeze and water mix to the chemical water box and draw the antifreeze into the flow meter.

**When using the recirculation kit (P/N 000-078-058)**, fill a third of the water box with a 50/50 antifreeze mix. Verify that the upper float is not lying horizontal, but floats below.

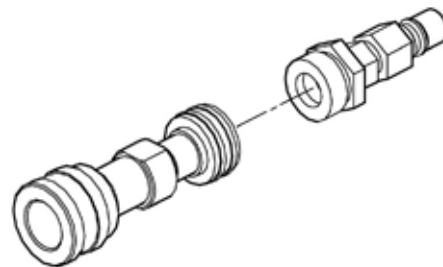
Attach the recirculation fitting provided in the kit to the garden hose quick connect (see Figure 5-2) and this combination to the front of the machine.

Attach one section of female/female solution hose to the outgoing solution fitting on the front of the machine and the other end to the garden hose and recirculation fitting combination that is attached to the front of the machine (or as many sections as you want, if you wish to freeze guard your hoses).

4. Start the machine. Allow it to run for 2 - 3 minutes.

**With the recirculation kit**, skip ahead to step 6.

5. Remove the quick connect fitting from the end of the garden hose. Attach the garden hose quick connect to the machine. Using a vacuum hose attached to the recovery tank, vacuum the water out of the garden hose quick connect.
6. Spray the antifreeze and water mix out of the machine and into a container to reclaim the solution. Run the machine until it stops.



**Figure 5-2. Recirculation Fitting**

### NOTICE

The reclaimed antifreeze solution may be used 3 times before being discarded.

### NOTICE

To freeze guard hoses and wand, perform the above step with all the hoses and wand attached.

The machine is now freeze guarded. Remember to flush antifreeze from the system prior to carpet cleaning.

### **Recovering Antifreeze For Reuse**

Before cleaning with the machine again, flush the remaining anti-freeze solution from the system into a sealable container so that it may be used again. To do this, spray water through the hoses and wand until all signs of antifreeze are gone.

#### **⚠ WARNING**

One manufacturer of antifreeze cautions: **“WHEN DISPOSING OF USED ANTIFREEZE COOLANT:** Follow local laws and regulations. If required, dispose at facilities licensed to accept household hazardous waste. If permitted, dispose in sanitary sewer systems. Do not discard into storm sewers, septic systems, or onto the ground.”

#### **⚠ WARNING**

This warning appears on the label of one brand of antifreeze: **“HARMFUL OR FATAL IF SWALLOWED.** Do not drink antifreeze coolant or solution. If swallowed, induce vomiting immediately. Call a physician. Contains Ethylene Glycol which caused birth defects in animal studies. Do not store in open or unlabeled containers.

#### **⚠ WARNING**

KEEP OUT OF REACH OF CHILDREN AND ANIMALS.

### **Freeze Protecting the Pump-In System**

1. Drain the fresh water tank.
2. Remove the garden hose adapter from the pump-in pump hose and position the hose so it is pointing outside the van.
3. Turn on the pump-in pump and run for 1-2 minutes till all the water is purged from the hose.

#### **NOTICE**

The next time the unit is used, it may take a few minutes before the water box begins to fill.

# 6 - Water and Chemical System

This high pressure chemical system has been designed to be simple and trouble free.

## **WATER AND CHEMICAL FLOW OPERATION**

The chemical pump draws the chemical from the inlet filter which is in the chemical container. It flows through the flow meter indicating the gph's of chemical being used. The chemical then flows through the chemical pump to the chemical selector valve. The chemical valve can be used to prime the pump (evacuate air from the system), inject chemical into the system or turn the chemical flow off. In the "ON" position, chemical flows through the metering valve, and is injected into the heated water path just prior to its leaving the machine.

The low water float switch in the water box, is a safety switch that is designed to protect your system from sudden or unexpected loss of water supply. If, for example, the water source at the house were turned off, the water level of the water box would drop, activating the low water float switch, which automatically disengages the system and prevents the water pump from running dry.

The desired chemical injection ratio may be obtained by an adjustment of the chemical flowmeter during the spraying of water through the cleaning tool.

## **BEFORE CLEANING**

1. Turn the Chemical Selector Valve to the "PRIME" position to purge any air from the system. If the chemical does not begin to flow through the flowmeter within 60 seconds, remove the Chemical PRIME Line (the one without the filter) from the chemical container and insert it into the vacuum hose connection at the front of the machine.
2. When the chemical begins to flow through the flowmeter, with the flow indicator indicating maximum flow and the PRIME line pulsing, turn the Chemical Selector Valve to "ON".
3. Place the Chemical PRIME Line back into the chemical container.
4. While spraying solution from the cleaning tool, adjust the chemical flow by turning the Chemical Adjustment Knob as necessary.



## **CHEMICAL SYSTEM MAINTENANCE**

The chemical lines may need to be flushed with vinegar periodically to prevent abnormal chemical build-up.

Flush the lines by:

1. Setting the chemical flowmeter to 10 gph.
2. Removing the clear plastic hose from the chemical jug and inserting it into a one quart container of vinegar. Simply spray water from the wand until the quart of vinegar is exhausted.
3. Repeating the process with one quart of clear water to void all lines of vinegar.

## TROUBLESHOOTING

### Heating System

#### 1.0. Machine overheats and shuts down

1.1.	One or both orifices or filter screens are restricted.	Remove and inspect. Clean as necessary. Note: Make sure orifices are not interchanged.
1.2.	High pressure dump solenoid is restricted.	Inspect solenoid and the hose that delivers water to it. Clean or replace as necessary.
1.3.	Diverter valve is stuck or out of adjustment.	Operate diverter valve manually (make sure exhaust system is cool) to determine if the movement of the valve is restricted. Repair or adjust as necessary.
1.4.	Diverter valve and high-pressure dump solenoid are not functioning.	Check the fuses that provides power to the diverter mode relay and to the temperature controller.
		If a fuse is blown, inspect electrical system for worn and shorted wires. Repair or replace as necessary.
		If fuse is good, inspect diverter relay and diverter switch. If either is faulty, replace.
		If switch and relay are good, refer to qualified service technician to test temperature controller and RTD sensor.
1.5.	Engine RPM is too high.	Check RPM with accurate tachometer and adjust as necessary to 3,000 RPM

2.0. Unable to achieve normal cleaning solution temperature

2.1.	System is in Divert mode or temperature control knob is turned down.	Inspect divert switch and temperature control. Change or adjust.
2.2.	Diverter valve is not closing completely.	Inspect diverter valve for proper operation. Adjust linkage as necessary.
2.3.	Diverter and hot water dump systems will not switch into "Cleaning" mode.	Refer to qualified service technician to test system.
2.4.	Engine RPM is too low.	Check RPM with accurate tachometer and adjust as necessary to 3000 RPM.
2.5.	Cleaning solution flow is too great.	Measure flow at cleaning tool.
		Cleaning tool jet is too large or worn out. Inspect jet. Replace if necessary.
		Cleaning solution pressure is too high. Adjust pressure to normal. Inspect pressure gauge for accurate reading.
2.6.	Heat exchangers have hard water scale build up internally.	Descale system.

## Chemical System

### 1.0. System will not prime

1.1.	Check valves in chemical pump are faulty.	Remove valves and inspect. Clean or replace as necessary.
1.2.	Chemical pump diaphragm is faulty. Remove and inspect.	Replace as necessary.
1.3.	Check valve in high pressure pump (the one that the chemical pump attaches to) is faulty.	Remove valve and inspect. Clean or replace as necessary.
1.4.	Filter on feed line in chemical jug is clogged.	Inspect and clean.
1.5.	Feed line from chemical jug is loose, pinched or cut.	Inspect and repair.
1.6.	Three-way prime valve is faulty. Inspect valve for leaks between ports.	Replace as necessary. Note: if the chemical system has been run dry, it is frequently necessary to insert the prime hose from the chemical jug into the vacuum inlet for a "boost" to purge all of the air from the system.

### 2.0. Chemical flow is unstable or low

2.1.	Air in lines. Check that all fittings and connections are tight and in good condition.	Repair or replace as necessary.
2.2.	Filter screen in chemical jug is partially clogged.	Inspect and clean.
2.3.	Three-way chemical valve is faulty. Inspect valve for leaks between ports.	Replace as necessary.

**Figure 6-1. Flow Diagram - View 1 of 3**  
5150

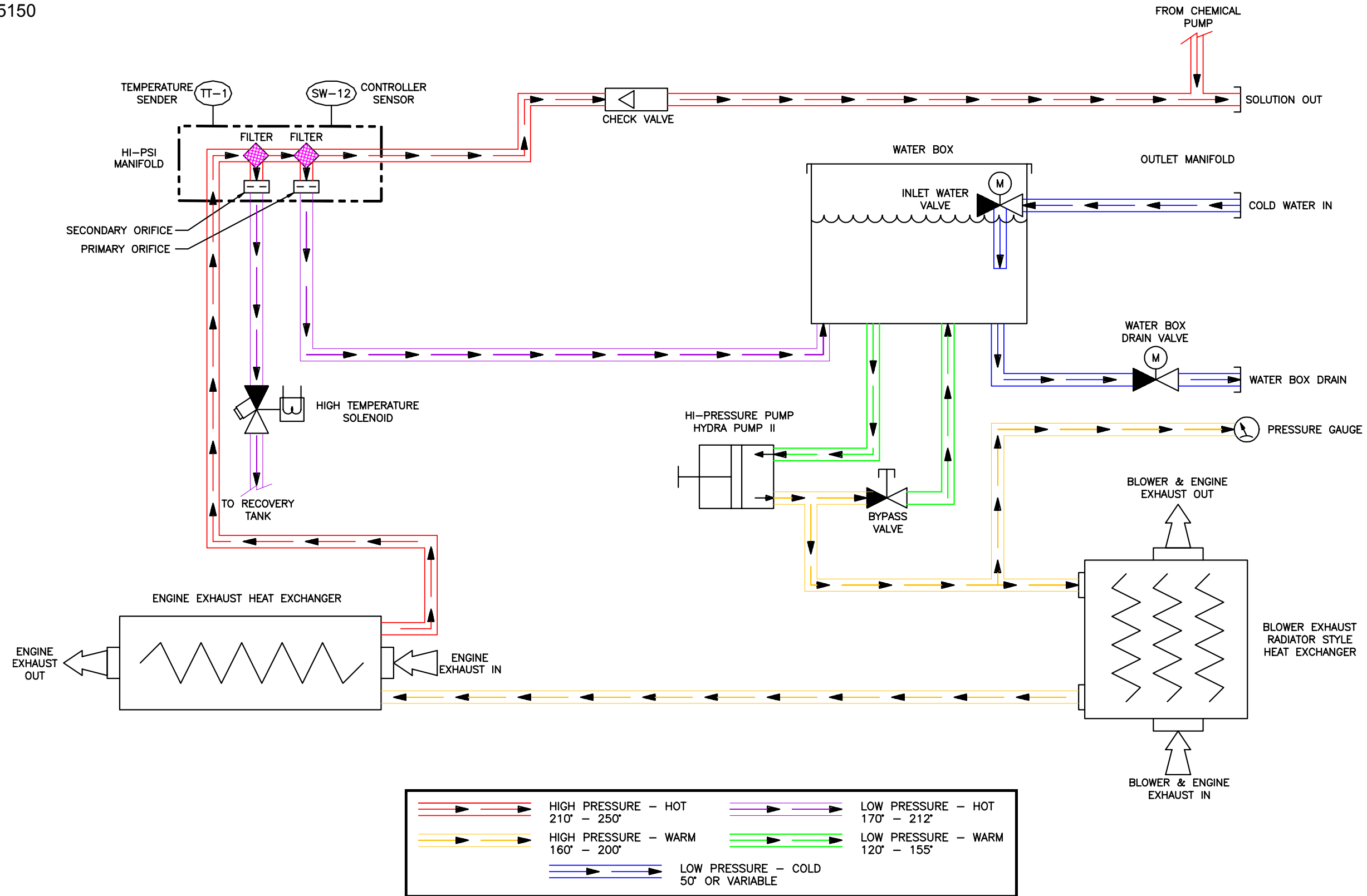
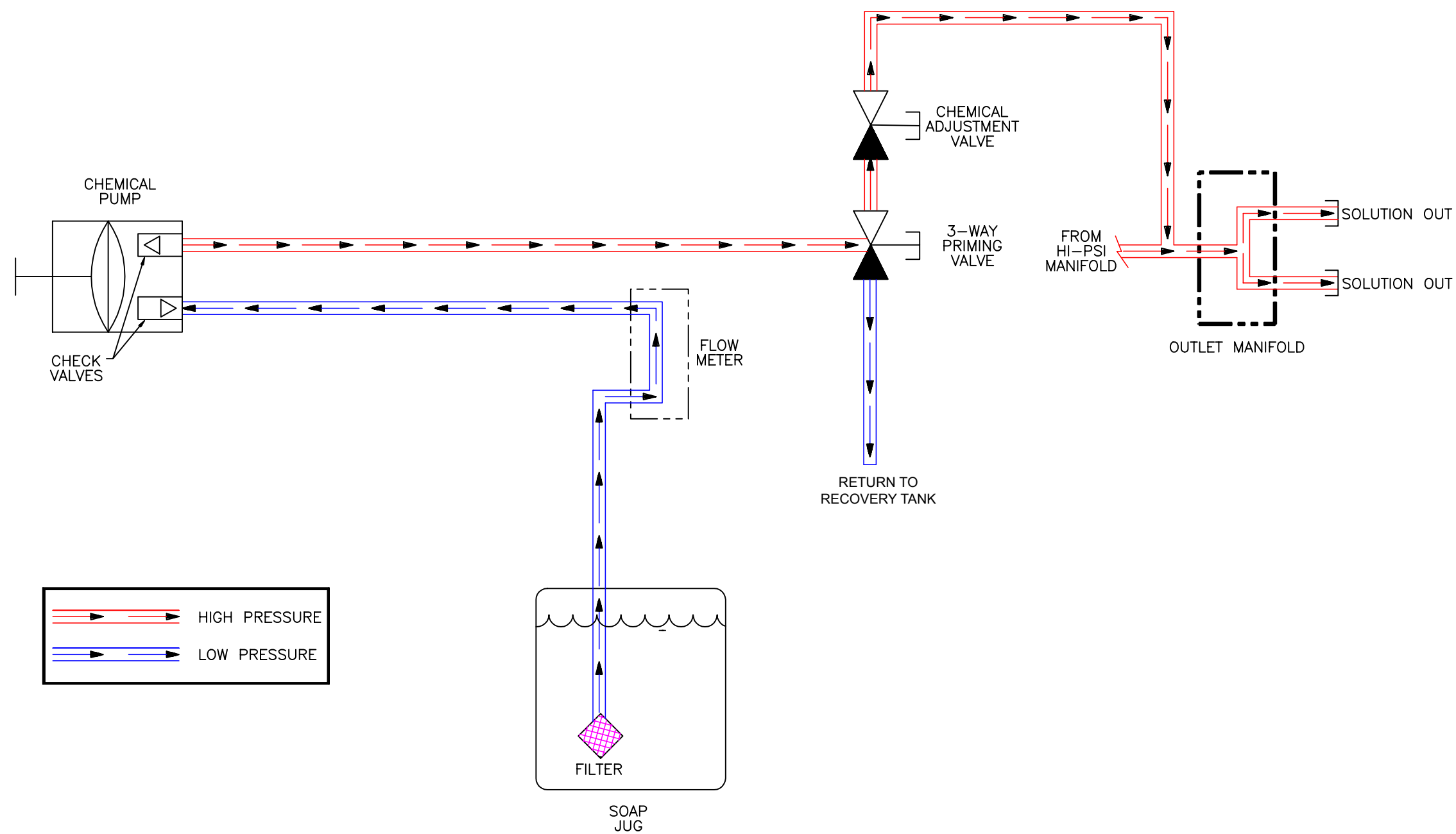
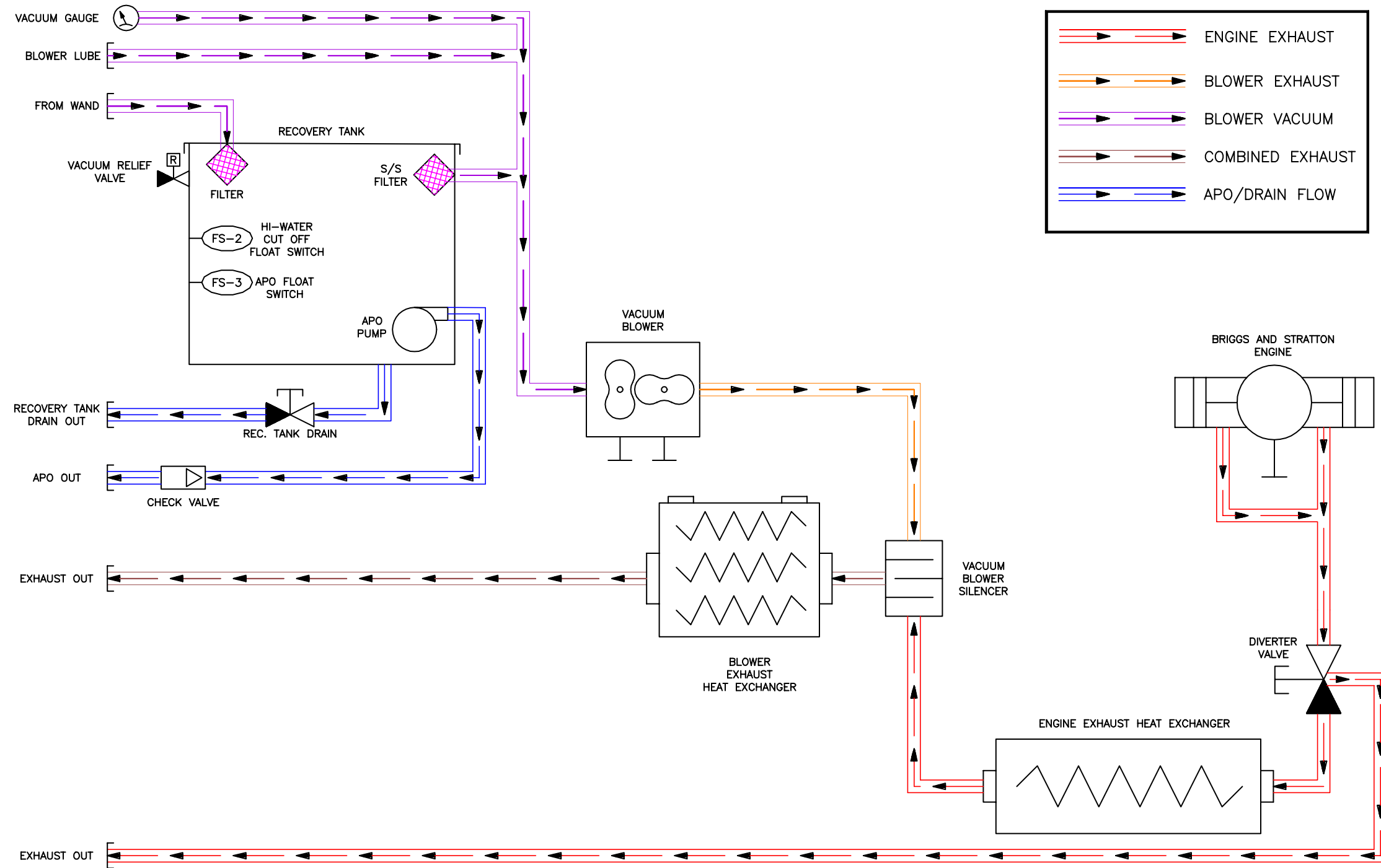




Figure 6-2. Flow Diagram - View 2 of 3  
5150



**Figure 6-3. Flow Diagram - View 3 of 3**  
5150



# 7 - Electrical System

The Boxxer 421 electrical system has been designed to ensure that any necessary troubleshooting is as easy as possible.

The entire electrical system operates on 12V DC which is provided by a battery. Battery levels are sustained by a 16 Amp alternator inside the engine.

## CAUTION

When a new battery is installed, check that it is properly charged before installation or damage to the charging regulator may occur.

### TROUBLESHOOTING

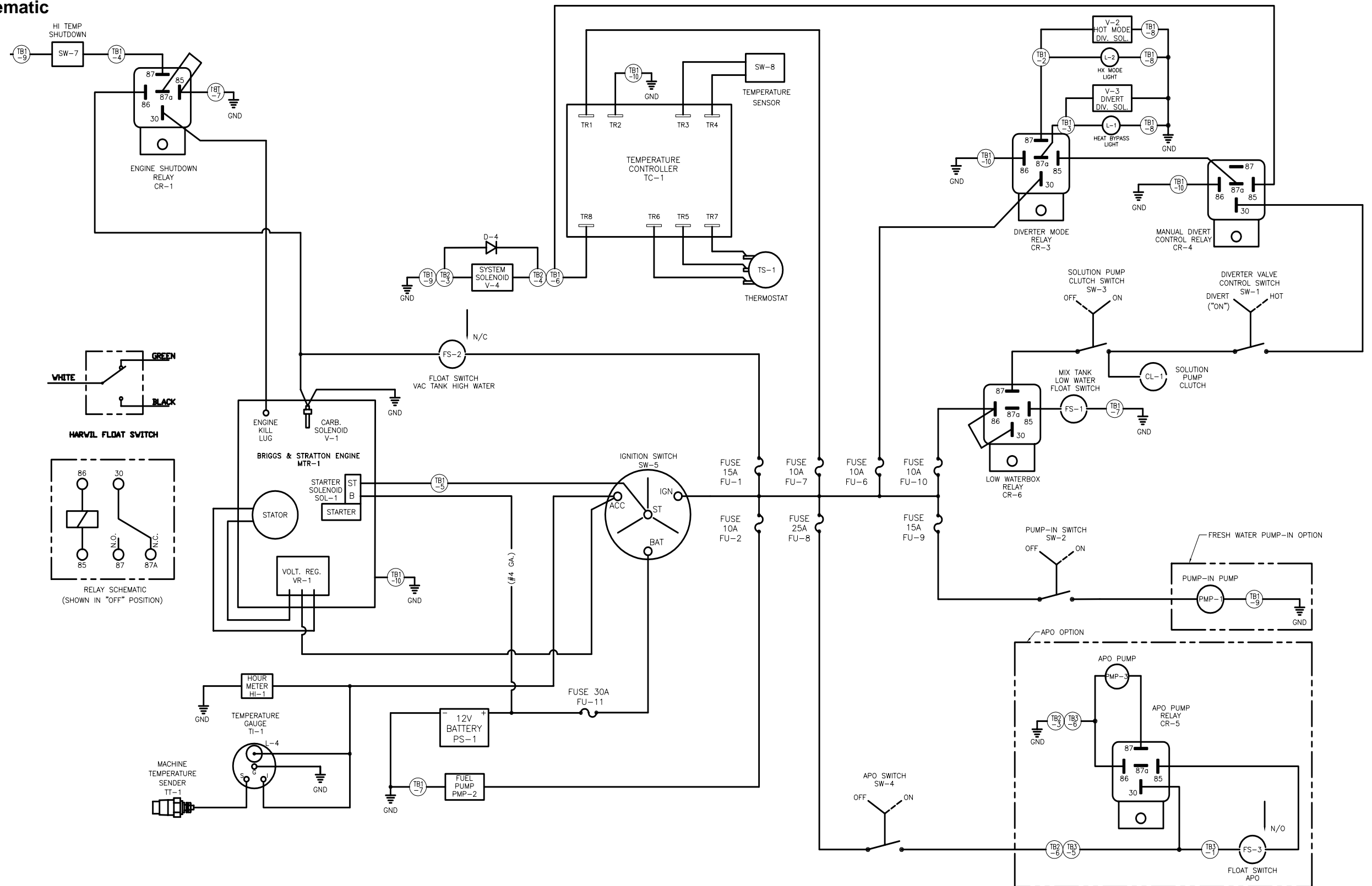
#### 1.0 The engine is not charging the battery.

1.1	The regulator/rectifier is bad.	Check the B+ voltage from the regulator/rectifier to ground. With the engine running at normal RPM the voltage should be 12.5 to 14.5 DC V. If necessary, replace the regulator/rectifier.
1.2	The stator winding is bad.	Check for AC voltage at the regulator/rectifier. The stator should be producing an AC voltage of around 25 to 40V.

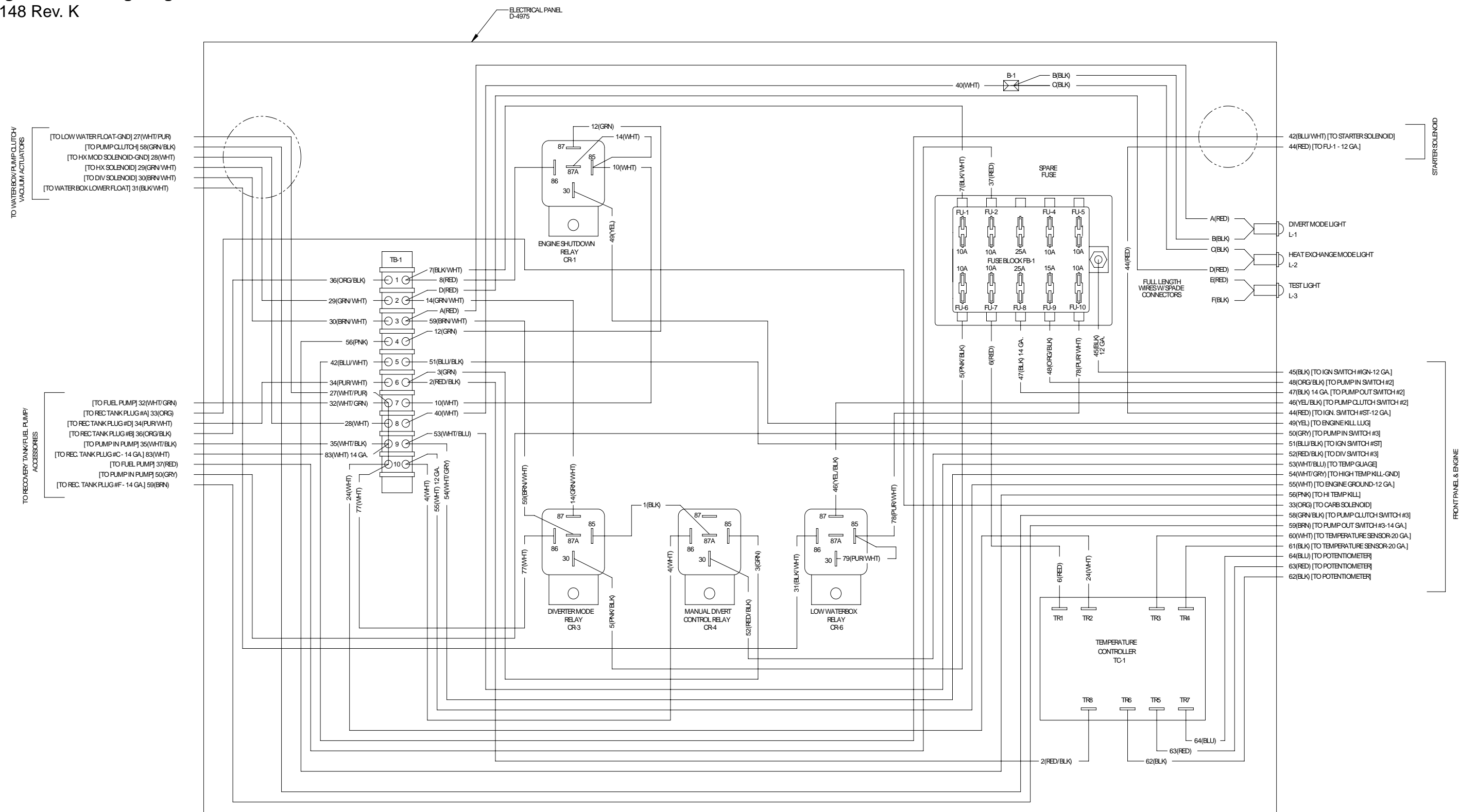
#### 2.0 The fuse is blown.

2.1	There is an electrical short.	Check for a loose wire or an uninsulated wire which is shorting out to ground. Unscrew each individual wire (except the white wires) one at a time until the fuse does not trip. Then trace that circuit.
-----	-------------------------------	---

**Figure 7-1. Electrical Schematic**  
5149 Rev. H

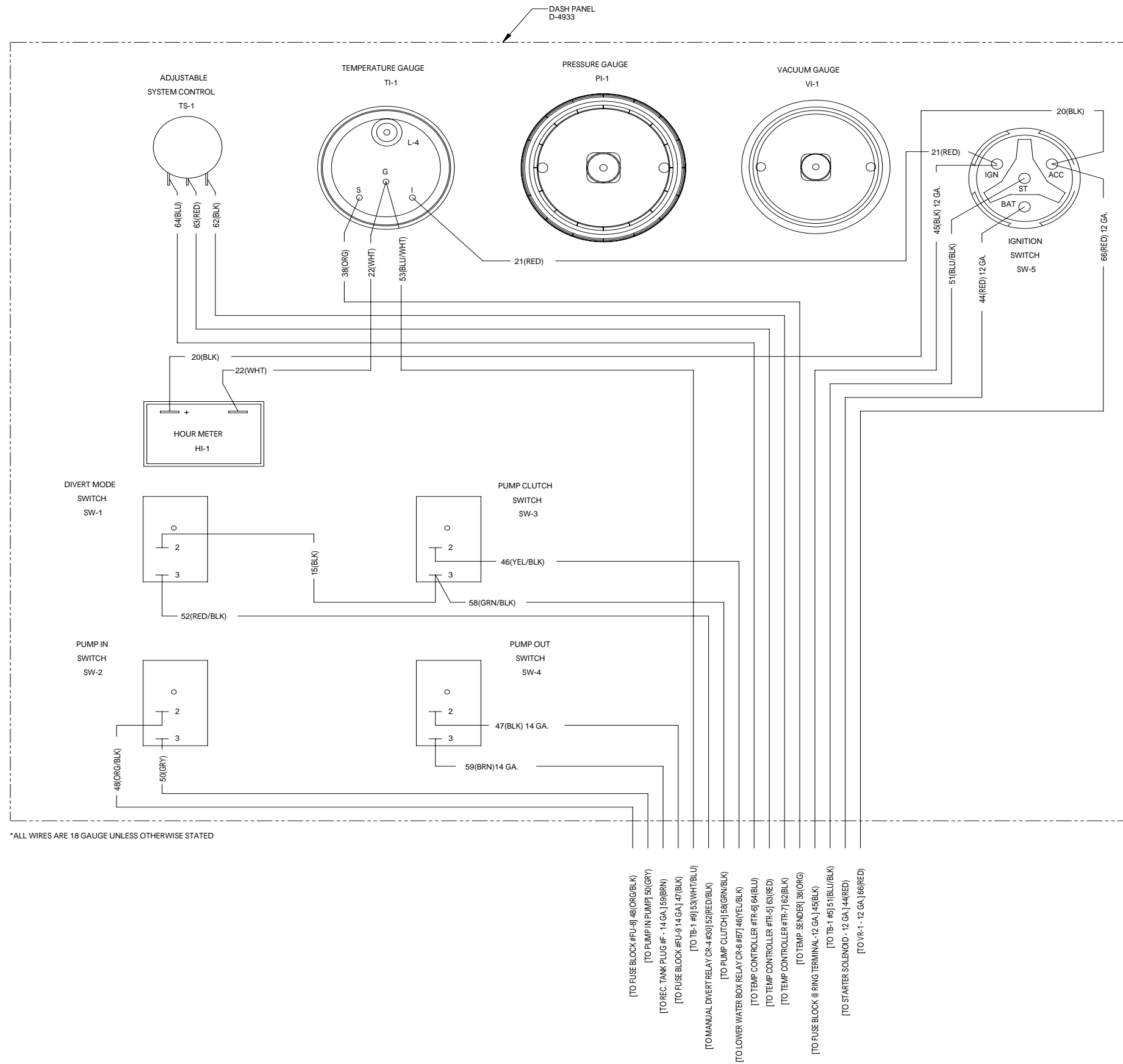


**Figure 7-2. Wiring Diagram - View 1 of 3**  
5148 Rev. K

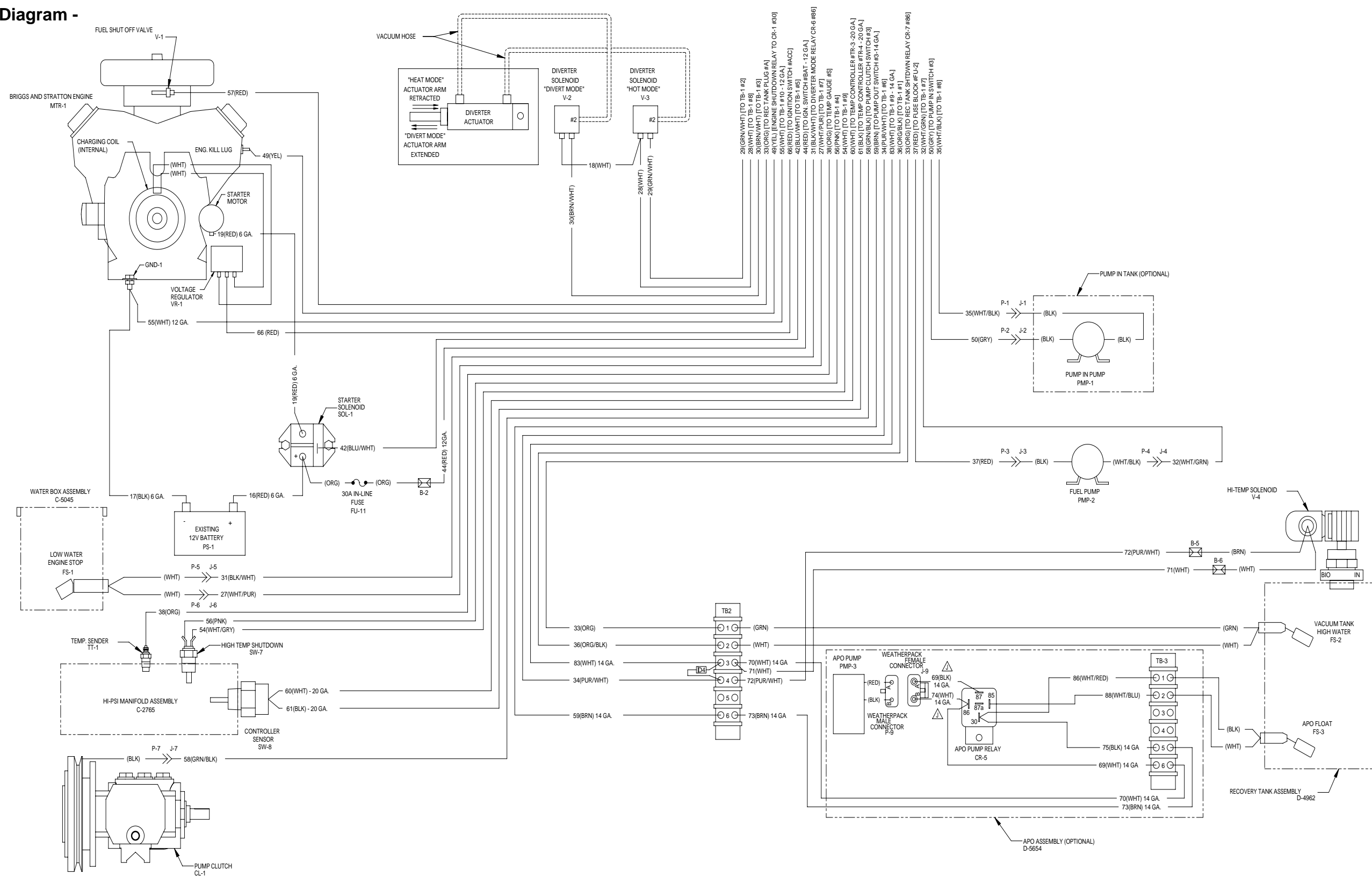


\*ALL WIRES ARE 18 GAUGE UNLESS OTHERWISE STATED

**Figure 7-3. Wiring  
Diagram - View 2 of 3**  
5148 Rev. K



**Figure 7-4. Wiring Diagram -  
View 3 of 3  
5148 Rev. K**







# 8 - Systems Troubleshooting

## ENGINE

### 1.0. Will not turn over

1.1.	There is a loose or corroded battery terminal.	Clean and tighten the battery terminal connections.
1.2.	The battery is dead. Recharge or replace the battery. Test the charging system.	Repair if necessary.  <b>CAUTION</b>  Do not attempt to jump-start this machine from a running vehicle. The amperage output from an automobile will damage the charging system of the truckmount.
1.3.	The 30 Amp main power fuse in the electrical panel has blown.	Inspect the wiring thoroughly to locate shorted or damaged wires.
1.4.	The vacuum blower has seized.	Attempt to turn the engine by hand. If it will not turn, refer to Vacuum section, 5.0.
1.5.	The ignition switch is defective.	Test to see if there is 12V to the switch. If there is, but there is not 12V going from the switch, replace the switch.
1.6.	There is a problem with the starter solenoid.	If there are 12V at the battery connection and at the key switch connection with the key in the start position but there are not 12V on the starter connection of the solenoid, replace the solenoid.
1.7.	The starter motor is defective.	Check to see if the engine can be turned over by hand. If it can and if there are 12V from the starter solenoid to the starter, replace the starter.
1.8.	There is a mechanical problem with the engine.	If the engine can be turned over by hand and the vacuum blower is not locked, refer the engine to a qualified service technician to determine the cause of the problem.

**2.0. Turns over but will not start. There is no spark****NOTICE**

To check for spark, use the following procedure. Remove a spark plug from the engine. Attach the lead wire back onto the plug. Ground the threaded part of the spark plug to an unpainted engine surface. While holding the plug and wire assembly by the insulated wire, crank the engine over by turning the ignition switch to the “start” position. You should observe a blue spark between the two electrodes of the spark plug.

**⚠ WARNING**

This procedure should only be attempted by an experienced mechanic. If equipment is not handled properly, bodily injury can result from electric shock.

2.1.	Recovery tank is full.	Empty the tank.
2.2.	Recovery tank float is defective.	Disconnect float. If engine starts, replace the float.
2.3.	The high temperature switch has shut the engine down.	Observe the temperature gauge. If it is above the normal operating range (230° or above), allow the machine to cool down. If it will still not start, disconnect the high temp switch. If the machine then starts, replace the switch.
	.	If the machine starts after it has cooled down, refer to the Heating System section, 1.0
2.4.	The spark plugs are faulty.	Remove and inspect. Replace as necessary.
2.5.	The engine ignition system is malfunctioning.	Refer to a qualified engine service technician for inspection.

### 3.0. Turns over but will not start. There is spark.

3.1.	Fuel is not reaching the carburetor inlet.	Check the fuel pump. If the pump is working, inspect the fuel lines between the fuel source and the carburetor. Repair or replace any faulty parts as necessary.
		If the pump <i>is not</i> working, check for 12V and a ground at the pump.
		<p>If 12V <i>is not</i> present at the pump, check the wiring to the pump, including the fuse. Repair or replace as necessary.</p> <p><b>NOTICE</b></p> <p>If the fuse has blown, carefully inspect the wiring for a shorted or damaged wire. Repair immediately.</p>
		If 12V <i>is</i> present at the pump and the ground is good, replace the pump.
3.2.	The carburetor solenoid is malfunctioning.	Test for 12V and proper ground at solenoid. If both test okay, replace the solenoid.
3.3.	The engine is flooded.	<p>Wait for a few minutes and attempt to start with the choke open.</p> <p><b>NOTICE</b></p> <p>If the engine has been flooded, it may be necessary to remove and clean the spark plugs.</p>
3.4.	The spark plugs are dirty or worn.	Inspect and replace as necessary.
3.5.	There is a mechanical problem with the engine.	Have engine inspected by a qualified engine service technician.

**4.0. Will not come up to normal operating rpm**

4.1.	Throttle linkage is out of adjustment.	<p>Inspect for broken or loose linkage. Repair or replace as necessary and adjust to proper rpm.</p> <div style="background-color: #0070C0; color: white; padding: 5px; text-align: center; font-weight: bold; font-size: 1.2em;">NOTICE</div> <p>It is important to use an accurate tachometer to adjust engine speed to 3,000 rpm while it is under a vacuum load of between 10" Hg and 14" Hg. Too high or too low will cause severe damage to machine components.</p>
4.2.	There is excessive load on the engine due to the blower-to-recovery tank hose becoming delaminated.	Remove and inspect the inside of the hose. Replace as necessary.
4.3.	There is excessive back-pressure on the engine or blower exhaust.	Check for clogged blower heat exchanger.

**5.0. Runs rough at high speed**

5.1.	One or both spark plugs are defective.	Remove and inspect spark plugs. Replace as necessary.
5.2.	A spark plug wire is loose at the spark plug or has been damaged.	Inspect wire. Replace wire and coil as necessary.
5.3.	Low compression on one or both cylinders.	Check compression. If low, check valve adjustment. If incorrect, adjust to proper specs. This operation should be performed by a qualified service technician.
		If adjustment is okay, there is a possibility of burned valves, burned head gasket or worn cylinders. Refer to qualified engine service technician.
5.4.	Poor spark on one or both cylinders.	Refer to qualified engine service technician.

5.5.	Inadequate fuel supply to the carburetor.	Test the fuel volume at the carburetor by removing the fuel line from the carburetor inlet and placing the line in a metal container with a minimum capacity. Turn on the ignition switch to operate the fuel pump. The fuel flow volume should be 27 oz / minute. Check for clogged filter or obstructed fuel line.
		Also check to make sure the fuel pump is mounted vertically and is close to the fuel source. Repair as necessary.

**6.0. Runs rich (Black smoke)**

6.1.	Dirty air filter.	Inspect and replace as necessary.
6.2.	Choke is partially closed.	Inspect and adjust or repair as necessary.
6.3.	Excessive fuel to carburetor.	Insure that fuel pump is proper psi rating. A fuel pump with a psi rating in excess of that of the pump supplied with the machine could overpower the inlet valve in the carburetor, causing excessive fuel to be supplied to the carburetor.

**7.0. Engine overheats**

7.1.	Poor ventilation in vehicle.	All cargo area doors must be open for proper ventilation. Roof vents are strongly recommended for machines that are operated in hot climates. Any item that might restrict air flow to the machine such as other equipment or a solid divider should be moved or modified to permit proper air flow.
7.2.	Low engine oil level.	Check oil level and replenish as necessary.
7.3.	Engine rpm too high.	Check rpm with an accurate tachometer. Adjust as necessary to 3,000 rpm.
7.4.	Restricted engine or blower exhaust.	Disassemble exhaust components to locate restriction. Repair as necessary.

## HIGH PRESSURE PUMP

### 1.0. Will not come up to normal cleaning pressure

1.1.	Pressure adjusting valve is defective or dirty.	Disassemble valve. Repair or replace if necessary.
1.2.	Worn seals or valves in pump.	Test pump output volume directly from pump at normal running RPM. If volume is below manufacturers specifications, replace seals and inspect for defective valves.
1.3.	Pump RPM is too low.	Check engine RPM and adjust as necessary to 3,000 rpm. Check for loose pump belt. Adjust tension as necessary.
1.4.	High temperature dump solenoid is activated.	Refer to page 6-3, High pressure dump solenoid is restricted.
1.5.	Primary system control orifice is missing or loose.	Remove filter and inspect. Tighten or replace as necessary.
1.6.	Primary system control orifice has been exchanged with secondary (hot water dump) orifice.	Inspect and reverse as necessary.
1.7.	Primary orifice is worn.	Measure orifice size and replace as necessary.

### 2.0. No pressure reading on psi gauge

2.1.	Pump switch is not turned on.	Turn on switch
2.2.	No water in water box.	Refer to page 8-7, 5.0. Water box empty or fills slowly.
2.3.	Pump belt is broken.	Replace belt.
2.4.	Pump clutch is not activated. There is no water in water box.	Check system back to source to locate cause of interruption to water flow.
2.5.	Pump clutch is not activated. There is water in the water box.	Check for 12V at clutch. If 12V is present, replace clutch.
		If 12V is not present, check fuse that supplies power to the low-water relay. If fuse is good and there is 12V at the relay, check the low water switch in water box.
		If low water switch has no continuity when float is up, replace the switch. If switch is good, replace the low water relay.

### **3.0. PSI gauge reads normal; low pressure from wand**

3.1.	There is a restriction in the cleaning tool. Inspect tool jet and clean or replace as necessary.	Inspect any filters in the cleaning tool and clean or replace as necessary.
3.2.	There is a defective quick connect in the system.	Inspect each quick connect and replace as necessary.
3.3.	There is a restriction in one of the solution hoses.	Remove quick connects and inspect hoses. Clean or replace as necessary.
3.4.	There are hard water deposits restricting the system between the afterburner heat exchanger and the high-pressure solution connection at the front of the machine.	Descalc the machine. If this doesn't solve the problem, disassemble this portion of the system until the restriction is located.

### **4.0. Pressure pulsation**

4.1.	Water in the water box is too hot and is approaching boiling point.	Check temperature of water in the water box. If it is too high, refer to page 6-3, 1.0. Machine overheats and shuts down.
4.2.	There is an air leak between the water box outlet and the pump inlet.	Physically check all hoses and fittings for cuts, breaks, cracks or tightness. Repair as necessary.
4.3.	One of the intake or outlet valves in the high pressure pump is defective or is being held open by debris.	Remove each valve and inspect for correct operation.

### **5.0. Water box empty or fills slowly**

5.1.	There is a restriction in the water supply system.	Inspect the supply system from the source through the incoming quick connects.
5.2.	The float valve in the water box is defective.	If there is adequate water flow to the incoming valve in the water box, disassemble and inspect the valve. Repair or replace as necessary.

**6.0. Water box overflows**

6.1.	There is either debris caught in the valve or the valve seal is bad.	Disassemble valve and repair or replace as necessary.
6.2.	The float has absorbed water and has lost buoyancy.	Detach float and check to see if it will float to the surface. Replace as necessary.
6.3.	The float has come out of adjustment.	Re-adjust float as necessary.



## VACUUM

### **1.0. Weak vacuum at wand. Gauge reads normal (10” to 14” with hoses and wand attached)**

1.1.	Clogged hoses or wand tube.	Disconnect hoses and check carefully for an obstruction.
1.2.	Excessive length of hoses connected to machine.	Make sure machine is rated for the conditions under which it is being operated.

### **2.0. Vacuum gauge will not come up to 14” Hg**

2.1.	There is an air leak somewhere in the vacuum system.	Check vacuum relief valve for proper adjustment
		Carefully check all vacuum hoses for a cut or break.
		Check recovery tank lid gasket. Make sure recovery tank drain valve is fully closed.
2.2.	Vacuum blower is turning too slowly.	Check engine rpm. Adjust as necessary to 3,000 rpm.
2.3.	The vacuum gauge is defective.	Test gauge and replace as necessary.

### **3.0. Vacuum gauge reads too high with no hoses attached**

3.1.	Filter in recovery tank is clogged.	Remove and clean or replace as necessary.
3.2.	Hose from vacuum blower to recovery tank is collapsed internally.	Inspect and replace as necessary.

### **4.0. Noisy vacuum blower**

4.1.	Vacuum blower is low on oil.	Inspect oil level and replenish as necessary.
		<div style="background-color: #0070C0; color: white; padding: 5px; text-align: center;"><b>NOTICE</b></div> <p>Running vacuum blower low on oil can cause severe mechanical damage. If this situation occurs, it should be inspected by a qualified service technician.</p>
4.2.	Vacuum blower has internal damage.	Refer to qualified service technician.

**5.0. Vacuum blower is locked and will not turn.**

5.1.	The machine has been unused for a period on time and the blower was not properly lubricated when it was shut down, causing rust to build up on internal surfaces.	Spray penetrating oil into blower inlet and let sit for at least one hour. Then very carefully use pipe wrench on outer diameter of pulley on blower shaft and attempt to free up blower. Do not use wrench directly on blower shaft. If unable to free up blower in this manner, refer to qualified service technician.
5.2.	There is internal damage to the blower.	Refer to qualified service technician.

**6.0. Water from exhaust**

6.1.	The recovery tank has been filled with foam or overfilled with water.	Remove recovery tank lid and inspect. If full, drain tank then inspect high-level shutoff switch for proper operation. Clean or replace switch as necessary.
		If foam is observed in recovery tank, use defoamer on carpet being cleaned
6.2.	Condensation.	This will be more pronounced in cool weather and humid climates. Observe how long this condition persists after starting machine. If it is only until the machine warms up, it is normal.
6.3.	A heat exchanger is leaking.	Change the diverter mode switch back and forth between Divert and Heat Exchange mode. Observe which condition causes water to be expelled from exhaust.
		If water is expelled while switch is in Heat Exchange mode, the engine exhaust after burner heat exchanger is leaking internally. Remove and test. Replace as necessary. If water is expelled while switch is in Divert mode, the blower exhaust heat exchanger is leaking. Remove and test. Replace as necessary

## 9 - Assemblies and Parts Lists

This section contains major assemblies and parts lists associated with the Boxxer 421:

- Machine Assembly Parts List
- Frame Assembly Parts List
- Engine Assembly Parts List
- Dash Assembly Parts List
- Electrical Control Panel Assembly Parts List
- Blower Heat Exchanger Assembly Parts List
- Water Box Assembly Parts List
- Pump Assembly Parts List
- Chemical Pump Assembly
- Blower Assembly Parts List
- Vacuum Relief Valve (Collector Box) Assembly Parts List
- Exhaust Assembly Parts List
- Diverter Valve Actuator Assembly Parts List
- Hi PSI Manifold Assembly Parts List
- By-Pass Valve Assembly Parts List
- Chemical Jug Tray Assembly Parts List
- 70 Gallon Universal Recovery Tank Assembly Parts List
- 70 Gallon Universal Recovery Tank Cover Assembly Parts List
- 100 Gallon Universal Recovery Tank (URT) Assembly Parts List
- 100 Gallon Universal Recovery Tank (URT) Cover Assembly Parts List
- 85 Gallon Rotomolded Tank Assembly Parts List
- Hose Routings

Figure 9-1. Machine Assembly - View 1 of 5  
610-050-720

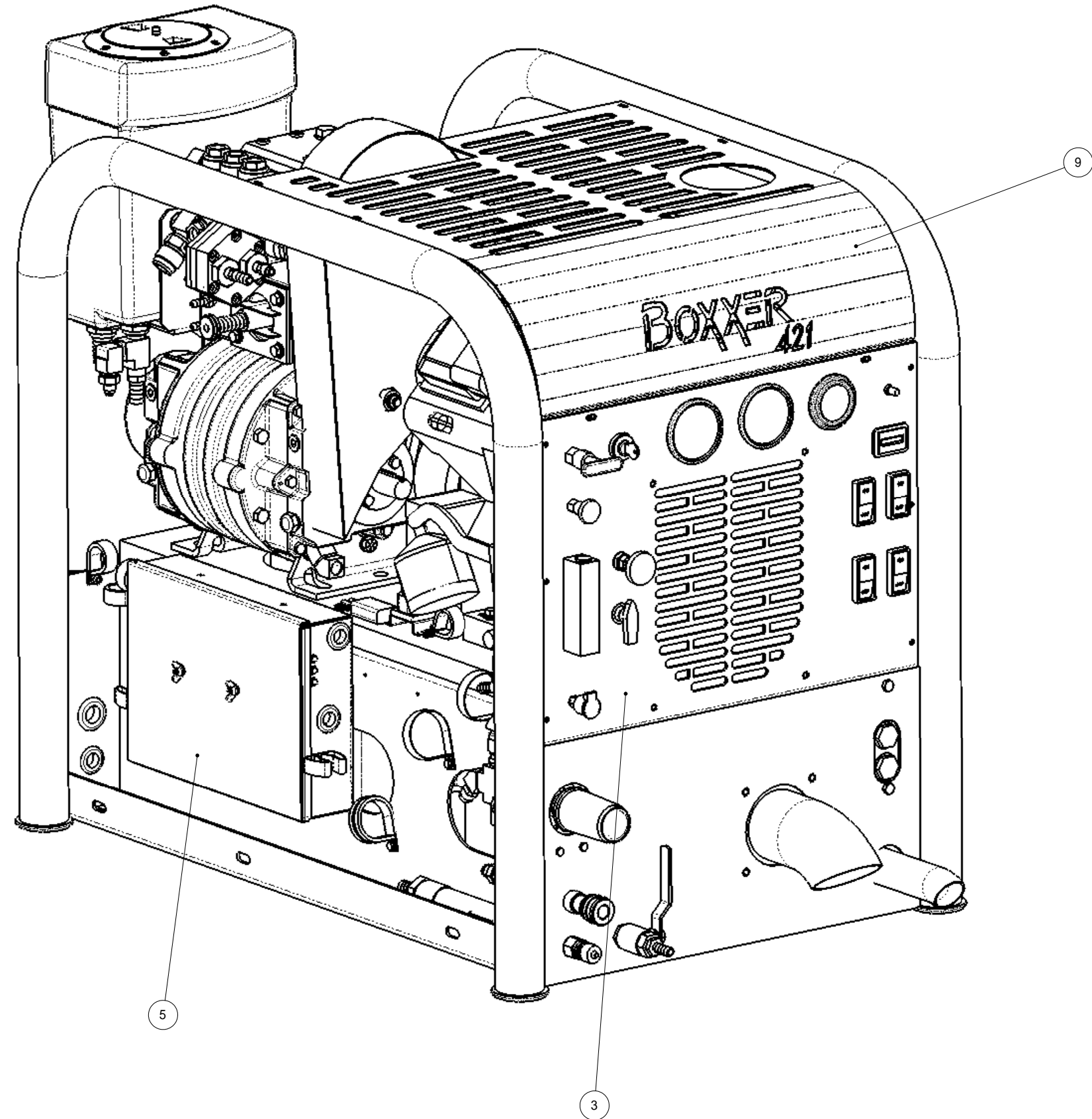
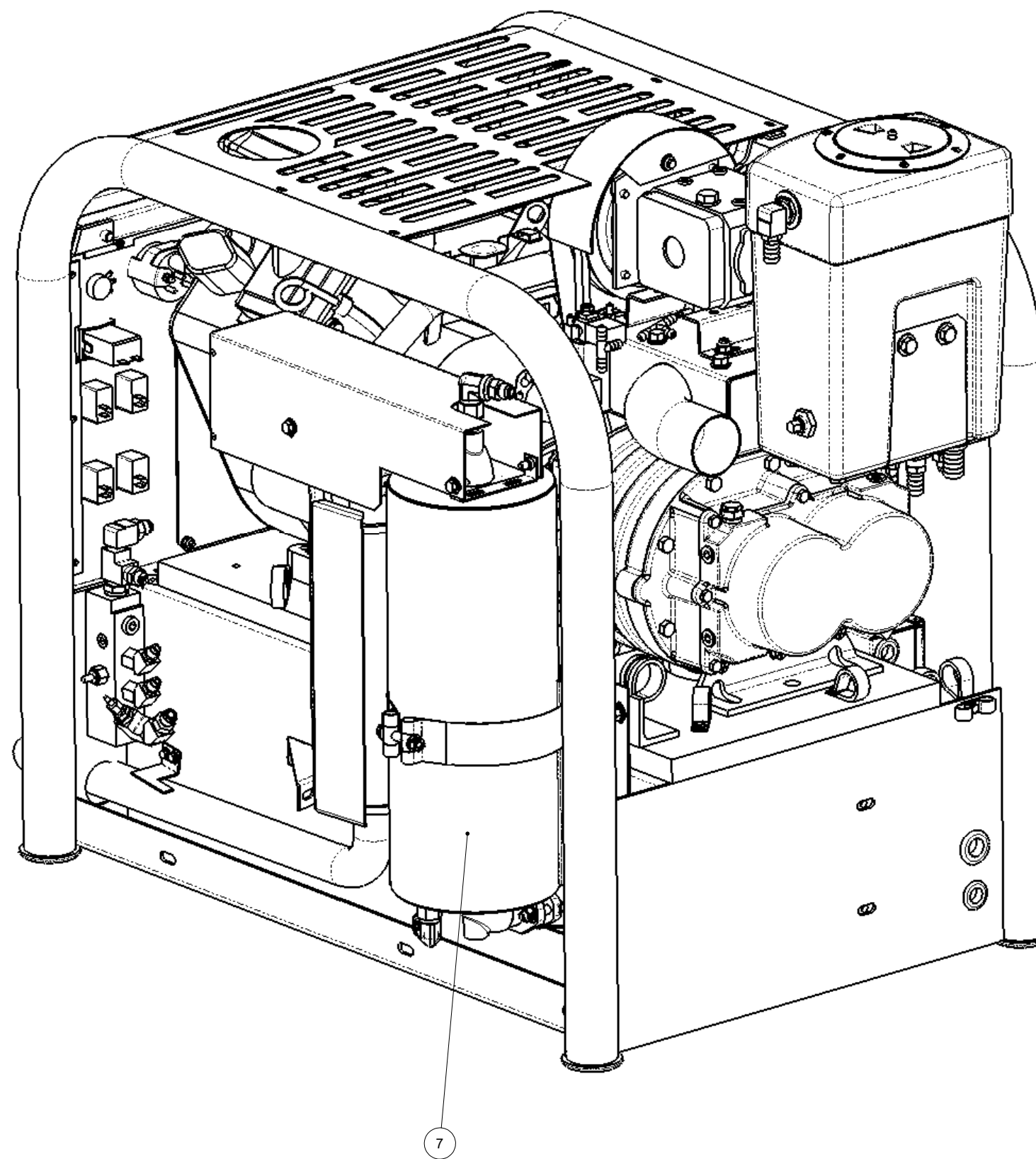


Figure 9-2. Machine Assembly - View 2 of 5  
610-050-720



**Figure 9-3. Machine Assembly - View 3 of 5**  
610-050-720

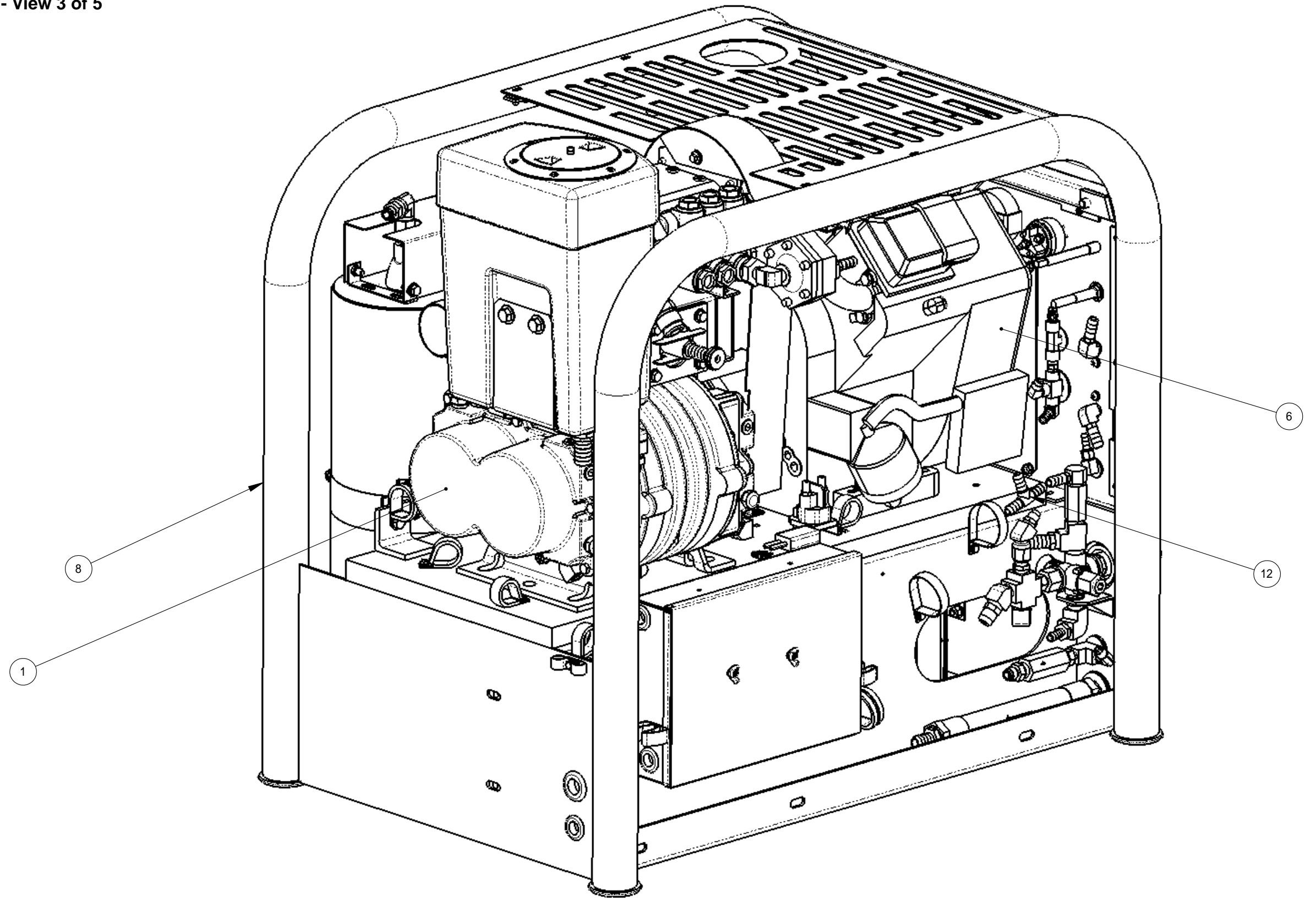


Figure 9-4. Machine Assembly - View 4 of 5  
610-050-720

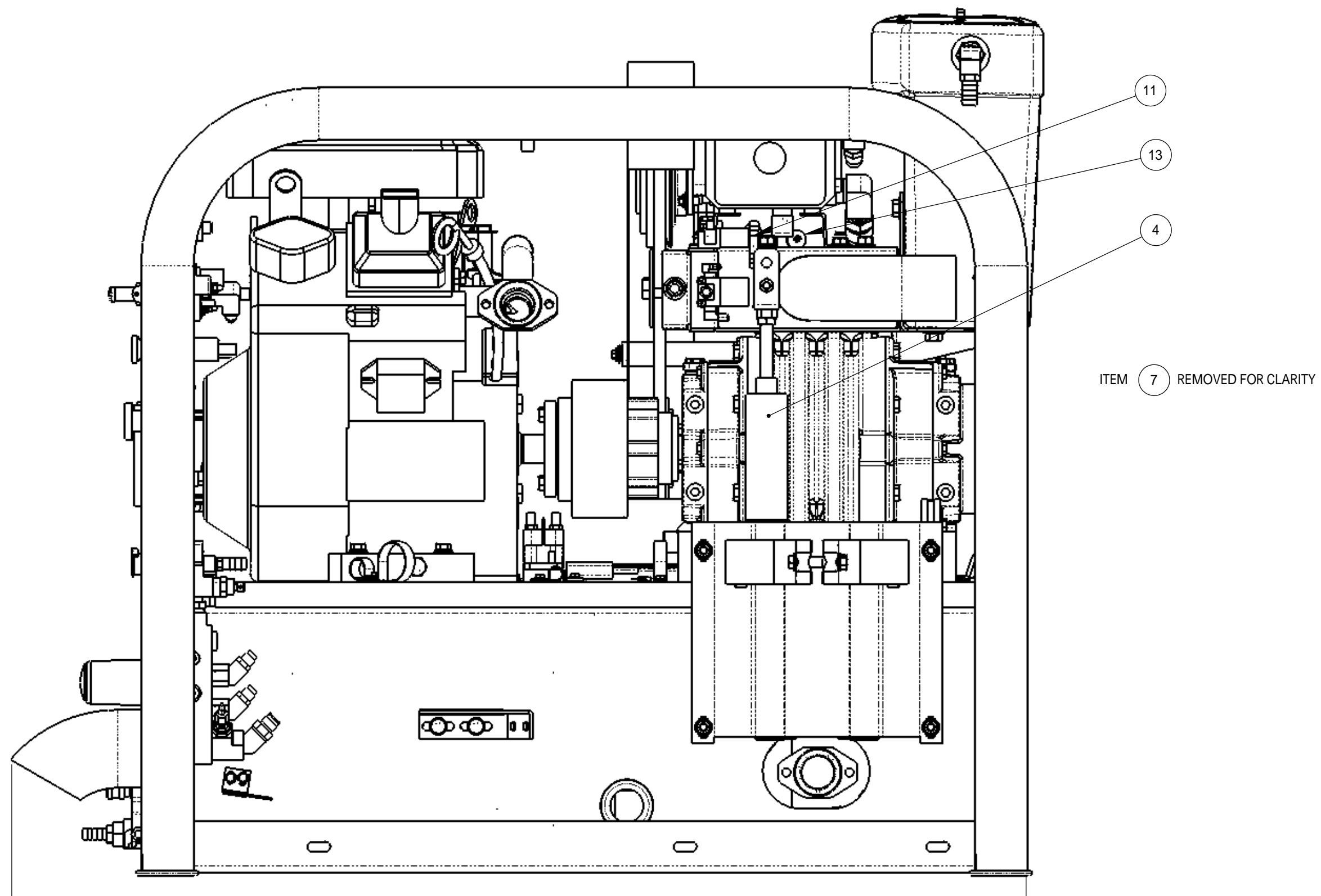
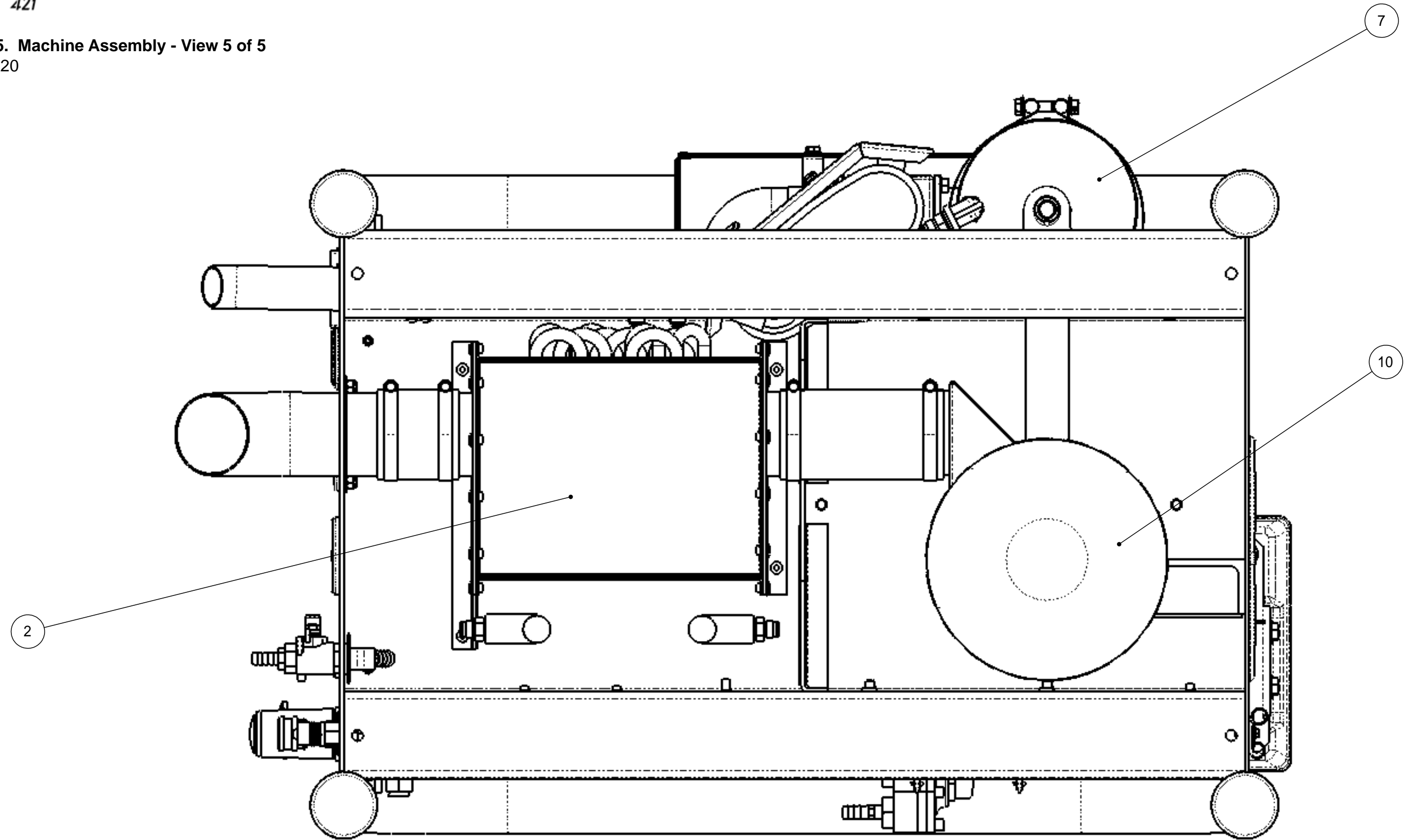




Figure 9-5. Machine Assembly - View 5 of 5  
610-050-720





**Machine Assembly Parts List**

Item	Part Number	Description	Qty
1	610-002-720	Assembly, Blower	1
2	610-005-720	Assembly, Blower Heat Exchanger	1
3	610-018-720	Assembly, Dash	1
4	610-014-720	Assembly, Diverter Valve Actuator	1
5	610-011-720	Assembly, Electrical Control Panel	1
6	610-004-720	Assembly, Engine	1
7	610-013-720	Assembly, Exhaust	1

Item	Part Number	Description	Qty
8	610-001-720	Assembly, Frame	1
9	000-041-385	Cover, Machine Top - Coated	1
10	000-093-080	Silencer, 3" Coated	1
11	000-052-156	Tee, 1/4" Plastic	2
12	000-052-022	Tee, 3/8" Insert	1
13	000-169-156	Valve, Check - Diverter Control	2

**Figure 9-6. Frame Assembly - View 1 of 3**  
610-001-720 Rev. K

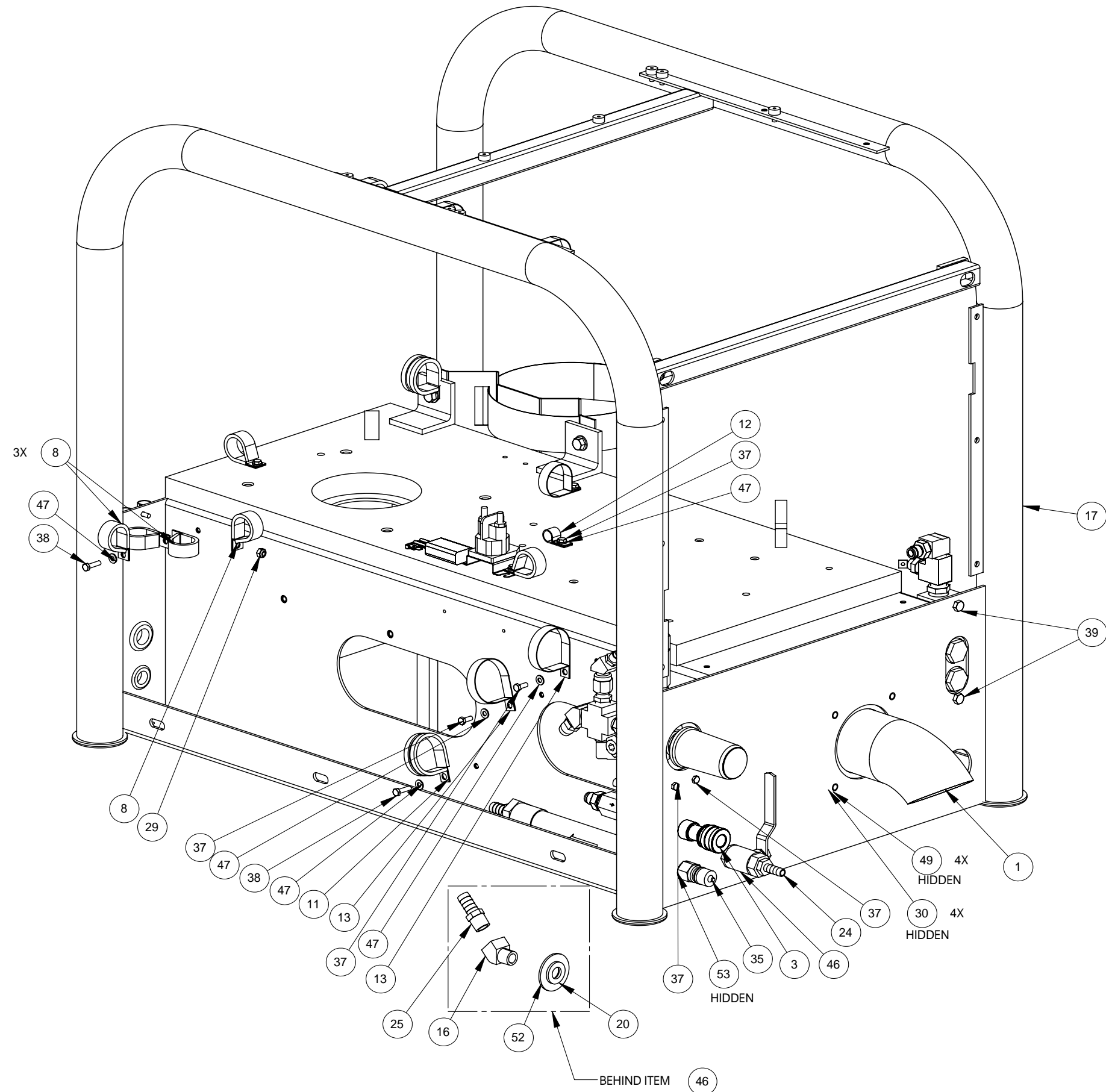
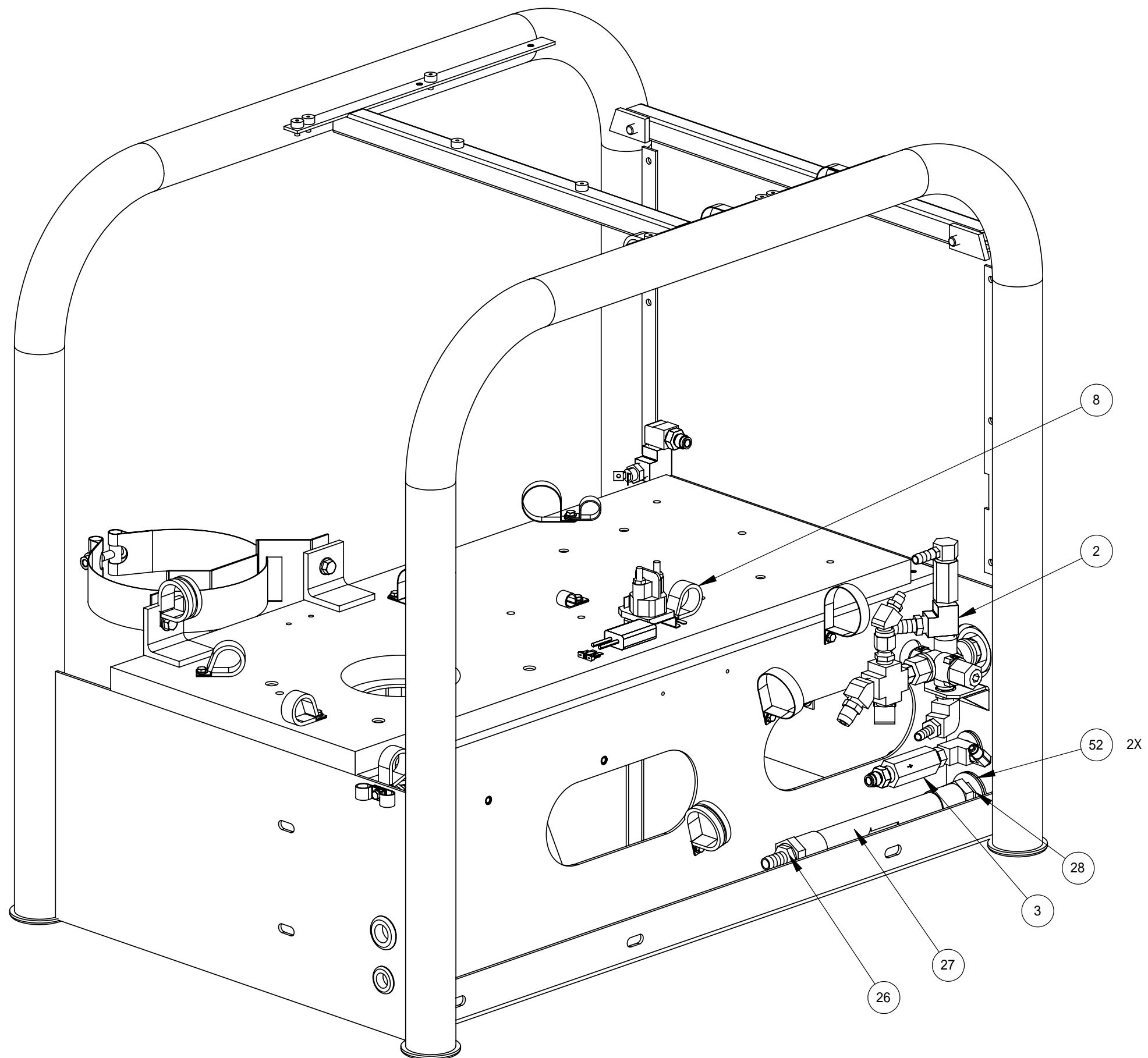
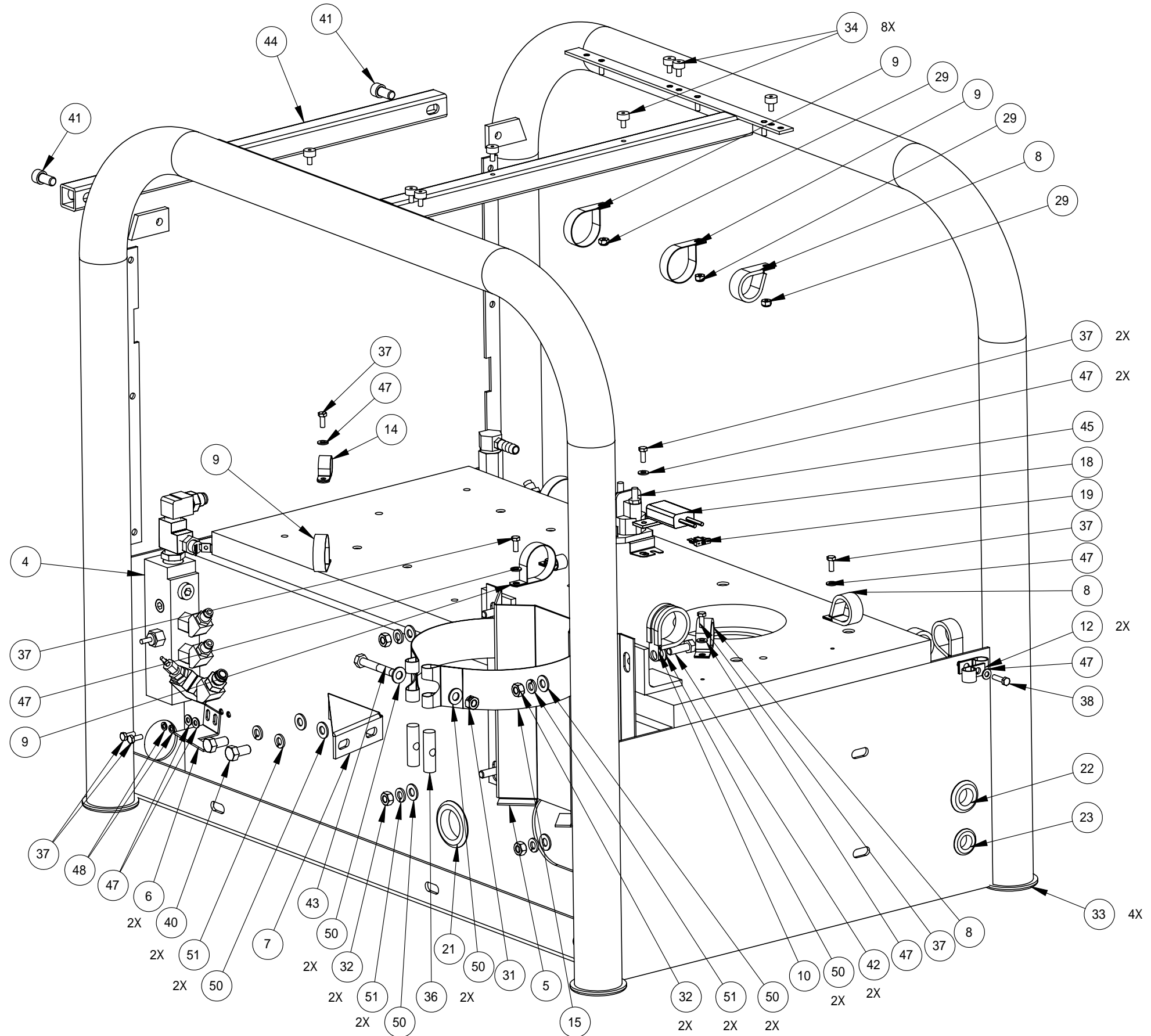


Figure 9-7. Frame Assembly - View 2 of 3  
610-001-720 Rev. K



**Figure 9-8. Frame Assembly - View 3 of 3**  
610-001-720 Rev. K

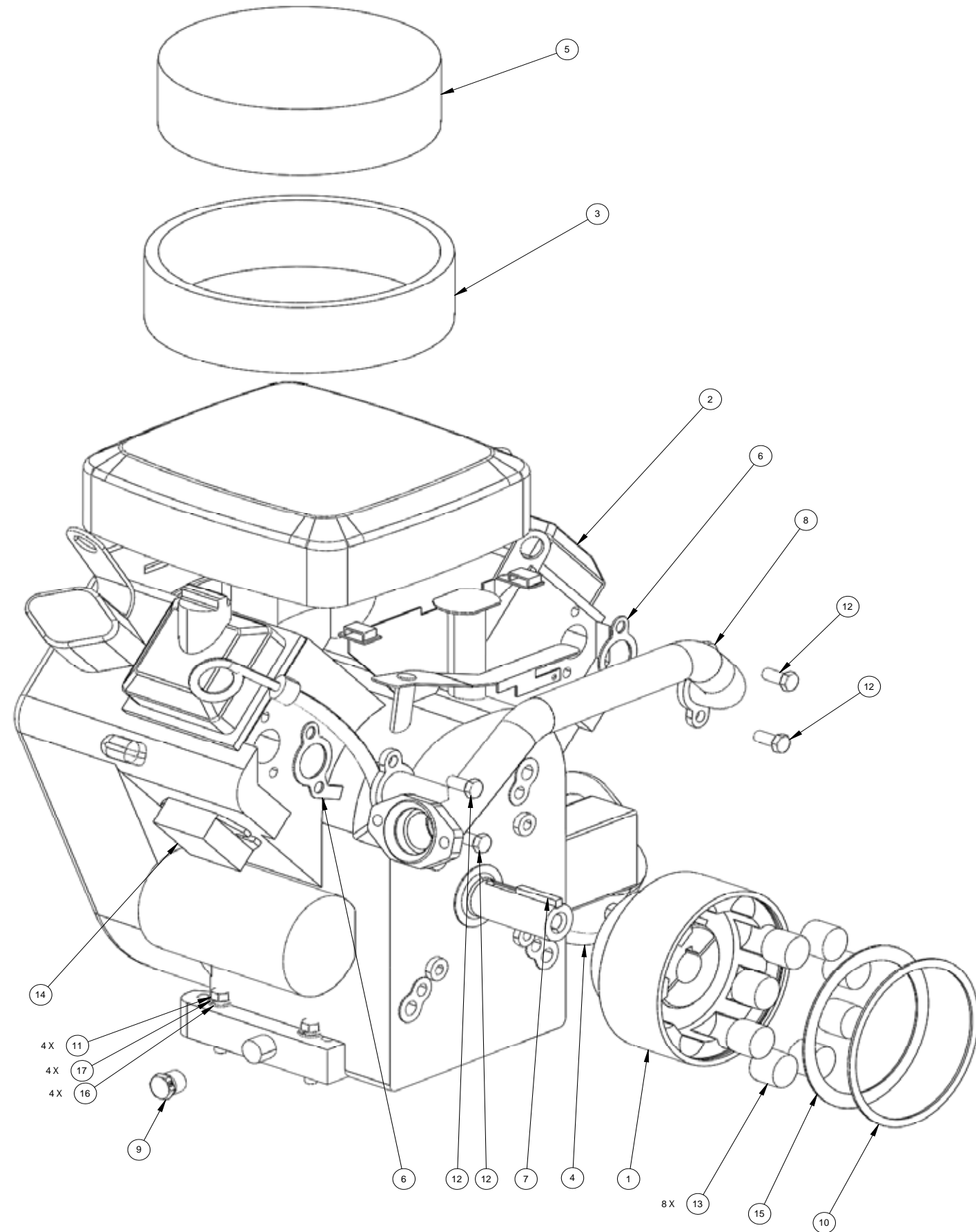
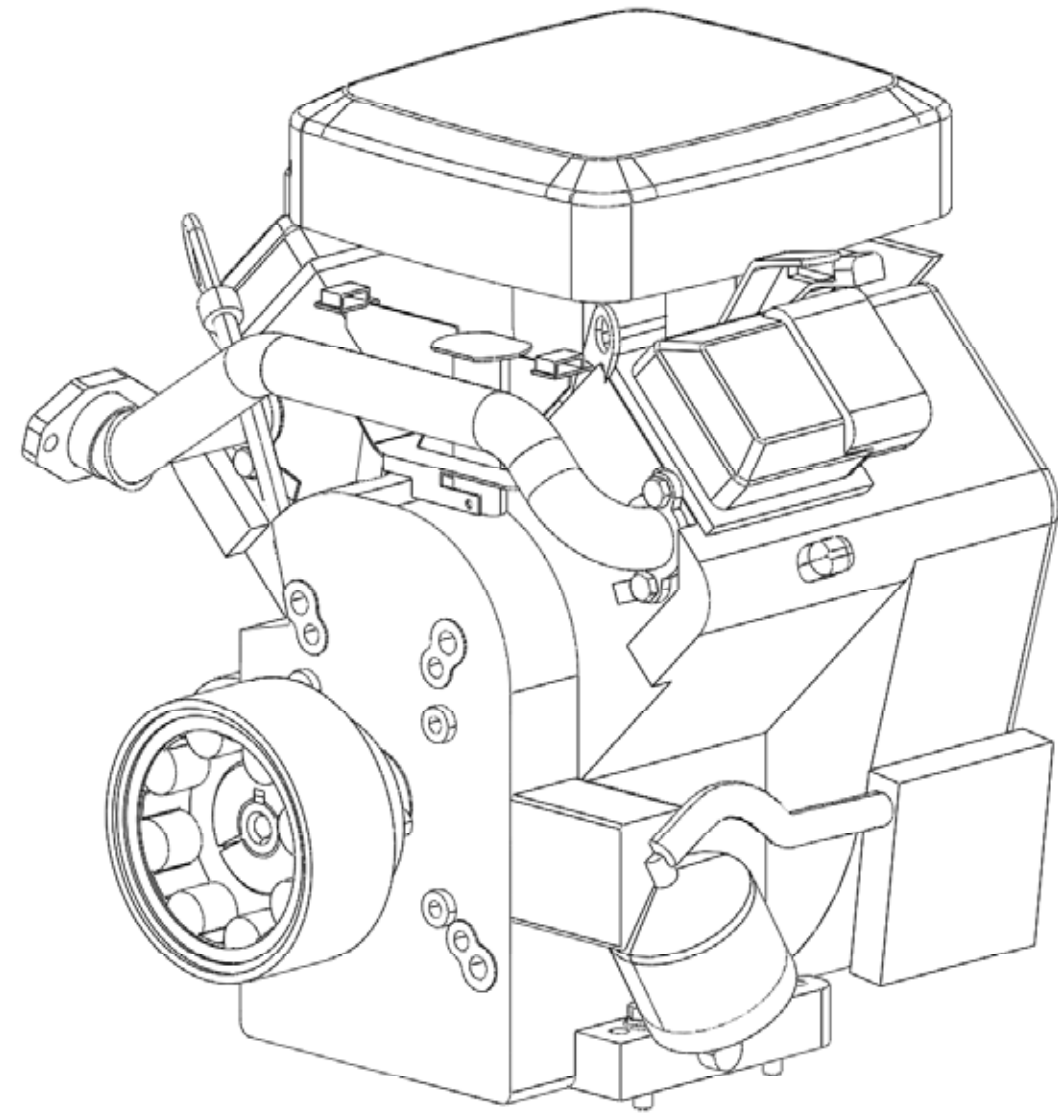


### Frame Assembly Parts List

Item	Part Number	Description	Qty	Item	Part Number	Description	Qty
1	000-001-098	Adapter, Exhaust Turndown - Welded	1	28	000-052-075	Nipple, 3/8" NPT X 1/2" NPT	1
2	610-009-720	Assembly, By-Pass Valve	1	29	000-094-034	Nut, #10-24UNC Nylock	4
3	610-026-004	Assembly, Chemical Check Valve	1	30	000-094-009	Nut, 1/4"-20UNC Nylock	4
4	610-008-720	Assembly, Hi-PSI Manifold	1	31	000-094-081	Nut, 5/16"-18UNC Hex 2 Way Locking	1
5	000-015-745	Bracket, After Burner Mounting Saddle - Fabricated	1	32	000-094-012	Nut, 5/16-18"UNC Hex	4
6	000-015-753	Bracket, Exhaust Support - Fabricated	1	33	000-106-122	Plug, Frame End - 2" Round	4
7	000-015-757	Bracket, Muffler Mounting - Coated	1	34	000-108-115	Protector, 5/8" Bumper	8
8	000-033-057	Clamp, 1" Cushion Loop	8	35	000-052-052	Quick Connect, 660 3/8" Brass w/ EPDM O-Ring	1
9	000-033-053	Clamp, 1-1/2" Cushion Loop	4	36	000-141-033	Rod, Heat Exchanger Strap Retainer - Fabricated	2
10	000-033-116	Clamp, 1-1/2" Cushion Loop w/ 7/16" Mounting Hole	1	37	000-143-126	Screw, #10-24UNC X 0.50" Lg. Hex Head	13
11	000-033-050	Clamp, 1-3/4" Cushion Loop	1	38	000-143-132	Screw, #10-24UNC X 0.75" Lg. Hex Head	3
12	000-033-046	Clamp, 1/2 Wide X 1/2 Tube	3	39	000-143-542	Screw, 1/4"-28UNF X 0.50" Lg. Hex Head	2
13	000-033-067	Clamp, 2" Cushion Loop	2	40	000-143-017-1	Screw, 3/8"-16UNC X 3/4" Lg. Hex Head	2
14	000-033-023	Clamp, 3/4" Nylon Hose	1	41	000-143-094-1	Screw, 3/8"-16UNC X 3/4" Lg. Socket Head	2
15	000-033-123	Clamp, After Burner Mount - 21.125" Lg.	1	42	000-143-143	Screw, 5/16"-18UNC X 1.00" Lg. Hex Head	2
16	000-052-083	Elbow, 3/8" NPT Street X 45°	1	43	000-143-316	Screw, 5/16-18 X 2" HHCS	1
17	000-055-149	Frame - Coated	1	44	000-154-125	Spacer, Removable Crossbar - Coated	1
18	000-056-006	Fuse Holder, In-Line - Weatherproof	1	45	000-157-012	Switch, Starter Solenoid 14HP	1
19	000-056-011	Fuse, 30 Amp	1	46	000-169-064	Valve, 3/8" NPT Full Port Ball	1
20	000-057-055	Gasket, Garden Hose	1	47	000-174-001	Washer, #10 Flat	14
21	000-060-010	Grommet, 1-5/16" I.D.	1	48	000-174-014	Washer, #10 Lock	2
22	000-060-013	Grommet, 3/4" I.D. Rubber	1	49	000-174-003	Washer, 1/4" Flat	4
23	000-060-002	Grommet, Large Wiring	1	50	000-174-049	Washer, 5/16" Flat	10
24	000-052-104	Insert, #66 (3/8" NPT X 3/8" Barb)	1	51	000-174-018	Washer, 5/16" Lock	6
25	000-052-105	Insert, #68 (3/8" NPT X 1/2" Barb)	1	52	000-174-008	Washer, 5/8" Flat	3
26	000-052-107	Insert, #88 (1/2" NPT X 1/2" Barb)	1	53	000-174-030	Washer, 5/8" I.D. X 7/8" O.D. X 0.010" Thk	1
27	000-163-056	Magnaclean, Hard Water Protector - Complete	1				



**Figure 9-9. Engine Assembly**  
610-004-720 Rev. C

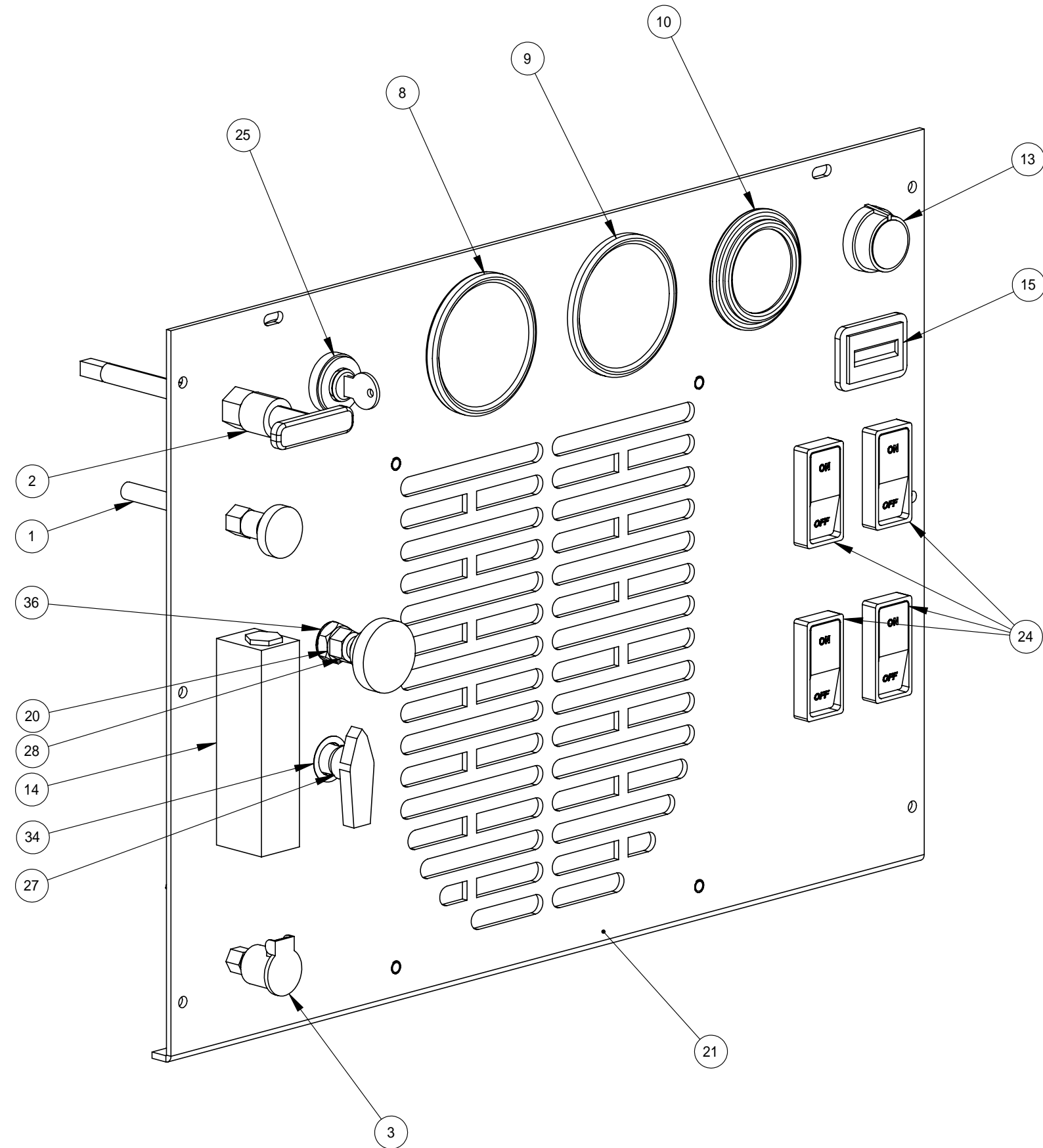


**Engine Assembly Parts List**

Item	Part Number	Description	Qty
1	000-039-030	Coupler, Balanced w/ 1" Bushing - Coated	1
2	000-047-012	Engine, 21HP	1
3	000-049-053	Filter, Foam Air Filter Element (Comes w/ Engine)	1
4	000-049-014	Filter, Oil (Comes w/ Engine)	1
5	000-049-012	Filter, 16HP Air-Vanguard I/C	1
6	000-057-082	Gasket, Exhaust Manifold - 21HP	2
7	000-077-006	Key, 0.25" X 1.5" Lg.	1
8	000-090-053	Manifold, Engine Exhaust - Coated	1
9	000-106-003	Plug, 3/8" NPT	1

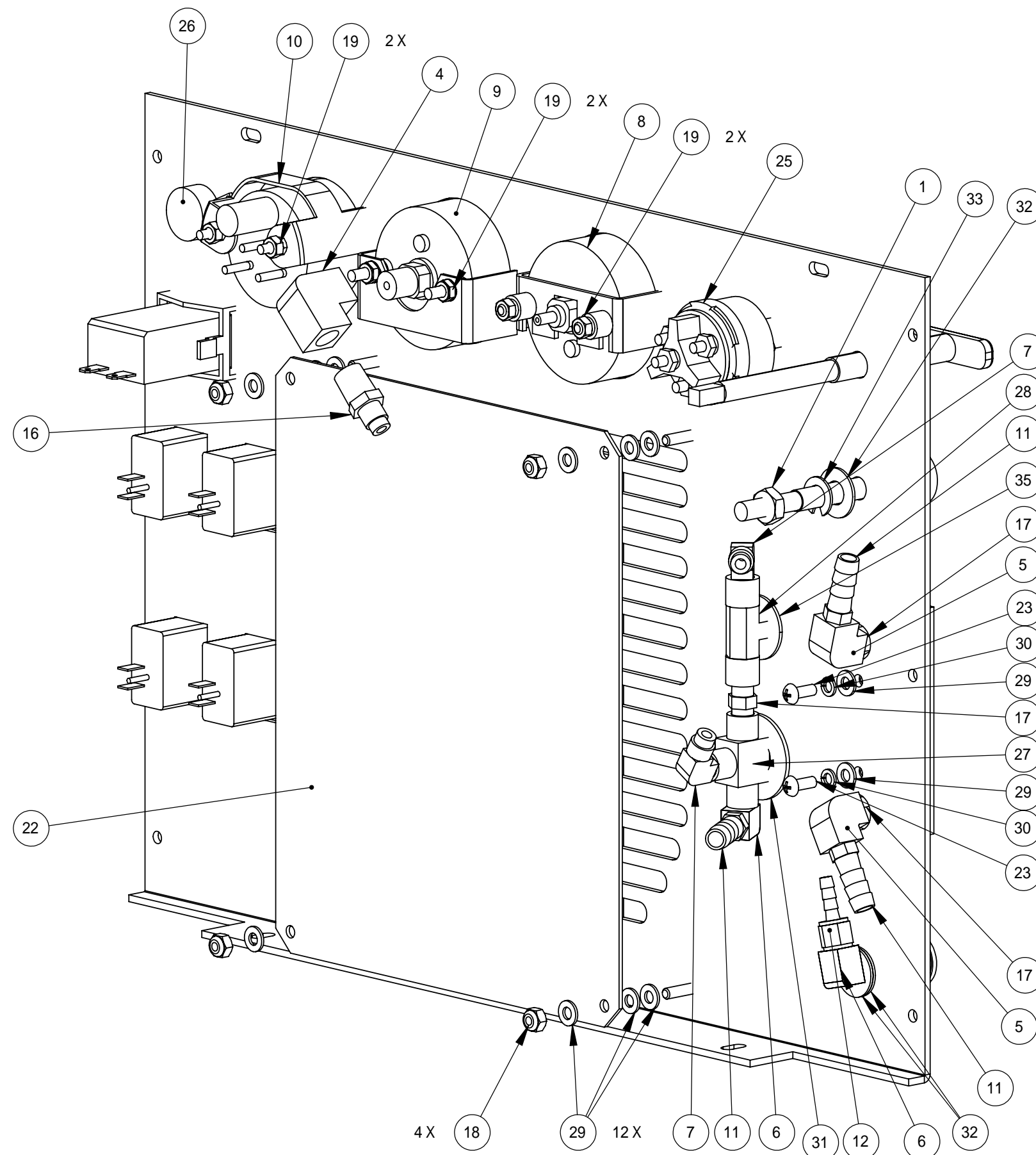
Item	Part Number	Description	Qty
10	000-139-022	Ring, 5" Retaining	1
11	000-143-375	Screw, 5/16"-18UNC X 1.75" Lg. Hex Head Grd. 8 Z/P	4
12	000-143-185	Screw, 8mm X 20mm Gr. 8.8 Hex Head	4
13	000-106-045	Plug, Coupler 1" O.D. X 0.875" Lg.	8
14	000-135-023	Voltage Regulator	1
15	000-174-080	Washer, 5.0" Drive Coupling	1
16	000-174-004	Washer, 5/16" Flat	4
17	000-174-018	Washer, 5/16" Lock	4

**Figure 9-10. Dash Assembly - View 1 of 2**  
610-018-720 Rev. J





**Figure 9-11. Dash Assembly View 2 of 2**  
610-018-720 Rev. J



### Dash Assembly Parts List

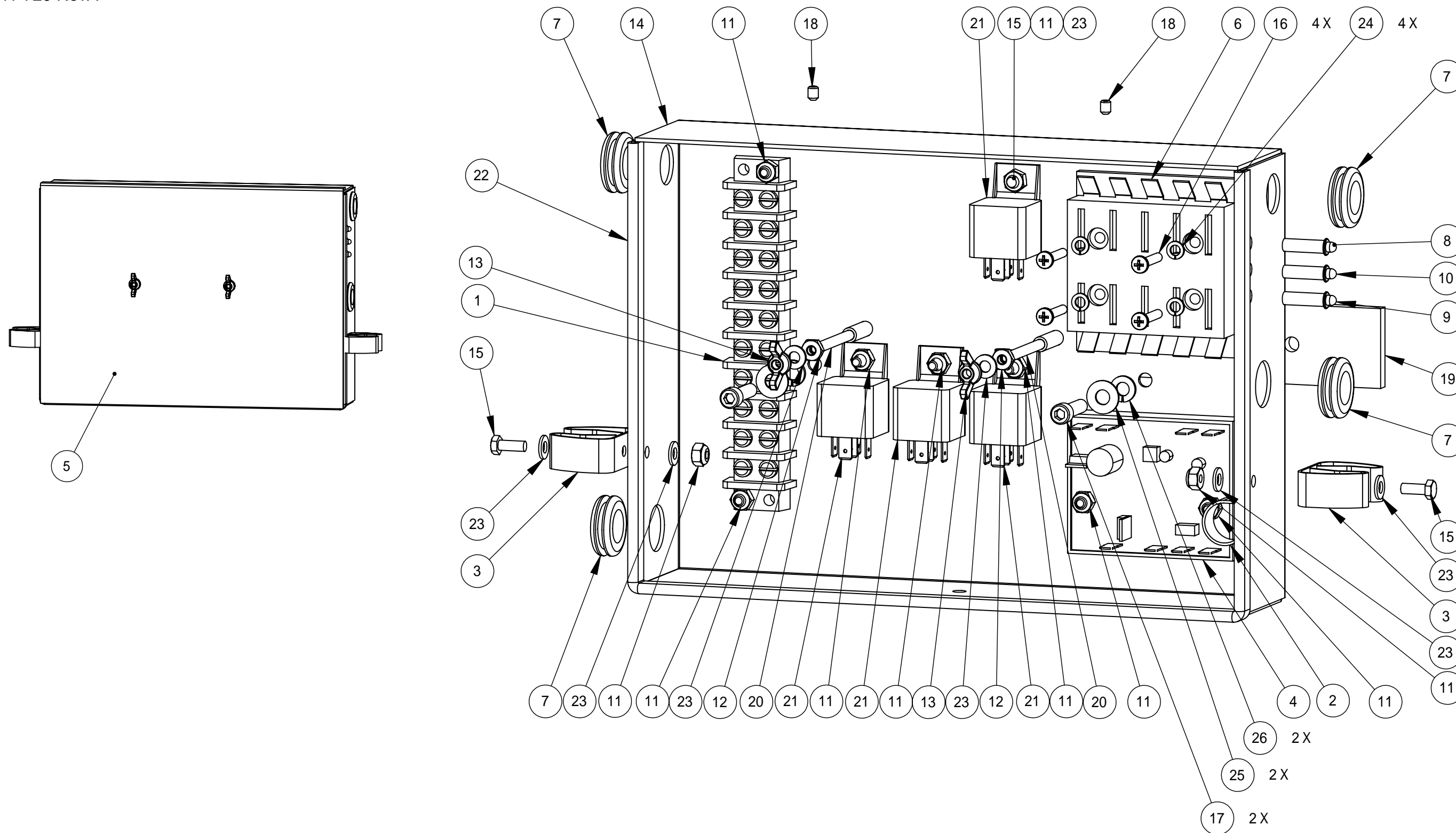
Item	Part Number	Description	Qty
1	000-025-011	Cable, Choke (5 ft)	1
2	000-025-030	Cable, Throttle	1
3	000-052-272	Cup, Gravity Feed Oil Blower Lube Port	1
4	000-052-088	Elbow, 1/4" FPT X FPT	1
5	000-052-089	Elbow, 1/8" NPT Female	2
6	000-052-084	Elbow, 1/8" NPT Street	2
7	000-052-531	Elbow, 1/8" NPT X 1/4" SAE	2
8	000-074-017	Gauge, 0-30" Hg Vac. 2 1/2"	1
9	000-074-007	Gauge, Pressure 0 -1,500 psi, UPC #401406.	1
10	000-074-016	Gauge, Temperature	1
11	000-052-099	Insert, #26 (1/8" NPT X 3/8" Barb)	3
12	000-052-096	Insert, #F23 (1/8" FPT X 3/16" Barb)	1
13	000-074-030	Meter, Chemical Flow Raw	1
14	000-074-170	Meter, Rectangular Hour w/o Bezel	1
15	000-052-527	Nipple, 1/4" SAE X 1/4" NPT	1
16	000-052-069	Nipple, 1/8" NPT Hex	3
17	000-094-034	Nut, #10-24UNC Nylock	4
18	000-094-070	Nut, 5mm Nylock	6

Item	Part Number	Description	Qty
19	000-094-098	Nut, 7/16"-24UNF - 2 Way Metering Valve	1
20	000-100-120	Panel, Dash - Coated	1
21	000-100-123	Panel, Perforated Grill - Coated	1
22	000-143-328	Screw, #10-32UNF X 1/2" Lg. Phillips Head	2
23	000-157-040	Switch, 20 Amp Rocker	4
24	000-157-008	Switch, Ignition	1
25	000-149-560	Thermostat, Potentiometer *	1
26	000-169-0171	Valve, 3-Way Ball O-Ring Style	1
27	000-169-160	Valve, Chemical Metering	1
28	000-174-001	Washer, #10 Flat	14
29	000-174-014	Washer, #10 Lock	2
30	000-174-034	Washer, 0.688" I.D. X 1.50" O.D. X 0.078" Thk.	1
31	000-174-032	Washer, 3/8" Flat	3
32	000-174-057	Washer, 3/8" Lock	1
33	000-174-030	Washer, 5/8" I.D. X 7/8" O.D. X 0.010" Thk	1
34	000-174-038	Washer, 7/16" SAE Flat	1
35	000-174-062	Washer, 1/2" I.D. X 3/4" O.D. X 0.010" Thk	1

#### NOTICE

\* To order a spare thermostat (P/N 000-149-560), specify P/N 000-149-561.

**Figure 9-12. Electrical Control Panel Assembly**  
610-011-720 Rev. F

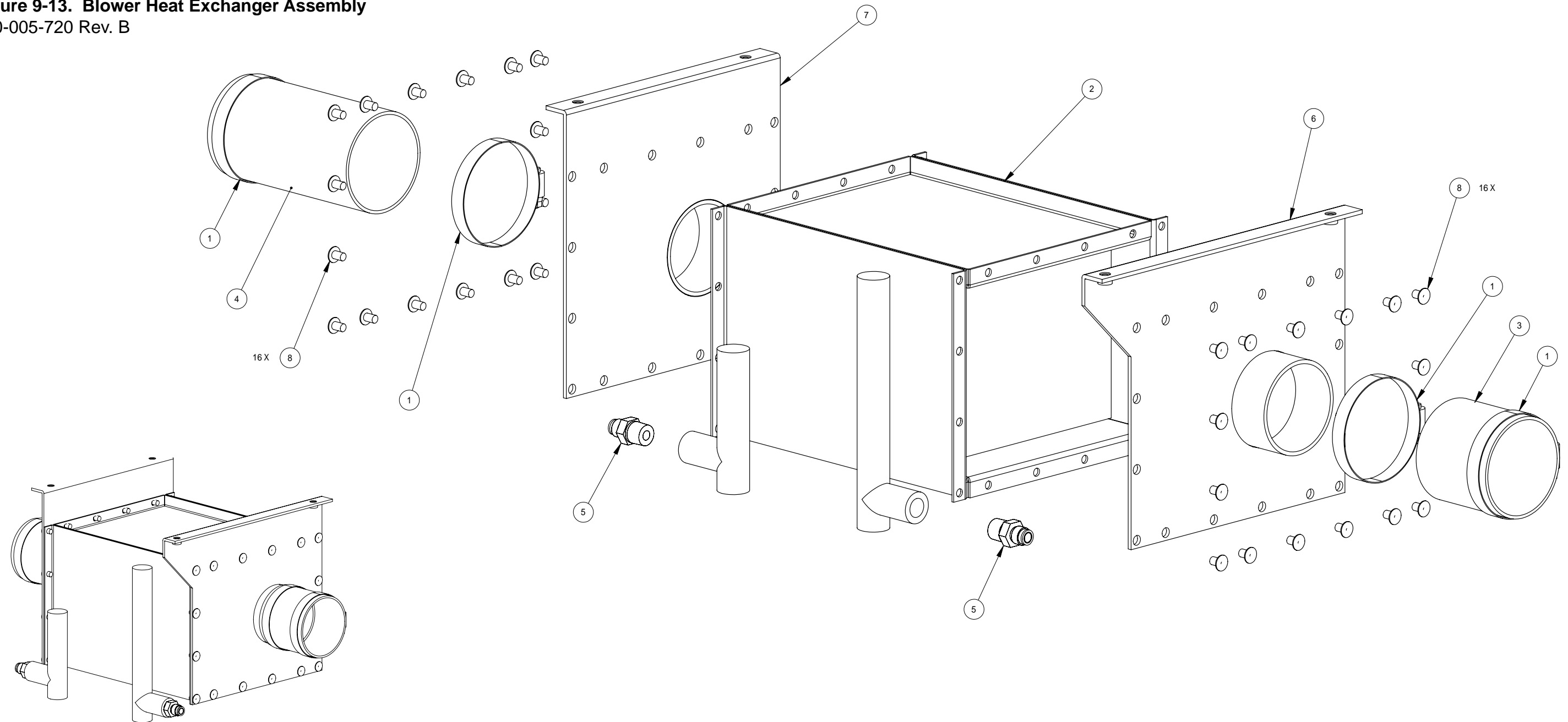


**Electrical Control Panel Assembly Parts List**

Item	Part Number	Description	Qty
1	000-012-010	Block, Terminal 10 Post	1
2	000-033-023	Clamp, 3/4" Nylon Hose	1
3	000-033-066	Clamp, 3/4" Spring	2
4	000-074-125	Controller, Temp Single Analog Input - RTD	1
5	000-041-377	Cover, Electrical Control Panel - Coated	1
6	000-056-020	Panel, Fuse	1
7	000-060-002	Grommet, Large Wiring	4
8	000-084-010	Light, Green LED Indicator Mini	1
9	000-084-011	Light, Red LED Indicator Mini	1
10	000-084-012	Light, Yellow LED Indicator Mini	1
11	000-094-034	Nut, #10-24UNC Nylock	12
12	000-094-058	Nut, #10-32UNF Nylock	2
13	000-094-108	Nut, #10-32UNF Wing	2

Item	Part Number	Description	Qty
14	000-100-121	Panel, Electrical Control - Coated	1
15	000-143-126	Screw, #10-24UNC X 0.50" Lg. Hex Head	3
16	000-143-545	Screw, #8-32UNC X 1" Lg. Pph	4
17	000-143-080	Screw, 1/4"-20UNC X 1.00" Lg. Socket Head	2
18	000-143-111	Set Screw, #10-24UNC X 0.25" Lg.	2
19	000-154-111	Spacer, Electrical Panel - Coated	1
20	000-156-040	Stud S/S 10-32 X 2 1/4"	2
21	000-157-022	Switch, Relay	4
22	000-131-027	Trimlok, 3/8" Wrinkled	1
23	000-174-001	Washer, #10 Flat	7
24	000-174-014	Washer, #10 Lock	4
25	000-174-003	Washer, 1/4" Flat	2
26	000-174-019	Washer, 1/4" Lock	2

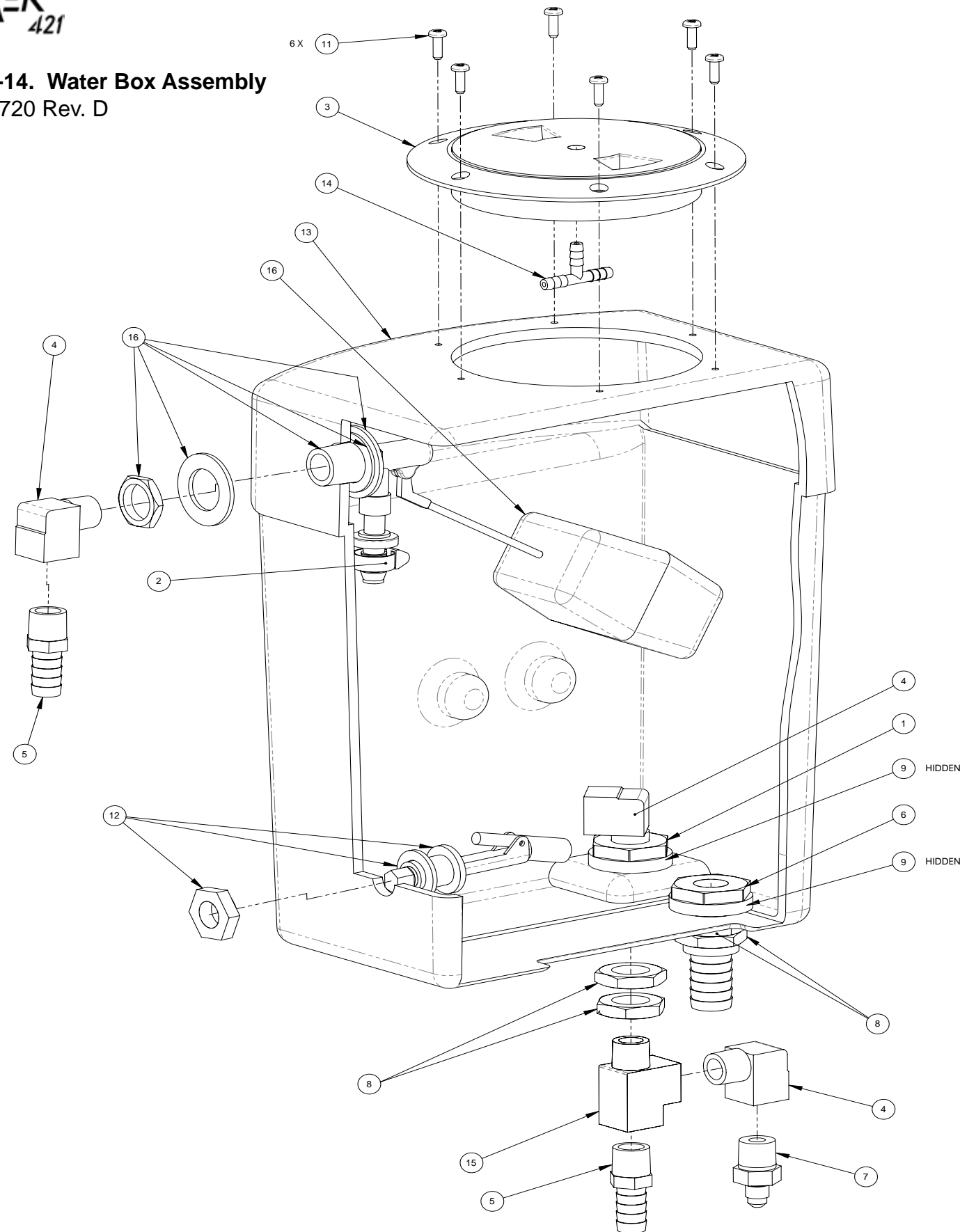
**Figure 9-13. Blower Heat Exchanger Assembly**  
610-005-720 Rev. B



**Blower Heat Exchanger Assembly Parts List**

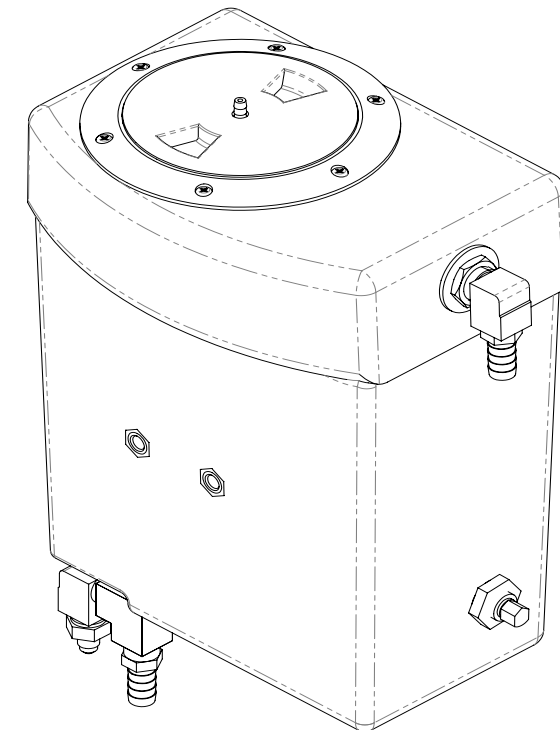
Item	Part Number	Description	Qty	Item	Part Number	Description	Qty
1	000-033-012	Clamp, Size #44 Hose	4	5	000-052-528	Nipple, 3/8" M JIC X 3/8" NPT	2
2	000-038-053	Core, Blower Heat Exchanger	1	6	000-100-117	Panel, End - Front - Blower Heat Exchanger - Weldment	1
3	000-068-946	Hose, 3" X 3" Lg. Blue Silicone	1	7	000-100-116	Panel, End - Rear - Blower Heat Exchanger - Weldment	1
4	000-068-947	Hose, 3" X 6" Lg. Blue Silicone	1	8	000-140-021	Rivet, 1/4" Blind X 0.50" Lg.	32

**Figure 9-14. Water Box Assembly**  
610-010-720 Rev. D



**Water Box Assembly Parts List**

Item	Part Number	Description	Qty
1	000-052-660	Bulkhead, 3/8" FPT X 3/8" FPT	1
2	000-033-005	Clamp, Size #5 Hose	1
3	000-041-365	Cover, 4" Round	1
4	000-052-086	Elbow, 3/8" NPT Street	3
5	000-052-105	Insert, #68 (3/8" NPT X 1/2" Barb)	2
6	000-052-661	Insert, 3/4" Barb X Straight	1
7	000-052-662	Nipple, 3/8" NPT X 1/4" M SAE	1
8	000-094-096	Nut, 3/4-16 Brass	4
9	000-097-041	O-Ring, 1/2" Bulk Head	2
10	000-143-314	Screw, #8 X 1/2" Lg. Pan Head	1
11	000-143-314	Screw, #8 X 1/2" Lg. Pan Head	5
12	"000-157-031	Switch, Side Mount w/ Bulkhead Fitting	1
13	000-159-153	Tank, Poly Water Box	1
14	000-052-155	Tee, 3/16" Plastic Vacuum Insert	1
15	000-052-023	Tee, 3/8" NPT Male Street	1
16	000-169-218	Valve, Float, Water Box	1

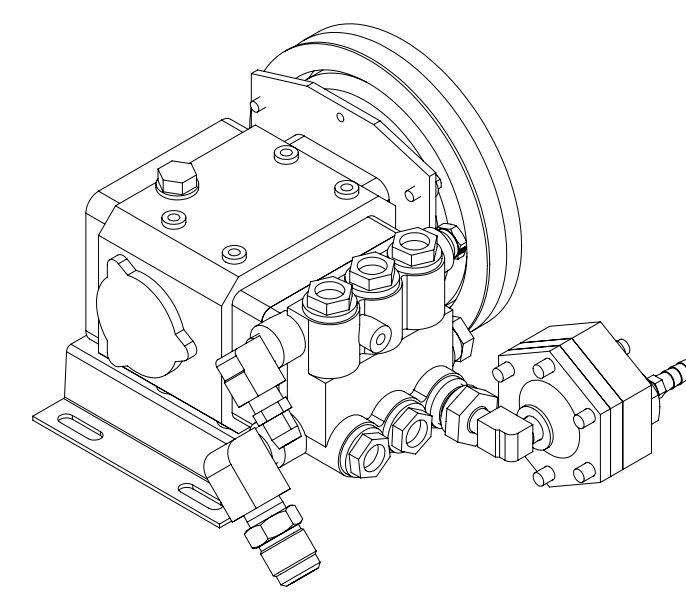
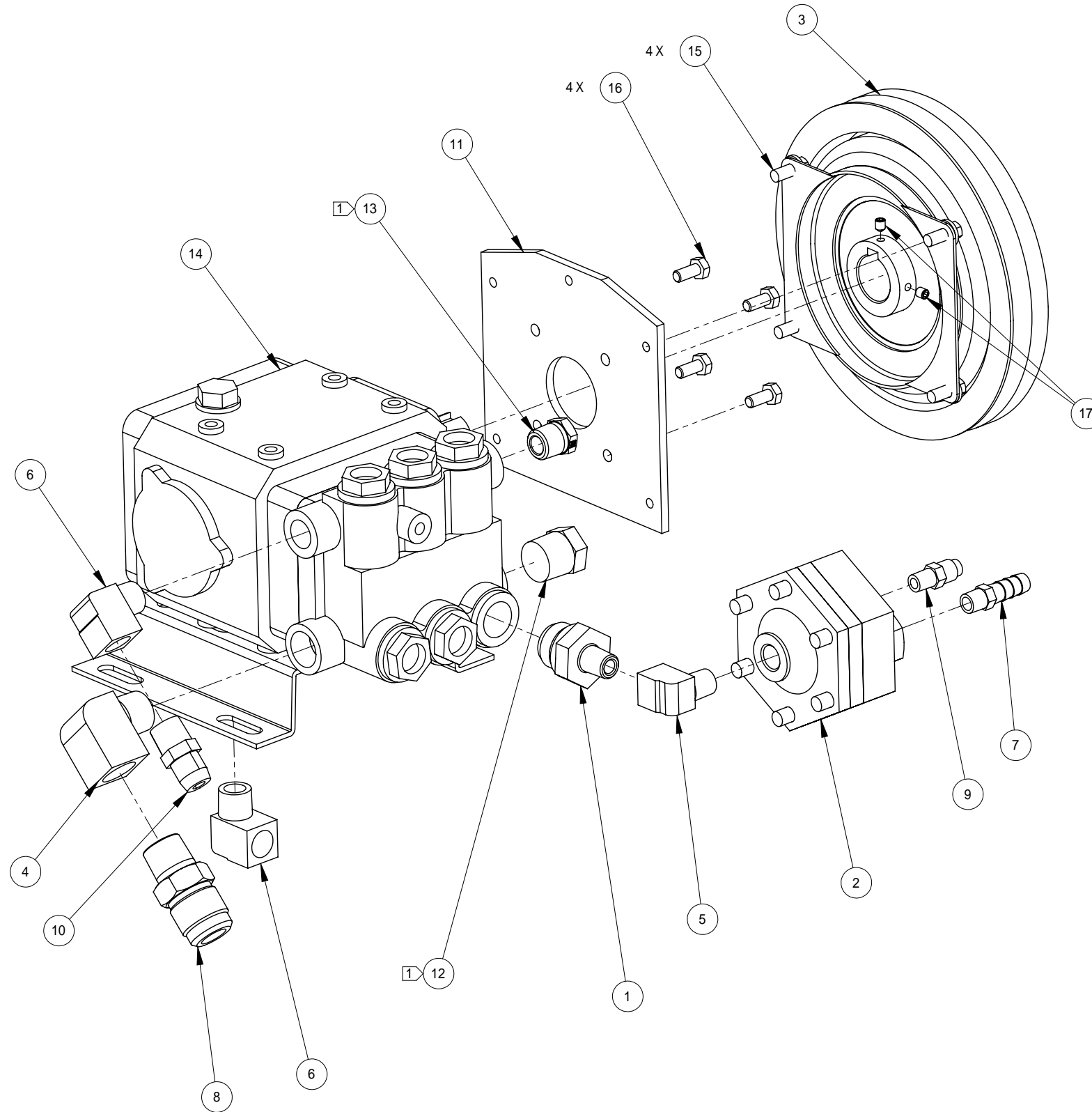




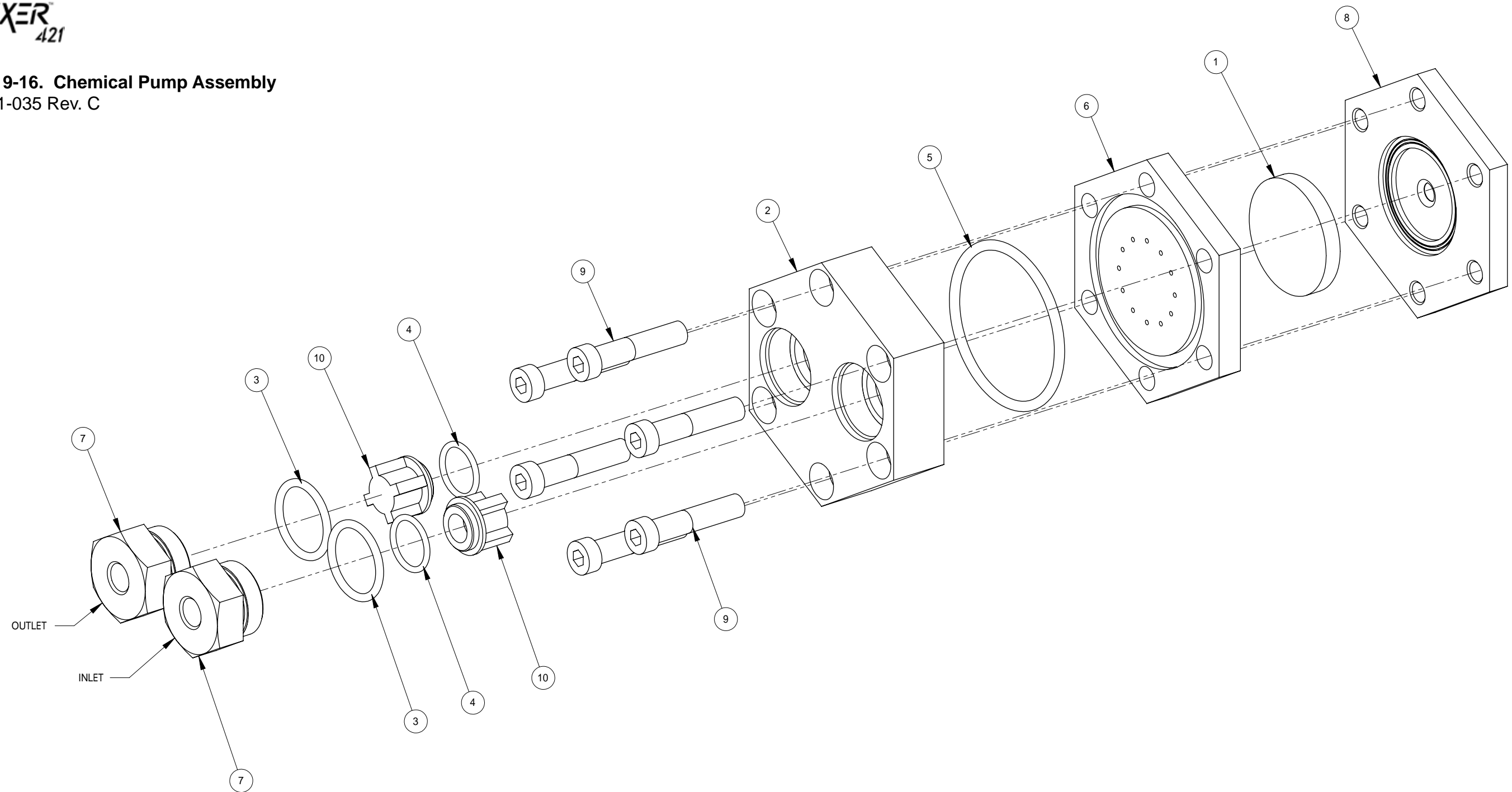
**Figure 9-15. Pump Assembly**  
610-007-720 Rev. C

**Pump Assembly Parts List**

Item	Part Number	Description	Qty
1	000-001-096	Adapter, Chemical Pump	1
2	000-111-035	Assembly, Chemical Pump	1
3	000-036-008	Clutch, 7" O.D. 24mm Single Groove	1
4	000-052-087	Elbow, 1/2" NPT Street	1
5	000-052-085	Elbow, 1/4" NPT Street	1
6	000-052-086	Elbow, 3/8" NPT Street	2
7	000-052-099	Insert, #26 (1/8" NPT X 3/8" Barb)	1
8	000-052-547	Nipple, 1/2 NPT X 3/4 SAE	1
9	000-052-530	Nipple, 1/4" SAE X 1/8" NPT	1
10	000-052-128	Nipple, 3/8 MPT X 3/8SAE Flare	1
11	000-105-148	Plate, Clutch Mount Pump	1
12	000-106-004	Plug, 1/2" NPT Hex	1
13	000-106-003	Plug, 3/8" NPT	1
14	000-111-042	Pump	1
15	000-143-141	Screw, 1/4"-20UNC X 1/2" Lg. Whiz Lock	4
16	000-143-221	Screw, M6-1 X 14mm Lg. Hex Head	4
17	000-143-580	Set Screw, 5mm X 0.8 X 6mm Lg. Cup Point	2



**Figure 9-16. Chemical Pump Assembly**  
000-111-035 Rev. C



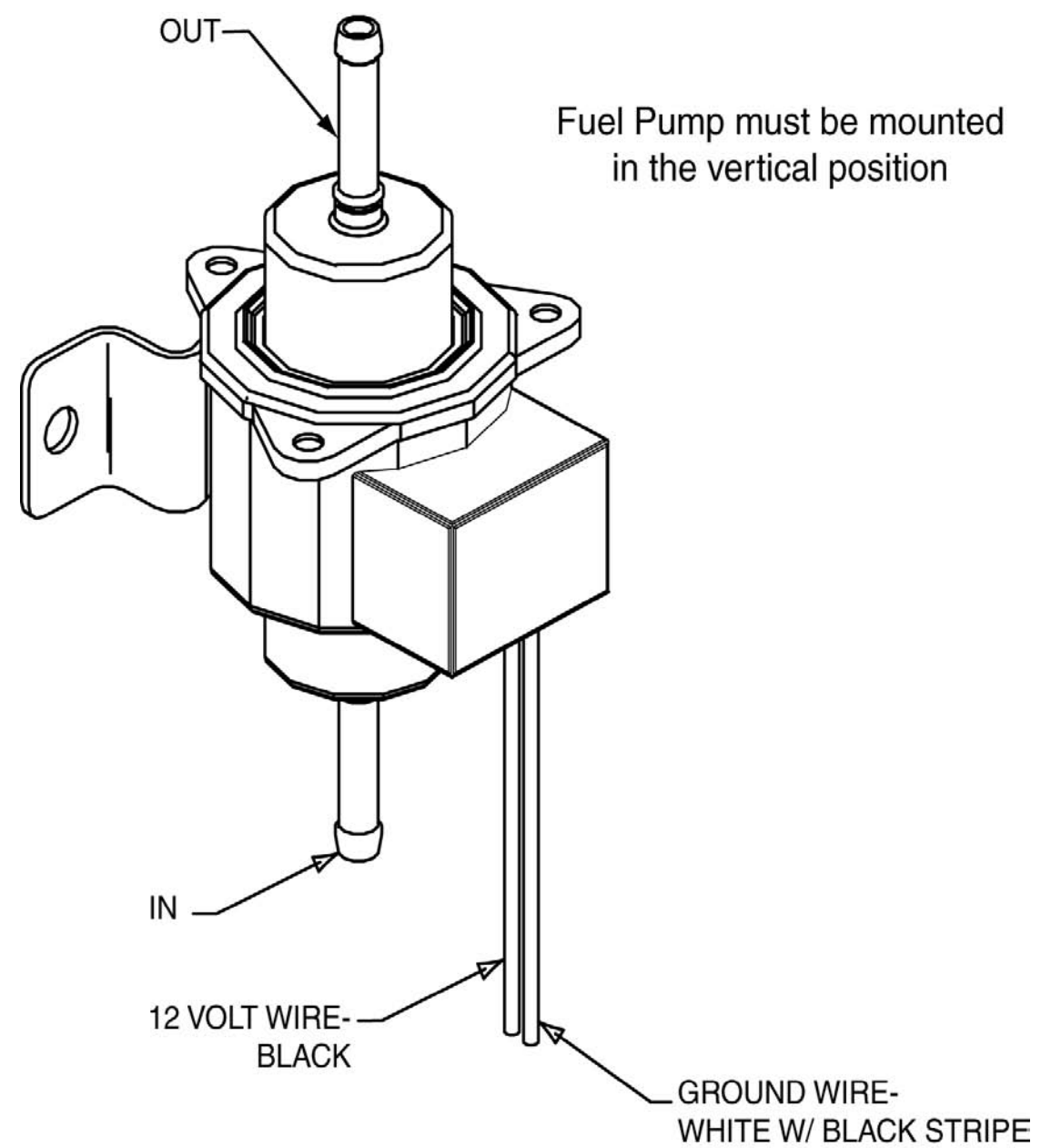
**Chemical Pump Assembly**

Item	Part Number	Description	Qty
1	000-046-010	Diaphragm, Chemical Pump	1
2	000-064-015	Head, Cover Chemical Pump	1
3	000-097-056	O-Ring, Check Valve Plug, An Size	2
4	000-097-054	O-Ring, Chemical Pump Valve	2
5	000-097-055	O-Ring, Chemical Pump Midplate An Size	1

Item	Part Number	Description	Qty
6	000-105-071	Plate, Mid - Chemical Pump	1
7	000-106-110	Plug, Check Valve - Chemical Pump	2
8	000-111-030	Pump, Body Chemical	1
9	000-143-152	Screw, 5/16"-24UNF X 1.50" Lg. Socket Head	6
10	000-169-155	Valve, Check - Last Step Chemical Injection	2



Figure 9-17. Fuel Pump Assembly  
4627

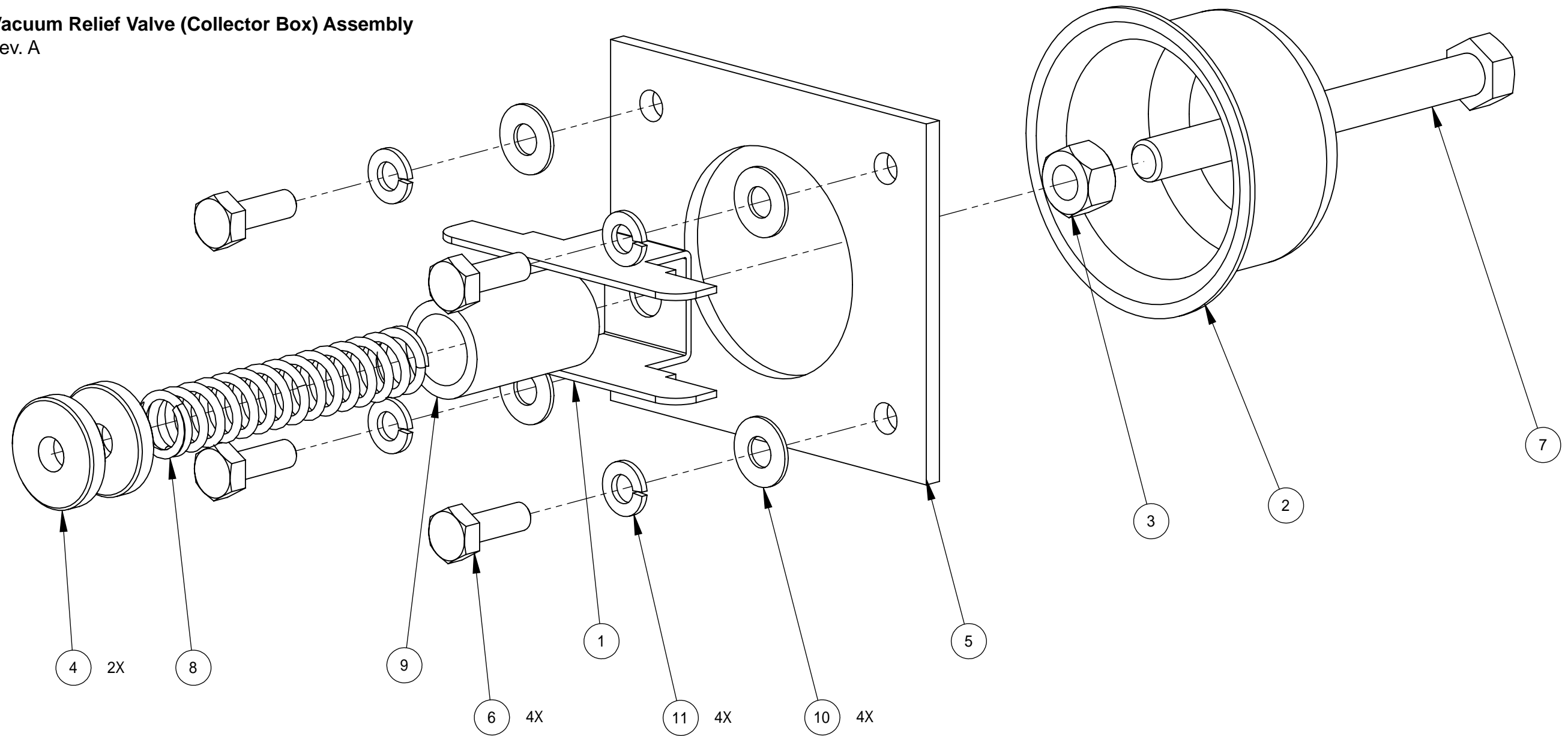




### Blower Assembly Parts List

Item	Part Number	Description	Qty	Item	Part Number	Description	Qty
1	000-001-024	Adapter, 2-1/2" NPT Blower To O-Ring Silencer	1	22	000-106-014	Plug, Vent	2
2	610-007-720	Assembly, Pump	1	23	000-108-120	Protector, Belt Guard - Coated	1
3	610-026-720	Assembly, Vacuum Relief Valve (Collector Box)	1	24	000-109-093	Pulley, 3" "A" Sect. Ball Bearing Assembly	1
4	610-010-720	Assembly, Water Box	1	25	000-109-040	Pulley, AK47-H	1
5	000-010-126	Belt, #25-9403 XI (40.625" Lg.)	1	26	000-143-048	Screw, #10-24UNC X 1/4" Lg. Pan Head Phillips	4
6	000-111-145	Blower, 4005 Dominator	1	27	000-143-041	Screw, 1/2-13UNC X 2-1/4" HHC	1
7	000-013-074	Box, Blower Collector - Coated	1	28	000-143-141	Screw, 1/4"-20UNC X 1/2" Lg. Whiz Lock	2
8	000-015-296	Bracket, Belt Guard Lower - Coated	1	29	000-143-001	Screw, 1/4"-20UNC X 3/4" Lg. Hex Head	2
9	000-015-814	Bracket, Dominator 4005 Mounting - Coated	2	30	000-143-018	Screw, 3/8"-16UNC X 1" Lg. Hex Head - Grade 8	6
10	000-015-746	Bracket, Pump Idler Mounting - Coated	1	31	000-143-263	Screw, 3/8"-16UNC X 3 3/4" HHCS	4
11	000-020-019	Bushing, #H X 7/8" Bore	1	32	000-143-017-1	Screw, 3/8"-16UNC X 3/4" Lg. Hex Head	6
12	000-039-040	Coupler, Balanced w/ Bushing and Inner Hub - Coated	1	33	000-143-028	Screw, 7/16"-14UNC X 1-3/4" HH Grd 5 Zinc	2
13	000-052-083	Elbow, 3/8" NPT Street X 45°	3	34	000-154-049	Spacer, Pump Idler Mounting - Coated	1
14	000-057-207	Gasket Vac Relief Valve Plate	1	35	000-169-070	Valve, Primary Vac. Solenoid	2
15	000-052-293	Insert, #23 (1/8" NPT X 3/16" Barb)	2	36	000-174-012	Washer, 1/2 SAE H/D	3
16	000-052-106	Insert, 1/8" NPT X 5/32" Barb X 90°	5	37	000-174-003	Washer, 1/4" Flat	2
17	000-077-001	Key, #3 and #4 Vacuum Pump Drive	2	38	000-174-032	Washer, 3/8" Flat	8
18	000-094-038	Nut, 5/16"-18UNC Nylock	4	39	000-174-057	Washer, 3/8" Lock	9
19	000-094-014	Nut, 3/8-16 Hex Z/P	2	40	000-174-029	Washer, 3/8" Rubber Backed	4
20	000-097-029	O-Ring, 2 1/2" I.D. X 2 3/4" O.D X 1/8	1	41	000-174-004	Washer, 5/16" Flat	4
21	000-105-207	Plate, Pump Idler - Coated	1	42	000-174-068	Washer, Blower Feet - Coated	2

**Figure 9-19. Vacuum Relief Valve (Collector Box) Assembly**  
610-026-720 Rev. A

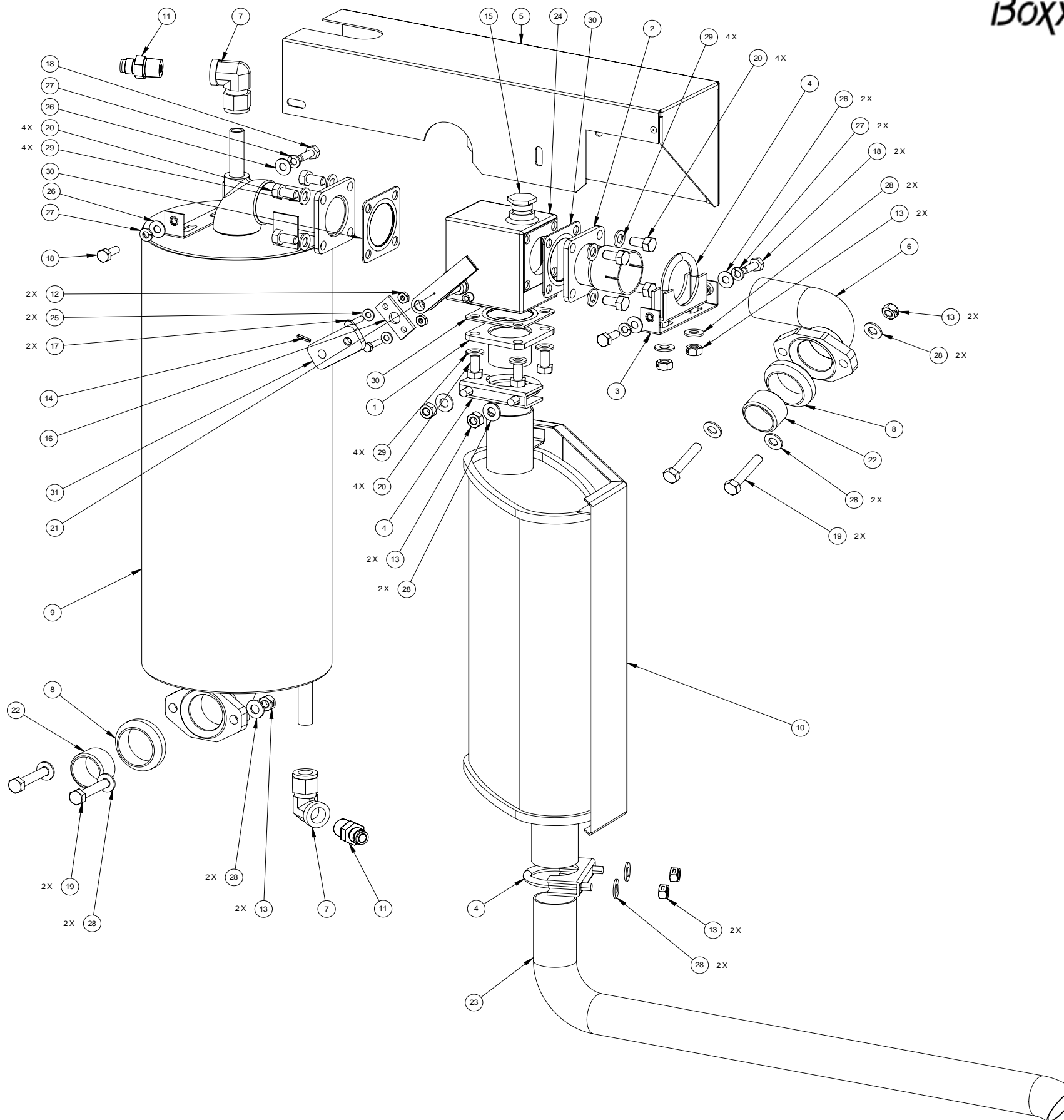
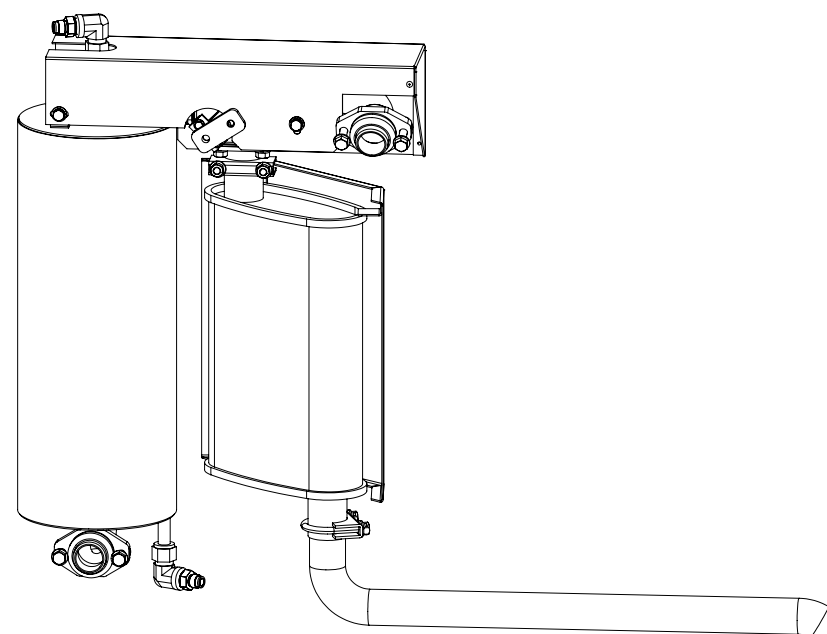


**Vacuum Relief Valve (Collector Box) Assembly Parts List**

Item	Part Number	Description	Qty
1	000-015-182	Bracket, Vacuum Relief Valve - Fabricated	1
2	000-027-032	Cap, Spun Vacuum Relief Valve	1
3	000-094-101	Nut, 3/8"-16UNC Hex Jam	1
4	000-094-077	Nut, 3/8"-16UNC X 1.00" O.D. Knurled	2
5	000-105-337	Plate, Vacuum Relief Valve Mounting - Coated	1
6	000-143-001	Screw, 1/4"-20UNC X 0.75" Lg. Hex Head	4

Item	Part Number	Description	Qty
7	000-143-198	Screw, 3/8"-16UNC X 4" Lg. Hex Head - Full Thread	1
8	000-155-026	Spring, Vacuum Relief Valve	1
9	000-125-111	Tube, Vacuum Relief Spring Guide	1
10	000-174-003	Washer, 1/4" Flat	4
11	000-174-019	Washer, 1/4" Lock	4

**Figure 9-20. Exhaust Assembly**  
610-013-720 Rev. E

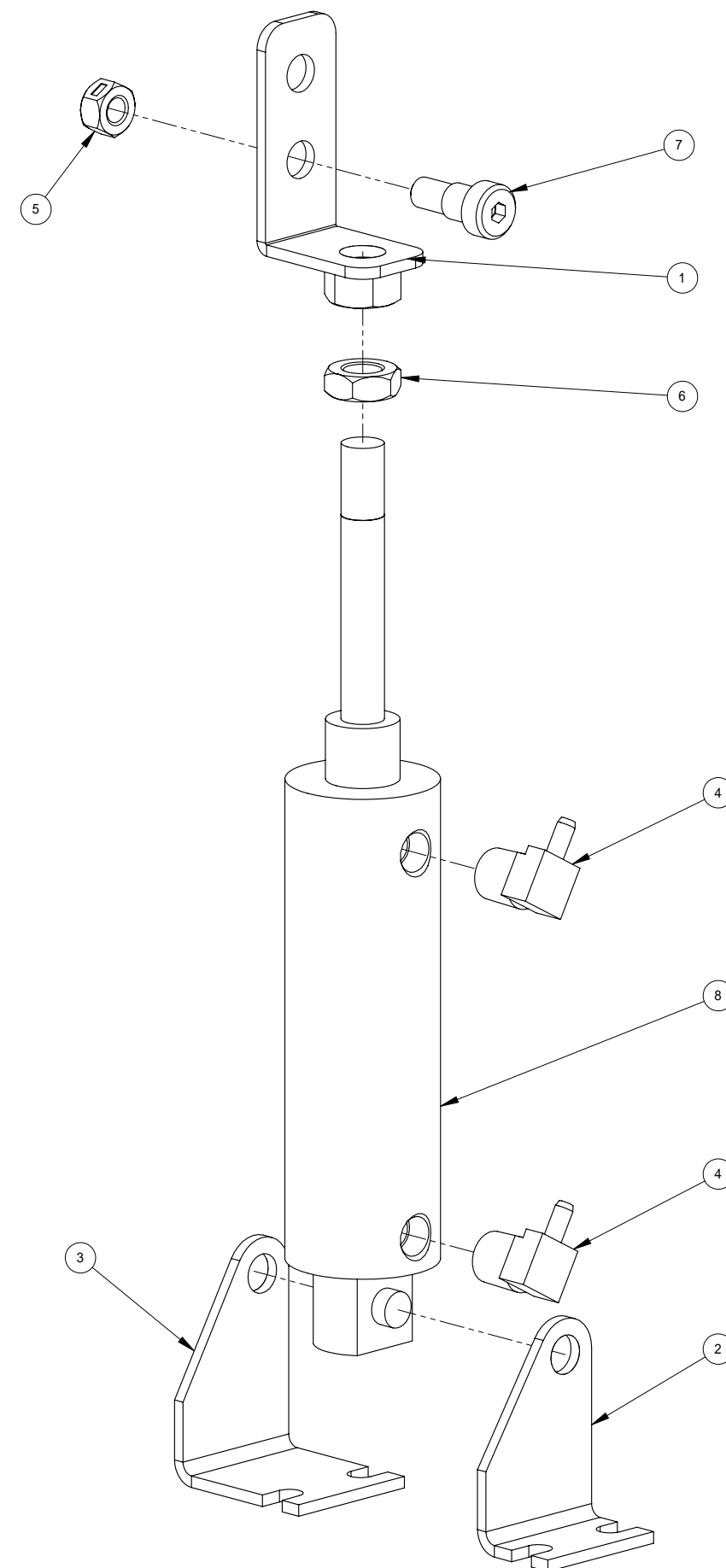
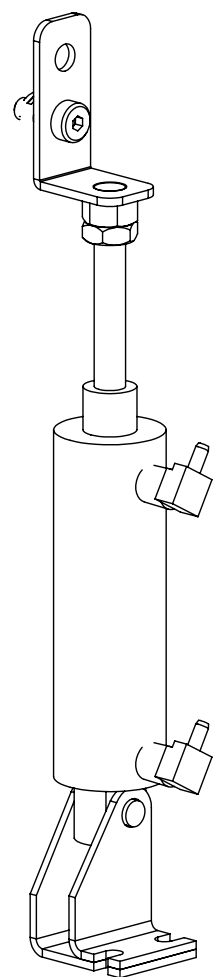




**Exhaust Assembly Parts List**

Item	Part Number	Description	Qty	Item	Part Number	Description	Qty
1	000-001-102	Adapter, Exhaust Flange To 1.50" M Slip"	1	17	000-143-132	Screw, #10-24UNC X 0.75" Lg. Hex Head	2
2	000-001-099	Adapter, Exhaust Flange To Ø1.50" F Slip	1	18	000-143-001	Screw, 1/4"-20UNC X 3/4" Lg. Hex Head	4
3	000-015-764	Bracket, Exhaust Cover Mounting - Fabricated	1	19	000-143-124	Screw, 5/16"-18UNC X 1.75" Lg. Hex Head	4
4	000-033-068	Clamp, 1-1/2" Exhaust	3	20	000-143-572	Screw, 5/16-18UNC X 5/8" Lg. Grd. 5 Hex Head	12
5	000-041-382	Cover, Exhaust - Fabricated	1	21	000-155-030	Spring, Leaf - Weldment	1
6	000-052-703	Elbow, Exhaust Manifold to Diverter	1	22	000-125-128	Tube, 1-3/8" O.D. X 1/8" Wall X 7/8" Long	2
7	000-052-600	Elbow, 1/2 Tube X 3/8 FPT	2	23	000-125-152	Tube, Muffler Outlet	1
8	000-057-177	Gasket, Exhaust Donut 1.50"	2	24	000-169-045	Valve, Cast Exhaust Diverter	1
9	000-038-054	Heat Exchanger, After Burner - Weldment	1	25	000-174-001	Washer, #10 Flat	2
10	000-093-081	Muffler, 1.50" Offset Inlet / OutLet w/ Heat Shield	1	26	000-174-003	Washer, 1/4" Flat	4
11	000-052-528	Nipple, 3/8" M JIC X 3/8" Npt	2	27	000-174-019	Washer, 1/4" Lock	4
12	000-094-027	Nut, #10-24UNC Hex	2	28	000-174-049	Washer, 5/16" Flat	14
13	000-094-081	Nut, 5/16"-18UNC Hex 2 Way Locking	10	29	000-174-069	Washer, 5/16" Inconel Belleville	12
14	000-103-005	Pin, Roll - 0.125" X 0.500" Lg.	1	30	000-057-146	Gasket, Four Hole Exhaust	3
15	000-106-120	Plug, M18 X 1.5	1	31	000-015-642	Bracket, Air Cylinder Actuation - Coated	1
16	000-138-010	Retainer, Leaf Spring	1				

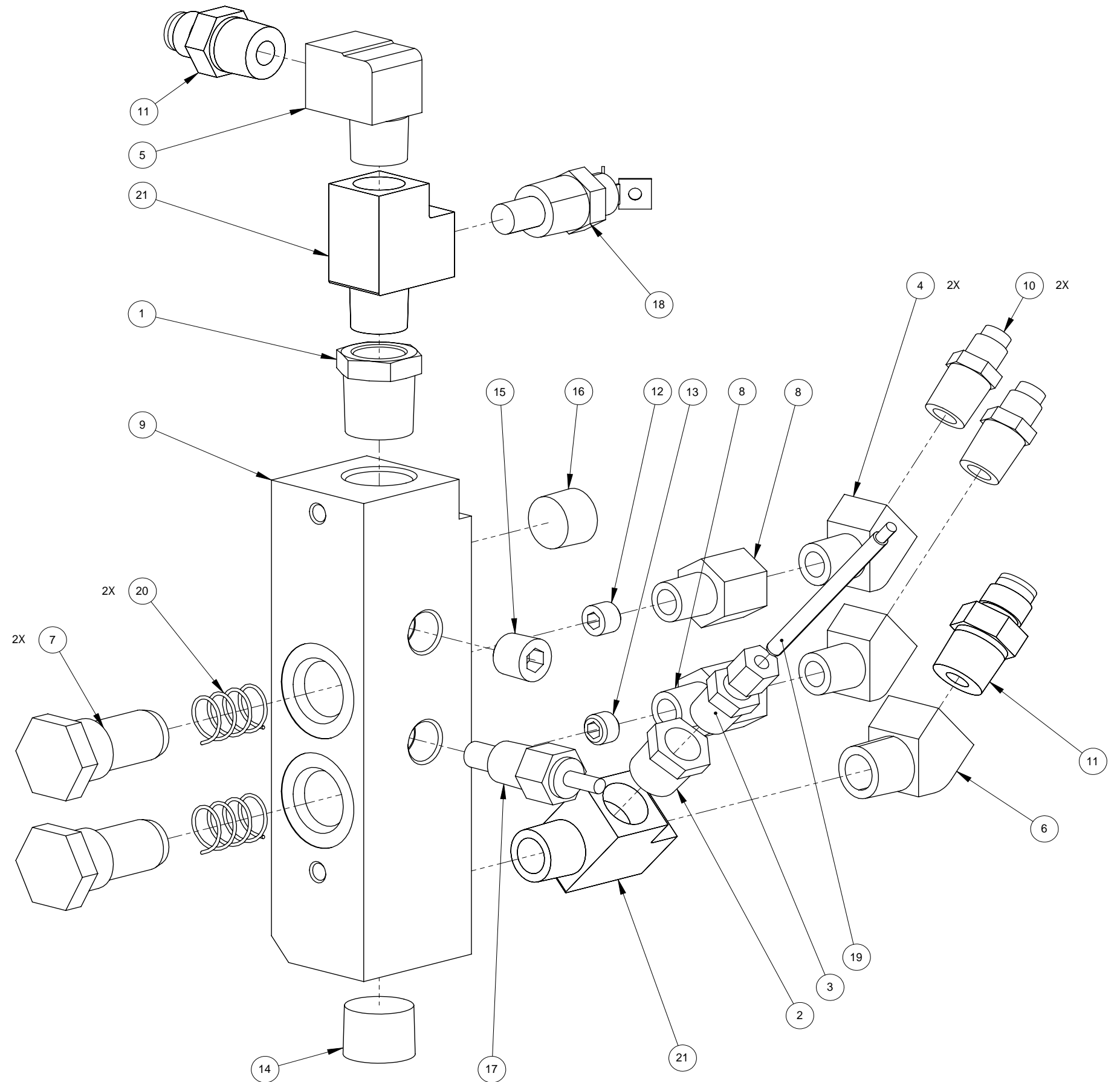
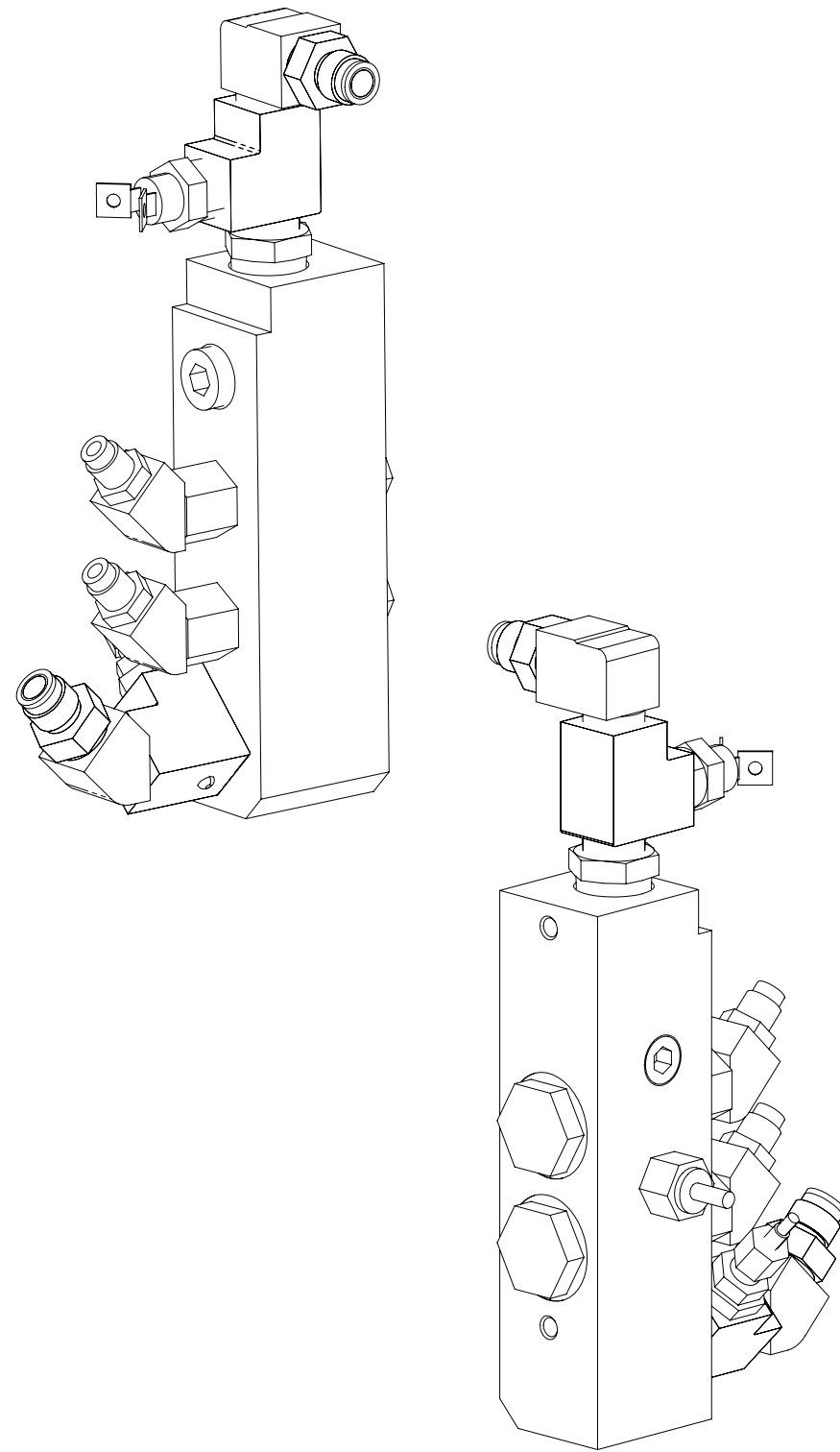
**Figure 9-21. Diverter Valve Actuator Assembly**  
610-014-720 Rev. C



**Diverter Valve Actuator Assembly Parts List**

Item	Part Number	Description	Qty
1	000-015-630	Bracket, Air Cylinder Extension - Coated	1
2	000-015-750	Bracket, Air Cylinder Mount - Inner- Coated	1
3	000-015-748	Bracket, Air Cylinder Mount - Outer - Coated	1
4	000-052-550	Elbow, 1/8" NPT X 3/16" Barb	2
5	000-094-081	Nut, 5/16"-18UNC Hex 2 Way Locking	1
6	000-094-092	Nut, 7/16"-20UNF Hex Jam	1
7	000-143-573	Screw, 5/16"-18UNC X 7/8" Lg.	1
8	000-169-169	Valve, Air Cylinder	1

**Figure 9-22. Hi PSI Manifold Assembly**  
610-008-720 Rev. C



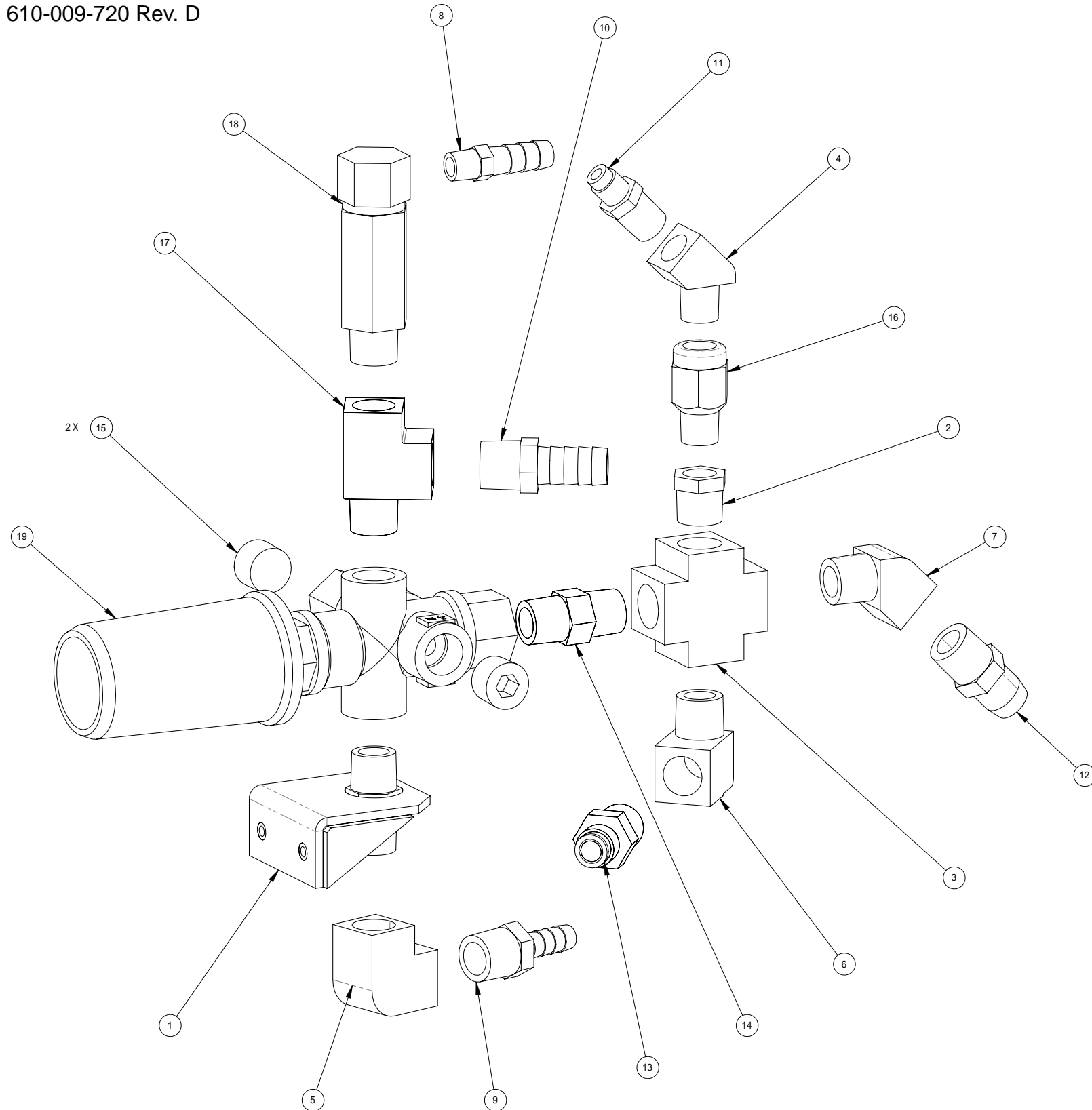


### Hi PSI Manifold Assembly Parts List

Item	Part Number	Description	Qty
1	000-052-064	Bushing, 1/2 M X 3/8 F	1
2	000-052-061	Bushing, 3/8" NPT X 1/4" FPT	1
3	000-052-587	Compression, 3/16" X 1/4" NPT Thermocouple	1
4	000-052-082	Elbow, 1/4" NPT Street X 45°	2
5	000-052-086	Elbow, 3/8" NPT Street	1
6	000-052-083	Elbow, 3/8" NPT Street X 45°	1
7	000-049-016	Filter, 1/4" NPT Replacement "Y"	2
8	000-052-423	Fitting, Bushing Modified Orifice Housing	2
9	000-090-010	Manifold, Hi-PSI	1
10	000-052-527	Nipple, 1/4" SAE X 1/4" NPT	2
11	000-052-528	Nipple, 3/8" M JIC X 3/8" NPT	2

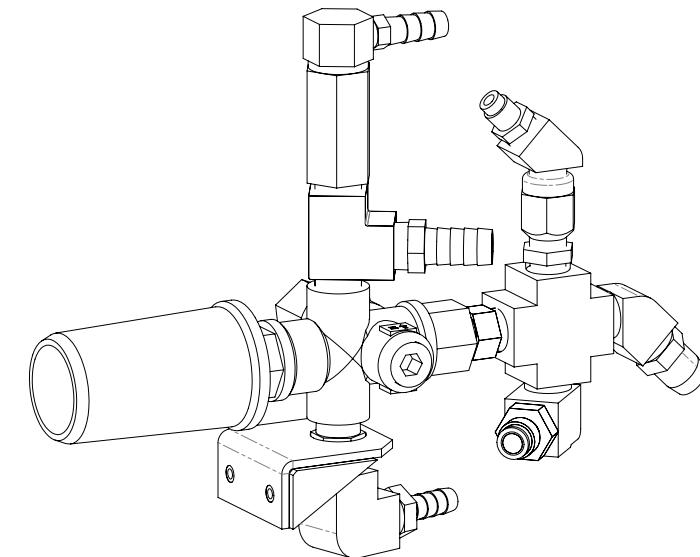
Item	Part Number	Description	Qty
12	000-180-004	Orifice, Set Screw - 0.033"	1
13	000-180-006	Orifice, Set Screw - 0.063"	1
14	000-106-111	Plug, 1/2" NPT Allen Head	1
15	000-106-007	Plug, 1/4" NPT Allen Head	1
16	000-106-008	Plug, 3/8" NPT Allen Head	1
17	000-149-039	Sender, Temperature	1
18	000-149-027	Sensor, 285F Nason- 3/8" NPT	1
19	000-149-540	Sensor, RTD Compression Fitting Style	1
20	000-155-020	Spring, 0.540 O.D. X 0.041 Wire X 1.00 Lg.	2
21	000-052-023	Tee, 3/8" NPT Male Street	2

**Figure 9-23. By-Pass Valve Assembly**  
610-009-720 Rev. D



**By-Pass Valve Assembly Parts List**

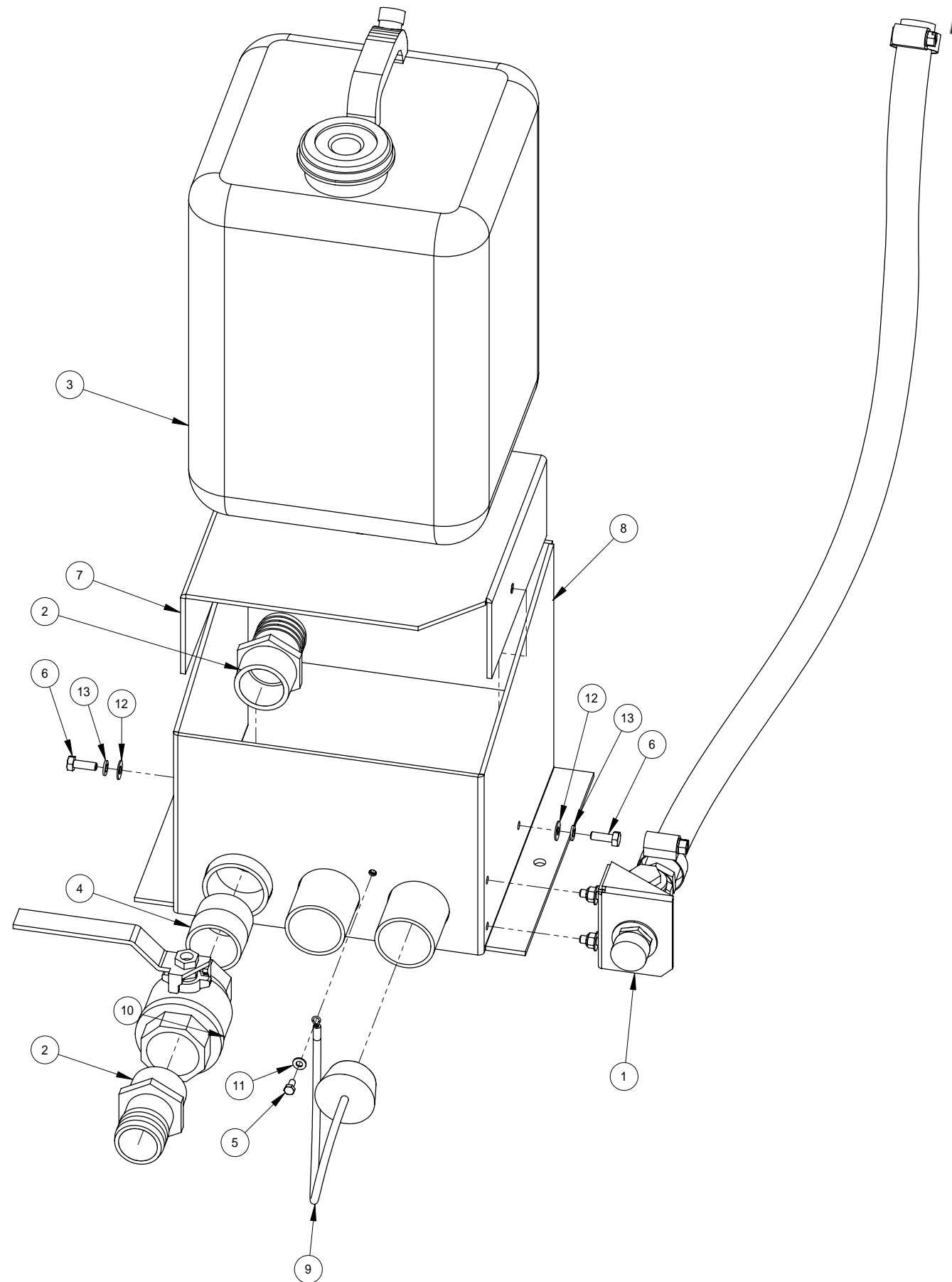
Item	Part Number	Description	Qty
1	000-015-515	Bracket, Cat By-Pass Valve Mount - Weldment	1
2	000-052-061	Bushing, 3/8" NPT X 1/4" FPT	1
3	000-052-113	Cross, 3/8" FPT	1
4	000-052-082	Elbow, 1/4" NPT Street X 45°	1
5	000-052-142	Elbow, 3/8" F X F Brass	1
6	000-052-086	Elbow, 3/8" NPT Street	1
7	000-052-083	Elbow, 3/8" NPT Street X 45°	1
8	000-052-099	Insert, #26 (1/8" NPT X 3/8" Barb)	1
9	000-052-104	Insert, #66 (3/8" NPT X 3/8" Barb)	1
10	000-052-105	Insert, #68 (3/8" NPT X 1/2" Barb)	1
11	000-052-527	Nipple, 1/4" SAE X 1/4" NPT	1
12	000-052-128	Nipple, 3/8 MPT X 3/8SAE Flare	1
13	000-052-528	Nipple, 3/8" M JIC X 3/8" NPT	1
14	000-052-074	Nipple, 3/8" NPT Hex	1
15	000-106-008	Plug, 3/8" NPT Allen Head	2
16	000-135-052	Regulator, Hi PSI Snubber	1
17	000-052-023	Tee, 3/8" NPT Male Street	1
18	000-169-188	Valve Pressure Regulator-Modified	1
19	000-169-011	Valve, Hi Temp Control 180°	1



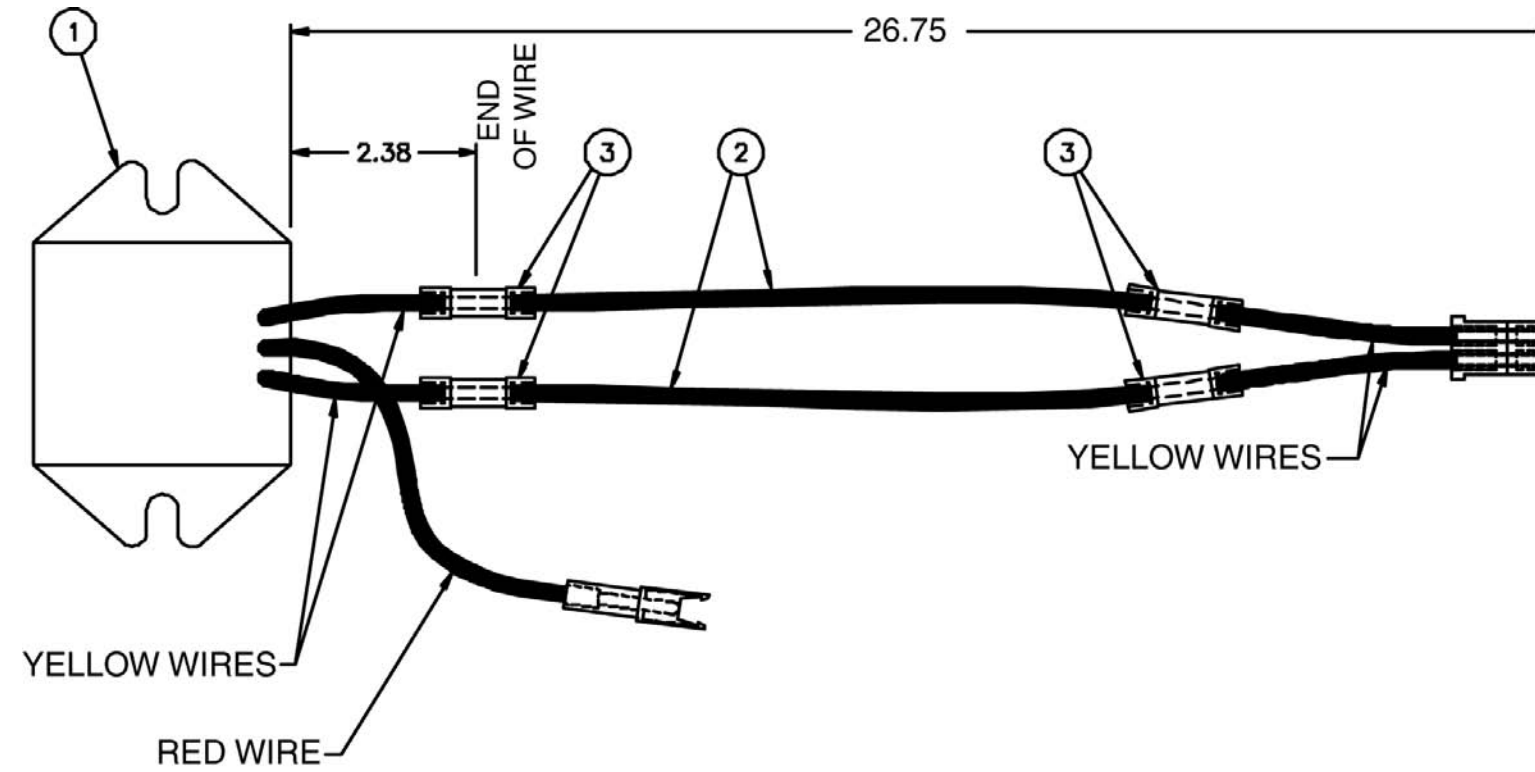
**Figure 9-24. Chemical Jug Tray Assembly**  
610-015-741 Rev. E

**Chemical Jug Tray Assembly Parts List**

Item	Part Number	Description	Qty
1	610-021-010	Assembly, APO Connection Kit	1
2	000-052-226	Insert, 1-1/2" NPT X 1-1/2" Barb (Gray)	2
3	000-159-016	Jug, 5 Gallon Plastic Chemical - Standard	1
4	000-052-182	Nipple, 1-1/2" NPT Close	1
5	000-143-166	Screw, #10-24UNC X 3/8" Lg. Hex Head	1
6	000-143-001	Screw, 1/4"-20UNC X 3/4" Lg. Hex Head	2
7	000-166-025	Tray, Chemical Jug - Inner - Coated	1
8	000-166-023	Tray, Outer Chemical Jug - Coated	1
9	000-078-039	Vacuum Inlet Stopper	1
10	000-169-022	Valve, 1-1/2" Full Port Ball	1
11	000-174-001	Washer, #10 Flat	1
12	000-174-003	Washer, 1/4" Flat	2
13	000-174-019	Washer, 1/4" Lock	2

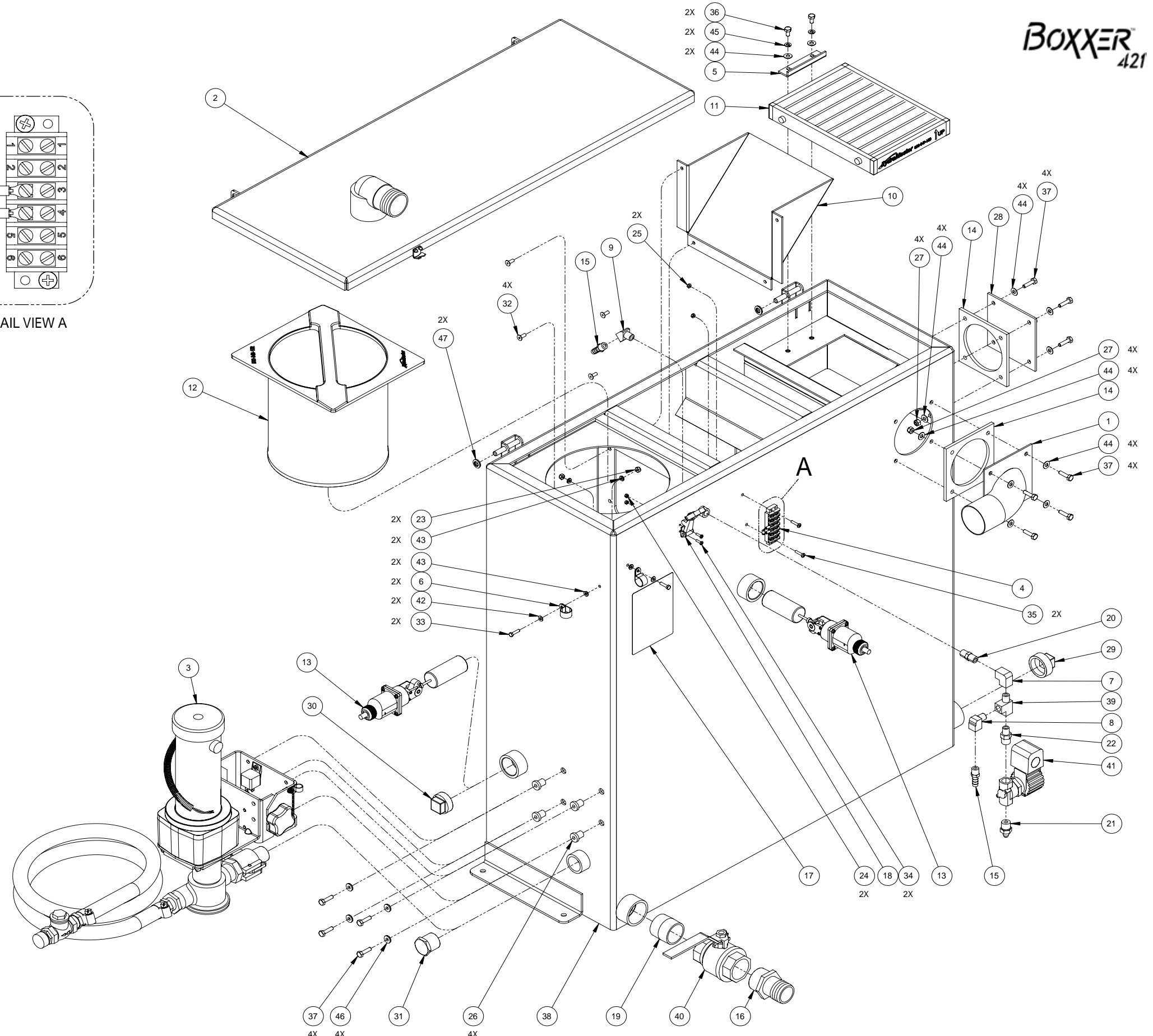
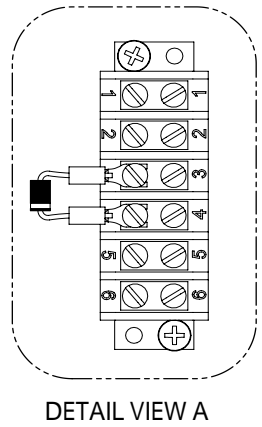


**Figure 9-25. Briggs and Stratton Voltage Regulator Modification**  
3475



Item	Part Number	Description	Qty
1	---	Briggs and Stratton Voltage Regulator	1
2	000-178-026	Wire, 16 AWG Yellow	2
3	000-037-033	Butt Connector, #22 Pink	4

**Figure 9-26. 70 Gallon Universal  
Recovery Tank Assembly**  
610-003-720 Rev. B

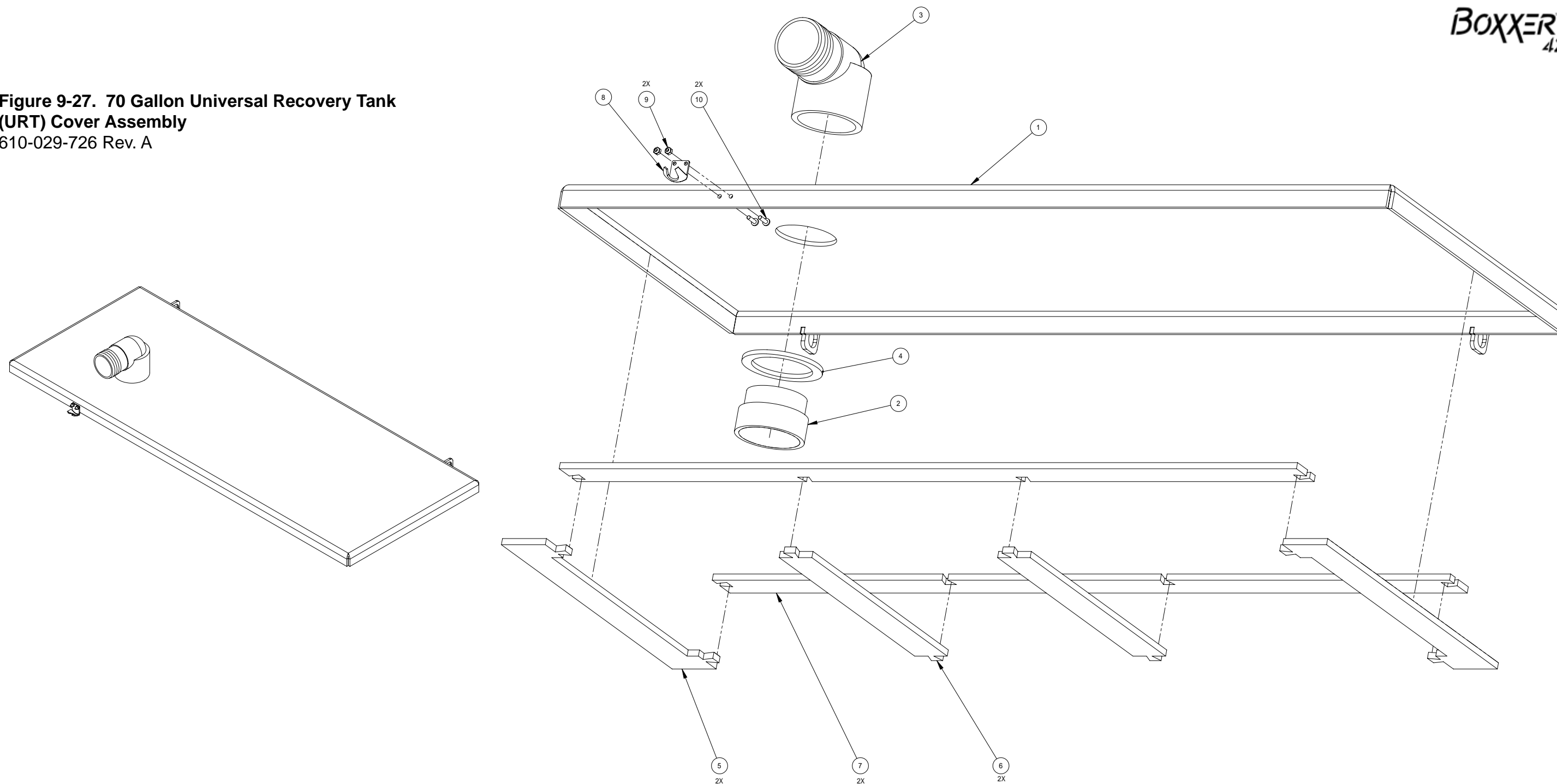


### 70 Gallon Universal Recovery Tank Assembly Parts List

Item	Part Number	Description	Qty	Item	Part Number	Description	Qty
1	000-001-134	Adapter, Ø2.5" Tank X 90° Blower Hose - Coated	1	25	000-094-059	Nut, #8-32UNC Nylock	2
2	610-029-726	Assembly, Cover, 70 Gal URT, Single Vac. - Coated	1	26	000-094-113	Nut, 1/4"-20UNC Neoprene Wellnut	4
3	000-079-091	Assembly, Dura-Flow APO - Production	1	27	000-094-009	Nut, 1/4"-20UNC Nylock	8
4	000-012-002	Block, 6 Post Terminal	1	28	000-105-336	Plate, Vacuum Port Cover - Coated	1
5	000-015-932	Bracket, Flat Filter Securing - Uncoated	1	29	000-106-019	Plug, 1-1/2" NPT	1
6	000-033-023	Clamp, 3/4" Nylon Hose	2	30	000-106-046	Plug, 1-1/4" NPT	1
7	000-052-088	Elbow, 1/4" FPT X FPT	1	31	000-106-049	Plug, 1" NPT Black Nylon	1
8	000-052-085	Elbow, 1/4" NPT Street	1	32	000-140-023	Rivet, AB8-6A Aluminum Pop	4
9	000-052-082	Elbow, 1/4" NPT Street X 45°	1	33	000-143-132	Screw, #10-24UNC X 0.75" Lg. Hex Head	2
10	000-049-154	Filter, Air Deflector, URT - Fabricated	1	34	000-143-539	Screw, #6-32UNC X 0.50" Lg. Button Head	2
11	000-049-153	Filter, Flat - Universal Recovery Tank	1	35	000-143-051	Screw, #8-32UNC X 3/4" Lg. Binder Head	2
12	000-049-152	Filter, Recovery Tank Basket	1	36	000-143-333	Screw, 1/4"-20UNC X 0.50" Lg. Hex Head	2
13	000-157-091	Float, Lever Switch	2	37	000-143-002	Screw, 1/4"-20UNC X 1.00" Lg. Hex Head	12
14	000-057-206	Gasket, Adapter - URT	2	38	000-159-128	Tank, 70 Gallon URT - Coated	1
15	000-052-102	Insert, #46 (1/4" NPT X 3/8" Barb)	2	39	000-052-090	Tee, 1/4" NPT Branch M-F-F	1
16	000-052-226	Insert, 1-1/2" NPT X 1-1/2" Barb (Gray)	1	40	000-169-022	Valve, 1-1/2" Full Port Ball	1
17	000-081-332	Label, Maintenance and Lube Schedule	1	41	000-169-082	Valve, 12 Volt Solenoid 1,200 psi	1
18	000-086-008	Latch, Bungee	1	42	000-174-001	Washer, #10 Flat	2
19	000-052-763	Nipple, 1-1/2" IPS Close S/S	1	43	000-174-036	Washer, #10 Flat Rubber Backed	4
20	000-052-071	Nipple, 1/4" NPT Hex	1	44	000-174-003	Washer, 1/4" Flat	18
21	000-052-662	Nipple, 3/8" NPT X 1/4" M SAE	1	45	000-174-019	Washer, 1/4" Lock	2
22	000-052-073	Nipple, 3/8" NPT X 1/4" NPT Hex	1	46	000-174-060	Washer, 1/4" Rubber Backed	4
23	000-094-034	Nut, #10-24UNC Nylock	2	47	000-174-029	Washer, 3/8" Rubber Backed	2
24	000-094-063	Nut, #6-32UNC Nylock	2				



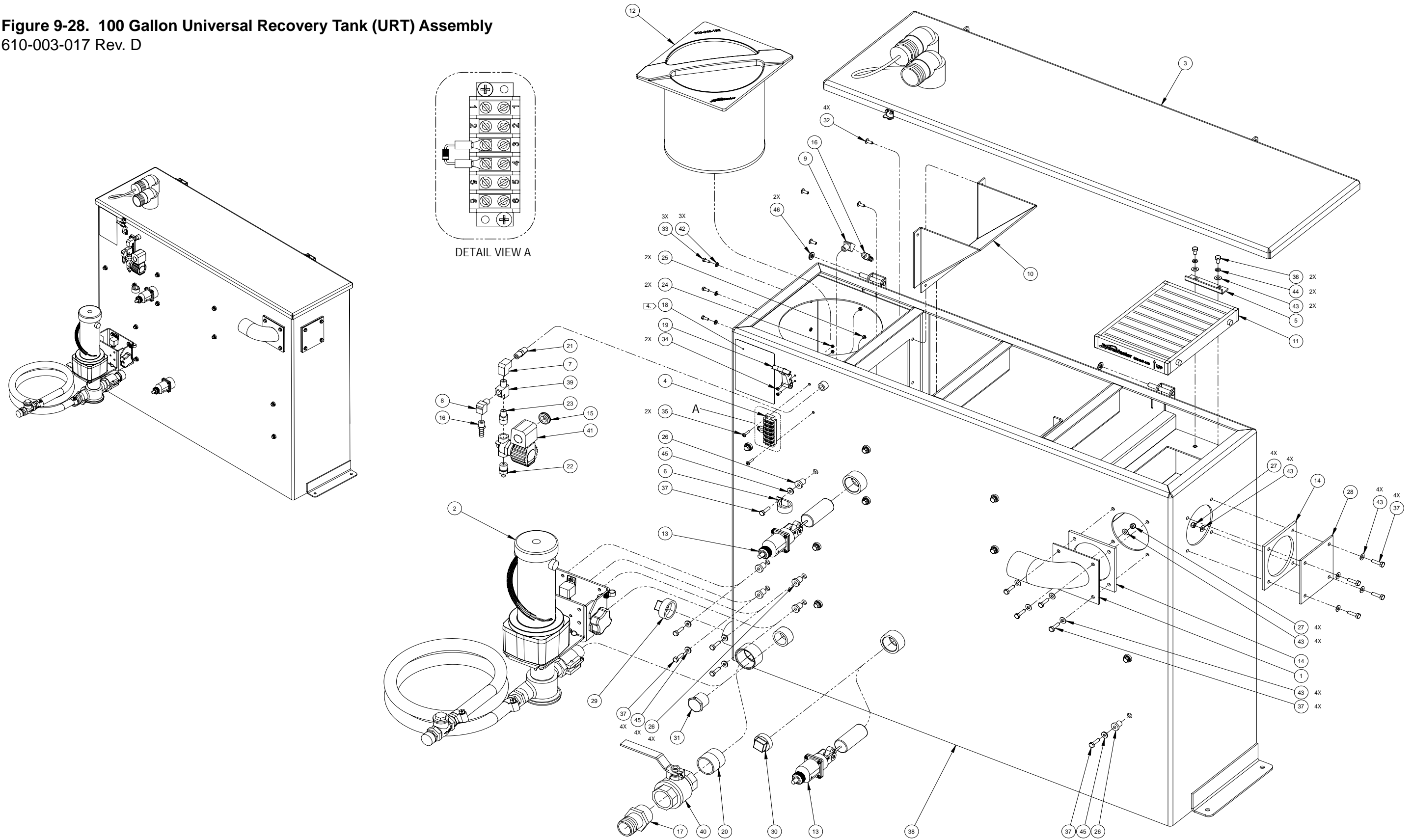
**Figure 9-27. 70 Gallon Universal Recovery Tank (URT) Cover Assembly**  
610-029-726 Rev. A



**70 Gallon Universal Recovery Tank Cover Assembly Parts List**

Item	Part Number	Description	Qty	Item	Part Number	Description	Qty
1	000-041-443	70 Gallon URTCover, Single Vac. - Coated	1	6	000-057-203	Gasket, Middle - Rec. Tank Cover	2
2	000-052-219	Adapter, 2\" NPT X 2\" F Slip	1	7	000-057-204	Gasket, Side - Recovery Tank	2
3	000-052-222	Elbow, 2\" Barb X 2\" FPT	1	8	- - -	Latch, Bungee - Strike (Part of 000-086-008)	1
4	000-057-015	Gasket, 1-1/2\" Bulkhead Fitting	1	9	000-094-063	Nut, #6-32UNC Nylock	2
5	000-057-202	Gasket, End - Rec. Tank Cover	2	10	000-143-539	Screw, #6-32UNC X 0.50\" Lg. Button Head	2

**Figure 9-28. 100 Gallon Universal Recovery Tank (URT) Assembly**  
610-003-017 Rev. D



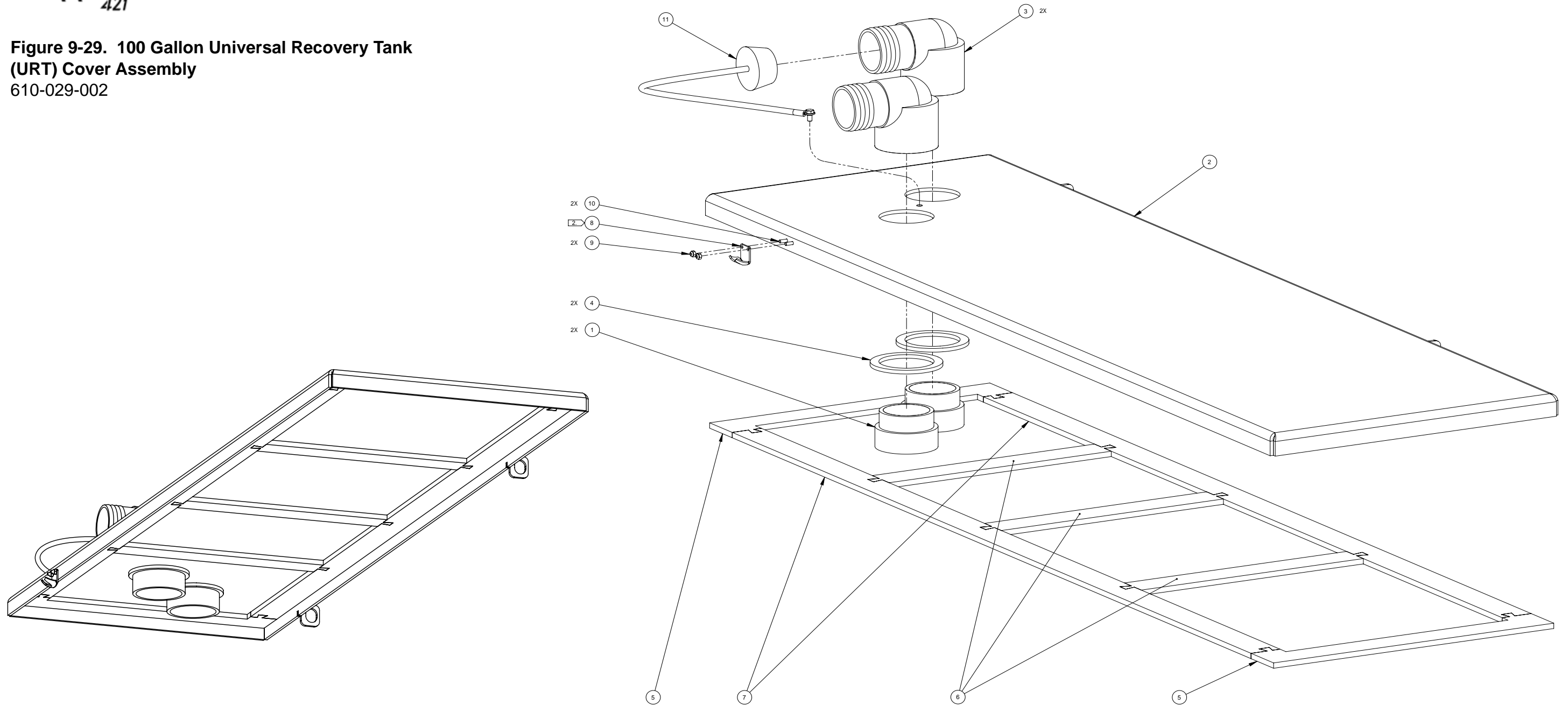


### 100 Gallon Universal Recovery Tank (URT) Assembly Parts List

Item	Part Number	Description	Qty
1	000-001-134	Adapter, Ø2.5" Tank X 90° Blower Hose - Coated	1
2	000-079-091	Assembly, Dura-Flow APO	1
3	610-029-002	Assembly, Recovery Tank Cover	1
4	000-012-002	Block, 6 Post Terminal	1
5	000-015-932	Bracket, Flat Filter Securing - Uncoated	1
6	000-033-057	Clamp, 1" Cushion Loop	1
7	000-052-088	Elbow, 1/4" FPT X FPT	1
8	000-052-085	Elbow, 1/4" NPT Street	1
9	000-052-082	Elbow, 1/4" NPT Street X 45°	1
10	000-049-154	Filter, Air Deflector, URT - Fabricated	1
11	000-049-153	Filter, Flat - URT	1
12	000-049-152	Filter, Recovery Tank Basket	1
13	000-157-091	Float, Lever Switch	2
14	000-057-206	Gasket, Adapter - URT	2
15	000-060-002	Grommet, Large Wiring	1
16	000-052-102	Insert, #46 (1/4" NPT X 3/8" Barb)	2
17	000-052-226	Insert, 1-1/2" NPT X 1-1/2" Barb (Gray)	1
18	000-081-332	Label, Maintenance and Lube Schedule	1
19	000-086-008	Latch, Bungee	1
20	000-052-763	Nipple, 1-1/2" IPS Close S/S	1
21	000-052-071	Nipple, 1/4" NPT Hex	1
22	000-052-662	Nipple, 3/8" NPT X 1/4" M SAE	1
23	000-052-073	Nipple, 3/8" NPT X 1/4" NPT Hex	1

Item	Part Number	Description	Qty
24	000-094-063	Nut, #6-32UNC Nylock	2
25	000-094-059	Nut, #8-32UNC Nylock	2
26	000-094-113	Nut, 1/4"-20UNC Neoprene Wellnut	14
27	000-094-009	Nut, 1/4"-20UNC Nylock	8
28	000-105-336	Plate, Vacuum Port Cover - Coated	1
29	000-106-019	Plug, 1-1/2" NPT	1
30	000-106-046	Plug, 1-1/4" NPT	1
31	000-106-049	Plug, 1" NPT Black Nylon	1
32	000-140-023	Rivet, AB8-6A Aluminum Pop	4
33	000-143-126	Screw, #10-24UNC X 0.50" Lg. Hex Head	3
34	000-143-539	Screw, #6-32UNC X 0.50" Lg. Button Head	2
35	000-143-051	Screw, #8-32UNC X 3/4" Lg. Binder Head	2
36	000-143-333	Screw, 1/4"-20UNC X 0.50" Lg. Hex Head	2
37	000-143-002	Screw, 1/4"-20UNC X 1.00" Lg. Hex Head	22
38	000-159-129	Tank, 100 Gal. Universal Recovery - Coated	1
39	000-052-090	Tee, 1/4" NPT Branch M-F-F	1
40	000-169-022	Valve, 1-1/2" Full Port Ball	1
41	000-169-082	Valve, 12 Volt Solenoid 1,200 psi	1
42	000-174-036	Washer, #10 Flat Rubber Backed	3
43	000-174-003	Washer, 1/4" Flat	18
44	000-174-019	Washer, 1/4" Lock	2
45	000-174-060	Washer, 1/4" Rubber Backed	14
46	000-174-029	Washer, 3/8" Rubber Backed	2

**Figure 9-29. 100 Gallon Universal Recovery Tank (URT) Cover Assembly**  
610-029-002

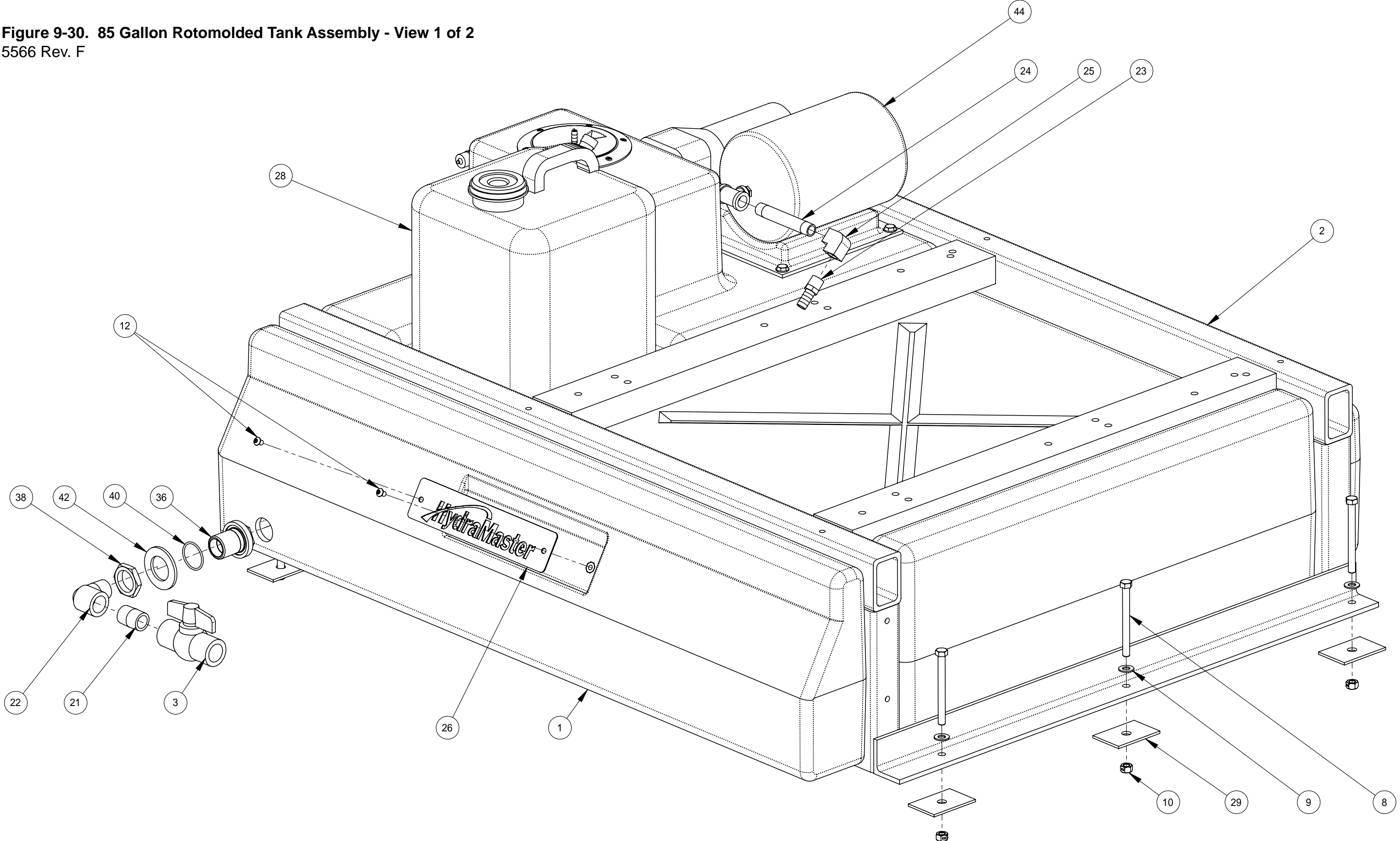


**100 Gallon Universal Recovery Tank (URT) Cover Assembly Parts List**

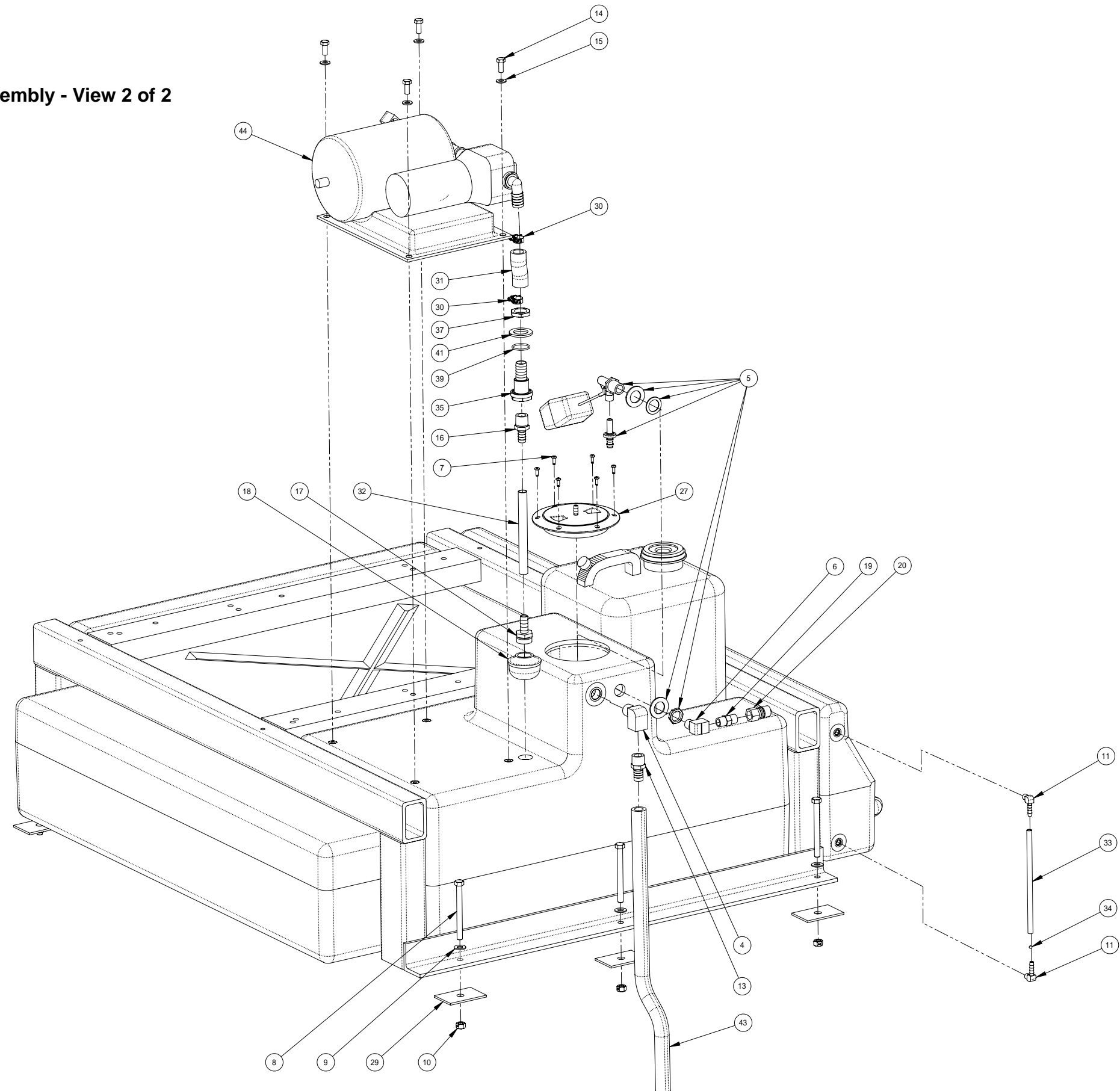
Item	Part Number	Description	Qty
1	000-052-219	Adapter, 2" NPT X 2" F Slip	2
2	000-041-447	Cover, 100 Gal. Universal Recovery Tank - Coated	1
3	000-052-222	Elbow, 2" Barb X 2" FPT	2
4	000-057-015	Gasket, 1-1/2" Bulkhead Fitting	2
5	000-057-202	Gasket, End - Rec. Tank Cover	2
6	000-057-203	Gasket, Middle - Rec. Tank Cover	3

Item	Part Number	Description	Qty
7	000-057-205	Gasket, Side - Rec. Tank Cover	2
8	000-086-008	Latch, Bungee - Strike (Part of 000-086-008)	1
9	000-094-063	Nut, #6-32UNC Nylock	2
10	000-143-539	Screw, #6-32UNC X 0.50" Lg. Button Head	2
11	000-078-039	Vacuum Inlet Stopper	1

Figure 9-30. 85 Gallon Rotomolded Tank Assembly - View 1 of 2  
5566 Rev. F



**Figure 9-31. 85 Gallon Rotomolded Tank Assembly - View 2 of 2**  
5566 Rev. F



### 85 Gallon Rotomolded Tank Assembly Parts List

Item	Part Number	Description	Qty
1	000-159-116	Tank, 85 Gallon Rotomolded Fresh Water	1
2	000-055-169	Frame, Rotomolded Fresh Water Tank	1
3	000-169-202	Valve, 3/4" FPT Ball Valve	1
4	000-052-087	Elbow, 1/2" NPT Street	1
5	000-169-218	Valve, Float, Water Box	1
6	000-052-086	Elbow, 3/8" NPT Street	1
7	000-143-314	Screw, #8 X 1/2" Lg. Pan Head	6
8	000-143-198	Screw, 3/8"-16UNC X 4" Lg. Hex Head - Full Thread	6
9	000-174-005	Washer, 3/8" Flat	6
10	000-094-015	Nut, 3/8"-16UNC Hex 2-Way Locking	6
11	000-052-253	Elbow, 1/8" NPT X 1/4" Barb	2
12	000-143-565	Screw, 1/4"20UNC X 0.375" Lg. Button Head Socket	2
13	000-052-130	Insert, #810 (1/2" NPT X 5/8" Barb)	1
14	000-143-012	Screw, 5/16"-18UNC X 3/4" Lg.	4
15	000-174-049	Washer, 5/16" Flat	4
16	000-052-107	Insert, #88 (1/2" NPT X 1/2" Barb)	1
17	000-052-160	Insert, 3/4" M Garden X 1/2" Barb	1
18	000-049-020	Filter Screen - Medium	1
19	000-052-074	Nipple, 3/8" NPT Hex	1
20	000-052-052	Quick Connect, 660 3/8" Brass w/ EPDM O-Ring	1
21	000-052-326	Nipple, 3/4" NPT Close	1
22	000-052-726	Elbow, 3/4" Street (Gray)	1

Item	Part Number	Description	Qty
23	000-052-105	Insert, #68 (3/8" NPT X 1/2" Barb)	1
24	000-052-408	Nipple, 3/8" NPT X 4" Lg.	1
25	000-052-142	Elbow, 3/8" F X F Brass	1
26	000-105-313	Plate, HydraMaster Name - Roto Tank	1
27	000-041-004	Cover, Poly Water Box Mod., w/Vent	1
28	000-159-016	Jug, 5 Gallon Plastic Chemical - Standard	1
29	600-011-003	Tie Down Cleat, Washer	6
30	000-068-069	Hose, 3/4" I.D. Weatherhead Blue	1
31	000-068-018	Hose, 1/2" I.D.	1
32	000-068-025	Hose, 1/4" I.D. Clear	1
33	000-005-008	Sight Float Bead, 5mm Red Wally Whale	1
34	000-052-785	Head, 1/2" FPT X 3/4" Barb	1
35	000-052-786	Head, 3/4" FPT	1
36	000-094-097	Nut, 1"-14UNS Brass	1
37	000-094-121	Nut, 1-5/16"-12UN Brass	1
38	000-097-072	O-Ring, 1.06" I.D. X 3/32" Width	1
39	000-097-073	O-Ring, 1.375 I.D. X 3/32" Width	1
40	000-174-173	Washer, 1" I.D. X 1.60 O.D. X 0.135" Thk.	1
41	000-174-174	Washer, 1.375" I.D.	1
42	000-068-020	Hose, .625" I.D. - Green Stripe	1
43	000-111-170	Pump, Flojet w/ Bladder 40 psi Fresh Water	1
44	000-033-029	Clamp, Size #12 Hose	2



**Hose Routings**

Hose Part No.	Hose Description	From	To	Length
000-068-018	1/2" Rubber	By-Pass Valve (000-169-081)	Poly Water Box Tank (000-159-105)	48"
000-068-030	5/32" Vac.	0 - 30" Hg Vac. Gauge (000-074-017)	Blower Collector Box (000-013-051)	34"
		Engine Intake	Diverter Check Valve (000-169-156)	48"
		Diverter Check Valve (000-169-156)	3/16" Plastic Vac Tee (000-052-155)	24"
		Gravity Feed Oil Cup (000-052-272)	Blower Collector Box (000-013-051)	50"
		Blower Collector Box (000-013-051)	Diverter Check Valve (000-169-156)	9"
		Diverter Check Valve (000-169-156)	3/16" Plastic Vac Tee (000-052-155)	1 1/2"
		3/16" Plastic Vac Tee (000-052-155)	3/16" Plastic Vac Tee 000-(052-155)	1 3/4"
		3/16" Plastic Vac Tee (000-052-155)	Upper Primary Vac. Solenoid Valve (000-169-070)	24"
		3/16" Plastic Vac Tee (000-052-155)	Upper Primary Vac. Solenoid Valve (000-169-070)	52"
		Upper Primary Vac. Solenoid Valve (000-169-070)	Air Cylinder Valve (000-169-169)	16"
Upper Primary Vac. Solenoid Valve (000-169-070)	Air Cylinder Valve (000-169-169)	8"		
000-068-085	3/8" Hi Temp	12v Solenoid (000-169-082) on Recovery Tank	180°F Valve (000-169-011)	5 ft
		Chemical Pump (000-111-035)	Chemical Meter. Valve (000-160-160)	2.5 ft
000-068-086	2" Rubber	3/8" Dump Valve (000-169-064)	By-Pass Valve (000-169-081)	18"
000-068-219	1/2" w/Inserts and Cap.	Engine Oil Drain Hose, Pump Oil Drain Hose, 2x Blower Oil Drain Hose		24"
000-068-103	1/2" Blue	Hard Water MagnaClean (000-163-056)	Poly Water Box (000-159-105)	58"
000-068-326	3/8" Clear w/Braid	Chemical Jug Pick-up	Chemical Meter. Valve (000-169-160)	5 ft
		Chemical Jug Return	3-way Chemical Valve (000-169-0171)	5 ft
000-068-398	3" ID x 3 ply Silicone x 36" Lg.	Blower Heat Ex. (000-038-053)	Silencer (000-093-080)	6"
		Exhaust Turn Down Adapter (000-011-098)	Blower Heat Exchanger (000-038-053)	1/4"
000-068-588	Throb	HydraPump (000-111-042)	By-Pass Valve (000-169-081)	50 1/2"
000-068-641	3/8" Teflon w/JIC ends	By-Pass Valve (000-169-081)	Blower Heat Exchanger (000-038-053)	10"
000-068-643	3/8" Teflon w/JIC ends	Hi PSI Manifold (000-090-010)	Hi PSI manifold (OUT) (000-090-008)	30 1/2"
000-068-644	3/8" Teflon w/JIC ends	After-Burner (000-038-054)	Hi PSI Manifold (000-090-010)	49 1/2"
000-068-645	3/16" Teflon w/ JIC Ends	Pressure Gauge, 0-1,500 p (000-074-007)	3/8" Female Cross (000-052-113), on By-Pass Valve (000-169-081)	19 3/4"
000-068-646	3/16" Teflon w/ JIC Ends	Chemical Pump (000-111-035)	3-Way Chemical Valve (000-169-017)	29 1/4"
000-068-647	3/16" Teflon w/ JIC Ends	Primary Orifice (000-180-004)	Poly Water Box Tank (000-159-105)	47 1/4"
000-068-648	3/16" Teflon w/ JIC Ends	Secondary Orifice (000-180-006)	12V, 1,200 psi Solenoid Valve (000-169-082)	61 1/4"
000-068-649	3/4" Steam Out	HydraPump (000-111-042)	Poly Water Box Tank (000-159-105)	23"
000-068-157	1/4" Fuel	Carburetor	Fuel Pump (000-111-008)	8 ft
000-068-736	3/8" X 19.5"	Blower Heat Ex. (000-038-053)	After-Burner (000-038-054)	19 1/2"

# 10 - How to Order Parts

To order warranty replacement parts or repairs, it is important that you read this section which includes:

- Warranty Parts Orders
- Parts Orders
- Emergencies

## **WARRANTY PARTS ORDERS**

1. Call the local distributor where you purchased your equipment and ask for the Service Department.
2. Have the following information ready:
  - a. Equipment Model
  - b. Date of Purchase
  - c. Unit Serial Number
  - d. Description of Malfunction
3. Once it has been determined which parts are needed to correct the problem with your machine, make arrangements with your distributor to either perform the repairs or ship the parts to you.

Any questions you have regarding the warranty program should be directed to the Customer Service Department at (425) 775-7275, 7 a.m. to 5 p.m. Monday through Friday (PT).

We shall always endeavor to be fair in our evaluation of your warranty claim and shall provide you with a complete analysis of our findings.

HydraMaster warranty covers only defective materials and/or workmanship for the periods listed. Diagnostic reimbursement is specifically excluded.

## **PARTS ORDERS**

Call your local distributor. In most instances, they either stock or have access to parts through a regional service center.

## **EMERGENCIES**

If, for any reason, your distributor is unable to supply you with the necessary parts, they may call us and arrange for expedited shipping.

HydraMaster sells parts only through authorized distributors and service centers.

**BOXXER**<sup>™</sup>  
421



# 11 - Warranty Information

To avoid misunderstandings which might occur between machine owners and manufacturer, we are listing causes of component failure that specifically voids warranty coverage. Such causes as listed in the following shall constitute abuse or neglect.

## **BLOWER**

- Failure to lubricate impellers daily with an oil based lubricant.
- Failure to lubricate bearings as recommended in blower manual.
- Failure to maintain proper oil levels in the blower.
- Failure to use the correct oil grade and viscosity as recommended in blower manual.
- Failure to properly maintain blower safeguard systems such as waste tank filter screen, vacuum safety relief valve and waste tank automatic shut-off system.
- Allowing foam to pass through blower.

## **HIGH PRESSURE WATER PUMP**

- Failure to maintain proper oil level as recommended in pump manual.
- Failure to change oil in pump at recommended intervals.
- Failure to protect pump against freezing.
- Failure to maintain pump protection shut-off system.
- Failure to use water softener in hard water areas.
- Use of improper chemicals.

## **VACUUM RECOVERY TANK**

- Failure to properly maintain filtering devices in tank.
- Failure to clean tank as recommended by manufacturer.
- Failure to maintain vacuum safety release in blower collector box.
- Use of improper chemicals.

## **CHEMICAL SYSTEM**

- Use of improper chemical.
- Failure to use water softener in hard water area.
- Operating machine without proper chemical filter screen.
- Failure to protect against freezing.



## **CONTROL PANEL**

- Failure to protect flowmeter and water pressure gauge against freezing.

## **VACUUM AND SOLUTION HOSES**

- Failure to protect hoses against freezing.
- Failure to protect hoses against burns from engine and blower exhaust.
- Damage to hoses from being run over by vehicles.
- Kinking or cracking from failure to store or unroll hoses correctly.
- Normal wear and tear from everyday use.

## **CLEANING WAND**

- Failure to protect against freezing.
- Obvious physical abuse of wand.

## **WATER HEATING SYSTEM**

- Over-pressurization of the system (recommended maximum working pressure - 1,000 psi).
- Failure to protect against freezing.

## **HARD WATER DEPOSITS**

- Failure to use or maintain a water softening system or a properly installed magnetic-type descaler, whichever might be necessary, with machines operating in designated "Hard Water Areas" (3.0 grains or more per gallon).

## **WARRANTY PROCEDURE**

Warranty coverage is available to you through your local distributor. Please refer to the Golden Guarantee© Limited Warranty document shipped to you with the Owner's Guide. You can also download a copy of the Golden Guarantee at <http://hydramaster.com/KnowledgeCenter/Warranty.aspx>.

If you have moved to a new area or have purchased a used machine and need information regarding your local distributor, call HydraMaster at (425) 775-7272 or email us at: [techsupport@hydramaster.com](mailto:techsupport@hydramaster.com).

When calling your distributor, be sure to have the machine's information; model and serial number, ready for the service representative.

# 12 - Accessories and Chemical Solutions

HydraMaster's machine accessories are the most innovative collection available in the cleaning industry. For example, our RX-20 Rotary Extractors have changed the shape of carpet cleaning. In addition, our hoses, reels and tanks are of the finest quality construction.

Our carpet care and hard floor care chemical solutions have been specially prepared, not only to give you exceptional cleaning, but also to optimize your truckmount's operation and reliability. HydraMaster's chemical solutions will help maintain your machine's water pump and water heating systems at peak efficiency and also help ensure fewer breakdowns.

HydraMaster's full line of machine accessories and chemicals can enhance cleaning performance while reducing your labor costs, and include:

- Upholstery Tools
- Wands
- Vacuum Hoses
- Tanks
- Van Accessories
- Hose Reels
- Carpet Care Detergents
- Rinse Agents
- Pre-Sprays
- Hard Floor Care Detergents
- Defoamers and Descalers
- Deodorizers and Disinfectants
- Spotting Agents

For more information about our full line of accessories and chemical solutions, refer to the HydraMaster website at <http://www.hydramaster.com>.

To order genuine HydraMaster accessories and chemical solutions, call your nearest authorized HydraMaster Distributor.

**BOXXER**<sup>™</sup>  
421